

COMPREHENSIVE GRAMMAR RESOURCES

Henk van Riemsdijk & István Kenesei, series editors

# Syntax of *Dutch*

*Verbs and  
Verb Phrases*

VOLUME 3

Hans Broekhuis  
Norbert Corver



Amsterdam  
University  
Press

Syntax of Dutch  
Verbs and Verb Phrases  
Volume 3

# **Comprehensive Grammar Resources**

Editors:

Henk van Riemsdijk

István Kenesei

**Syntax of Dutch  
Verbs and Verb Phrases  
Volume 3**

Hans Broekhuis  
Norbert Corver

With the cooperation of:  
Hans Bennis  
Frits Beukema  
Crit Cremers  
Henk van Riemsdijk

**Amsterdam University Press**

The publication of this book is made possible by grants and financial support from:  
Netherlands Organisation for Scientific Research (NWO)  
Center for Language Studies  
University of Tilburg  
Truus und Gerrit van Riemsdijk-Stiftung  
Meertens Institute (KNAW)

This book is published in print and online through the online OAPEN library  
([www.oapen.org](http://www.oapen.org)).

Cover design: Studio Jan de Boer, Amsterdam  
Layout: Hans Broekhuis

ISBN 978 90 8964 732 0  
e-ISBN 978 90 4852 484 6 (pdf)  
NUR 616 / 624



Creative Commons License CC BY NC  
(<http://creativecommons.org/licenses/by-nc/3.0>)

© Hans Broekhuis/Amsterdam University Press, Amsterdam 2016

Some rights reserved. Without limiting the rights under copyright reserved above, any part of this book may be reproduced, stored in or introduced into a retrieval system, or transmitted, in any form or by any means (electronic, mechanical, photocopying, recording or otherwise).

# Contents

## Volume 1

<b>Abbreviations and symbols</b>	<b>v</b>
<b>Preface and acknowledgments</b>	<b>vii</b>
1. General introduction	vii
2. Main objective	vii
3. Intended readership	vii
4. Object of description	viii
5. Organization of the material	xiii
6. History of the project and future prospects	xvii
7. Acknowledgments	xix
<b>Introduction</b>	<b>1</b>
<b>Chapter 1</b>	
<b>Characterization and classification</b>	<b>13</b>
Introduction	14
1.1. General characterization	14
1.2. Verb classifications	19
1.3. Inflection	62
1.4. Mood	79
1.5. Tense, epistemic modality and aspect	102
<b>Chapter 2</b>	
<b>Projection of verb phrases I: Argument structure</b>	<b>181</b>
Introduction	182
2.1. Nominal arguments	185
2.2. Complementives (secondary predicates)	239
2.3. PP-complements (prepositional objects)	284
2.4. AP-complements	329
2.5. Special verbs	332
2.6. Bibliographical notes	397
<b>Chapter 3</b>	
<b>Projection of verb phrases II: Verb frame alternations</b>	<b>401</b>
Introduction	402
3.1. Main types	402
3.2. Alternations involving the external argument	407
3.3. Alternations of noun phrases and PPs	514
3.4. Some apparent cases of verb frame alternation	591
3.5. Bibliographical notes	595

## Volume 2

### Chapter 4

#### **Projection of verb phrases IIIa: Selection of clauses/verb phrases** 597

Introduction	598
4.1. Semantic types of finite argument clauses	601
4.2. Finite and infinitival argument clauses	604
4.3. Control properties of verbs selecting an infinitival clause	608
4.4. Three main types of infinitival argument clauses	610
4.5. Non-main verbs	624
4.6. The distinction between main and non-main verbs	630

### Chapter 5

#### **Projection of verb phrases IIIb: Argument and complementive clauses** 639

Introduction	640
5.1. Finite argument clauses	641
5.2. Infinitival argument clauses	765
5.3. Complementive clauses	936

### Chapter 6

#### **Projection of verb phrases IIIc: Complements of non-main verbs** 945

Introduction	946
6.1. Characteristics and typology of non-main verbs	946
6.2. Non-main verbs selecting a participle	951
6.3. Non-main verbs selecting a <i>te</i> -infinitive	1003
6.4. Non-main verbs selecting a bare infinitive	1019

### Chapter 7

#### **Projection of verb phrases IIId: Verb clusters** 1049

Introduction	1050
7.1. Recognizing verb clusters	1051
7.2. The hierarchical order of verbs in verb clusters	1062
7.3. The linear order of verbs in verb clusters	1091
7.4. Permeation of verb clusters	1112
7.5. Bibliographical notes	1117

## Volume 3

### Chapter 8

#### **Projection of verb phrases IV: Adverbial modification** 1119

Introduction	1120
8.1. VP adverbials versus clause adverbials	1120
8.2. Semantic types of adverbial modifiers	1126
8.3. Categorial types of adverbial modifiers	1168
8.4. The unmarked order of adverbial modifiers	1185
8.5. Obligatory adverbial phrases	1200
8.6. Bibliographical notes	1201

### Chapter 9

#### **Word order in the clause I: General introduction** 1203

Introduction	1204
9.1. The overall organization of the clause	1205
9.2. The position of the verbs	1208
9.3. The clause-initial position	1215
9.4. The postverbal field	1221
9.5. The middle field	1230
9.6. Conclusion	1241

### Chapter 10

#### **Word order in the clause II: Position of the finite verb (verb-first/second)** 1243

Introduction	1244
10.1. Placement of the finite verb	1245
10.2. Verbal (X+V) collocations and verb-first/second	1253
10.3. Verb-first/second: special cases	1290

### Chapter 11

#### **Word order in the clause III: Clause-initial position (*wh*-movement)** 1315

Introduction	1316
11.1. The formation of V1- and V2-clauses	1317
11.2. Clause-initial position remains (phonetically) empty	1326
11.3. Clause-initial position is filled	1347

### Chapter 12

#### **Word order in the clause IV: Postverbal field (extraposition)** 1541

Introduction	1542
12.1. General introduction	1543
12.2. Arguments, complementives and selected measure phrases	1550
12.3. Modifiers of the clause	1561
12.4. Parts of constituents	1570
12.5. Word order	1587
12.6. Bibliographical notes	1593



<b>Chapter 13</b>	
<b>Word order in the clause V: Middle field (scrambling)</b>	<b>1595</b>
Introduction	1596
13.1. Unmarked word orders in the middle field of the clause	1599
13.2. A-Scrambling: nominal argument shift	1608
13.3. A'-scrambling: negation, focus and topic movement	1625
13.4. Weak proform shift	1661
13.5. Bibliographical notes	1677
<b>Chapter 14</b>	
<b>Main-clause external elements</b>	<b>1679</b>
Introduction	1680
14.1. Pragmatic markers	1682
14.2. Left dislocation	1691
14.3. Right dislocation	1714
14.4. Bibliographical notes	1733
<b>Glossary (all <i>Syntax of Dutch</i> volumes)</b>	<b>1735</b>
<b>Index (verbs and verb phrases 1-3)</b>	<b>1781</b>
<b>References (verbs and verb phrases 1-3)</b>	<b>1809</b>

## Abbreviations and symbols

This appendix contains a list of abbreviations and symbols that are used in this volume. Sometimes, conventions are adopted that differ from the ones given in this list, but if this is the case this is always explicitly mentioned in the text.

### References to the other volumes of the *Syntax of Dutch*.

References to the chapters and sections to the other volume in the series *Syntax of Dutch* are preceded by a letter: N + section # refers to the two volumes on nouns and noun phrases, A + section # refers to the volume on *Adjectives and adjective Phrases*, and P+section # refers to the volume on *Adpositions and adpositional phrases*. For example, refers to Section P3.2. in Hans Broekhuis (2013). *Syntax of Dutch: Adpositions and adpositional phrases*. Amsterdam: AUP.

### Symbols and abbreviation used in the main text

°xxx	refers to the xxx glossary
Domain D	The activated discourse domain

### Abbreviations used in both the main text and the examples

A-position	Argument position: position accessible to arguments only
A'-position	Non-argument position: position also accessible to non-arguments
AP	Adjectival Phrase
CP	Complementizer Phrase
DP	Determiner phrase
NP	Noun Phrase
Noun phrase	used when the NP-DP distinction is not relevant
NumP	Numeral Phrase
PP	Prepositional Phrase
PO-verb	Verb with a prepositional object
QP	Quantifier Phrase
TP	Tense Phrase
VP	Verb Phrase
Aux <sub>2</sub> -Main <sub>1</sub>	Verb cluster. The numeral indices indicate the hierarchical order of the verbs: V <sub>n+m</sub> is superior to V <sub>n</sub> . the en-dash indicates linear order: the element to the left precedes the element to the right in the surface order of the sentence: see Chapter V7 for details.

### Symbols, Abbreviations and conventions used in the examples

<i>e</i>	Phonetically empty element
Ref	Referent argument (external °thematic role of nouns/adjectives)
Rel	Related argument (internal thematic role of relational nouns)
OP	Empty operator
PG	Parasitic gap
PRO	Implied subject in, e.g., infinitival clauses
PRO <sub>arb</sub>	Implied subject PRO with arbitrary (generic) reference
<i>t</i>	Trace (the original position of a moved element)
xxx	Small caps indicates that xxx is assigned contrastive accent

### Abbreviations used as subscripts in the examples

1p/2p/3p	1 <sup>st</sup> , 2 <sup>nd</sup> , 3 <sup>rd</sup> person	nom	Nominative
acc	Accusative	pl	Plural
dat	Dative	poss	Possessor
ben	Beneficiary	pred	Predicate
dim	Diminutive	rec	Recipient
fem	Feminine	ref	Referent
masc	Masculine	sg	Singular

### Abbreviations used in the glosses of the examples

AFF	Affirmative marker
COMP	Complementizer: <i>dat</i> ‘that’ in finite declarative clauses, <i>of</i> ‘whether/if’ in finite interrogative clauses, and <i>om</i> in infinitival clauses
prt.	Particle that combines with a particle verb
PRT	Particle of different kinds
REFL	The short form of the reflexive pronoun, e.g., <i>zich</i> .
XXX	Small caps in other cases indicates that XXX cannot be translated

### Diacritics used for indicating acceptability judgments

*	Unacceptable
*?	Relatively acceptable compared to *
??	Intermediate or unclear status
?	Marked: not completely acceptable or disfavored form
(?)	Slightly marked, but probably acceptable
no marking	Fully acceptable
%	Varying judgments among speakers
#	Unacceptable under intended reading
\$	Special status: old-fashioned, archaic, very formal, semantically incoherent, degraded/unacceptable for non-syntactic reasons, etc. The nature of the deviation is normally explained in the main text.

### Other conventions

xx/yy	Acceptable both with xx and with yy
*xx/yy	Unacceptable with xx, but acceptable with yy
xx/*yy	Acceptable with xx, but unacceptable with yy
(xx)	Acceptable both with and without xx
*(xx)	Acceptable with, but unacceptable without xx
(*xx)	Acceptable without, but unacceptable with xx
.. <xx>	Alternative placement of xx in an example
.. <*xx> ..	Impossible placement of xx in an example
P ⇒ Q	P necessarily implies Q (material implication)
P ⇏ Q	P does not necessarily imply Q
P ⇔ Q	P necessarily implies Q and vice versa (equivalence)
<i>XX ... YY</i>	Italics indicate binding
XX <sub>i</sub> ... YY <sub>i</sub>	Coindexing indicates coreference
XX <sub>i</sub> ... YY <sub>j</sub>	Counter-indexing indicates disjoint reference
XX <sub>*i</sub> <sub>j</sub>	Unacceptable with index <i>i</i> , acceptable with index <i>j</i>
XX <sub>i</sub> <sub>*j</sub>	Unacceptable with index <i>j</i> , acceptable with index <i>i</i>
[XP ... ]	Constituent brackets of a constituent XP

# Chapter 8 Projection of verb phrases IV: Adverbial modification

<b>Introduction</b>	<b>1120</b>
<b>8.1. VP adverbials versus clause adverbials</b>	<b>1120</b>
<b>8.2. Semantic types of adverbial modifiers</b>	<b>1126</b>
8.2.1. <i>VP adverbials</i>	1127
8.2.2. <i>Clause adverbials</i>	1139
8.2.3. <i>Multiple temporal/locational adverbials</i>	1156
<b>8.3. Categorial types of adverbial modifiers</b>	<b>1168</b>
8.3.1. <i>On the notion of adverb</i>	1169
8.3.2. <i>VP adverbials</i>	1170
8.3.3. <i>Clause adverbials</i>	1181
<b>8.4. The unmarked order of adverbial modifiers</b>	<b>1185</b>
<b>8.5. Obligatory adverbial phrases</b>	<b>1200</b>
<b>8.6. Bibliographical notes</b>	<b>1201</b>

**Introduction**

This chapter discusses adverbial modification of the clause. Section 8.1 starts by introducing the two main classes of adverbials, the so-called VP and clause adverbials: we will discuss their semantic contribution and propose several tests for distinguishing the two kinds. Section 8.2 continues by providing a further semantic subdivision of the main types of adverbial phrases, and Section 8.3 discusses the form of these adverbial phrases and shows that, across-the-board, VP adverbials show a greater variety here than clause adverbials. It seems generally accepted that VP adverbials must follow the clause adverbials; we will show in Section 8.4, however, that the various subtypes of adverbial phrases are subject to additional word order restrictions. Section 8.5 concludes with a brief discussion of verbs such as *wonen* ‘to live’, which obligatorily combine with an adverbial phrase: we will argue that this is not motivated by syntactic but by pragmatic considerations.

**8.1. VP adverbials versus clause adverbials**

Since Jackendoff (1972) a distinction has normally been made between two main classes of adverbials. The first class is the set of VP ADVERBIALS (also called predicate adverbials), which function semantically as modifiers restricting the denotation of the predicate expressed by the verb phrase: prototypical examples are manner adverbs such as *hard* ‘loudly’ in (1a). The second class is the set of CLAUSE ADVERBIALS, also known as sentence adverbials, which may perform a variety of other functions: prototypical examples are modal adverbs such as *waarschijnlijk* ‘probably’ and the negative adverb *niet* ‘not’ in (1b), which can be seen as logical operators taking scope over a proposition. The logical formulas in the primed examples are added to illustrate this semantic difference.

- |     |   |  |
|-----|---|--|
| (1) | • VP adverbial  | • Clause adverbial   |
| a.  | Jan lacht hard.<br>Jan laughs loudly<br>‘Jan is laughing loudly.’ | b. Jan komt waarschijnlijk/niet.<br>Jan comes probably/not<br>‘Jan will probably come/Jan won’t come.’ |
| a’. | HARD LACHEN(j)  | b’. ◊KOMEN(j)/¬KOMEN(j)  |

This section will provide a general discussion of the distinction and propose a number of tests that can be used to distinguish the two types.

*I. Domain of modification: lexical versus functional domain*

The introduction to this section above has shown that while VP adverbials modify the predicative part of the clause, clause adverbials minimally modify the propositional part of the clause. Moreover, the labels VP adverbial and clause adverbial correctly suggest that the two types of adverbials apply to different syntactic domains, which we will assume to correspond to the so-called LEXICAL and FUNCTIONAL domain of the clause. We will briefly introduce these notions in this subsection, and refer the reader to Chapter 9 for a more detailed discussion.

The lexical domain of the clause consists of the main verb and its °arguments and (optional) VP modifiers, which together form a proposition. In (2a), for example, the verb *kopen* ‘to buy’ takes a direct object as its internal argument and is

subsequently modified by the manner adverb *snel* ‘quickly’, while the resulting complex predicate is finally predicated of the verb’s external argument *Jan*. The complex phrase thus formed expresses the proposition represented by the logical formula in (2b).

- (2) a. [Jan [snel [het boek kopen]]]  
 Jan quickly the book buy  
 b. BUY QUICKLY (Jan, the book)

As it is not likely that the linking of semantic and syntactic structure varies arbitrarily across languages, it is often assumed that the hierarchical structure of the lexical domain is more or less invariant across languages, and that the surface differences in word order between languages are superficial phenomena due to, e.g., differences in linearization or movement. Adopting a movement approach, we may assume that the lexical domain is hierarchically structured as in (3), where *NP* and *Clause* stand for the internal theme argument of the verb: we can then account for the word order difference between VO-languages such as English and OV-languages such as Dutch by assuming that the former but not the latter has obligatory V-to-*v* movement; see Section 9.4, sub IC, for more detailed discussion.

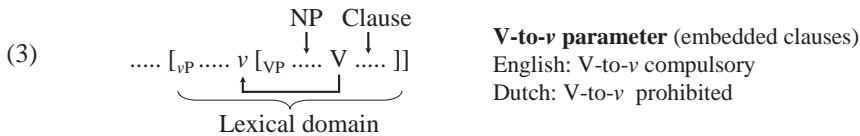

The structure in (2a) can now be made more explicit as in (4): internal arguments such as the theme *het boek* ‘the book’ are generated within VP, VP adverbials such as the manner adverb *snel* ‘quickly’ are adjoined to VP, and external arguments such as the agent *Jan* are generated as the specifier of the “light” verb *v*. For concreteness’ sake, we have assumed that the manner adverb is adjoined to the maximal projection VP within the lexical domain; we will return to this assumption shortly.

- (4) 
$$[{}_{vP} \text{ Jan } v [{}_{VP} \text{ snel } [{}_{VP} \text{ het boek kopen}]]]$$
  
 Jan quickly the book buy

Clause adverbials are generated external to the lexical domain, that is, within the functional domain which contains various functional heads that add information to the proposition expressed by the lexical domain (*vP*). For instance, the functional head *T* in (5) adds the tense feature [ $\pm$ PAST] and the functional head *C* indicates illocutionary force (declarative, interrogative, etc.), as is clear from the fact that the complementizers *dat* ‘that’ and *of* ‘if/whether’ introduce embedded declarative and interrogative clauses, respectively. In addition to these functional heads there may be other functional heads, indicated by *X* in (5), which introduce other features.

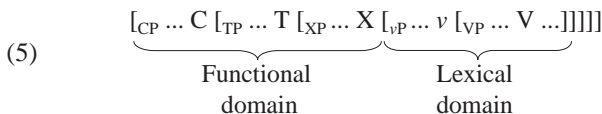

Modal adverbs and negation seem to be located at the boundary between the functional and the lexical domain. On the assumption that adverbial phrases are introduced into the structure by °adjunction to the various maximal projections found in representation (5), we should conclude that they are adjoined to *vP* (or, alternatively, some low functional projection *XP*). This is illustrated in (6b), where we have assumed that the subject is moved from its *vP*-internal position into the regular subject position, the specifier of *TP*. It should be noted, however, that the adjunction analysis is not uncontroversial; Cinque (1999), for example, made a very strong case for assuming that the various subtypes of clause adverbials are generated as specifiers of designated functional heads. If we accept such an approach, the adverb *waarschijnlijk* would be located in the specifier position of a functional head *EM* expressing epistemic modality, as indicated in (6b').

- (6) a. dat Jan waarschijnlijk het boek koopt.  
 that Jan probably the book buys  
 'that Jan will probably buy the book.'  
 b. dat Jan<sub>i</sub> [<sub>VP</sub> waarschijnlijk [<sub>VP</sub> t<sub>i</sub> v [<sub>VP</sub> het boek koopt]]].  
 b'. dat Jan<sub>i</sub> [<sub>EMP</sub> waarschijnlijk EM [<sub>VP</sub> t<sub>i</sub> v [<sub>VP</sub> het boek koopt]]].

Because the choice between the two analyses will not be crucial for the discussion of the Dutch data in this chapter, we refer the reader to Cinque (1999/2003), Ernst (2002), and the references cited there for extensive discussion of the pros and cons of the two approaches. We also refer the reader to Section 13.3.1 on Neg-movement, where we will show that there are strong empirical reasons for adopting Cinque's analysis for the negative adverb *niet* 'not' at least.

## II. Word order

The hypothesis that clause adverbials are external while *VP* adverbials are internal to the lexical domain of the clause correctly predicts that the former precede the latter in the °middle field of the clause; cf. Cinque (1999) and Zwart (2011: section 4.3.2). This generalization is illustrated by the two (b)-examples in (7) for the modal adverb *waarschijnlijk* 'probably' and the manner adverb *hard* 'loudly'.

- (7) a. Relative order of adverbials in the middle field of the clause:  
 clause adverbial > *VP* adverbial  
 b. dat Jan waarschijnlijk hard lacht. [clause adverbial > *VP* adverbial]  
 that Jan probably loudly laughs  
 'that Jan is probably laughing loudly.'  
 b'. \*dat Jan hard waarschijnlijk lacht. [VP adverbial > clause adverbial]  
 that Jan loudly probably laughs

However, the assumptions so far wrongly predict that *VP* adverbials precede the internal arguments of the verb. Example (8a) shows that it is possible for the direct object *de handleiding* 'the manual' to follow the manner adverbial *zorgvuldig* 'meticulously', but example (8b) shows that the object may also precede the adverb. In fact, example (8c) shows that the object may even precede clause adverbials such as *waarschijnlijk* 'probably'. The examples in (8) thus show that there is no strict order between the adverbials and the arguments of the verb in Dutch, a phenomenon that has become known as scrambling. This word order variation is discussed

extensively in Section 13.2, where we will argue that it results from optional leftward movement of the nominal arguments of the verb across the adverbials.

- (8) a. dat Jan waarschijnlijk zorgvuldig de handleiding leest.  
 that Jan probably meticulously the manual reads  
 ‘that Jan is probably reading the manual meticulously.’  
 b. dat Jan waarschijnlijk de handleiding zorgvuldig leest.  
 c. dat Jan de handleiding waarschijnlijk zorgvuldig leest.

Note in passing that there are reasons for assuming that the movement which derives example (8b) is (virtually) obligatory in English, since it accounts for the fact that objects normally precede the manner adverbials in English; see Broekhuis (2008:ch.2) for detailed discussion. An alternative approach to this problem can be found in Ernst (2002:ch.4).

### III. Adverbial tests

A useful test for recognizing VP adverbials is the paraphrase with a conjoined *PRONOUN doet dat* + *ADVERB* ‘PRONOUN does that + ADVERB’ clause; cf. Van den Hoek (1972). This test is schematized in (9a), where the arrow should be read as “can be paraphrased as”: the first conjunct consists of the clause without the VP adverbial, which is used in the second conjunct as a modifier of the phrase *doet dat*, which replaces the verbal projection VP in the first conjunct. The test is applied in (9b) to example (1a).

- (9) • VP-adverbial test I: *PRONOUN doet dat* paraphrase  
 a. [<sub>CLAUSE</sub> subject ... [<sub>VP</sub> ... ADVERBIAL ...]] ⇒  
 [[<sub>CLAUSE</sub> subject<sub>i</sub> ... [<sub>VP</sub> .....]] & [pronoun<sub>i</sub> [doet dat ADVERBIAL]]]  
 b. Jan lacht hard. ⇒ [[Jan lacht] en [hij doet dat hard]].  
 Jan laughs loudly Jan laughs and he does that loudly

The (a)-examples in (10) show that the test does not only work for (in)transitive, but also for unaccusative constructions. The result is sometimes less felicitous in the latter case, but in such cases it is often possible to use an *en dat gebeurde* + *ADVERB* paraphrase instead. This is illustrated in the (b)-examples for the time adverbial *plotseling* ‘suddenly’: the paraphrase in (10b’) contrasts sharply with the paraphrase <sup>??</sup>*De theepot is gebroken, en hij deed dat plotseling*.

- (10) a. Jan/de trein is op tijd vertrokken. ⇒  
 Jan/the train is on time left  
 ‘Jan/the train has left on time.’  
 a’. Jan/de trein is vertrokken en hij deed dat op tijd.  
 Jan/the train is left and he did that on time  
 b. De theepot is plotseling gebroken. ⇒  
 the teapot is suddenly broken  
 ‘The teapot has broken suddenly.’  
 b’. De theepot is gebroken en dat gebeurde plotseling.  
 the teapot is broken and that happened suddenly



Unfortunately, the test cannot be applied to all clauses with a VP adverbial, often for reasons not well understood, but it generally gives reliable results for clauses with an agentive subject and a non-stative/dynamic predicate.

Another test is based on the fact that VP adverbials restrict the denotation of the verbal predicate. As a result of this, the modified predicate will entail the bare predicate, but not vice versa. This is illustrated in (11) for the intransitive verb *lachen* ‘to laugh’ and the unaccusative verb *vertrekken* ‘to leave’. For convenience, we will use the arrow  $\rightarrow$  in the remainder of this chapter to indicate that the entailment is unidirectional.

- (11) • VP-adverbial test II: entailment
- a. Jan lacht hard.  $\rightarrow$  Jan lacht.  
Jan laughs loudly Jan laughs
  - a'. Jan lacht.  $\nrightarrow$  Jan lacht hard.
  - b. De trein vertrekt op tijd.  $\rightarrow$  De trein vertrekt.  
the train leaves on time the train leaves
  - b'. De trein vertrekt.  $\nrightarrow$  De trein vertrekt op tijd.

That clause adverbials like modal adverbs such as *waarschijnlijk* or the negative adverb *niet* do not restrict the denotation of the verbal predicate but perform some other function is clear from the fact that they cannot be paraphrased by means of a conjoined *PRONOUN doet dat* clause, as shown in (12) for the examples in (1b); the arrow with a slash should be read here as “cannot be paraphrased as”.

- (12) a. Jan komt waarschijnlijk.  $\nrightarrow$  [[Jan komt] en [hij doet dat waarschijnlijk]].  
Jan comes probably Jan comes and he does that probably
- b. Jan komt niet.  $\nrightarrow$  [[Jan komt] en [hij doet dat niet]].  
Jan comes not Jan comes and he does that not

The examples in (13) show furthermore that the clause with the clause adverbial does not entail the clause without it, nor vice versa.

- (13) a. Jan komt waarschijnlijk/niet.  $\nrightarrow$  Jan komt.  
Jan comes probably/not Jan comes
- b. Jan komt.  $\nrightarrow$  Jan komt waarschijnlijk/niet.  
Jan comes Jan comes probably/not

Clause adverbials may have several functions: *waarschijnlijk* and *niet*, for instance, can be equated with the logical operators  $\diamond$  and  $\neg$ , which scope over the entire proposition, as in the predicate calculus equivalents of (1b). This is illustrated in (14), where the arrow indicates that the sentence and the logical formula express the same core meaning.

- (14) a. Jan komt waarschijnlijk  $\Leftrightarrow \diamond \text{COME}(j)$   
Jan comes probably
- b. Jan komt niet  $\Leftrightarrow \neg \text{COME}(j)$   
Jan comes not

That clause adverbials are external to the lexical domain of the clause is also made clear by the clause-adverbial test in (15), which shows that clause adverbials can even be external to the entire clause.

- (15) • Clause-adverbial test: scope paraphrase
- a. [<sub>CLAUSE</sub> ... ADVERBIAL [<sub>VP</sub> .....]] ⇒  
 Het is ADVERBIAL ZO [<sub>CLAUSE</sub> dat .... [<sub>VP</sub> .....]]
- b. Jan lacht waarschijnlijk. ⇒ Het is waarschijnlijk zo dat Jan lacht.  
 Jan laughs probably it is probably the.case that Jan works

For the cases in which the VP-adverbial and clause-adverbial tests do not provide satisfactory results, we can appeal to the generalization (7a) from Subsection II that clause adverbials precede VP adverbials in the middle field of the clause: if an adverbial precedes an independently established clause adverbial, it cannot be a VP adverbial; if an adverbial follows a VP adverbial, it cannot be a clause adverbial. For example, all adverbials that precede the modal adverb *waarschijnlijk* can be considered clause adverbials.

The tests discussed above should be approached with caution, due to the fact that specific clause adverbials may sometimes be used with a more restricted scope. A well-known example is the negative adverb *niet* ‘not’, which can be used to express sentence negation, that is, with scope over the complete proposition expressed by the lexical domain of the clause, or as constituent negation, that is, with scope over a smaller constituent within the clause; cf. Section 13.3.2, sub IC. The (a)-examples in (16) show that in the latter case, negation may occur in a conjoined *PRONOUN doet dat*-clause as a modifier of the negated constituent. Whether or not Jan’s advent is indeed entailed by a sentence such as *Jan komt niet volgende WEEK* may be a matter of debate, but it is clear that there is a strong tendency to accept it. The main point is, however, that negation does not function as a VP adverbial in (16a) but as a modifier of the time adverbial; the paraphrase shows that the full constituent *niet volgende week* functions as a VP adverbial. The (b)-examples show that more or less the same observations can be made for modal adverbs such as *waarschijnlijk* ‘probably’; the paraphrase shows that *waarschijnlijk morgen* can function as a complex VP adverbial if *morgen* is assigned contrastive accent.

- (16) a. Jan komt niet volgende WEEK (maar volgende MAAND).  
 Jan probably not next week but next month  
 ‘Jan does not come next WEEK (but next MONTH).’
- a’. Jan komt maar hij doet dat niet volgende WEEK.  
 Jan comes but he does that not next week
- b. Jan komt waarschijnlijk MORGEN.  
 Jan comes probably tomorrow  
 ‘Jan will probably come TOMORROW.’
- b’. Jan komt en hij doet dat waarschijnlijk MORGEN.  
 Jan comes and he does that probably tomorrow

#### IV. Adverbials that can perform multiple syntactic functions

Some adverbials can be used either as a clause adverbial or as a VP adverbial, depending on their position in the middle field of the clause. We illustrate this here by means of temporal adverbials. Consider the punctual adverbial *om drie uur* ‘at 3 o’clock’ in (17a); the fact that the *PRONOUN doet dat* + *ADVERB* paraphrase in (17b)

is possible and the entailment in (17c) is valid shows that we are dealing with a VP adverbial.

- (17) a. Jan vertrekt (waarschijnlijk) om drie uur.  
 Jan leaves probably at 3 o'clock  
 'Jan will (probably) leave at 3 o'clock.'
- b. Jan vertrekt om drie uur. ⇒ [[Jan vertrekt] en [hij doet dat om drie uur]].
- c. Jan vertrekt om drie uur. → Jan vertrekt.

That we are dealing with a VP adverbial in (17a) is also consistent with the fact that it follows the modal adverb *waarschijnlijk* 'probably'. Example (18a) shows, however, that it is not always the case that temporal adverbs must follow the clause adverb. According to the generalization in (7a) that VP adverbials cannot precede clause adverbials, the adverb *morgen* 'tomorrow' must be a clause adverbial, which is confirmed by the fact that the scope paraphrase in (18b) is acceptable.

- (18) a. Jan vertrekt morgen waarschijnlijk.  
 Jan leaves tomorrow probably  
 'Jan will probably leave tomorrow.'
- b. Het is morgen waarschijnlijk zo dat Jan vertrekt.  
 it is tomorrow probably the.case that Jan leaves

The hypothesis that the temporal adverbials in (17a) and (18a) perform different syntactic/semantic functions is supported by the fact illustrated in (19a) that they can co-occur in a single clause. Example (19b) shows that we find similar facts for spatial adverbials.

- (19) a. Jan zal morgen<sub>clause</sub> waarschijnlijk om drie uur<sub>VP</sub> vertrekken  
 Jan will tomorrow probably at three hour leave  
 'Tomorrow, Jan will probably leave at 3 o'clock.'
- b. Jan zal in Amsterdam<sub>clause</sub> waarschijnlijk bij zijn tante<sub>VP</sub> logeren.  
 Jan will in Amsterdam probably with his aunt stay  
 'In Amsterdam, Jan will probably stay at his aunt's place.'

The discussion above shows that we should be aware that adverbials may in principle perform multiple syntactic/semantic functions in a clause, and that we should not jump to conclusions on the basis of the application of a single test.

## 8.2. Semantic types of adverbial modifiers

This section adopts the division between VP and clause adverbials introduced in Section 8.1 as its point of departure. Sections 8.2.1 and 8.2.2 provide a more detailed semantic subdivision of these adverbials and investigate to what extent the various subcategories satisfy the adverbial tests introduced in Section 8.1, sub III. Section 8.2.3 concludes with a more detailed discussion of the spatio-temporal adverbials: Section 8.1 has shown that these adverbials can be used either as VP adverbials or as clause adverbials and we will investigate the differences in semantic contribution of these two uses.

## 8.2.1. VP adverbials

This section discusses various types of VP adverbials. A first group, which will be referred to as process adverbials, consists of adverbials that modify the eventuality itself by indicating, e.g., a manner, an instrument or a means. A second group, which we will refer to as agentive, consists of agentive *door*-PPs, which we find in passive constructions, and comitative *met*-PPs, which introduce a co-agent. A third group consists of spatio-temporal adverbials, which locate the eventuality in space and time. A fourth group consists of contingency adverbials referring to causes, reasons, purposes, etc. We conclude with a brief discussion of predicate-degree adverbials. The adverbials in (20) restrict the denotation of the verbal predicate and are characterized by the fact that they can be questioned by means of a *wh*-phrase.

- (20) • VP adverbials
- a. Process: manner; instrument; means; volition; domain
  - b. Agentive: passive *door*-PP; comitative *met*-PP
  - c. Spatio-temporal: place; time
  - d. Contingency: cause, reason, purpose, result, concession
  - e. Predicate-degree: *erg* ‘very’; *een beetje* ‘a bit’

## 1. Process Adverbials

Process adverbials restrict the denotation of the verbal predicate by adding specific information about the eventuality and are characterized by the fact that they can be questioned by means of a *wh*-phrase. We will briefly discuss the five semantic subclasses in (21).

- (21) • Process adverbials
- a. Manner: *grondig* ‘thoroughly’; *hoe* ‘how’.
  - b. Instrument: *met een schep* ‘with a shovel’; *waarmee* ‘with what’
  - c. Means: *met de bus* ‘by bus’; *hoe* ‘how’
  - d. Domain: *juridisch* ‘legally’; *hoe* ‘how’
  - e. Volition: *vrijwillig* ‘voluntarily’; *graag* ‘gladly’, <sup>?</sup>*hoe* ‘how’

Manner adverbs such as *grondig* ‘thoroughly’ in (22a) are prototypical cases of process adverbials; they restrict the denotation of the verb phrase by specifying the manner in which the eventuality was performed: the primed examples show that manner adverbs satisfy the two VP-adverbial tests introduced in Section 8.1, sub III. Instrumental adverbials such as *met een schep* ‘with a shovel’ in (22b) restrict the denotation of the verb phrase by specifying the instrument used in performing the action; the primed examples show that instrumental adverbials satisfy the two VP-adverbial tests. Instrumentals normally have the form of a *met*-PP although there are also incidental adjectival forms like *handmatig* ‘by hand’ and *machinaal* ‘mechanically’.

- (22) a. Jan heeft het artikel *grondig* gelezen. [manner]  
 Jan has the article thoroughly read  
 ‘Jan has read the article thoroughly.’  
 a’. Jan heeft het artikel gelezen en hij deed dat grondig.  
 a’’. Jan heeft het artikel grondig gelezen. → Jan heeft het artikel gelezen.

- b. Jan heeft het gat *met een schep* gegraven. [instrument]  
 Jan has the hole with a shovel dug  
 'Jan has dug the hole with a shovel.'
- b'. Jan heeft het gat gegraven en hij deed dat met een schep.  
 b''. Jan heeft het gat *met een schep* gegraven. → Jan heeft het gat gegraven.

Another set of process adverbials indicates the means used in performing the action, as in (23a). Substantial subsets of these adverbials indicate means of transportation or communication; some typical examples are given in (23b&c). The primed examples again show that these adverbials satisfy the two VP-adverbial tests.

- (23) a. Jan heeft het gat *met zand* gevuld. [means]  
 Jan has the hole with sand filled  
 'Jan has filled the hole with sand.'
- a'. Jan heeft het gat gevuld en hij deed dat met zand.  
 a''. Jan heeft het gat met zand gevuld. → Jan heeft het gat gevuld.
- b. Jan is *met de bus/te voet* naar Leiden gegaan. [means of transportation]  
 Jan is with the bus/on foot to Leiden gone  
 'Jan has gone to Leiden by bus/on foot.'
- b'. Jan is naar Leiden gegaan en hij deed dat met de bus/te voet.  
 b''. Jan is met de bus/te voet naar Leiden gegaan → Jan is naar Leiden gegaan.
- c. Jan heeft Marie *per brief/telefonisch* ingelicht. [means of communication]  
 Jan has Marie by letter/by.phone informed  
 'Jan has informed Marie by letter/phone.'
- c'. Jan heeft Marie ingelicht en hij deed dat per brief/telefonisch.  
 c''. Jan heeft Marie per brief/telefonisch ingelicht. → Jan heeft Marie ingelicht.

Adverbials like *juridisch* 'legally', *lichamelijk* 'physically', *medisch* 'medically', *psychologisch* 'psychologically', and *wetenschappelijk* 'scientifically' are known as domain adverbials because they restrict the process to a specific (e.g. legal, medical, or scientific) domain.

- (24) a. Jan vecht zijn ontslag *juridisch* aan.  
 Jan fights his dismissal legally prt  
 'Jan contests his dismissal on legal grounds.'
- a'. Jan vecht zijn ontslag aan en hij doet dat *juridisch*.  
 a''. Jan vecht zijn ontslag *juridisch* aan. → Jan vecht zijn ontslag aan.
- b. Marie onderzocht de kat *medisch*.  
 Marie examined the cat medically  
 'Marie medically examined the cat.'
- b'. Marie onderzocht de kat en zij deed dat *medisch*.  
 b''. Marie onderzocht de kat *medisch*. → Marie onderzocht de kat.

Volitional adverbials like *gedwongen* 'forced', *met opzet* 'on purpose', *met tegenzin* 'reluctantly', *met plezier* 'with pleasure', *noodgedwongen* 'by necessity', *opzettelijk* 'deliberately', *per ongeluk* 'by accident', and *vrijwillig* 'voluntarily' specify the relation between the eventuality denoted by the verb (phrase) and the person performing/undergoing it. These adverbials are often considered subject-

oriented, which is well-founded in the case of *vrijwillig* ‘voluntarily’, as passivization of example (25a) shifts the orientation of this adverb from agent to theme.

- (25) a. De dokter onderzocht Marie vrijwillig. [agent]  
 the doctor examined Marie voluntarily  
 ‘The doctor examined Marie of his own volition.’  
 b. Marie werd vrijwillig onderzocht. [theme]  
 Marie was voluntarily examined  
 ‘Marie was examined of her own free will.’

However, adverbials such as *opzettelijk* ‘deliberately’ and *per ongeluk* ‘by accident’ are oriented towards the (implied) agent only, as is clear from the fact that passivization of example (26a) does not affect the orientation of these adverbials.

- (26) a. Jan beledigde Marie opzettelijk. [agent]  
 Jan insulted Marie deliberately  
 b. Marie werd opzettelijk beledigd. [implied agent]  
 Marie was deliberately insulted

The examples in (27) show for the adverbials *vrijwillig* in (25a) and *opzettelijk* in (26a) that volitional adverbials satisfy the two VP-adverbial tests.

- (27) a. De dokter onderzocht Marie en hij deed dat vrijwillig.  
 the doctor examined Marie and he did that voluntarily  
 a’. De dokter onderzocht Marie vrijwillig. → De dokter onderzocht Marie.  
 b. Jan beledigde Marie en hij deed dat opzettelijk.  
 Jan insulted Marie and he did that deliberately  
 b’. Jan beledigde Marie opzettelijk. → Jan beledigde Marie.

That process adverbials are VP adverbials is also supported by the fact that, under a neutral (that is, non-contrastive) intonation, they follow modal adverbials such as *waarschijnlijk* ‘probably’; this is illustrated in (28). We will see in Section 8.2.2, sub XI, however, that domain adverbials such as *juridisch* in (28d) may also be used as clause adverbials.

- (28) a. Jan heeft het gat waarschijnlijk met zand gevuld.  
 Jan has the hole probably with sand filled  
 ‘Jan has probably filled the hole with sand.’  
 b. Jan is waarschijnlijk met de bus/te voet naar Leiden gegaan.  
 Jan is probably with the bus/on foot to Leiden gone  
 ‘Jan has probably gone to Leiden by bus/on foot.’  
 c. Jan heeft Marie waarschijnlijk per brief/telefonisch ingelicht.  
 Jan has Marie probably by letter/by.phone informed  
 ‘Jan has probably informed Marie by letter/phone.’  
 d. Hij vecht zijn ontslag waarschijnlijk juridisch aan.  
 he fights his dismissal probably legally prt  
 ‘He probably contests his dismissal on legal grounds.’  
 e. Jan beledigde Marie waarschijnlijk opzettelijk.  
 Jan insulted Marie probably deliberately  
 ‘Jan probably insulted Marie deliberately.’

*II. Agentive adverbials*

There are two types of agentive adverbials. The agentive *door*-PP in (29a) refers to the agent of the eventuality in passive constructions, while the comitative *met*-PP in (29b) introduces a co-agent. The primed examples show that these adverbials satisfy the first VP-adverbial test, provided we also passivize the conjoined PRONOUN *doet dat* clause in (29a').

- (29) a. Het pakket werd *door Jan* bezorgd. [agentive]  
 the parcel was by Jan delivered  
 'The parcel was delivered by Jan.'
- a'. Het pakket werd bezorgd en dat werd door Jan gedaan.  
 the parcel was delivered and that was by Jan done  
 'The parcel was delivered and that was done by Jan.'
- a''. Het pakket werd *door Jan* bezorgd. → Het pakket werd bezorgd.
- b. Jan heeft *met Els* het museum bezocht. [comitative]  
 Jan has with Els the museum visited  
 'Jan has visited the museum with Els.'
- b'. Jan heeft het museum bezocht en hij deed dat met Els.
- b''. Jan heeft met Els het museum bezocht. → Jan heeft het museum bezocht.

That agentive adverbials are VP adverbials is also supported by the fact illustrated in (30) that, under a neutral intonation, they follow modal adverbials such as *waarschijnlijk* 'probably'. Observe that comitative PPs can easily precede the modal adverbs but only if the nominal complement of *met* can be accented, which suggests that this order is the result of focus movement; cf. Section 13.3.2.

- (30) a. Het pakket wordt waarschijnlijk door Jan bezorgd.  
 the parcel is probably by Jan delivered  
 'The parcel will probably be delivered by Jan.'
- b. Jan heeft <met Els/\*r> waarschijnlijk het museum <met Els/'r> bezocht.  
 Jan has with Els/her probably the museum visited  
 'Jan has probably visited the museum with Els/her.'

*III. Spatio-temporal adverbials*

Spatio-temporal VP adverbials restrict the denotation of the predicate by anchoring the eventuality at a certain location or time.

- (31) a. Marie heeft waarschijnlijk *in de tuin* gewerkt.  
 Marie has probably in the garden worked  
 'Marie has probably been working in the garden.'
- b. Marie heeft waarschijnlijk *om drie uur* koffie gedronken.  
 Marie has probably at 3 o'clock coffee drunk  
 'Marie probably drank coffee at 3 o'clock.'

That the adverbials *in de tuin* and *om drie uur* in (31) function as VP adverbials is not only suggested by the fact that they follow the modal adverb *waarschijnlijk* 'probably' but also by the fact that they satisfy the VP-adverbial tests from Section



8.1, sub III: this is illustrated in (32), which shows that the primeless examples allowing the *PRONOUN* *doet dat* + *ADVERB* paraphrase also pass the entailment test.

- (32) a. Marie heeft *in de tuin* gewerkt.  
 Marie has in the garden worked  
 ‘Marie has been working in the garden.’  
 a’. Marie heeft gewerkt en ze deed dat in de tuin.  
 a’’. Marie heeft in de tuin gewerkt. → Marie heeft gewerkt.  
 b. Marie heeft *om drie uur* koffie gedronken.  
 Marie has at 3 o’clock coffee drunk  
 ‘Marie drank coffee at 3 o’clock.’  
 b’. Marie heeft koffie gedronken en ze deed dat om drie uur.  
 b’’. Marie heeft om drie uur koffie gedronken. → Marie heeft koffie gedronken.

The various subtypes of spatio-temporal VP adverbials will be discussed in Subsections A and B. Note that we diverge from more traditional grammars by assuming that spatial phrases are not only used as adverbials but also as complementives. Semantically, adverbial and complementive phrases differ in that an adverbial phrase provides more information about the eventuality as a whole while a complementive phrase provides more information about the subject or the direct object of the clause (which originates as its °logical SUBJECT). The difference is illustrated in (33): while (33a) expresses that the eventuality of Jan playing takes place in the garden, (33b) merely expresses that Jan’s location is in the garden.

- (33) a. Jan speelt *in de tuin*. [adverbial]  
 Jan plays in the garden  
 ‘Jan is playing in the garden.’  
 b. Jan is *in de tuin*. [complementive]  
 Jan is in the garden

For a more detailed discussion, we refer the reader to Sections P1.1.2.2 and P4.2.1.1, where it is extensively argued that complementive PPs function as predicates denoting a (change of) location or a direction. Some representative examples discussed in these sections are given in (34).

- (34) a. Jan ligt *in het zwembad*. [location]  
 Jan lies in the swimming.pool  
 b. Jan valt *in het zwembad*. [change of location]  
 Jan falls into the swimming.pool  
 c. Jan valt/\*ligt *het zwembad in*. [directional]  
 Jan falls the swimming.pool into

Finally, it should be noted that spatio-temporal adverbials can also be used as clause adverbials; we will ignore this use here and provide the relevant data in Section 8.2.2, sub IX; the semantic difference between the two cases will be investigated in more detail in Section 8.2.3.



A. *Temporal adverbials*

Temporal VP adverbials can be punctual or durational: the adverbial *om drie uur* ‘at 3 o’clock’ in (35a) locates the eventuality of Jan walking in the park at a specific point on the time axis while the adverbial *de hele dag* ‘the whole day’ in (35b) indicates the duration of the eventuality: it refers to an interval on the time axis during which the eventuality of Jan walking in the park took place. The primed examples show that both instances satisfy the VP-adverbial tests.

- (35) a. Jan wandelde *om drie uur* in het park. [punctual]  
 Jan walked at 3 o’clock in the park  
 ‘Jan walked in the park at three o’clock.’  
 a’. Jan wandelde in het park en hij deed dat om drie uur.  
 a’’. Jan wandelde om drie uur in het park. → Jan wandelde in het park.  
 b. Jan wandelde *de hele dag* in het park. [durational]  
 Jan walked the whole day in the park  
 ‘Jan walked in the park all day.’  
 b’. Jan wandelde in het park en hij deed dat de hele dag.  
 b’’. Jan wandelde de hele dag in het park. → Jan wandelde in het park.

In addition, temporal adverbials can be relational or non-relational: cf. Haeseryn et al. (1997). Relational temporal adverbials locate the eventuality expressed by the clause with respect to some other eventuality on the time axis while non-relational temporal adverbials locate the eventuality on the time axis without taking other eventualities into consideration (although the speech time may still function as an anchoring point). Examples of non-relational temporal adverbials are *volgende week* ‘next week’ and *verleden jaar* ‘last year’ in (36). Such adverbials can typically be replaced by the temporal proforms *nu* ‘now’, *toen* ‘then (past)’ and *dan* ‘then (future)’. The adverbials *onlangs* ‘recently’ and *straks* ‘later’ or *spoedig* ‘soon’ are special in indicating proximity to the speech time.

- (36) a. We gaan *volgende week/dan* naar Maastricht.  
 we go next week/then to Maastricht  
 ‘We will go to Maastricht next week/then.’  
 b. Jan is *verleden jaar/toen* gepromoveerd.  
 Jan is last year/then taken.his.PhD  
 ‘Jan was awarded his PhD last year/then.’

Relational temporal adverbials are typically PPs or clauses. Prototypical punctual examples are given in (35a) and in the (a)-examples in (37); in the latter examples, the adverbials locate Jan’s going home in a position after, respectively, the meeting and the moment that Jan had spoken to Els. That the PP and the clause are relational is also clear from the fact that they can be pronominalized by means of the pronominal PP *daarna* ‘after that’ in (37b). It should be noted, however, that they can have a non-relational reading as well, as is clear from the fact that they can also be replaced by the non-relational proform *toen* ‘then’ in (37b’).

- (37) a. Jan ging *na de vergadering* naar huis. [relational/non-relational]  
 Jan went after the meeting to home  
 ‘Jan went home after the meeting.’
- a'. Jan ging naar huis *nadat hij Els gesproken had*. [relational/non-relational]  
 Jan went to home after he Els spoken had  
 ‘Jan went home after he had spoken to Els.’
- b. Jan ging *daarna* naar huis. [relational]  
 Jan went after.that to home
- b'. Jan ging *toen* naar huis. [non-relational]  
 Jan went then to home

In the (a)-examples in (38), we provide instances of a prepositional and a clausal adverbial expressing a durational relation. Although the PP and the clause must receive a relational interpretation, they cannot be replaced by a pronominal PP because PPs headed by *sinds* ‘since’ do not allow pronominalization at all; instead *sindsdien* ‘since then’ in (38b) is used, which is a fossilized form consisting of the preposition *sinds* and a case-marked demonstrative meaning “since that moment”.

- (38) a. Jan heeft *sinds haar vertrek* erg hard gewerkt.  
 Jan has since her departure very hard worked  
 ‘Jan has worked very hard since her departure.’
- a'. Jan heeft erg hard gewerkt *sinds zij vertrokken is*.  
 Jan has very hard worked since she left is  
 ‘Jan has worked very hard since she left.’
- b. Jan heeft *sindsdien* erg hard gewerkt.  
 Jan has since.then very hard worked  
 ‘Jan has worked very hard since then.’

Temporal PPs such as *om drie uur* ‘at 3 o'clock’, *op zondag* ‘on Sunday’, *in (het jaar) 1990* ‘in (the year) 1990’, *op eerste kerstdag* ‘on Christmas Day’, *in/tijdens de vakantie* ‘in/during the vacation’, *tijdens de oorlog* ‘during the war’, which are more or less conventionalized means of referring to specific (often recurring) points/intervals on the time axis, are strictly non-relational: they can only be replaced by a temporal pro-form. Some examples are given in (39).

- (39) a. We gaan *in de vakantie* naar Maastricht.  
 we go in the vacation to Maastricht  
 ‘We are going to Maastricht in the vacation period.’
- a'. We gaan *dan/\*daarin* naar Maastricht.  
 we go then/there.in to Maastricht
- b. Jan is *in 2013* gepromoveerd.  
 Jan is in 2013 taken.his.PhD  
 ‘Jan took his PhD in 2013.’
- b'. Jan is *toen/\*daarin* gepromoveerd.  
 Jan is then/there.in taken.his.PhD

Temporal adverbials may also refer to a repeated action: example (40a) may express the single eventuality of Jan ringing the doorbell three times (e.g. as a

means of identifying himself). That we are dealing with VP adverbials is again clear from the (b)-examples, which show that the two VP-adverbial tests can be satisfied.

- (40) a. Jan belde *drie keer (achter elkaar)* aan.  
 Jan rang three times after each.other prt.  
 ‘Jan rang the doorbell three times (in succession).’  
 b. Jan belde aan en hij deed dat drie keer (achter elkaar).  
 b’. Jan belde drie keer (achter elkaar) aan. → Jan belde aan.

### B. Spatial adverbial phrases

Spatial adverbial PPs such as *in het park* ‘in the park’ in (41a) are normally locational; directional PPs as well as PPs denoting change of location function as complementives and will therefore not be discussed here. The (b)-examples show once more that clauses with locational adverbial PPs satisfy the two VP-adverbial tests.

- (41) a. Jan heeft *in het park* gespeeld.  
 Jan has in the park played  
 ‘Jan has played in the park.’  
 b. Jan heeft gespeeld en hij deed dat in het park.  
 b’. Jan heeft in het park gespeeld. → Jan heeft gespeeld.

It seems that locational adverbial PPs can refer to a specific location or to a distance: in (41a) the PP *in het park* simply refers to the specific location where the eventuality of Jan playing takes place, while in (42a) the adverbial phrase refers to the distance Jan has covered by running. It might be tempting to analyze the noun phrase *de hele weg naar huis/4 kilometer* as a direct object, as would certainly be appropriate for an example such as *Jan rende de 100 meter in 12 seconden* ‘Jan ran the 100 meters in 12 seconds’, but the fact that the noun phrase can occur in a conjoined *PRONOUN doet dat* clause in (42b) is sufficient to show that this is not correct because direct objects are not able to do that.

- (42) a. Jan heeft *de hele weg naar huis/4 kilometer* gerend.  
 Jan has the whole way to home/4 kilometer run  
 ‘Jan has run the whole way home/for 4 kilometers.’  
 b. Jan heeft gerend en hij deed dat *de hele weg naar huis/4 kilometer*.  
 b’. Jan heeft *de hele weg naar huis/4 kilometer* gerend. → Jan heeft gerend.

For completeness’ sake, it should be noted that the distance reading of spatial PPs comes quite close sometimes to the duration reading of temporal PPs: the adverbial *de hele weg naar huis* in (43) can easily be construed as referring to the time span needed to cover the track.

- (43) Jan heeft *de hele weg naar huis* gekletst.  
 Jan has the whole way to home talked  
 ‘Jan has chatted the whole way home.’

Haeseryn et al. (1997:1190ff.) observe that punctual locational PPs can be relational or non-relational. Relational locational PPs denote a specific location

relative to some other location and are pronominalized by means of a pronominal PP. Non-relational locational PPs, on the other hand, refer directly to a specific place and are pronominalized by a bare R-word. Examples with relational location PPs are given in (44a). It should be noted, however, that as in the case of temporal PPs, these PPs also allow a non-relational interpretation; they can be replaced either by a pronominal PP, as in (44b), or by a bare R-word, as in (44b').

- (44) a. Jan verstoppt zich *achter/onder de bank*. [relational/non-relational]  
 Jan hides REFL behind/under the couch  
 'Jan is hiding behind/under the couch.'
- b. Jan verstoppt zich *daarachter/daaronder*. [relational]  
 Jan hides REFL there.behind/there.under  
 'Jan is hiding behind/under that.'
- b'. Jan verstoppt zich *daar*. [non-relational]  
 Jan hides REFL there  
 'Jan is hiding there.'

It is easy to construct examples in which the locational PP has an exclusive non-relational reading. This is illustrated by the PPs in (45a), which are normally replaced by a bare R-word: the pronominal PPs in (45b) give rise to a marked result and certainly cannot be construed as the counterparts of the PPs in (45a).

- (45) a. Jan werkt *in de bibliotheek/op zolder/bij Marie*. [non-relational]  
 Jan works in the library/on the.attic/with Marie  
 'Jan is working in the library/in the attic/at Marie's place.'
- b. Jan werkt *daar*<sup>#</sup>Jan werkt daar *in/op/bij*. [non-relational]  
 Jan works there/Jan works there in/on/with  
 'Jan is working there.'

Haeseryn et al. (1997:1192) claim that non-relational adverbial PPs are mainly headed by *op* and *in*, which also occur in a large set of more or less idiomatic adverbial constructions: *Jan werkt in een fabriek/op een kantoor* 'Jan works in a factory/in an office'. This claim is far too strong, however, as the examples in (44) have shown that locational PPs headed by other prepositions often allow both readings. It seems true, however, that complementive PPs are preferably assigned a relational reading when they denote a change of location. This is clear from the difference in behavior of the complementive PPs in examples (34a&b), repeated here as (46a&b): the PP in the locational construction can be replaced either by a pronominal PP or by a bare locational proform, which shows that it can have a relational or a non-relational interpretation. The PP in the change-of-location construction, on the other hand, must be replaced by a bare locational proform, which shows that it can have a non-relational interpretation only. For completeness' sake, note that the number sign in (46b') is used to indicate that the pro-form *daar* in (46b') is possible if it is interpreted as an adverbial, but this is not relevant for our present discussion.

- (46) a. Jan ligt in het zwembad. [location]  
 Jan lies in the swimming.pool  
 a'. Jan ligt erin/daar. [relational/non-relational]  
 Jan lies in.it/there  
 b. Jan valt in het zwembad. [change of location]  
 Jan falls into the swimming.pool  
 b'. Jan valt erin/#daar. [relational only]  
 Jan falls into.it/there

We provisionally conclude that adverbial locational PPs (as well as complementive PPs denoting a location) prototypically allow both a relational and non-relational reading, while complementive PPs denoting a change of location normally receive a relational reading only. We leave this as a suggestion for future research.

#### *IV. Contingency adverbials*

Contingency adverbials relate the eventuality expressed by the clause to some other concurrent circumstance. Prototypical examples are adverbial phrases indicating cause and reason; the primed examples show that these adverbials satisfy the two VP-adverbial tests. We will follow Quirk et al. (1979: Section 8.7) in assuming that cause can be established more or less objectively while reason involves a subjective and often personal assessment. The distinction can be clarified in Dutch by means of questioning: *waardoor* 'by what' normally evokes an answer providing a cause while *waarom* 'why' normally evokes an answer providing a reason.

- (47) a. De plantenpot barstte *door de vorst*. [cause]  
 the plant.pot cracked by the frost  
 'The flower pot cracked due to the frost.'  
 a'. De plantenpot barstte en hij deed dat door de vorst.  
 a''. De plantenpot barstte door de vorst. → De plantenpot barstte.  
 b. Els bleef *vanwege de regen* thuis. [reason]  
 Els stayed because.of the rain home  
 'Els stayed at home because of the rain.'  
 b'. Els bleef thuis en ze deed dat vanwege de regen.  
 b''. Els bleef thuis vanwege de regen. → Els bleef thuis.

The concessive adverbial PPs headed by *ondanks* 'despite' in (48) refer to a potential cause of an effect which did not occur, against the speaker's expectation. The primed examples show that the concessive PPs satisfy both VP-adverbial tests.

- (48) a. De plantenpot bleef *ondanks de vorst* heel. [concession]  
 the plant.pot remained despite the frost intact  
 a'. De plantenpot bleef heel en hij deed dat ondanks de vorst.  
 a''. De plantenpot bleef ondanks de vorst heel. → De plantenpot bleef heel.  
 b. Els vertrok *ondanks de regen*. [concession]  
 Els left despite the rain  
 'Els left despite the rain.'  
 b'. Els vertrok en ze deed dat ondanks de regen.  
 b''. Els vertrok ondanks de regen. → Els vertrok.

Quirk et al. (1979) show that reason is often also difficult to distinguish from purpose. The actual interpretation depends upon the point of view adopted: in an example such as (49a) earning money or getting pleasure out of it can be seen as indicating Els' motivation or goal for working here. Questioning can again help to clarify the two sides: while *waarom* 'why' calls up an answer providing a reason, *waarvoor* 'for what' evokes an answer providing a goal. Similarly, purpose and result are difficult to distinguish although the latter is often expressed by the preposition *tot*.

- (49) a. Els werkt hier *voor haar plezier/het geld*. [reason/purpose]  
 Els works here for her pleasure/the money  
 'Els enjoys working here/works here for the money.'
- a'. Els werkt hier en ze doet dat voor haar plezier/het geld.  
 a''. Els werkt hier voor haar plezier/het geld. → Els werkt hier.
- b. Els werkt hier *tot haar grote vreugde*. [result]  
 Els works here to her great pleasure  
 'Els takes great pleasure in working here.'
- b'. Els werkt hier en ze doet dat tot haar grote vreugde.  
 b''. Els werkt hier tot haar grote vreugde. → Els werkt hier.

All contingency adverbials discussed so far satisfy the two VP-adverbial tests. That they truly are VP adverbials is further supported by the fact that they may follow the modal adverbs under a neutral intonation. It should be noted, however, that at least adverbials indicating cause and reason may also precede the modal adverb, which suggests that they can also be used as clause adverbials: we return to this in Section 8.2.2, sub X.

- (50) a. De plantenpot is waarschijnlijk door de vorst gebarsten. [cause]  
 the plant.pot is probably by the frost cracked  
 'The flower pot probably cracked due to the frost.'
- b. Els bleef waarschijnlijk vanwege de regen thuis. [reason]  
 Els stayed probably because.of the rain home  
 'Els probably stayed at home because of the rain.'
- c. Els werkt waarschijnlijk *voor haar plezier/het geld*. [reason/purpose]  
 Els works probably for her pleasure the money  
 'Els probably enjoys working/works for the money.'
- d. Els werkt waarschijnlijk *tot haar grote vreugde*. [result]  
 Els works probably to her great pleasure  
 'Els probably takes great pleasure in working.'

Quirk et al. (1979) also count conditionals as contingency adverbials. We will postpone discussion of such cases to Section 8.2.2, sub X, because there is good reason to believe that they can only be used as clause adverbials. We conclude this subsection by noting that Haeseryn et al. (1997:1212) provide adverbial phrases which do not seem to fall into one of the semantic subclasses above but simply refer to a concomitant circumstance; some examples are given in (51).

- (51) a. De boot vertrok *bij slecht weer*.  
 the boat left with bad weather  
 ‘The boat left in bad weather.’
- b. Hij sliep *met open ogen*.  
 he slept with open eyes  
 ‘He slept with open eyes.’
- c. Hij vertrok *zonder te groeten*.  
 he left without to greet  
 ‘He left without saying goodbye.’

#### V. Predicate-degree adverbials

Section A3.1 has shown that there is a relatively large set of adjectival adverbials that are typically used as degree modifiers of adjectives: prototypical examples are *erg* ‘very’ and *vrij* ‘rather’ in *erg/vrij aardig* ‘very/rather nice’. A small subset of these adverbials can also be used as modifiers of verbal projections; the examples in (52) show, for example, that this is possible for the intensifier *erg* ‘very’ but not for the downtoner *vrij* ‘rather’.

- (52) a. Jan moest *erg/\*vrij* lachen.  
 Jan had.to very/rather laugh  
 ‘Jan had to laugh a lot.’
- b. De vloer kraakt *erg/\*vrij*.  
 the floor creaks very/rather  
 ‘The floor creaks terribly.’

The use of *erg* ‘very’ has more restrictions. Although it is not clear to us what precisely determines whether its use is possible or not, it seems that *erg* is common with verbs denoting involuntary bodily actions such as *niezen* ‘to sneeze’, verbs denoting a psychological state such as *zich vervelen* ‘to be bored’, verbs of sound emission such as *gillen* ‘to scream’ and weather verbs such as *vriezen* ‘to freeze’, while it is less felicitous with verbs denoting voluntary actions like *werken* ‘to work’, *fietsen* ‘to cycle’ and *praten* ‘to talk’.

- (53) a. Jan niest *erg*.  
 Jan sneezes very
- b. Marie verveelt zich *erg*.  
 Marie bores REFL very
- c. De kinderen gillen *erg*.  
 the children scream very
- d. Het vriest/waait *erg*.  
 it freezes/blows very
- (54) a. <sup>??</sup>Jan werkt/fietst *erg*.  
 Jan works/cycles very
- b. <sup>??</sup>Jan praat *erg*.  
 Jan talks very

Section A3.1 has also shown that nominal degree adverbials modifying adjectives are always downtoners: cf. *een beetje ziek* ‘a little bit sick’. The use of such modifiers as downtoners of verbal projections is quite common; they do not only occur with the verbs in (53) but also with the verbs in (54) denoting a voluntary action.

- (55) a. Jan niest een beetje.                      a'. Jan werkt/fietst een beetje.  
           Jan sneezes a bit                              Jan works/cycles a bit  
       b. Marie verveelt zich een beetje.        b'. Jan praat een beetje.  
           Marie bores REFL a bit                    Jan talks a bit

The status of the degree adverbials differs from the VP adverbials discussed in the previous subsections in that they do not provide very clear results when it comes to the *PRONOUN doet dat* + *ADVERB* paraphrase: the paraphrases of the (a)-examples in (53) and (55) in (56b) are perhaps not impossible but still feel clumsy. They do have the property, however, that they restrict the denotation of the predicate expressed by the lexical domain of the clause, as is clear from the fact that the entailment test in (56c) leads to a positive result.

- (56) a. Jan niest erg/een beetje.  
           Jan sneezes very/a bit  
       b. ?Jan niest en hij doet dat erg/een beetje.  
       c. Jan niest erg/een beetje. → Jan niest.

### 8.2.2. Clause adverbials

This section discusses various types of clause adverbials, that is, adverbials that do not restrict the denotation of the verbal predicate but provide other, additional, information. The meaning contributions of these adverbials are quite varied: their main similarity is that they are located external to the lexical domain of the clause. The following subsections will discuss the subclasses in (57).

- (57) a. Polarity: negation (*niet* 'not'); affirmation (*wel*)  
       b. Focus particles: *alleen* 'only', *ook* 'too', *zelfs* 'even', etc.  
       c. Aspectual: habitual; iterative; frequentative; continuative; etc.  
       d. Clause-degree (*bijna* 'nearly'; *amper* 'hardly', etc.)  
       e. Propositional modal (*waarschijnlijk* 'probably'; *blijkbaar* 'apparently')  
       f. Subject-oriented (*stom genoeg* 'stupidly', *wijselijk* 'wisely', etc.)  
       g. Subjective: factive (*helaas* 'unfortunately'); non-factive  
       h. Point-of-view (*volgens Els* 'according to Els')  
       i. Spatio-temporal: place; time  
       j. Contingency: cause; reason; condition; concession  
       k. Domain (*juridisch gezien* 'legally', *moreel gezien* 'morally', etc.)  
       l. Conjunctive (*echter* 'however', *derhalve* 'therefore', etc.)  
       m. Speech-act related (*eerlijk gezegd* 'honestly', etc.)

We will investigate to what extent these adverbial types satisfy the scope test proposed in Section 8.1, sub III, repeated here as (58a): the test is illustrated in (58b) by means of the prototypical clause adverbial *waarschijnlijk* 'probably'.

- (58)     • Clause-adverbial test: scope paraphrase  
       a. [<sub>CLAUSE</sub> ... ADVERBIAL [<sub>VP</sub> ...]] ⇒ Het is ADVERBIAL zo [<sub>CLAUSE</sub> dat ... [<sub>VP</sub> ...]]  
       b. Jan lacht waarschijnlijk. ⇒ Het is waarschijnlijk zo dat Jan lacht.  
           Jan laughs probably                      it is probably                      the.case that Jan laughs



*I. Polarity adverbials*

This section discusses the negative adverb *niet* ‘not’ and its affirmative counterpart *wel* in (59). Note in passing that the adverb *niet* can also be used as constituent negation (cf. Section 13.3.2, sub IC), and that both *niet* and *wel* can also be used as intensifiers of adjectives; *Jan is niet onaardig/Jan is wel aardig* ‘Jan is quite nice’ (cf. Section A3.3). These uses will not be discussed here.

- (59) a. Jan heeft Marie *niet* ontmoet. [sentence negation]  
 Jan has Marie not met  
 ‘Jan hasn’t met Marie.’  
 b. Jan heeft Marie *wel* ontmoet. [affirmation]  
 Jan has Marie AFF met  
 ‘Jan did meet Marie.’

Polarity adverbials are clearly not VP adverbials, as is shown by the fact that the sentences in (59) do not satisfy the two VP-adverbial tests. The primeless examples in (60) first show that the *PRONOUN doet dat* + *ADVERB* paraphrase does not give rise to a felicitous result: the left-right arrow with a slash ( $\nrightarrow$ ) indicates that it leads to a contradiction in the case of *niet* ‘not’ and the left-right arrow without a slash ( $\rightarrow$ ) indicates that it leads to a tautology in the case of *wel*. The primed examples show that the entailment test also fails: the entailment holds in neither direction in the case of *niet* and in both directions in the case of *wel* (at least in as far as the meaning expressed by traditional predicate calculus is concerned).

- (60) a. <sup>S</sup>Jan heeft Marie ontmoet en hij deed dat niet. [sentence negation]  
 Jan has Marie met and he did that not  
 a'. Jan heeft Marie niet ontmoet.  $\nrightarrow$  Jan heeft Marie ontmoet.  
 b. <sup>S</sup>Jan heeft Marie ontmoet en hij deed dat wel. [affirmation]  
 Jan has Marie met and he did that AFF  
 b'. Jan heeft Marie wel ontmoet.  $\rightarrow$  Jan heeft Marie ontmoet.

Polarity adverbials take scope over the proposition expressed by the lexical domain of the clause. This is the standard assumption for negation in predicate calculus, which treats negation as an operator taking scope over a well-formed expression  $\Phi$ :  $\neg\Phi$ . It is also clear from the fact that both negative and affirmative clauses pass the scope test in (58a): the examples in (59) can easily be paraphrased by the examples in (61).

- (61) a. Het is niet zo dat Jan Marie heeft ontmoet. [sentence negation]  
 it is not the.case that Jan Marie has met  
 ‘It is not the case that Jan has met Marie.’  
 b. Het is wel zo dat Jan Marie heeft ontmoet. [affirmation]  
 it is AFF the.case that Jan Marie has met  
 ‘It IS the case that Jan has met Marie.’

The polarity adverbials are located very low in the functional domain of the clause: they must be preceded by all the clause adverbials that will be discussed in the following subsections. This shows immediately that these other adverbials are also

part of the functional domain of the clause and thus cannot function as VP adverbials, cf. Section 8.1, sub II.

It should also be pointed out that the negative adverbial *niet* is probably not in an adjoined position, but located in the specifier of a functional projection (NegP): the reason for assuming this is that this position is not only accessible to *niet* but arguably also functions as a landing site for negative phrases. This is especially clear if the negative phrase is part of a PP-complement of a complementive adjective, as in (62): while there is good reason for assuming that the PP is base-generated in a position following the adjective, it must occur in a position preceding the adjective if the nominal part of the PP is a negative phrase such as *niemand* ‘nobody’. This would follow if we assume that a negative phrase must be moved into the specifier of NegP, as indicated in (62c), in order for negation to be assigned scope over the complete proposition. We will not digress on this here but refer the reader to Section 13.3.1 for detailed discussion.

- (62) a. dat Jan erg dol op Peter/\*niemand is.  
 that Jan very fond of Peter/nobody is  
 ‘that Jan is very fond of Peter.’
- b. dat Jan op niemand erg dol is.  
 that Jan of nobody very fond is  
 ‘that Jan isn’t very fond of anybody.’
- c. dat Jan [<sub>NegP</sub> [<sub>PP</sub> op niemand]<sub>i</sub> Neg [<sub>VP</sub> ... [<sub>AP</sub> erg dol *t<sub>i</sub>*] is]].  
 that Jan of nobody very fond is

We want to conclude this section by noting that the semantic contributions of the two polarity adverbials differ considerably: from a logical point of view, the negative adverbial *niet* is needed to express negation (unless it is expressed in some other way) while the affirmative marker is superfluous. This is demonstrated in (63): omission of *niet* results in an affirmative expression whereas omission of *wel* results in a logically equivalent expression.

- (63) a. Jan heeft Marie (<sup>#</sup>niet) ontmoet. [sentence negation]  
 Jan has Marie not met  
 ‘Jan hasn’t met Marie.’
- b. Jan heeft Marie (wel) ontmoet. [affirmation]  
 Jan has Marie AFF met  
 ‘Jan did meet Marie.’

It is therefore not surprising that the use of the affirmative marker *wel* is mainly pragmatically motivated: it is used to indicate contrast, to deny an assertion or a presupposition held by the hearer, to make a concession, etc. Illustrations are given in (64). The affirmative marker *wel* thus plays a prominent role in signaling that the background (the shared information of the discourse participants) needs to be updated, and its heavy informational load may be the reason why affirmative *wel* is always accented (contrary to the modifier *wel* discussed in Section A3.3, which never carries accent).

- (64) a. Ik kom vandaag niet, maar morgen wel. [contrast]  
 I come today not but tomorrow AFF  
 'I won't come today but tomorrow I will.'
- b. A. Je komt morgen toch niet? B. Ik kom wel. [denial]  
 you come tomorrow PRT not I come AFF  
 'You won't come tomorrow, will you? I WILL come.'
- c. Ik kom morgen, maar wel wat later. [concession]  
 I come tomorrow but AFF somewhat later  
 'I will come tomorrow, but it will be a bit later.'

## II. Focus particles

Sentence negation can be preceded by focus particles such as *alleen* 'just/only', *ook* 'also', and *zelfs* 'even'. A number of typical examples are given in the primeless examples in (65). That these particles function as clause adverbials is clear from the fact that they satisfy the scope test in (58a), as is shown in the primed examples.

- (65) a. Jan is een goed geleerde; hij is *alleen* niet geschikt als decaan.  
 Jan is a good scholar he is only not suitable as dean  
 'Jan is a good scholar; he is just not suitable as Dean.'
- a'. Het is alleen zo dat hij niet geschikt is als decaan.  
 it is only the.case that he not suitable is as dean
- b. Marie komt morgen niet en Jan komt *ook* niet.  
 Marie comes tomorrow not and Jan comes also not  
 'Marie won't come tomorrow and Jan won't come either.'
- b'. Het is ook zo dat Jan niet komt.  
 it is also the.case that Jan not comes
- c. Jan heeft het druk: hij gaat *zelfs* niet op vakantie.  
 Jan has it busy he goes even not on vacation  
 'Jan is busy; he will not even take a vacation.'
- c'. Het is zelfs zo dat hij niet op vakantie gaat.  
 it is even the.case that he not on vacation goes

As in the case of negation, there are reasons for assuming that focus particles are not in an adjoined position but in the specifier position of a functional projection (FocusP). In order to show this, it should first be noted that focus particles are not only used as independent adverbials but can also be used as narrow focus markers, in which case they form a constituent with the focused phrase. This can be seen in the examples in (66); the fact that the particle and the focused phrase co-occur in clause-initial position shows that they must be a constituent (cf. °constituency test).

- (66) a. [Alleen als decaan] is Jan niet geschikt.  
 only as dean is Jan not suitable
- b. [Ook Jan] komt morgen niet.  
 also Jan comes tomorrow not
- c. [Zelfs op vakantie] gaat Jan niet.  
 even on vacation goes Jan not

The reason for assuming that the focus particles are in the specifier of FocusP is that this position is not accessible to focus particles only; it also functions as a landing site for narrowly focused phrases. This is especially clear if the focused phrase is a PP-complement of a complementive adjective, as in (67). It is uncontroversial that the PP is base-generated in a position following the adjective; however, it must precede the adjective if it is narrowly focused. This would follow if we assume that narrowly focused phrases must be moved into the specifier of FocusP, as indicated in (67c), in order to be assigned scope over the backgrounded part of the clause. We do not digress on this here but refer the reader to Section 13.3.2, sub IC, which also discusses a number of other focus particles.

- (67) a. dat Jan erg dol (\*zelfs) op Peter is.  
that Jan very fond even of Peter is  
'that Jan is very fond of Peter.'
- b. dat Jan zelfs op Peter erg dol is.  
that Jan even of Peter very fond is  
'that Jan is even very fond of Peter.'
- c. dat Jan [<sub>FocusP</sub> [<sub>PP</sub> zelfs op Peter]<sub>i</sub> Focus ... [<sub>VP</sub> ... [<sub>AP</sub> erg dol *t<sub>i</sub>*] is]].  
that Jan even of Peter very fond is

### III. Aspectual adverbials

Sentence negation can also be preceded by aspectual adverbs such as habitual *gewoonlijk* 'usually', continuative *nog* (*steeds*) 'still', terminative *niet meer* 'no longer', iterative *weer* 'again', and frequentative *vaak* 'often'. Other adverbials that may belong to this group are *al* 'already' and *spoedig* 'soon' but these do not easily co-occur with the sentence adverbial *niet*. Some instances are provided in the primeless examples in (68); the primed examples show that these adverbials satisfy the scope test in (58a).

- (68) a. dat Jan *gewoonlijk* niet aanwezig is.  
that Jan usually not present is  
'that Jan usually isn't present.'
- a'. Het is *gewoonlijk* zo dat Jan niet aanwezig is.  
it is usually the.case that Jan not present is
- b. dat Jan *nog* *steeds* niet aanwezig is.  
that Jan still not present is  
'that Jan still isn't present.'
- b'. Het is *nog* *steeds* zo dat Jan niet aanwezig is.  
it is still the.case that Jan not present is
- c. dat Jan *vaak* niet aanwezig is.  
that Jan often not present is  
'that Jan often isn't present.'
- c'. Het is *vaak* zo dat Jan niet aanwezig is.  
it is often the.case that Jan not present is

It should be noted that the frequency adverb *vaak* 'often' can also be used as a VP adverbial; cf. Section 8.2.1, sub IIIA. The examples in (69) illustrate this by showing that it may either precede or follow the negative adverb *niet* 'not'. The two

examples differ in the relative scope of the adverbials *vaak* and *niet*, which can be brought out by the paraphrases in the primed examples.

- (69) a. dat Jan niet vaak aanwezig is. [VP adverbial: not > often]  
 that Jan not often present is  
 'that Jan isn't present often.'  
 a'. Het is niet zo dat Jan vaak aanwezig is.  
 it is not the.case that Jan often present is  
 'It is not the case that Jan is present often.'  
 b. dat Jan vaak niet aanwezig is. [clause adverbial: often > not]  
 that Jan often not present is  
 'that Jan often isn't present.'  
 b'. Het is vaak zo dat Jan niet aanwezig is.  
 it is often the.case that Jan not present is  
 'It is often the case that Jan isn't present.'

The scope difference becomes even clearer with frequency adverbials such as *drie keer* 'three times'. Suppose we are dealing with a sequence of four lectures; then example (70a) expresses that Jan attended less than three meetings while (70b) expresses that Jan attended only one lecture. Example (70c) shows that the two uses can co-occur in a single sentence: in case we are dealing with six sequences of four lectures, (70c) expresses that for two of these sequences Jan attended less than three lectures.

- (70) a. dat Jan niet drie keer aanwezig is geweest. [VP adverbial]  
 that Jan not three times present is been  
 'that Jan hasn't been present three times.'  
 b. dat Jan drie keer niet aanwezig is geweest. [clause adverbial]  
 that Jan three times not present is been  
 'that three times Jan hasn't been present.'  
 c. dat Jan twee keer niet drie keer aanwezig is geweest. [co-occurrence]  
 that Jan two times not three times present is been  
 'that twice (in two sequences) Jan hasn't been present three times.'

A more complicated class of adverbs that may be considered aspectual consists of the adverbs *helemaal* 'completely' and *gedeeltelijk* 'partly' in (71a), which indicate whether the eventuality was or was not completely finished. That these adverbs are not VP adverbials is clear from the fact that they do not restrict the denotation of the verbal predicate, as appears from the fact that the entailment test in (71b) fails in the case of *gedeeltelijk*. However, it is not immediately evident either that these adverbs function as clause adverbials, as is clear from the fact that the scope test in (71c) produces questionable results.

- (71) a. Jan heeft de appel helemaal/gedeeltelijk opgegeten.  
 Jan has the apple completely/partly prt.-eaten  
 'Jan has completely/partly eaten the apple.'  
 b. Jan heeft de appel gedeeltelijk opgegeten. → Jan heeft de appel opgegeten.  
 c. ?Het is helemaal/gedeeltelijk zo dat Jan de appel heeft opgegeten.  
 it is completely/partly the.case that Jan the apple has eaten

There are nevertheless good reasons for supposing that we are dealing with clause adverbials, given that the adverb *gedeeltelijk* 'partly' can precede sentence negation; cf. (72). It should be noted that the order *niet gedeeltelijk* is also possible if the adverb is accented; this case can be put aside because we are probably dealing with constituent negation in that case. Note also that examples similar to (72) are difficult to construct for *helemaal*, due to the fact that this adverb can be construed as a modifier of negation in *helemaal niet* 'absolutely not'.

- (72) Jan heeft de film gedeeltelijk niet gezien.  
 Jan has the movie partly not prt.-seen  
 'Jan missed a part of the movie.'

#### IV. Clause-degree adverbials

Adverbs like *bijna* 'almost', *echt* 'really', and *haast* 'nearly' are referred to as clause-degree adverbs by Ernst (2002). These are clear cases of clause adverbials: they satisfy the scope test.

- (73) a. Jan ging bijna kwaad weg.  
 Jan went almost angry away  
 'Jan almost went away angry.'  
 a'. Het was bijna zo dat Jan kwaad weg ging.  
 it was nearly the.case that Jan angry away went  
 b. Jan werd haast overreden.  
 Jan was nearly run.over  
 'Jan was nearly run over (by a car).'  
 b'. Het was haast zo dat Jan werd overreden.  
 it was nearly the.case that Jan was run-over

It may be the case that (inherently negative) adverbs like *amper* 'hardly' and *nauwelijks* 'scarcely' in (74a) belong to the same class, although (74b) shows that they do not pass the scope paraphrase in a convincing way. We leave the problem with these adverbials for future research.

- (74) a. Jan was amper/nauwelijks thuis toen Marie belde.  
 Jan was hardly/scarcely home when Marie called  
 'Jan was hardly/scarcely home when Marie called.'  
 b. <sup>S</sup>Het was amper/nauwelijks zo dat Jan thuis was toen Marie belde.  
 it was hardly/scarcely the.case that Jan home was when Marie called

#### V. Propositional modal adverbials

Propositional modality provides an evaluation of the factual status of propositions expressed by the lexical projection of the main verb. By uttering a sentence such as *Marie is thuis* 'Marie is at home' the speaker normally commits himself to the truth of the proposition expressed by the lexical projection of the main verb. The speaker may, however, also comment on the factual status of the proposition. Palmer (2001) claims that these judgments may be of two different kinds: there are epistemic and evidential judgments. Epistemic judgments are concerned with the likelihood of the actual occurrence of a specific eventuality. Section 5.2.3.2, sub IIIA1, has shown

that epistemic judgments can be expressed by means of modal verbs such as *kunnen* ‘may’, *moeten* ‘must’ and *zullen* ‘will’.

- (75) a. Marie kan nu thuis zijn. [speculative]  
 Marie may now at.home be  
 b. Marie moet nu thuis zijn. [deductive]  
 Marie must now at.home be  
 c. Marie zal nu thuis zijn. [assumptive]  
 Marie will now at.home be

By uttering sentences such as (75a-c), the speaker provides three different epistemic judgments about (his commitment to the truth of) the proposition BE AT HOME (*Marie*). The modal verb *kunnen* ‘may’ presents the proposition as a *possible* conclusion: the speaker is uncertain whether the proposition is true, but on the basis of the information available to him he is not able to exclude it. The modal verb *moeten* ‘must’ presents the proposition as the *only possible* conclusion: on the basis of the information available the speaker infers that the proposition is true. The modal verb *zullen* ‘will’ presents the proposition as a *reasonable* inference on the basis of the available evidence. A wider range of epistemic judgments can be expressed by means of the adverbial phrases in (76a).

- (76) a. Epistemic adverbials: *gegarandeerd* ‘certainly’, *hoogstwaarschijnlijk* ‘most likely’, *misschien* ‘maybe’, *mogelijk* ‘possibly’, *naar alle waarschijnlijkheid* ‘in all probability’, *natuurlijk* ‘naturally/of course’, *noodzakelijk(erwijs)* ‘necessarily’, *ongetwijfeld* ‘undoubtedly’, *vermoedelijk* ‘supposedly’, *waarschijnlijk* ‘probably’, *zeker* ‘certainly’, etc.  
 b. Marie is misschien/zeker/natuurlijk/... thuis.  
 Marie is maybe/certainly/naturally at.home

Evidential judgments are concerned with the source of information that the judgment is based on: cf. Section 5.2.3.2, sub IIIA2. Perception verbs such as *zien* ‘to see’, for instance, are used in °AcI-constructions such as *Ik zag Peter vertrekken* ‘I saw Peter leave’ to express that the evidential judgment is based on direct sensory evidence: the speaker was an eye-witness of the eventuality. And modal verbs such as *blijken* ‘to turn out’, *lijken* ‘to appear’, and *schijnen* ‘to seem’ indicate whether there is direct evidence in favor of the truth of the proposition, whether there are identifiable individuals that can be held responsible for the truth of the proposition, or whether we are dealing with hearsay/rumors; see Vliegen (2011).

- (77) a. Uit deze feiten blijkt [dat Jan de dader is]. [direct evidence]  
 from these facts turns.out that Jan the perpetrator is  
 ‘These facts clearly show that Jan is the perpetrator.’  
 b. Het lijkt mij/haar [dat Jan de dader is]. [identifiable source]  
 it appears me/her that Jan the perpetrator is  
 ‘It appears to me/her that Jan is the perpetrator.’  
 c. Het schijnt [dat Jan de dader is]. [hearsay/rumors]  
 it seems that Jan the perpetrator is  
 ‘It seems that Jan is the perpetrator.’



Again a wider range of evidential judgments can be expressed by means of the adverbial phrases in (78a):

- (78) a. Evidential adverbials: *blijkbaar* ‘evidently’, *duidelijk* ‘clearly’, *evident* ‘evidently’, *kennelijk* ‘obviously’, *klaarblijkelijk* ‘apparently’, *ogenschijnlijk* ‘apparently’, *onmistakbaar* ‘unmistakably’, *schijnbaar* ‘seemingly’, *vermoedelijk* ‘probably’, *zichtbaar* ‘visibly/evidently’, *zo te zien* ‘apparently/by the looks of it’, etc.
- b. Jan is *blijkbaar/duidelijk/zo te zien/...* de dader.  
Jan is evidently/clearly/by the looks of it/ ... the perpetrator

The propositional modal adverbials in (76a) and (78a) satisfy the scope-adverbial test in (58a), as is illustrated in (79) for the examples in (76b) and (78b). That epistemic modal adverbials allow the scope paraphrase is also in conformity with the fact that epistemic judgments are expressed in formal logic by means of the operators  $\square$  and  $\diamond$ , which take scope over a well-formed expression  $\Phi$ :  $\square\Phi$  and  $\diamond\Phi$ .

- (79) a. Het is misschien/zeker/natuurlijk zo dat Marie thuis is.  
it is maybe/certainly/naturally the.case that Marie at.home is  
‘It is maybe/certainly/naturally the case that Marie is at home.’
- b. Het is *blijkbaar/duidelijk/zo te zien zo* dat Jan de dader is.  
it is evidently/clearly/apparently the.case that Jan the perpetrator is  
‘Evidently/Clearly/By the looks of it, it is the case that Jan is the perpetrator.’

## VI. Subject-oriented adverbials

Subject-oriented adverbials like *slim genoeg* ‘cleverly’ and *wijselijk* ‘wisely’ in (80) provide the speaker’s subjective evaluation of the subject of the clause in relation to the predicate expressed by the lexical projection of the verb. Example (80a) expresses that the speaker considers Jan clever for not attending the performance and (80b) that he considers Marie wise for not contradicting Peter.

- (80) a. Jan vertrok *slim genoeg* voor de voorstelling.  
Jan left clever enough before the performance  
‘Jan cleverly left before the performance.’
- b. Marie sprak Peter *wijselijk* niet tegen.  
Marie said Peter wisely not against  
‘Marie wisely didn’t contradict Peter.’

Example (80b) shows that subject-oriented adverbials may precede negation. The fact that the reverse order gives rise to a marginal result also suggests that they function as clause adverbials. Even more support is that they do not restrict the denotation of the predicate, as (81) clearly shows that the examples in (80) cannot be paraphrased by means of a conjoined *PRONOUN doet dat + ADVERB* clause. Note in passing that the paraphrase *Jan vertrok en hij deed dat slim genoeg voor de voorstelling* is acceptable but involves restricted scope of the subject-oriented adverb over the time adverbial. The acceptability of this paraphrase is consequently not relevant here; see Section 8.1, sub III, for discussion.



- (81) a. \*Jan vertrok voor de voorstelling en hij deed dat slim genoeg.  
 Jan left before the performance and he did that clever enough  
 b. \*Marie sprak Peter niet tegen en zij deed dat wijselijk.  
 Marie said Peter not against and she did that wisely

The examples in (82) show that scope paraphrases are not possible either. However, this is understandable in the light of the fact that the matrix clauses in these paraphrases do not contain a suitable subject that the adverbial could be applied to: the paraphrases are uninterpretable as a result.

- (82) a. <sup>S</sup>Het is slim genoeg zo dat Jan voor de voorstelling vertrok.  
 it is clever enough the.case that Jan before the performance left  
 b. <sup>S</sup>Het is wijselijk zo dat Marie Peter niet tegensprak.  
 it is wisely the.case that Marie Peter not contradicted

For completeness' sake, it should be noted that the examples in (80) can be paraphrased as in (83). These paraphrases suggest that subject-oriented adverbials have scope over the proposition expressed by the lexical domain of the clause. We will not push this idea any further but provisionally assume that the infelicity of the scope paraphrases in (82) is indeed due to the fact that they do not contain a suitable subject that the adverbial could be applied to.

- (83) a. Het is slim van Jan dat hij voor de voorstelling vertrok.  
 it is clever of Jan that he before the performance left  
 b. Het is wijs van Marie dat zij Peter niet tegensprak.  
 it is wise of Marie that she Peter not contradicted

### VII. Subjective adverbials

Subjective adverbials specify a specific mental attitude towards the state-of-affairs referred to by the clause. These adverbials are difficult to distinguish from the epistemic adverbials because they also comment on the factual status of the proposition in that they express that the proposition is or is not necessarily/yet true.

- (84) • Subjective adverbials  
 a. Factive: *begrijpelijkerwijs* 'understandably', *helaas* 'unfortunately', *gelukkig* 'fortunately', *jammer* genoeg 'regrettably', *(on)gelukkigerwijs* '(un)fortunately', *vanzelfsprekend* 'obviously/self-evidently'  
 b. Non-factive: *hopelijk* 'hopefully'

However, the main informational load of these adverbials involves a subjective evaluation of the eventuality. By uttering (85a) the speaker expresses that the proposition expressed by the clause is true while the two adverbials *gelukkig* and *helaas* reveal that the speaker has either a positive or a negative attitude toward the eventuality of 'Jan having arrived on time'. By uttering (85b) the speaker expresses that he does not know whether the proposition expressed by the clause is true, but that he would consider it a good thing if it were true.

- (85) a. Jan is gelukkig/helaas op tijd gearriveerd.  
 Jan is fortunately/unfortunately on time arrived  
 'Jan has fortunately/unfortunately arrived on time.'
- b. Jan is hopelijk op tijd gearriveerd.  
 Jan is hopefully on time arrived  
 'Jan has hopefully arrived on time.'

Example (85b) is clearly not epistemic as the speaker does not provide an evaluation of the factual status of the proposition. This is different with adverbial phrases such as *naar ik hoop/vrees* in (86): these adverbials are subjective in that they provide an evaluation of the proposition, but they are also epistemic in that the speaker expresses that the proposition is a *reasonable* conclusion on the basis of the evidence available to him. Since the epistemic verb *vermoeden* 'to suspect' can also be used in this phrase, it is not evident that the adverbial phrase *naar ik +V* should be considered intrinsically subjective in nature.

- (86) Jan is naar ik hoop/vrees/vermoed op tijd gearriveerd.  
 Jan is as I hope/fear/suspect on time arrived  
 'Jan has arrived on time, I hope/fear/suspect.'

That subjective adverbials are clause adverbials is clear from the fact that they satisfy the scope test; this is illustrated in (87a&b) for the examples in (85). For completeness' sake we have added the paraphrase in (87c) for the examples in (86).

- (87) a. Het is gelukkig/helaas zo dat Jan op tijd gearriveerd is.  
 it is fortunately/unfortunately the.case that Jan on time arrived is
- b. Het is hopelijk zo dat Jan op tijd gearriveerd is.  
 it is hopefully the.case that Jan on time arrived is
- c. Het is naar ik hoop/vrees/vermoed zo dat Jan op tijd gearriveerd is.  
 it is as I hope/fear/suspect the.case that Jan on time arrived is

Other examples of subjective adverbials are *toch*, *maar*, *dan*, and *nou*. These particle-like items often occur in combination and may express various, often subtle, meaning modulations of the sentence; cf. Haeseryn et al. (1997;457/1349).

### VIII. Point-of-view adverbials

In the linguistic literature on English since Jackendoff (1972) epistemic adverbials have been classified as speaker-oriented adverbs. The epistemic judgments of the proposition are normally taken to be the speaker's, that is, by uttering the sentence in (88) the speaker takes responsibility for the truth of the assertion that Jan will visit us.

- (88) Jan komt zeker op visite.  
 Jan comes certainly on visit  
 'Jan will certainly visit us.'

Although the speaker-oriented reading of epistemic adverbials is certainly their default interpretation, it is not semantically determined but it is the result of a pragmatic implicature. This is evident from the fact that the speaker's responsibility

for the truth of the assertion can be made explicit or be canceled by adding an adverbial phrase indicating the person responsible for the truth of the relevant information: some more or less fixed expressions for, respectively, emphasizing and canceling of the speaker's responsibility are given in (89).

- (89) • Point-of-view adverbials:
- Making explicit the speaker's responsibility: *bij/naar mijn/ons weten* 'as far as I/we know', *mijns/ons inziens* 'in my/our view', *naar mijn/onze mening* 'according to my/our opinion', *naar mijn/onze overtuiging* (lit.: "according to my/our conviction"), etc.
  - Canceling the speaker's responsibility: *blijkens dit rapport* 'according to this report', *zijns inziens* 'in his view', *naar verluidt* 'according to reports', etc.

A common productive way of expressing a point-of-view is using a PP headed by the preposition *volgens* 'according to': by using *volgens mij* 'according to me' in (90a) the speaker makes his responsibility for the truth of assertion explicit, while he shifts this responsibility to Els by using *volgens Els* in (90b). Example (90c) shows that point-of-view adverbials pass the scope test.

- (90) a. Jan komt volgens mij zeker op visite. [speaker's responsibility]  
 Jan comes according.to me certainly on visit  
 'According to me, Jan will certainly come and visit us.'
- b. Jan komt volgens Els zeker op visite. [not speaker's responsibility]  
 Jan comes according.to Els certainly on visit  
 'According to Els, Jan will certainly come and visit us.'
- c. Het is volgens mij/Els zo dat Jan zeker op visite komt.  
 it is according me/Els the.case that Jan certainly on visit comes  
 'According to me/Els, it is the case that Jan will certainly come and visit us.'

Subjective adverbials like *gelukkig* 'fortunately' and *helaas* 'unfortunately' are normally also considered to be speaker-oriented. This may seem justifiable in (91): the assessment of Jan's dismissal as a fortunate event can be attributed to the speaker despite the presence of the point-of-view PP *volgens Els* 'according to Els'. However, it also seems possible to attribute this assessment to Els, as is clear from the fact that the part in parentheses can be added without creating a contradiction. The speaker-oriented reading of evaluation adverbials may therefore still be a pragmatic effect; we leave this issue to future research.

- (91) Jan is volgens Els gelukkig ontslagen (maar ik vind het naar).  
 Jan is according.to Els fortunately fired but I find it unpleasant  
 'According to Els, it's a stroke of luck that Jan was fired (but I think it's terrible).'

### IX. Spatio-temporal adverbials

Spatio-temporal adverbials are not only used as VP adverbials (cf. Section 8.2.1, sub III) but also as clause adverbials. That temporal adverbials may be ambiguous in this way is demonstrated in (92); the primeless examples show that these adverbials can either precede or follow a modal adverb such as *waarschijnlijk* 'probably', and the primed examples show that they pass both the clause-adverbial and the VP-adverbial test.

- (92) a. Jan komt *morgen* waarschijnlijk op visite. [clause adverbial]  
 Jan comes tomorrow probably on visit  
 'Jan will probably visit us tomorrow.'
- a'. Het is morgen waarschijnlijk zo dat Jan op visite komt.  
 it is tomorrow probably the.case that Jan on visit comes
- b. Jan komt waarschijnlijk *om drie uur* op visite. [VP adverbial]  
 Jan comes probably at 3 o'clock on visit  
 'Jan will probably visit us at 3 o'clock.'
- b'. Jan komt waarschijnlijk op visite en hij doet dat om 3 uur.  
 Jan comes probably on visit and he does that at 3 o'clock

The examples in (93) show that the two time adverbials *morgen* and *om drie uur* in (92) may co-occur but that they obey certain ordering restrictions: the time interval referred to by the clause adverbial includes the time (interval) referred to by the VP adverbial. Since (93b) becomes fully acceptable if one of the two time adverbials is omitted, it is not likely that we are dealing with a syntactic restriction; Section 8.2.3 will argue that this restriction is semantic in nature, for which reason we have marked the deviating order in (93b) with a dollar sign.

- (93) a. Jan komt *morgen* waarschijnlijk *om drie uur* op visite.  
 Jan comes tomorrow probably at 3 o'clock on visit  
 'Jan will probably visit us at 3 o'clock tomorrow.'
- b. <sup>\$</sup>Jan komt *om drie uur* waarschijnlijk *morgen* op visite.  
 Jan comes at 3 o'clock probably tomorrow on visit

For locational adverbials we can make more or less the same observations. The examples in (94) first illustrate that locational adverbials can either precede or follow a modal adverb and that they pass both the clause-adverbial test in (94a') and the VP-adverbial test in (94b').

- (94) a. Jan geeft *in Amsterdam* waarschijnlijk een lezing. [clause adverbial]  
 Jan gives in Amsterdam probably a talk  
 'Jan will probably give a talk in Amsterdam.'
- a'. Het is in Amsterdam waarschijnlijk zo dat Jan een lezing geeft.  
 it is in Amsterdam probably the.case that Jan a talk gives
- b'. Jan geeft waarschijnlijk een lezing *op de universiteit*. [VP adverbial]  
 Jan gives probably a talk at the university  
 'Jan will probably give a talk at the university.'
- b'. Jan geeft waarschijnlijk een lezing en hij doet dat op de universiteit.  
 Jan gives probably a talk and he does that at the university

The examples in (95) show that the two place adverbials in (94) may co-occur but that they obey certain ordering restrictions: the location referred to by the clause adverbial includes the location referred to by the VP adverbial. Since (95b) becomes fully acceptable if one of the two locational adverbials is omitted, it is again not likely that we are dealing with a syntactic restriction, for which reason we have marked the deviating order in (95b) with a dollar sign.

- (95) a. Jan geeft *in Amsterdam* waarschijnlijk een lezing *op de universiteit*.  
 Jan gives in Amsterdam probably a talk at the university  
 ‘In Amsterdam Jan will probably give a talk at the university.’  
 b. <sup>s</sup>Jan geeft *op de universiteit* waarschijnlijk een lezing *in Amsterdam*.  
 Jan gives at the university probably a talk in Amsterdam

### X. Contingency adverbials

Section 8.2.1, sub IV, has shown that adverbials indicating cause and reason can be used as VP adverbials. The fact illustrated in (96) that these adverbials may occur on either side of the modal *waarschijnlijk* ‘probably’ suggests, however, that they can also be used as clause adverbials.

- (96) a. De pot is waarschijnlijk door de vorst gebarsten. [VP/cause]  
 the pot is probably by the frost cracked  
 ‘The pot has probably cracked because of frost.’  
 a’. De pot is door de vorst waarschijnlijk gebarsten. [clause/cause]  
 the pot is by the frost probably cracked  
 ‘Because of frost the pot has probably cracked.’  
 b. De winkel is waarschijnlijk vanwege Pasen gesloten. [VP/reason]  
 the shop is probably because.of Easter closed  
 ‘The shop is probably closed because of Easter.’  
 b’. De winkel is vanwege Pasen waarschijnlijk gesloten. [clause/reason]  
 the shop is because.of Easter probably closed  
 ‘Because of Easter, the shop is probably closed.’

That the adverbials indicating cause or reason are clause adverbials in the primed examples in (96) is given greater credence by the fact that these examples can easily be paraphrased by means of the scope paraphrases in (97).

- (97) a. Het is door de vorst waarschijnlijk zo dat de pot gebarsten is.  
 it is by the frost probably the.case that the pot cracked is  
 b. Het is vanwege Pasen waarschijnlijk zo dat de winkel gesloten is.  
 it is because of Easter probably the.case that the shop closed is

The semantic difference between the primeless and primed examples in (96) is genuinely a matter of relative scope: in the primeless examples the adverbials indicating cause and reason are in the scope of the modal adverb *waarschijnlijk*, while they are not in the scope of the adverb in the primed examples. This induces the following meaning differences: example (96a) expresses that the pot has probably cracked as a result of frost, while (96a’) expresses that the frost is a good reason for assuming that the pot has cracked; example (96b) expresses that the shop is probably closed because of Easter, while (96b’) expresses that Easter is a good reason for assuming that the shop is closed.

The concessive counterparts of the cause/reason adverbials may likewise be used as clause adverbials; the examples in (98) illustrate this by showing that these adverbials can easily occur in front of the modal *waarschijnlijk* ‘probably’.

- (98) a. De pot is *ondanks de vorst* waarschijnlijk heel gebleven. [concession]  
 the pot is despite the frost probably intact remained  
 'The pot has probably remained undamaged despite the frost.'
- b. Els is *ondanks de regen* waarschijnlijk vertrokken. [concession]  
 Els is despite the rain probably left  
 'Els has probably left despite the rain.'

Conditionals differ from adverbials indicating cause and reason in that they always function as clause adverbials. Although conditionals are normally expressed by means of adverbial clauses, there are also a number of more or less idiomatic prepositional phrases headed by *in* 'in' and *bij* 'with'; cf. Haeseryn et al. (1997:1209). Two typical cases are given in the primeless examples in (99). These conditional adverbials do not restrict the denotation of the verbal predicate, as is clear from the fact illustrated in the singly-primed examples that they do not satisfy the entailment test. Furthermore, the scope paraphrase in the doubly-primed examples seems perfectly adequate. This leads to the conclusion that conditional adverbials differ from adverbials indicating cause and reason in that they function as clause adverbials only.

- (99) a. Wij helpen u *in noodgevallen* direct.  
 we help you in emergencies immediately  
 'We will help you immediately in case of an emergency.'
- a'. Wij helpen u in noodgevallen direct. → Wij helpen u direct.
- a''. Het is in noodgevallen zo dat wij u direct helpen.  
 it is in emergencies the.case that we you promptly help
- b. *Bij diefstal* bellen wij altijd de politie.  
 in.case.of theft phone we always the police  
 'In case of theft, we always call the police.'
- b'. Bij diefstal bellen wij altijd de politie → Wij bellen altijd de politie.
- b''. Het is bij diefstal zo dat wij de politie helpen.  
 it is in.case.of theft the.case that we the police phone

That conditional phrases cannot be used as VP adverbials is due to the fact that they function as the antecedent P of a material implication  $P \rightarrow Q$  and not as a restrictor of Q: we can only conclude that proposition Q is true if proposition P is true as well. For the same reason we can conclude that the conditional clause in (100a) must function as a clause adverbial. Although this cannot be proved on the basis of the entailment test, we should probably conclude the same for its concessive counterpart in (100b). That these conditional and concessive clauses can be used as clause adverbials is evident from the fact illustrated in the primed examples that they pass the scope test.

- (100) a. Als het mooi weer is, gaan we naar de dierentuin.  
 if it nice weather is go we to the zoo  
 'If the weather is nice we will go to the zoo.'
- a'. Als het mooi weer is, is het zo dat we naar de dierentuin gaan.  
 if it nice weather is is it the.case that we to the zoo go

- b. Hoewel het regent, gaan we naar de dierentuin.  
 although it rains go we to the zoo  
 'Although it is raining we will go to the zoo.'
- b'. Hoewel het regent, is het zo dat we naar de dierentuin gaan.  
 although it rains is it the.case that we to the zoo go

### XI. Domain adverbials

Section 8.2.1, sub I, has shown that domain adverbials such as *juridisch* 'legally' in (101a) can be used as VP adverbials. The fact illustrated in (101b) that such adverbials sometimes precede the modal adverb *waarschijnlijk* 'probably' suggests that they can also be used as clause adverbials. The primed examples show that this is supported by the application of the entailment and scope tests.

- (101) a. Jan vecht zijn ontslag (waarschijnlijk) *juridisch* aan. [VP adverbial]  
 Jan fights his dismissal probably legally prt  
 'Jan (probably) contests his dismissal on legal grounds.'
- a'. Jan vecht zijn ontslag aan en hij doet dat *juridisch*.  
 Jan fights his dismissal prt. and he does that legally
- a''. Jan vecht zijn ontslag *juridisch* aan. → Jan vecht zijn ontslag aan.
- b. Jan heeft *juridisch* (waarschijnlijk) gelijk. [clause adverbial]  
 Jan has legally probably right  
 'Legally, Jan is (probably) right.'
- b'. Het is *juridisch* zo dat Jan gelijk heeft.  
 it is legally the.case that Jan right has
- b''. Jan heeft *juridisch* gelijk. ↗ Jan heeft gelijk.

The two uses of domain adverbials involve a different scope. VP adverbials restrict the denotation of the verbal projection; consequently, the particular choice of one of the domain adverbials in (102) will have far-reaching consequences for the goal, means and method used in performing the action of investigating adverbs.

- (102) Jan onderzoekt adverbia *syntactisch/morfologisch/semantisch*.  
 Jan investigates adverbs syntactically/morphologically/semantically  
 'Jan is investigating adverbs syntactically/morphologically/semantically.'

The clause adverbials, on the other hand, have scope over the complete proposition expressed by lexical domain of the clause and may affect the truth value of the clause: as is indicated by the invalidity of the entailment in (101b''), the fact that Jan is right from a legal point of view does not entail that he is right, since he might be wrong from, e.g., a moral point of view. Related to this difference is the fact that the clause (but not the VP) adverbials prototypically surface in the form of a phrase headed by the participle *gezien* 'seen', which embeds a domain adverbial functioning as a modifier of the participle; this is illustrated in (103).

- (103) a. Jan vecht zijn ontslag waarschijnlijk *juridisch* (\*gezien) aan.  
 Jan fights his dismissal probably legally seen prt  
 'Jan contests his dismissal on legal grounds.'
- b. Jan heeft *juridisch* (gezien) waarschijnlijk gelijk.  
 Jan has legally seen probably right  
 'Legally speaking, Jan is probably right.'



## XII. Conjunctive adverbials

Conjunctives are adverbial phrases relating the clause they modify to some state-of-affairs mentioned earlier in the discourse. Although conjunctives differ syntactically from conjunctions in that they are clausal constituents, Haeseryn et al. (1997: section 8.5) note that they perform a similar semantic function in that both of them specify various relations between utterances. Conjunctives may simply function as linkers, indicate contrast and various contingency relations between utterances, as indicated in (104): we omitted from these lists various obsolete forms provided by Haeseryn et al., as well as particles such as *ook* 'also', *zelfs* 'even', which were discussed in Subsection II as focus particles.

- (104) • Conjunctives
- a. Linking: *bovendien/daarenboven* 'moreover', *eveneens* 'also', *evenmin* 'neither', *tevens* 'also'
  - b. Contrast: *daarentegen* 'on the other hand', *desalniettemin/desondanks* 'nevertheless', *echter/evenwel* 'however', *integendeel* 'on the contrary', *niettemin* 'nevertheless', *nochtans* 'still', *toch* (with accent) 'just the same'
  - c. Contingency: *althans* 'at least', *bijgevolg* 'as a consequence', *derhalve* 'therefore', *dus* 'thus', *dientengevolge* 'consequently', *immers* 'after all', *overigens*, 'anyway', *trouwens* 'for that matter', *toch* (without accent)

That the adverbials in (104) are clause adverbials is clear from the fact that they satisfy the scope test in (58b), as is illustrated in (105).

- (105) a. Jan is een goed taalkundige. Hij is *bovendien* een goed schrijver.  
 Jan is a good linguist. he is moreover a good writer  
 'Jan is a good linguist. Moreover, he is a good writer.'
- a'. Het is *bovendien* zo dat hij een goed schrijver is.  
 it is moreover the.case that he a good writer is
  - b. Els heeft weinig tijd. Ze komt *desondanks* toch naar je lezing.  
 Els has little time she comes nevertheless prt to your talk  
 'Els is very busy. Nevertheless, she will attend your talk.'
  - b'. Het is *desondanks* zo dat ze naar je lezing komt.  
 it is nevertheless the.case that she to your talk comes
  - c. Marie is er niet. Ze is *immers* ziek.  
 Marie is there not she is after.all ill  
 'Marie is not present. She's ill, as you know.'
  - c'. Het is *immers* zo dat ze ziek is.  
 it is after.all the.case that she ill is

Note in passing that some of the conjunctives in (104) also easily occur clause-externally; *daarentegen* in (106a') is clearly used parenthetically, as is clear from the fact that it is preceded and followed by an intonation break; *trouwens* in (106b') is clearly clause-external, as it precedes the clause-initial position.



- (106) a. Marie is erg open. Jan is *daarentegen* terughoudend. [adverbial]  
 Marie is very candid. Jan is on.the.other.hand reserved
- a'. Marie is open. Jan, *daarentegen*, is terughoudend. [clause-external]  
 Marie is candid. Jan on.the.other.hand is reserved  
 'Marie is candid. Jan, on the other hand, is reserved.'
- b. Ik wil niet dansen. Ik heb *trouwens* geen tijd. [adverbial]  
 I want not dancing I have anyway no time
- b'. Ik wil niet dansen. *Trouwens*, ik heb geen tijd. [clause-external]  
 I want not dancing anyway, I have no time  
 'I do not want to dance. I don't have time, for that matter.'

### XIII. *Speech-act related adverbials*

Speech-act adverbials such as *eerlijk gezegd* 'honestly speaking' are normally phrasal and consist of a participle preceded by a manner adverb. They are always speaker-oriented and provide information about the performance of the speech act; by using the adverbial *eerlijk gezegd* in (107a), for instance, the speaker expresses that he gives his opinion straightforwardly despite the fact that he is aware of the fact that the addressee may feel uneasy about it. That speech-act adverbials are clause adverbials is clear from the fact that they easily pass the scope test, as is shown for *eerlijk gezegd* in (107b).

- (107) a. *Eerlijk gezegd* heb ik geen zin in dansen.  
 honestly said have I no liking in dance  
 'Honestly speaking, I don't feel like dancing.'
- b. Het is *eerlijk gezegd* zo dat ik geen zin in dansen heb.  
 it is honestly said the.case that I no liking in dancing have

Speech-act adverbials are placed high in the functional domain of clause; they are often the first adverbial in the clause. Furthermore, they also occur and, in fact, often feel more comfortable in clause-external position.

- (108) a. *Eerlijk gezegd*: ik heb geen zin in dansen.  
 honestly said I have no liking in dance  
 'Honestly speaking, I don't feel like dancing.'
- b. *Kort/ruwweg gezegd/samengevat*: Jan is ontslagen.  
 briefly/roughly said/summarized Jan is fired  
 'In short, Jan is fired.'
- c. *Vertrouwelijk gezegd*: hij wordt ontslagen.  
 confidentially said he is fired  
 'Confidentially, he will be fired.'

#### 8.2.3. *Multiple temporal/locational adverbials*

This section discusses the meaning contribution of spatio-temporal adverbial phrases in more detail. The basic observation is that clauses may contain more than one temporal or locational adverbial, as illustrated in the sentences in (109): the adverbials preceding the modal adverb (*gisteren/in Amsterdam*) function as clause adverbials while the ones following the modal (*om drie uur/bij zijn tante*) function as VP adverbials.

- (109) a. Jan is gisteren waarschijnlijk om drie uur vertrokken.  
 Jan is yesterday probably at 3 o'clock left  
 'Jan probably left at 3 o'clock yesterday.'
- b. Jan heeft in Amsterdam waarschijnlijk bij zijn tante gelogeed.  
 Jan has in Amsterdam probably with his aunt stayed  
 'Jan has probably stayed with his aunt in Amsterdam.'

This raises the question in what way the meaning contributions of these clause and VP adverbials differ. Our point of departure in answering this question will be binary tense theory: cf. Te Winkel (1866) and Verkuyl (2008). This theory was introduced in Section 1.5.1 and used in the description of the Dutch Tense system in Section 1.5.4. Although we will assume that the reader is familiar with these sections, we start in Subsection I by repeating some of the core findings. Subsection II subsequently discusses the semantic contribution of the two kinds of temporal adverbials: we will argue that VP adverbials are modifiers of eventualities, while clause adverbials modify the temporal domains that contain them. Subsection III will extend this proposal to locational adverbials.

*I. Theoretical background (Binary Tense Theory)*

Binary tense theory claims that the mental representation of tense is based on the three binary distinctions in (110). Languages differ when it comes to the means used for expressing these oppositions: this can be done within the verbal system by means of inflection and/or auxiliaries but it may also involve the use of adverbial phrases, aspectual markers, pragmatic information, etc.

- (110) a. [±PAST]: present versus past  
 b. [±POSTERIOR]: future versus non-future  
 c. [±PERFECT]: imperfect versus perfect

Verkuyl (2008) claims that Dutch expresses all the oppositions in (110) in the verbal system: [+PAST] is expressed by inflection, [+POSTERIOR] by the verb *zullen* 'will', and [+PERFECT] by the auxiliaries *hebben* 'to have' and *zijn* 'to be'. This leads to the eight-way distinction between tenses in Table 1 found in most Dutch grammars.

*Table 1: The Dutch tense system according to Verkuyl (2008)*

		PRESENT	PAST
SYNCHRONOUS	IMPERFECT	present <i>Ik wandel.</i> I walk	simple past <i>Ik wandelde.</i> I walked
	PERFECT	present perfect <i>Ik heb gewandeld.</i> I have walked	past perfect <i>Ik had gewandeld.</i> I had walked
POSTERIOR	IMPERFECT	future <i>Ik zal wandelen.</i> I will walk	future in the past <i>Ik zou wandelen.</i> I would walk
	PERFECT	future perfect <i>Ik zal hebben gewandeld.</i> I will have walked	future perfect in the past <i>Ik zou hebben gewandeld.</i> I would have walked

Sections 1.5.2 and 1.5.4 departed from Verkuyl’s original claim that *zullen* can be used as a future auxiliary and argued that it is an epistemic modal verb in all its uses—it is only due to pragmatic considerations that examples with *zullen* are sometimes interpreted with future time reference; cf. Broekhuis & Verkuyl (2014). If this is indeed correct, the Dutch verbal system only expresses the binary features  $[\pm\text{PAST}]$  and  $[\pm\text{PERFECT}]$ , and therefore does not make an eight-way but only a four-way tense distinction. This means that the traditional view on the Dutch verbal tense system in Table 1 should be replaced by the one in Table 2. Since the examples with *zullen* no longer define a separate set of future tenses, posteriority must be expressed by other means.

Table 2: *The Dutch verbal tense system (revised)*

	PRESENT	PAST
IMPERFECT	simple present <i>Ik wandel/Ik zal wandelen.</i> I walk/I will walk	simple past <i>Ik wandelde/Ik zou wandelen.</i> I walked/I would walk
PERFECT	present perfect <i>Ik heb gewandeld/</i> <i>Ik zal hebben gewandeld.</i> I have walked/I will have walked	past perfect <i>Ik had gewandeld/</i> <i>Ik zou hebben gewandeld.</i> I had walked/I would have walked

The revised view on the verbal tense system of Dutch implies that utterances in the simple present/past should in principle be able to refer to any subinterval within present/past-tense interval  $i$ . This is indicated in Figure 1, in which the dotted line indicates the time line, for various possible worlds in which simple present/past sentences like *Ik wandel* ‘I walk’ and *Ik wandelde* ‘I walked’ are predicted to be true; observe that the number of possible worlds is in principle infinite and that we simply made a selection that suits our purpose. World 1 depicts the situation in which eventuality  $k$  precedes speech time  $n$  or virtual speech-time-in-the-past  $n'$ , that is, the situation in which  $k$  is located in the actualized part  $i_a$  of present/past-tense interval  $i$ . World 3 depicts the situation in which  $k$  follows  $n/n'$ , that is, in which it is located in the non-actualized part  $i_\diamond$  of present/past-tense interval  $i$ . World 2, finally, depicts the situation in which  $k$  occurs at  $n/n'$ . We did not mention time interval  $j$  yet, but its function will become clear shortly.

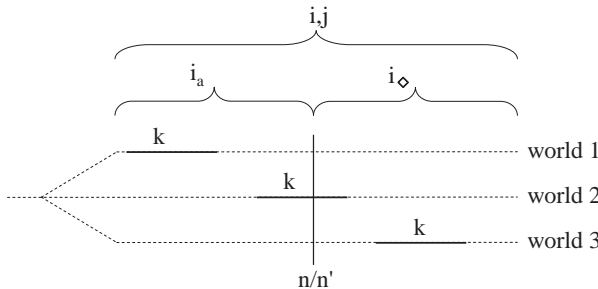

Figure 1: *Simple tenses in Dutch*

The representation of perfect tense examples like *Ik heb gewandeld* ‘I have walked’ and *Ik had gewandeld* ‘I had walked’ in Figure 2 is virtually identical to that in Figure 1; the only difference is that eventuality  $k$  is presented as a completed autonomous unit within present/past-tense interval  $i$ , as is indicated by the vertical line at the right-hand border of  $k$ .

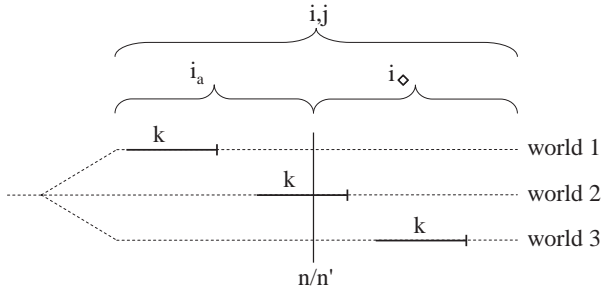

Figure 2: Perfect tenses in Dutch

The proposal outlined above overgenerates considerably. We predict, for instance, that any simple present sentence can refer to the situation depicted in world 1 in Figure 1, whereas we would generally use a present perfect to refer to such a situation. Section 1.5.4.1 has shown that the prediction is correct in the more specific situation depicted in Figure 1 in which the speaker has a knowledge gap about the state-of-affairs in the actual world prior to speech time  $n$  (indicated by the fact that the split-off point of the possible worlds precedes  $n$ ); example (111) can be used only if the speaker does not know whether Els has already finished reading.

- (111) Els leest vanmorgen mijn artikel.  
 Els reads this.morning my paper  
 ‘Els is reading my paper this morning.’

The reason for this is pragmatic in nature. If the speaker knows that eventuality  $k$  precedes  $n$ , he can present  $k$  as a discrete, bounded unit which has been completed within the actualized part time interval  $i_a$  of present-tense interval  $i$ : since this can be described more precisely by the present perfect, Grice’s °maxim of quantity prohibits the use of the less informative simple present. We refer the reader to 1.5.4.1, sub II, and 1.5.4.2, sub II, for a more detailed discussion.

Furthermore, it seems that simple present-tense clauses refer by default to the situation depicted in world 2 in Figure 1, while present perfect clauses refer by default to the situation depicted in world 1 in Figure 2; reference to the situations in the alternative worlds is possible but only if the context provides special clues that this is indeed what is intended by the speaker. The subsections below will show that temporal and locational adverbials play an important role in providing such clues. The discussion will pay special attention to how their status as clause or VP adverbial affects their meaning contribution. Subsection II starts by discussing the temporal adverbials; it adopts the hypothesis put forth in Sections 1.5.4.1, sub III, and 1.5.4.2, sub III, that while temporal VP adverbials modify eventuality  $k$  directly, temporal clause adverbials do so indirectly by modifying the so-called present  $j$  of  $k$ , that is, the subdomain of present/past-tense interval  $i$  within which  $k$  must be located and which is taken to be identical to  $i$  in the default case (as

indicated in the two figures above). Subsection III will show that something similar holds for locational adverbials.

*II. Temporal adverbials*

This subsection discusses the semantic contribution of the temporal adverbials to the meaning of the clause. We will adopt the standard assumption from Section 8.2.1 that VP adverbials are modifiers of the proposition expressed by the lexical projection of the verb. In terms of the tense representations in Figure 1 and Figure 2 this amounts to saying that VP adverbials are modifiers of an eventuality *k*. This is evidently correct for durational adverbials such as *drie uur (lang)* ‘for three hours’ in (112), which simply indicate the duration of *k*.

- (112) Jan heeft drie uur (lang) gezongen.  
 Jan has three hour long sung  
 ‘Jan has been singing for three hours.’

This is also correct for punctual adverbials such as *om 15.00 uur* ‘at 3 p.m.’ in (113), which locates the eventuality of Jan’s departure at 3 p.m. in the non-actualized part *i*<sub>◇</sub> of present-tense interval *i* (where the selection of *i*<sub>◇</sub> is due to the use of the simple present for the pragmatic reason discussed in Subsection I). The default interpretation of (113a) is that Jan will be leaving at 3 o’clock *today*, but it can easily be overridden by contextual factors; this is especially clear in example (113b) where the clause adverbial *morgen* ‘tomorrow’ is used to indicate that the departure of Jan will take place at 3 o’clock of the first day following speech time *n*. Note that we have added the modal adverb *waarschijnlijk* ‘probably’ in order to distinguish between VP and clause adverbials; here we will ignore its semantic distribution in our discussion for the sake of simplicity.

- (113) a. Jan vertrekt (waarschijnlijk) om 15.00 uur.  
 Jan leaves probably at 3:00 p.m.  
 ‘Jan will (probably) leave at 3:00 p.m.’
- b. Jan vertrekt morgen (waarschijnlijk) om 15.00 uur.  
 Jan leaves tomorrow probably at 3:00 p.m.  
 ‘Jan will (probably) leave at 3:00 p.m. tomorrow.’

The easiest way of accounting for the meaning contribution of the clause adverbial *morgen* ‘tomorrow’ in (113b) is by assuming that it modifies the present *j* of *k*: representation (114) shows that *j* is taken to be identical to *i* by default, but that the use of a temporal clause adverbial restricts *j* to a subdomain of *i*; for ease of representation we indicated the non-default interpretation of *j* (and *k*) by means of a prime.

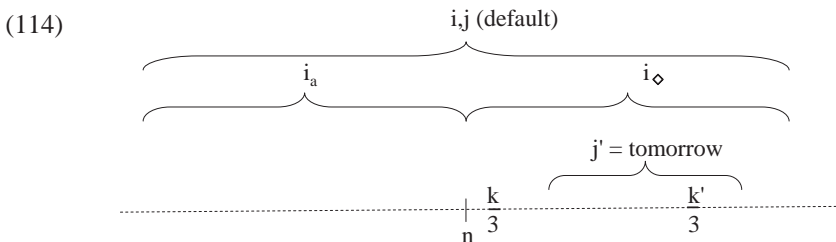

If we assume, as indicated in representation (114), that sentence (113a) is uttered at noon, its default interpretation would be derived as follows: the present  $j$  of  $k$  will be taken by default to be identical to the present-tense interval  $i$ . Since the simple present is again restricted to the non-actualized part  $i_\diamond$  of present-tense interval  $i$  for pragmatic reasons, the sentence refers to eventuality  $k$  as this is the first occasion after speech time  $n$  that fits the description *om 15.00 uur* (indicated by the numeral 3 in representation (114)). Note in passing that the sentence would refer to  $k'$  by default if it were uttered at 10.00 p.m., as this would be the first occasion after speech time  $n$  that fits the description *om 15.00 uur*. Representation (114) also shows that the default interpretation of (113a) is overridden in (113b) by the clause adverbial *morgen* ‘tomorrow’, which restricts the present of the eventuality to time interval  $j'$ : as a result, sentence (113b) can only refer to  $k'$ .

Now consider the present perfect examples in (115). If we assume that sentence (115a) is uttered in the evening, its default interpretation would be that eventuality  $k$  occurred earlier that day. The examples in (115b&c) show that this default reading can easily be overridden by adding a clause adverbial such as *gisteren* ‘yesterday’ or *morgen* ‘tomorrow’.

- (115) a. Jan is (waarschijnlijk) om 15.00 uur vertrokken.  
 Jan is probably at 3:00 p.m. left  
 ‘Jan (probably) left at 3:00 p.m.’  
 b. Jan is gisteren (waarschijnlijk) om 15.00 uur vertrokken.  
 Jan is yesterday probably at 3:00 p.m. left  
 ‘Jan (probably) left at 3:00 p.m. yesterday.’  
 c. Jan is morgen (waarschijnlijk) om 15.00 uur vertrokken.  
 Jan is tomorrow probably at 3:00 p.m. left  
 ‘Jan will (probably) have left at 3:00 p.m. tomorrow.’

The easiest way to account for the meaning contribution of the clause adverbials is again by assuming that clause adverbials modify the present  $j$  of  $k$ ; this is shown in representation (116), in which the various non-default interpretations of  $j$  and  $k$  are again indicated by means of primes.

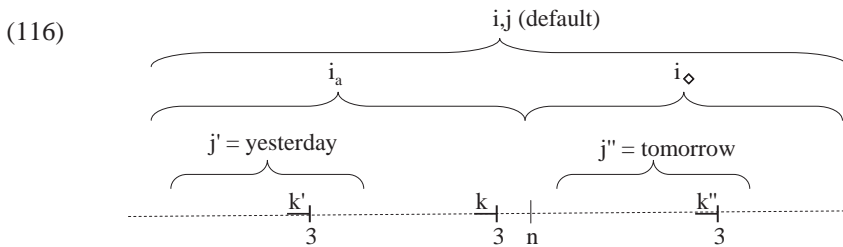

The default interpretation would be derived as follows. First, the present  $j$  of the eventuality will be taken to be identical to the present-tense interval  $i$ . Since Subsection I has shown that the present perfect is restricted to the actualized part  $i_a$  of the present-tense interval  $i$  for pragmatic reasons, the sentence refers to eventuality  $k$ , as this is the first occasion preceding speech time  $n$  that fits the description *om 15.00 uur*; note in passing that the sentence would refer to  $k'$  by

default, if it were uttered at 8.00 a.m., as that would then be the first occasion before speech time  $n$  that fits the description *om 15.00 uur*. The default interpretation of (115a) is overridden in (115b) by the clause adverbial *gisteren* ‘yesterday’, which restricts the present  $j$  to the time interval  $j'$ : as a result, sentence (115b) can only refer to  $k'$ . Similarly, the clause adverbial *morgen* ‘tomorrow’ in (115c) overrides the default interpretation of (115a) and restricts the present  $j$  to time interval  $j''$ : as a result, sentence (115c) can only refer to  $k''$ .

Representation (116) suggests that the VP adverbial *om 15.00 uur* locates the completion of the eventuality at 3 p.m. precisely. However, this is not what this adverbial actually does: it instead refers to a time at which the resulting state of eventuality  $k$  applies. This is clear from examples such as (117), based on Janssen (1983), in which the adverbial *al* indicates that the completion of the eventuality of Jan’s departure took place *before* 3 p.m. From this we may conclude that the interpretations indicated in representation (116) are default interpretations of the modified structures in (115b&c), which can again be overridden by adverbial modification (here: by *al*).

- (117) Jan is (waarschijnlijk) om 15.00 uur al vertrokken.  
 Jan is probably at 3:00 p.m. already left  
 ‘Jan will (probably) already have left at 3:00 p.m.’

The examples discussed so far have all been in the present tense, but the account can straightforwardly be applied to corresponding past tense cases as well (which will not be demonstrated here). We can conclude from this that the semantic interpretation of clauses with two temporal adverbials finds a natural accommodation and explanation in binary tense theory. This provides a strong argument in favor of the binary tense theory because Janssen (1983: fn.1) has shown that such cases are highly problematic for the Reichenbachian approach. Binary tense theory also accounts for the stringent word order restriction that applies to the two adverbials. First, consider the examples in (118), which show that the adverbials *morgen* ‘tomorrow’ and *om 15.00 uur* ‘at 3 o’clock’ can be used freely either as a VP adverbial or as a clause adverbial.

- (118) a. Jan gaat waarschijnlijk morgen/om 15.00 uur naar de bioscoop.  
 Jan goes probably tomorrow/at 3:00 p.m. to the cinema  
 ‘Jan will probably go to the cinema tomorrow/at 3:00 p.m.’  
 b. Jan gaat morgen/om 15.00 uur waarschijnlijk naar de bioscoop.  
 Jan goes tomorrow/at 3:00 p.m. probably to the cinema  
 ‘Jan will probably go to the cinema tomorrow/at 3:00 p.m.’

When the two adverbials co-occur in a single clause, however, there are severe restrictions on their distribution: the examples in (119) show that *morgen* ‘tomorrow’ must precede while *om 15.00 uur* must follow the modal adverb *waarschijnlijk* ‘probably’. Note in passing that we do not discuss cases such as *Jan gaat morgen om 15.00 uur waarschijnlijk naar de bioscoop*, in which the phrase *Morgen om 15.00 uur* constitutes a single clause adverbial, as is clear from the fact that it can be topicalized as a whole: *Morgen om 15.00 uur* gaat Jan waarschijnlijk naar de bioscoop.



- (119) a. Jan gaat morgen waarschijnlijk om 15.00 uur naar de bioscoop.  
 Jan goes tomorrow probably at 3:00 p.m. to the cinema  
 ‘Jan will probably go to the cinema at 3:00 p.m. tomorrow.’  
 b. <sup>§</sup>Jan gaat om 15.00 uur waarschijnlijk morgen naar de bioscoop.  
 Jan goes at 3:00 p.m. probably tomorrow to the cinema

The use of the dollar sign in (119b) indicates that the reason for the unacceptability of this example is not syntactic but semantic in nature: it is simply incoherent. Because *j* contains eventuality *k*, the modifier of *j* must refer to a time interval that contains the time (interval) indicated by the modifier of *k*. This is indeed the case in (119a), as *morgen* refers to a time interval that contains a point in time indicated by the adverbial *om 15.00 uur*, but this is not the case in (119b). For the same reason, an example such as (120) will only be felicitous if the addressee knows that there will be a meeting the next day; if not, the addressee will correct the speaker or ask him for more information about this meeting.

- (120) Jan geeft morgen waarschijnlijk een lezing na de vergadering.  
 Jan gives tomorrow probably a talk after the meeting  
 ‘Jan will probably give a talk after the meeting tomorrow.’

It is often difficult to pinpoint the precise semantic difference between the use of an adverbial as a VP adverbial or a clause adverbial. Consider the simple present examples in (121):

- (121) a. Jan gaat waarschijnlijk zaterdag dansen. [VP adverbial]  
 Jan goes probably Saturday dance  
 ‘Jan will probably go dancing on Saturday.’  
 b. Jan gaat zaterdag waarschijnlijk dansen. [clause adverbial]  
 Jan goes Saturday probably dance  
 ‘Jan will probably go dancing on Saturday.’

Many speakers judge these examples to be near-synonymous as they both refer to a dancing event on Saturday, but the semantic representations assigned to them under our current assumptions are quite different. In (121a), the present *j* of *k* is simply assigned the default reading according to which it is identical to present-tense interval *i*; eventuality *k* will be located in the non-actualized part *i*<sub>◊</sub> of this interval for pragmatic reasons and will therefore be situated at the first Saturday following speech time *n*; cf. representation (122a). The interpretation in (122b) is more indirect: first the present *j* of *k* is limited to the first Saturday in *i*<sub>◊</sub> and then eventuality *k* is located in this restricted time interval; cf. representation (122b). Note that the continuous line below *k* refers to the time interval referred to by *Saturday* in (122a) but to the duration of *k* in (122b).

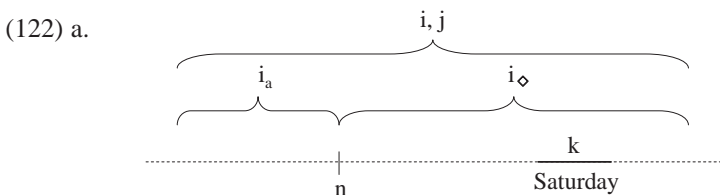



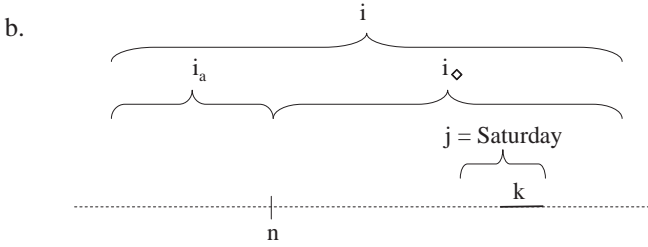

The meaning difference can be highlighted by means of the scope paraphrases that we have introduced for detecting clause adverbials. While (121a) can be paraphrased as *Het is waarschijnlijk zo dat Jan zaterdag gaat dansen* ‘It is probably the case that Jan will go dancing on Saturday’, example (121b) can be paraphrased as *Het is zaterdag waarschijnlijk zo dat Jan gaat dansen* ‘On Saturday, it is probably the case that Jan will go dancing’. The meaning difference becomes more conspicuous in examples such as (123) with the frequency adverb *altijd* ‘always’.

- (123) a. Jan gaat altijd op zaterdag dansen. [VP adverbial]  
 Jan goes always on Saturday dance  
 ‘Jan always goes dancing on a Saturday.’
- b. Jan gaat op zaterdag altijd dansen. [clause adverbial]  
 Jan goes on Saturday always dance  
 ‘Jan always goes dancing on Saturdays.’

Frequency adverbs such as *altijd* ‘always’ express that we are dealing with a re-occurring eventuality *k* in present/past-tense interval *i*. The VP adverbial *op zaterdag* ‘on a Saturday’ in (123a) provides more precise information about the locations of *k*; it indicates that *k* takes place on Saturdays only, as in representation (124a), in which *s* stands for *Saturday*. The clause adverbial *op zaterdag* ‘on Saturdays’ in (123b), on the other hand, indicates that it is an inherent property of Saturdays that *k* occurs; cf. (124b).

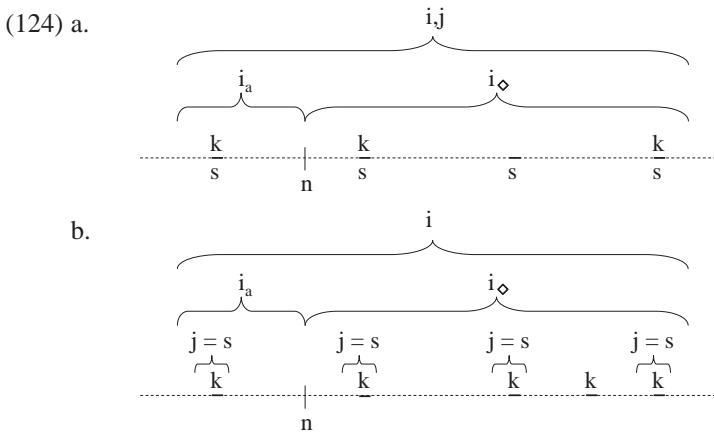

Representation (124a) also shows that it is not necessary that *k* occurs at every Saturday in order for (123a) to be true, while such a representation would make example (123b) false. Representation (124b) further shows that (123b) allows *k* to

occur on other days as well, while such a representation would make (123a) false. This suggests that the examples in fact express °material implications: example (123a) can be paraphrased by (125a), while (123b) can be paraphrased by (125b).

- (125) a. If Jan goes dancing, it is a Saturday.  
 b. If/Whenever it is a Saturday, Jan goes dancing.

This section has discussed a number of phenomena that receive a natural account within the binary tense approach. Since temporal modification in relation to tense theory is still a relatively unexplored domain, we have to leave it to future research to investigate to what extent binary tense theory can be exploited in this domain (although the reader may find some more information on this in Section 1.5.4). Subsection III will continue by showing that clauses with two locational adverbials may receive a similar account as clauses with two temporal adverbials.

### III. Locational adverbials

This subsection discusses the semantic contribution of locational adverbials to the meaning of the clause. We again adopt the standard assumption from Section 8.2.1 that VP adverbials are modifiers of the proposition expressed by the lexical projection of the verb. In terms of tense representations like those given in Figure 1 and Figure 2, this amounts to saying that VP adverbials are modifiers of eventuality  $k$ . This claim is evidently correct for example (126a), which simply locates the eventuality of Jan staying in some hotel. It is, however, less clear what the semantic contribution of the clause adverbial *in Amsterdam* in (126b) is.

- (126) a. Jan verblijft (waarschijnlijk) in een hotel.  
 Jan lodges probably in a hotel  
 ‘Jan is (probably) staying in a hotel.’  
 b. Jan verblijft in Amsterdam (waarschijnlijk) in een hotel.  
 Jan lodges in Amsterdam probably in a hotel  
 ‘Jan is (probably) staying in a hotel in Amsterdam.’

Assume that the sentences in (126) are used in a conversation about Jan, who is currently on a vacation. The default reading of example (126a) would then be that the eventuality of Jan staying in a hotel occurs at speech time  $n$ , as depicted in (127): the present  $j$  of  $k$  is taken to be identical to the present-tense interval  $i$  and  $k$  is taken to co-occur with speech time  $n$ .

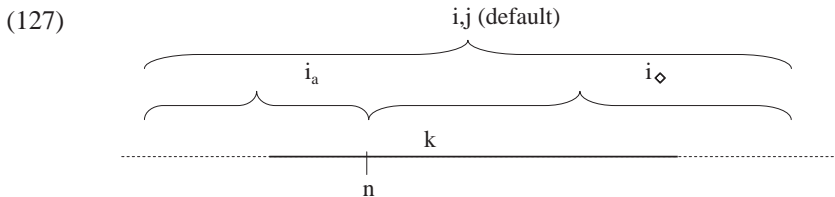

Example (126b) would instead express that the eventuality of Jan staying in a hotel is limited to the period in which he is visiting Amsterdam. This can be accounted for by assuming that the locational clause adverbial overrides the default interpretation in the same way as a temporal clause adverbial, namely by restricting the

present *j* of the eventuality. This is shown in representation (128), in which *k* is the eventuality of Jan being on holiday and *k'* is the eventuality of Jan staying in a hotel.

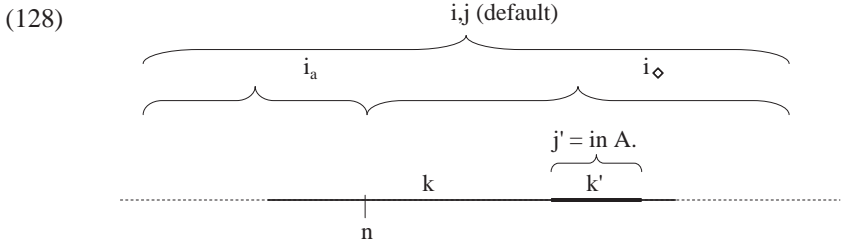

The discussion above has shown that locational and temporal adverbials are similar in that they modify the eventuality *k* when they are used as a VP adverbial, but the present *j* of *k* when they are used as clause adverbials. As in the case of temporal adverbials, the two uses of locational adverbials are not always easy to distinguish. Consider the examples in (129).

- (129) a. Jan gaat waarschijnlijk in Amsterdam dansen. [VP adverbial]  
 Jan goes probably in Amsterdam dance  
 ‘Jan will probably go dancing in Amsterdam.’
- b. Jan gaat in Amsterdam waarschijnlijk dansen. [clause adverbial]  
 Jan goes in Amsterdam probably dance  
 ‘Jan will probably go dancing in Amsterdam.’

Many speakers judge these examples to be near-synonymous as they both refer to a dancing event in Amsterdam, but the semantic representations assigned to them under our current assumptions are quite different. In (129a), the present *j* of *k* is simply assigned the default reading according to which it is identical to present-tense interval *i*. The eventuality *k* will be located in the non-actualized part *i<sub>◇</sub>* of this interval for pragmatic reasons; see representation (130a), which is essentially the same as (122a). The interpretation in (129b) is more indirect: first the present *j* of *k* is limited to the first occasion in *i<sub>◇</sub>* that Jan will be in Amsterdam and then eventuality *k* is located in this restricted time interval; cf. representation (130b), which is essentially the same as (122b).

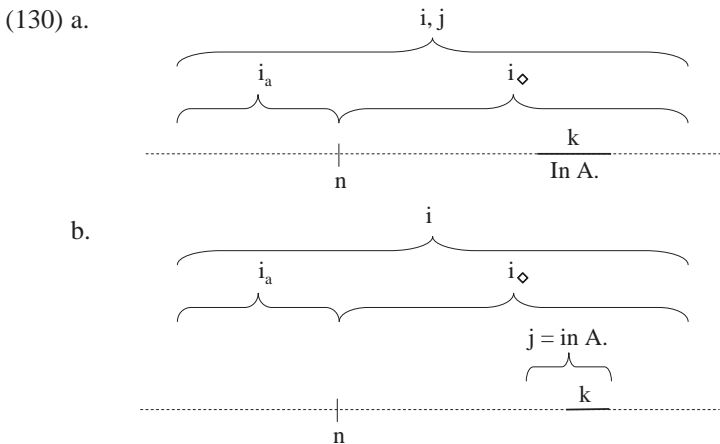

The meaning difference shows up in the scope paraphrases as well. While (129a) can be paraphrased as *Het is waarschijnlijk zo dat Jan in Amsterdam gaat dansen* ‘It is probably the case that Jan will go dancing in Amsterdam’, example (129b) can be paraphrased as *Het is in Amsterdam waarschijnlijk zo dat Jan gaat dansen* ‘In Amsterdam, it will probably be the case that Jan will go dancing’. The meaning difference again becomes more conspicuous in examples such as (131), with the frequency adverb *altijd* ‘always’.

- (131) a. Jan gaat altijd in Amsterdam dansen. [VP adverbial]  
 Jan goes always in Amsterdam dance  
 ‘Jan always goes dancing in Amsterdam.’  
 b. Jan gaat in Amsterdam altijd dansen. [clause adverbial]  
 Jan goes in Amsterdam always dance  
 ‘Jan always goes dancing in Amsterdam.’

The frequency adverb *altijd* is used to express that we are dealing with a re-occurring eventuality *k* in the present/past-tense interval *i*. The VP adverbial *in Amsterdam* (131a) provides more precise information about the location of *k*; it indicates that *k* takes place in Amsterdam only, as in representation (132a), in which *A* stands for *in Amsterdam*. The clause adverbial *in Amsterdam* in (131b), on the other hand, indicates that it is an inherent property of Jan’s visits to Amsterdam that *k* occurs; cf. (132b).

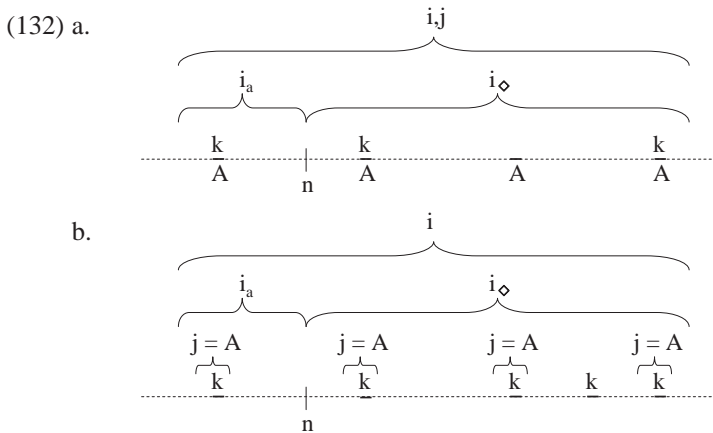

Representation (132a) also shows that it is not necessary that *k* occurs at every occasion that Jan is in Amsterdam in order for (131a) to be true, while such a representation would make example (131b) false. Representation (132b) further shows that (131b) allows *k* to occur on other days as well, while such a representation would make (131a) false. This suggests that the examples in fact express °material implications: example (131a) can be paraphrased by (133a), while (131b) can be paraphrased by (133b).

- (133) a. If Jan goes dancing, he is in Amsterdam.  
 b. If/Whenever Jan is in Amsterdam, he goes dancing.

The discussion above has shown that locational clause adverbials have more or less the same semantic impact as temporal clausal adverbs. Locational and temporal clause adverbials may also co-occur. The examples in (134a&b) are simply repeated from above and show that *op zaterdag* and *in Amsterdam* can both be used as clause adverbials; example (134c) shows that the two can also be combined. Such examples can be paraphrased as material implications with two conditions: (P & Q) → R: “if Jan is in Amsterdam and if it is Saturday, Jan goes dancing”.

- (134) a. Jan gaat op zaterdag altijd dansen.  
 Jan goes on Saturday always dance  
 ‘Jan always goes dancing on Saturdays.’
- b. Jan gaat in Amsterdam altijd dansen.  
 Jan goes in Amsterdam always dance  
 ‘Jan always goes dancing in Amsterdam.’
- c. Jan gaat in Amsterdam op zaterdag altijd dansen.  
 Jan goes in Amsterdam on Saturday always dance  
 ‘Jan always goes dancing in Amsterdam on Saturdays.’

#### IV. Conclusion

The previous subsections have shown that clauses with multiple temporal/locational adverbial phrases find a natural accommodation and explanation in binary tense theory: used as VP adverbials, they modify the eventuality expressed by the lexical domain of the clause; used as clause adverbials, they modify the present of this eventuality. We have noted that the difference between the resulting interpretations can be made more telling in the presence of the frequency adverb *altijd*; the interpretation can then be paraphrased by means of material implications, as illustrated by the example in (135), repeated from Subsection II.

- (135) a. Jan gaat altijd op zaterdag dansen. [VP adverbial]  
 Jan goes always on Saturday dance  
 ‘Jan always goes dancing on a Saturday.’
- a’. If Jan goes dancing, it is a Saturday.
- b. Jan gaat op zaterdag altijd dansen. [clause adverbial]  
 Jan goes on Saturday always dance  
 ‘Jan will probably go dancing on Saturdays.’
- b’. If it is a Saturday, Jan goes dancing.

In conclusion, note that a similar effect was found in Section A6.3.3 in the case of supplementives. This would suggest that our proposal concerning temporal and locational adverbials may be extended to other adverbials and adjuncts in general. Since this suggestion opens a new research program, we leave this issue for future research.

### 8.3. Categorial types of adverbial modifiers

It is generally recognized that adverbial phrases can be of various categorial types. They can be adjectival, prepositional, nominal, and may also take the form of a clause. We illustrate this in (136) by means of temporal adverbial phrases.

- (136) a. Jan gaat *erg vroeg* weg. [adjective phrase]  
 Jan goes very early away  
 'Jan is leaving quite early.'
- b. Jan gaat *voor zonsopgang* weg. [prepositional phrase]  
 Jan goes before sunrise away  
 'Jan is leaving before sunrise.'
- c. Jan gaat *volgende week* weg. [noun phrase]  
 Jan goes next week away  
 'Jan is leaving next week.'
- d. Jan gaat weg *voordat de zon op komt*. [clause]  
 Jan goes away before the sun up comes  
 'Jan is leaving before the sun rises.'

It is not the case, however, that all semantic types of adverbials can be realized in all four forms, and this section discusses the restrictions that we find. We start, however, by explaining why we do not distinguish a separate category of adverbs. After that, Sections 8.3.2 and 8.3.3 will deal with the constraints on the categorial realization of, respectively, VP and clause adverbials.

### 8.3.1. On the notion of adverb

There is little agreement in the literature on the question as to whether we should distinguish a separate category of adverbs. Proponents of the position that we should, e.g., Haeseryn et al. (1997:451) and Ernst (2002:8), define this presumed word class as consisting of lexical elements (and perhaps phrases) that can only function as adverbials. Nevertheless, it is customary for grammars to include elements in the set of adverbs that do not satisfy this criterion. Haeseryn et al. (1997:454), for instance, list the form *morgen* 'tomorrow' in examples such as (137a) as an adverb despite the fact that example (137b) shows that it can occur as the complement of a preposition. Because complements of prepositions are typically nominal, the examples in (137) should lead us to the conclusion that *morgen* is not an adverb but a noun.

- (137) a. Jan gaat *morgen* weg.  
 Jan goes tomorrow away  
 'Jan is leaving tomorrow.'
- b. Jan gaat pas *na morgen* weg.  
 Jan goes only after tomorrow away  
 'Jan will only be leaving after tomorrow.'

Another criterion that is sometimes used is that adverbs are invariant in form. This can be found in Haeseryn et al. (1997:451) but the same grammar simultaneously claims that certain adverbs such as the manner adverb *snel* 'fast' and the frequentative adverb *vaak* 'often' in (138) do allow comparative and superlative formation. Given this, there is no clear reason not to call these lexical items adjectives.

- (138) a. Jan wandelt snel/sneller.  
 Jan walks fast/faster  
 ‘Jan is walking fast/faster.’
- b. Jan komt vaak/vaker bij zijn moeder.  
 Jan comes often/more.often with his mother  
 ‘Jan visits his mother often/more often.’

Haeseryn et al. (1997:454) contrast “spurious” adverbs such as *snel* ‘quick’ and *vaak* ‘often’ in (138) with true adverbs, which are invariant in form. They illustrate these “true” adverbs by means of the locational elements *buiten* ‘outside’ and *hier* ‘here’ in (139a). However, the fact that the form of *buiten* is invariant also follows if we assume that it is actually a preposition, just as *buiten* in *Jan speelt graag buiten het gebouw* ‘Jan likes to play outside the building’. Furthermore, the fact that *hier* ‘here’ in example (139b) is invariant is due to the fact that we are dealing with a proform: in this respect, locational pro-forms simply behave like pronouns such as *hij* ‘he’ and *hem* ‘him’. That we should not consider the elements *buiten* and *hier* to be adverbs is also supported by the fact that they can also be used in other syntactic functions; this is illustrated in the primed examples in (139) by means of the verb *zetten* ‘to put’, which obligatorily selects a °complementive.

- (139) a. Jan speelt graag *buiten*.                    a'. Jan zet de bloemen buiten.  
 Jan plays gladly outside                    Jan puts the flowers outside  
 ‘Jan likes to play outside.’                    ‘Jan is putting the flowers outside.’
- b. Jan speelt *hier* graag.                    b'. Jan heeft de bloemen hier gezet.  
 Jan plays here gladly                    Jan has the flowers here put  
 ‘Jan likes to play here.’                    ‘Jan has put the flowers here.’

Since lexical items used as adverbial phrases have no characteristic morphological features either, there is hardly any reason for assuming a separate category of adverbs for Dutch; they can normally be analyzed as a noun, as *morgen* ‘tomorrow’ in (137a), an adjective, as *snel* ‘fast’ and *vaak* ‘often’ in (138), or a preposition, as *buiten* ‘outside’ in (139a), while many of the remaining cases are pro-forms. We therefore provisionally conclude that the category of adverbs does not exist (although we will keep using this notion for convenience); we refer the reader to Section N8.2, A8, and P1.2.4 for more relevant discussion. Nevertheless, the following two sections will occasionally point out forms for which it is not easy and perhaps even impossible to determine to what category they belong: the existence of these forms shows that the question as to whether we need a separate category of adverbs is still not fully answered.

### 8.3.2. VP adverbials

VP adverbials can be adjectival, prepositional, nominal or clausal, as was already illustrated for temporal adverbials in example (136) in the introduction to Section 8.3. It is not the case, however, that all semantic subtypes discussed in Section 8.2 are as versatile in this respect as temporal adverbials: the following subsections will discuss the restrictions on the manifestation of the various subtypes.

## I. Process Adverbials

Manner adverbials are prototypically APs, although example (140a) shows that it is sometimes also possible to realize them as PPs. The (b)-examples show that there are two proforms that can be used as manner adverbs: deictic *zo* ‘in this way’ and interrogative *hoe* ‘how’.

- (140) a. Jan heeft het hek *zorgvuldig/met veel zorg* geschilderd. [manner]  
 Jan has the gate carefully/with great care painted  
 ‘Jan has painted the gate carefully/with great care.’
- b. Met veel zorg, *zo* heeft hij het hek geschilderd. [deictic]  
 with great care so has he the gate painted  
 ‘With great care, in this way he has painted the gate.’
- b'. *Hoe* heeft hij het hek geschilderd? Met veel zorg. [interrogative]  
 how has he the gate painted with great care  
 ‘How has he painted the gate? With great care.’

Adverbials indicating instrument or means are prototypically realized as a *met*-PP, as in (141a), although Section 8.2.1, sub I, has shown that other prepositions are occasionally used as well. The (b)-examples in (141) show that the pronominal counterpart of these adverbials is normally a pronominal PP like deictic *daarmee* ‘with that’ or interrogative/relative *waarmee* ‘with what’, but it is also possible to use the interrogative proform *hoe* ‘how’. Deictic *zo* seems occasionally to be possible as well but this is clearly a marked option.

- (141) a. Jan heeft het gat *met een schep/zand* gevuld. [instrument/means]  
 Jan has the hole with a shovel/sand filled  
 ‘Jan has filled the hole with a shovel/sand.’
- b. Jan heeft het gat *daarmee* gevuld. [deictic]  
 Jan has the hole with.that filled  
 ‘Jan has filled the hole with that.’
- b'. *Waarmee/Hoe* heb je dat gat gevuld? Met een schep/zand. [interrogative]  
 with.what/how have you that hole filled with a shovel/sand  
 ‘With what/how have you filled that hole? With a shovel/sand.’

Volitional adverbials are again prototypically APs, although (142a) shows that they occasionally may surface as PPs as well. The (b)-examples show once more that deictic *zo* ‘in this way’ and interrogative *hoe* ‘how’ can be used as adverbial proforms.

- (142) a. Jan heeft zijn bekentenis *gedwongen/onder dwang* afgelegd. [volitional]  
 Jan has his confession forced/under pressure prt.-reported  
 ‘Jan has confessed under pressure.’
- b. Onder dwang, *zo* heeft Jan zijn bekentenis afgelegd. [deictic]  
 under pressure so has Jan his confession prt.-reported
- b'. *Hoe* heeft Jan zijn bekentenis afgelegd? Onder dwang. [interrogative]  
 how has Jan his confession prt.-reported under pressure



Domain adverbials such as *syntactisch* ‘syntactically’ in (143a) are APs. The (b)-examples show that deictic *zo* ‘in this way’ and interrogative *hoe* ‘how’ are used as adverbial proforms in this case.

- (143) a. Jan beschrijft de adverbia *syntactisch/morfologisch*. [domain]  
 Jan describes the adverbs syntactically/morphologically  
 ‘Jan is describing the adverbs syntactically/morphologically.’
- b. Syntactisch, *zo* beschrijft Jan de adverbia. [deictic]  
 syntactically so describes Jan the adverbs
- b’. *Hoe* beschrijft Jan de adverbia, syntactisch of morfologisch? [interrogative]  
 how describes Jan the adverbs syntactically or morphologically  
 ‘How does Jan describe the adverbs: syntactically or morphologically?’

This subsection has shown that process adverbials are normally adjectival or prepositional in nature. The adverbial proforms corresponding with the adjectival forms are deictic *zo* ‘in this way’ and interrogative *hoe* ‘how’. These proforms can generally also be used to refer to or to question process adverbials in the form of a PP, although *daarmee* ‘with that’ and *waarmee* ‘with what’ are clearly the preferred forms for adverbial *met*-PPs.

## II. Agentive adverbials

Agentive adverbials always have the form of a PP, such as the passive *door*-PP in (144a) or the comitative *met*-PP in (144b). There are no specialized proforms; pronominalization is done by replacing the nominal complement of the preposition by a pronoun.

- (144) a. Het pakket wordt *door Jan/hem* bezorgd. [agentive]  
 the parcel is by Jan/him delivered  
 ‘The parcel is delivered by Jan/him.’
- a’. *Door wie* wordt het pakket bezorgd?  
 by whom is the parcel delivered
- b. Jan heeft *met Els/haar* het museum bezocht. [comitative]  
 Jan has with Els/her the museum visited  
 ‘Jan has visited the museum with Els/her.’
- b’. *Met wie* heeft Els het museum bezocht?  
 with whom has Els the museum visited

## III. Spatio-temporal adverbials

Locational and temporal adverbials may take various forms: temporal adverbials especially are quite free in this respect. The possible manifestations of these adverbials will be discussed in separate subsections.

### A. Locational adverbials

Locational adverbial phrases are prototypically PPs. The prepositions in these adverbial phrases typically function as two-place predicates locating the event in a specific place. The adverbial phrase *in de tuin* ‘in the garden’ in (145a), for instance, expresses that event *e* of Jan playing takes place in the garden, while *onder de boom* ‘under the tree’ in (145b) expresses that it takes place under the tree;

this can be expressed in logical notation by, respectively, IN(e,garden) and UNDER(e,tree). We will not discuss here the various spatial relations expressible by prepositions, but refer the reader to Section P.1.3 for a detailed discussion of this. Observe that prepositional phrases like *buiten/binnen* ‘outside/inside’ and *boven/beneden* ‘upstairs/downstairs’ can be (pseudo-)intransitive and therefore surface as particles; we will not discuss this here but refer the reader to P1.2.4 for extensive discussion.

- (145) a. Jan heeft in the tuin gespeeld.  
 Jan has in the garden played  
 b. Jan heeft onder de boom gespeeld.  
 Jan has under the tree played

The proforms associated with place adverbials are typically °R-words: see P5.1 for discussion. All forms in (146) can be used to replace the adverbial PPs in (145). It should be noticed, however, that these forms are not specifically used as adverbials, but can also be used as °complementives; referring to these R-words as adverbs would therefore not do justice to their actual use.

- (146) a. Referential: *er* ‘there’  
 b. Demonstrative: *hier* ‘here’, *daar* ‘there’  
 c. Interrogative/relative: *waar* ‘where’  
 d. Quantificational: *overal* ‘everywhere’, *ergens* ‘somewhere’, *nergens* ‘nowhere’

A special proform-like element is the somewhat bookish form *elders* ‘elsewhere’, which is not part of the set of R-words. The fact that this form can also be used as the complement of a directional preposition such as *naar* suggests that it is actually nominal.

- (147) De piraat heeft de schat naar elders gebracht.  
 the pirate has the treasure to somewhere/else taken  
 ‘The pirate took the treasure to some other place.’

The R-words in (146) are also used in the formation of pronominal PPs, which can likewise be used as locational adverbials, so that we may find the two examples in (148) next to each other with virtually the same meaning. Again it would be wrong to call the pronominal PPs adverbs because they can also be used as complementives.

- (148) a. Jan heeft daar gespeeld. [daar = onder de boom]  
 Jan has there played  
 b. Jan heeft daaronder gespeeld. [daar = de boom]  
 Jan has under.it played

### B. Temporal adverbials (*punctual*)

Time adverbials are probably the most versatile adverbials when it comes to their categorial form. The examples in (149), repeated from the introduction to Section 8.3, show that they can be adjectival, prepositional, nominal or clausal. We will not

digress on these forms here as these are extensively discussed in Sections A8.2.1.4, P.1.3.2, N8.3.1, and P2.4.1.

- (149) a. Jan gaat erg vroeg weg. [adjective phrase]  
 Jan goes very early away  
 'Jan is leaving very early.'
- b. Jan gaat voor zonsopgang weg. [prepositional phrase]  
 Jan goes before sunrise away
- c. Jan gaat volgende week weg. [noun phrase]  
 Jan goes next week away
- d. Jan gaat weg voordat de zon opkomt. [clause]  
 Jan goes away before the sun prt.-rises

The examples in (150) show that the interrogative proform *wanneer* 'when' is used in questions, while *dat* is used in relative clauses; in the latter case, it is often also possible to use a pronominal PP.

- (150) a. Wanneer gaat Jan weg? [interrogative]  
 when goes Jan away  
 'When is Jan leaving?'
- b. Els denkt aan de tijd dat/waarin ze in Utrecht werkte. [relative]  
 Els thinks of the time that/where.in she in Utrecht worked  
 'Els is thinking of the time when she worked in Utrecht.'

There are various specialized deictic forms which locate eventuality *k* expressed by the clause with respect to some syntactically specified or contextually determined time, which we will loosely refer to as ANCHOR TIME *t*: (151) shows that *k* can be (virtually) simultaneous with *t*, or be anterior or posterior to it.

- (151) a. Simultaneous ( $k \approx t$ ): *direct* 'at once', *nu/nou* 'now', *onmiddellijk* 'immediately', etc.
- b. Anterior ( $k < t$ ): *net* 'only just', *pas* 'only just', *toen* 'then', *zoëven/zojuist* 'just now', *vroeger* 'in earlier times', etc.
- c. Posterior ( $k > t$ ): *aanstands* 'presently', *binnenkort* 'before long', *dadelijk* 'in a moment', *dan* 'then', *gauw* 'soon', *spoedig* 'soon', *straks* 'later', etc.

The discussion of the deictic forms in (151) takes as its point of departure the claim from binary tense theory that present-tense interval *i* includes speech time *n*, while past-tense interval *i* includes a virtual speech-time-in-the-past *n'*, where *n'* precedes *n*; cf. Section 1.5.1. Furthermore, the discussion encompasses the conclusion from Section 1.5.4 that the default interpretation of the present/past tense is that the so-called present *j* of eventuality *k* also includes *n/n'*, and that *k* is located at *n/n'* in the simple present/past while it precedes *n/n'* in the present/past perfect. That these default readings can be overridden by, e.g., adverbial modification shows that we are dealing with pragmatics, not semantics. The default readings can be observed most easily in the simple-present tense: without an indication to the contrary, (152a) is interpreted such that eventuality *k* of Jan reading the book occurs at *n*. This default reading is overridden by temporal

adverbials such as *morgen* ‘tomorrow’ in (152b), which locates *j* in a position following *n*, as a result of which eventuality *k* is also located after *n*.

- (152) a. dat Jan het boek leest. [default: *j* includes *n*]  
 that Jan the book reads  
 ‘that Jan is reading the book.’  
 b. dat Jan morgen (waarschijnlijk) het boek leest. [*j* follows *n*]  
 that Jan tomorrow probably the book reads  
 ‘that Jan will (probably) read the book tomorrow.’

Similar effects can be observed in the examples in the present-perfect tense in (153). Without an indication to the contrary, (153a) will be interpreted such that eventuality *k* of Jan reading the book was completed before *n* so that the resulting state of Jan having read the book occurs at *n*. Again, the temporal clause adverbial *morgen* ‘tomorrow’ overrides this default reading and locates the present *j* of *k* in a position following *n*; as a result, (153b) cannot be used to express that eventuality *k* was completed before *n* so that the resulting state can only occur after *n*. We refer the reader to Section 8.2.3 for a more detailed summary and further discussion.

- (153) a. dat Jan het boek heeft gelezen. [default: *j* precedes *n*]  
 that Jan the book has read  
 ‘that Jan has read the book.’  
 b. dat Jan morgen (waarschijnlijk) het boek heeft gelezen. [*j* follows *n*]  
 that Jan tomorrow probably the book has read  
 ‘that Jan (probably) will have read the book tomorrow.’

The mechanisms determining the default and non-default readings of the present/past tenses outlined above also play a role in the interpretation of the deictic adverbial forms in (151). We start by illustrating this for the forms in (151a), which express that eventuality *k* occurs more or less simultaneously with anchor time *t*. The default reading of the simple-present example in (154a) is that eventuality *k* occurs more or less simultaneously with speech time *n*. We therefore expect that its past tense counterpart in (154b) expresses that eventuality *k* occurs more or less simultaneously with virtual speech-time-in-the-past *n'*, but this is only partly borne out: while *direct* ‘directly’ and *onmiddellijk* ‘immediately’ indeed meet this expectation, *nu* ‘now’ does not. This contrast suggests that we should distinguish between tense-sensitive and speaker-oriented adverbials: while tense-sensitive adverbials like *direct* and *onmiddellijk* locate *k* relative to *n* or *n'* depending on the tense of the clause, the speaker-oriented adverbial *nu* always locates *k* relative to *n*.

- (154) a. Jan vertrekt *direct/onmiddellijk/nu*. [*k* occurs approximately at *n*]  
 Jan leaves at.once/immediately/now  
 ‘Jan is leaving at once/immediately/now.’  
 b. Jan vertrok *direct/onmiddellijk/\*nu*. [*k* occurs approximately at *n'*]  
 Jan left at.once/immediately/now  
 ‘Jan left at once/immediately.’

The readings of the examples in (154), according to which eventuality *k* is located approximately at *n/n'* are default readings, which can again be overridden by the

use of temporal adverbials that shift anchor time  $t$  to some position on the time axis other than  $n/n'$ . This is illustrated by the examples in (155), in which eventuality  $k$  expressed by the matrix clause is located at approximately the same position on the time axis as eventuality  $k'$  expressed by the adverbial clause: the events of Jan leaving and Marie entering occur more or less simultaneously. The interpretative effect of this is clearest in the present-tense example (155a): because Marie's entering follows  $n$ , Jan's leaving will also be located after  $n$ . As a result, the speaker-oriented adverbial *nu* 'now' also gives rise to an infelicitous result in (155a) unless, perhaps, the entering of Marie is expected to occur approximately at speech time  $n$ , too. From the resulting contrast between (154a) and (155a), we can conclude that the distribution of *nu* is not determined by past/present-tense marking as such but by the location of anchor time  $t$  on the time axis. Example (155b) illustrates essentially the same thing for the past tense.

- (155) a. Wanneer Marie binnenkomt, vertrekt Jan direct/onmiddellijk/\*nu.  
 when Marie inside.comes leaves Jan at.once/immediately/now  
 'When Marie enters, Jan will be leaving at once/immediately.'  
 b. Toen Marie binnenkwam, vertrok Jan direct/onmiddellijk/\*nu.  
 when Marie inside.came left Jan at.once/immediately/now  
 'When Marie entered, Jan left at once/immediately.'

Now consider the anterior adverbials in (151b), which express that eventuality  $k$  expressed by the clause is located before anchor time  $t$ :  $t$  is again taken by default as  $n/n'$  in simple-present/past tense clauses. The examples in (156) show that *net* 'only just' and *pas* 'only just' are clear cases of tense-sensitive adverbials: while  $k$  occurs immediately before  $n/n'$  in (156a), it is located before eventuality  $k'$  expressed by the adverbial clauses in the (b)-examples. The interpretative effect is again clearest in the present tense: because the event of Jan arriving follows  $n$  in (156b) the state of Jan being away is also located after  $n$ .

- (156) a. Peter is/was net weg. [k precedes n/n']  
 Peter is/was just away  
 'Peter has/had just left.'  
 b. Peter is net weg als Jan aankomt. [k precedes t]  
 Peter is just away when Jan prt.-arrives  
 'Peter has just left when Jan arrives.'  
 b'. Peter was net weg toen Jan binnen kwam. [k precedes t]  
 Peter was just away when Jan came in  
 'Peter had just left when Jan came in.'

The examples in (157) show again that we should make a distinction between tense-sensitive and speaker-oriented adverbials. Contrary to *net* in (156), the adverbials *zojuist* and *zoëven* in (157a) seem to be intrinsically anchored at speech time  $n$ : their interpretation is independent of the tense of the clause, as they simply locate eventuality  $k$  at some time just before  $n$ . That these adverbials cannot be used to locate  $k$  with respect to an anchor time other than  $n$  is clear from the fact illustrated in the (b)-examples that they cannot co-occur with adverbials introducing such an alternative anchor time  $t$ .

- (157) a. Jan is zojuist/zoëven vertrokken. [k precedes n]  
 Jan is just.now left  
 'Jan has just left.'
- b. Jan was zojuist/zoëven hier (\*toen Peter vertrok). [k precedes n]  
 Jan was just.now here when Peter left  
 'Jan was here just now.'
- b'. \*Jan is zojuist/zoëven hier (als Peter vertrekt). [k does not precede n]  
 Jan is just.now here when Peter leaves

That speaker-oriented adverbials cannot co-occur with adverbials introducing an anchor time other than *n* also accounts for the fact that *zojuist/zoëven* cannot occur in clauses in the simple present, as, for pragmatic reasons, such clauses do not allow *k* to be located in the actualized part of the present-tense interval. These adverbials thus behave like nominal modifiers such as *gisteren* 'yesterday' and *verleden week* 'last week'; this is illustrated in (158) for the speaker-oriented adverbial *toen* 'then'.

- (158) a. Jan was toen/gisteren/verleden week hier. [simple past]  
 Jan was then/yesterday/last week here  
 'Jan was here then/yesterday/last week.'
- b. \*Jan is toen/gisteren/verleden week hier. [simple present]  
 Jan is then/yesterday/last week here

The posterior adverbials in (151c) are even more restricted in that they all seem to be anchored by speech time *n*: it is very hard to find or even construct examples in which they occur in past-tense clauses. These adverbials thus behave essentially the same as nominal modifiers such as *morgen* 'tomorrow' and *volgende week* 'next week'.

- (159) a. Jan bezoekt Marie binnenkort/morgen/volgende week. [present tense]  
 Jan visits Marie soon/tomorrow/next week  
 'Jan will visit Marie soon/tomorrow/next week.'
- b. \*Jan bezocht Marie binnenkort/morgen/volgende week. [past tense]  
 Jan visited Marie soon/tomorrow/next week

Now that we have discussed the deictic adverbial forms in (151), we can continue with the discussion of the various specialized subordinators in (160) which are used to introduce temporal clauses. These subordinators can again be divided into three semantic groups by the way in which they locate eventuality *k* with respect to some anchor time *t*, that is, the time at which eventuality *k'* introduced by the adverbial clause occurs: *k* can be simultaneous with *t/k'*, or precede or follow it. We refer the reader to Section P2.4 for more information about the form of these subordinators.

- (160) a. Simultaneous ( $k \approx t$ ): *als/wanneer* 'when', *terwijl* 'while', *toen* 'when', *zolang* '(for) as long as', *nu* 'now (that)', *zodra/zo gauw (als)* 'as soon as'
- b. Anterior ( $k < t$ ): *alvorens* 'before', *eer(dat)* 'before', *tot(dat)* 'until', *voor(dat)* 'before'
- c. Posterior ( $k > t$ ): *na(dat)* 'after', *nu* 'now (that)', *zodra/zo gauw (als)* 'as soon as', *sinds/sedert* 'since', *toen* 'when'

There are usually no restrictions on tense marking: the examples in (161a&b) show that all types of conjunctions can be used in present-tense and past-tense clauses. The relevant factor is merely the chronological order of the eventualities expressed by the matrix and the embedded clause. This may also account for the phenomenon that main and adverbial clauses must agree in present/past tense marking (the so-called SEQUENCE-OF-TENSE effect). The unacceptability of the (c)-examples in (161) may follow immediately from binary tense theory; by using non-agreeing tenses, the eventualities expressed by the main and the embedded clause are part of different tense intervals (namely, one in the present-tense interval and one in the past-tense interval), and this may make it impossible to linearize them. Note in passing that the adverbial clauses introduced by *nadat* sound somewhat marked but become perfectly natural in the perfect tense (*nadat hij gedanst heeft/had* ‘after he has/had danced’).

- (161) a. Jan speelt viool terwijl/voordat/<sup>?</sup>nadat hij danst. [present tense]  
 Jan plays violin while/before/after he dances  
 ‘Jan plays the violin while/before/after he dances.’
- b. Jan speelde viool terwijl/voordat/<sup>?</sup>nadat hij danste. [past tense]  
 Jan played violin while/before/after he danced  
 ‘Jan played the violin while/before/after he danced.’
- c. \*Jan speelt viool terwijl/voordat/nadat hij danste. [no sequence-of-tense]  
 Jan plays violin while/before/after he danced
- c’. \*Jan speelde viool terwijl/voordat/nadat hij danst. [no sequence-of-tense]  
 Jan played violin while/before/after he dances

The (a)-examples in (162) show that adverbial clauses introduced by *toen* ‘when’ are exceptional in that they can occur in past tense sentences only. Since the adverbial *nu* ‘now’ can only be used in present-tense clauses, we may expect something similar for adverbial clauses introduced by *nu* but the (b)-examples show that this is not borne out (although we should perhaps point out that examples such as (162b’) are only fully felicitous in narratives).

- (162) a. Toen Marie vertrok, kwam Jan binnen. [past tense]  
 when Marie left came Jan inside  
 ‘When Marie left, Jan came in.’
- a’. \*Toen Marie vertrekt, komt Jan binnen. [present tense]  
 when Marie leaves comes Jan inside
- b. Nu hij afgestudeerd is, kan hij gaan werken. [present tense]  
 now.that he prt-graduated is can he go work  
 ‘Now that he has graduated, he can start working.’
- b’. Nu hij afgestudeerd was, kon hij gaan werken. [past tense]  
 now.that he prt-graduated was could he go work  
 ‘Now that he was graduated, he could start working.’

A number of temporal subordinators are listed as simultaneous as well as posterior in (160). Haeseryn et al. (1997: section 10.3.3) noted that the interpretation of these elements is determined by the temporal properties of the adverbial clause. The examples in (163) show that the simultaneous reading arises when the adverbial



clause is in simple present/past tense, while the posterior reading arises if the clause is in perfect tense.

- (163) a. Zodra/Toen zij Peter zag, liep Els weg. [simultaneous]  
 as.soon.as/when she Peter saw walked Els away  
 'As soon as/When she saw Peter, Els walked away.'
- a'. Zodra/Toen zij Peter gezien had, liep ze weg. [posterior]  
 as.soon.as/when she Peter seen had walked she away  
 'As soon as/When she had seen Peter, she walked away.'
- b. Nu Marie Plato leest, vindt ze lezen weer leuk. [simultaneous]  
 now Marie Plato reads finds she reading again fun  
 'Now that Marie reads Plato, she considers reading fun again.'
- b'. Nu Marie Plato gelezen heeft, vindt ze lezen weer leuk. [posterior]  
 now Marie Plato read has finds she reading again fun  
 'Now that Marie has read Plato, she considers reading fun again.'

### C. Temporal adverbials (durational and frequentative)

Durational adverbials can be nominal, adjectival or prepositional.

- (164) a. Jan heeft [<sub>NP</sub> de hele dag] gewerkt. [nominal]  
 Jan has the whole day worked  
 'Jan has worked all day.'
- b. Jan heeft [<sub>AP</sub> (drie uur) lang] gewerkt. [adjectival]  
 Jan has three hours long worked  
 'Jan has worked for three hours.'
- c. Jan heeft [<sub>PP</sub> gedurende de vergadering] geslapen. [prepositional]  
 Jan has during the meeting slept  
 'Jan has slept during the meeting.'

There are many forms expressing frequency: *nooit* 'never', *eens* 'one time', *soms* 'sometimes', *vaak* 'often', *meestal/doorgaans/telkens* 'generally', *altijd* 'always'. It is often difficult to determine the categorial status of these forms: we can only say for certain that *vaak* 'often' and *veel* 'a lot' are adjectives given that they can also occur in comparative and superlative form: *vaak* - *vaker* - *het vaakst*; *veel* - *meer* - *het meest*). Note in passing that it is not obvious that these forms can indeed be used as VP adverbials: because examples such as (165a) do not easily allow the PRONOUN *doet dat* + ADVERB paraphrase but do allow the scope paraphrase, we are probably dealing with clause adverbials.

- (165) a. Jan lacht vaak/soms.  
 Jan laughs often/sometimes  
 'Jan laughs often/sometimes.'
- b. Jan lacht en hij doet dat <sup>?</sup>vaak/\*soms.  
 Jan laughs and he does that often/sometimes
- b'. Het is vaak/soms zo dat Jan lacht.  
 it is often/sometimes the.case that Jan laughs

The examples in (166) show that there are clear cases in which nominal phrases are used as VP adverbials: these adverbials are normally formed by means of the noun



*keer/maal* ‘time(s)’ preceded by a cardinal numeral *n*. The examples in (166b&c) show that (166a) can easily be paraphrased by means of a *PRONOUN* *doet dat* + *ADVERB* clause, while it does not allow the scope paraphrase.

- (166) a. Jan belt (waarschijnlijk) drie keer.  
 Jan rings probably three times  
 ‘Jan (probably) rings three times.’
- b. Jan belt (waarschijnlijk) en hij doet dat drie keer.  
 Jan rings probably and he does that three times
- b’. Het is waarschijnlijk <\*drie keer> zo dat Jan <drie keer> belt.  
 it is probably three times the.case that Jan rings

#### IV. Contingency: cause, reason, purpose, result, concession

Contingency adverbials prototypically are clauses introduced by one of the subordinators in (167); some of the subordinators are morphologically complex and we refer the reader to Section P2.4.1 for more information about their formation.

- (167) a. Cause and reason: *omdat* ‘because’, *doordat* ‘because’, *aangezien* ‘since’  
 b. Purpose and result: *opdat* ‘so that’; *om* ‘in order to’, *zodat* ‘so that’  
 c. Concessive: *ondanks dat* ‘despite that’

Some concrete examples of adverbial contingency clauses are provided in (168). Contingency adverbials may also take the form of a PP: causes can be expressed by *door*-PPs, purposes/results by *voor*-PPs, reasons by *vanwege*-PPs, and concessions by *ondanks*-PPs. To avoid repetition, we refer the reader to Section 8.2.1, sub IV, for PP-examples.

- (168) a. De computer werkt niet *doordat de harde schijf vol is*. [cause]  
 the computer works not because the hard disc full is  
 ‘The computer doesn’t work because the hard disc is full.’
- b. Jan zingt *omdat hij vrolijk is*. [reason]  
 Jan sings because he merry is  
 ‘Jan is singing because he’s merry.’
- c. Jan ruimt zijn kamer op *zodat Els daar kan werken*. [purpose/result]  
 Jan clears his room prt. so.that Els there can work  
 ‘Jan is clearing up his room so that Els can work there.’
- d. Jan heeft de griep *ondanks dat hij ingeënt is*. [concession]  
 Jan has the flue despite that he prt.-vaccinated has.been  
 ‘Jan has the flue despite the fact that he has been vaccinated.’

Interrogative and deictic contingency adverbials generally have the form of a pronominalized PP: *waardoor/daardoor* ‘as a result of what/that’, *waarom/daarom* ‘for which/that reason’ *waartoe/daartoe* ‘to what/that purpose’, *waarvoor/daarvoor* ‘for which/that reason’. These forms may feel somewhat lexicalized, but their PP origin is still undeniable: this is especially clear in the case of causes, as these appear in the form of a regular PP if the cause is [+HUMAN] such as *door wie/hem* ‘by who/him’. Another fact illustrating this is that adverbials of concession do not appear in the form of a pronominalized PP due to the fact that *ondanks* ‘in spite of’

never allows R-pronominalization; the interrogative form is *ondanks wat* ‘in spite of what’, while the deictic form is the lexicalized form *desondanks* ‘in spite of that’.

V. *Predicate-degree*: *erg* ‘very’; *een beetje* ‘a bit’

We can be brief on predicate-degree adverbials because Section 8.2.1, sub V, has already shown that a subset of the degree adverbs may also be used to modify verbal predicates: prototypical cases are *erg* ‘very’ and *een beetje* ‘a bit’. Occasionally, degree adverbials may also occur in the form of a clause. These cases are all idiomatic, as can be seen in (169): the first two examples have a resultative ring about them, while the third is clearly based on a metaphor. For detailed discussion of degree modifiers we refer the reader to Klein (1997).

- (169) a. Hij liegt *dat hij barst*.  
 he lies that he cracks  
 ‘He lies till he is black in the face.’
- b. Het regent *dat het giet*.  
 it rains that it pours  
 ‘It’s raining cats and dogs.’
- c. Hij liegt *alsof het gedrukt staat*.  
 he lies as.if it printed is  
 ‘He lies till he is black in the face.’

### 8.3.3. *Clause adverbials*

Section 8.3.2 has shown that most VP adverbials can surface in various forms: they can generally appear in an adjectival or prepositional form, and in some cases they can even be nominal or clausal. Since VP adverbials are typically phrasal, they can be formed productively. This also holds true for locational, temporal and contingency clause adverbials: they do not differ in essential ways from their counterparts functioning as VP adverbials. However, many clause adverbs are quite restricted when it comes to form, as is clear from the fact that in many cases they constitute a closed class of lexical elements, and it is therefore not surprising that precisely these elements are often considered to belong to a category of adverbs. Consider again the subclasses of clause adverbials in (170), taken from Section 8.2.2.

- (170) a. Polarity: negation (*niet* ‘not’); affirmation (*wel*)  
 b. Focus particles: *alleen* ‘only’, *ook* ‘too’, *zelfs* ‘even’, etc.  
 c. Aspectual: habitual; iterative; frequentative; continuative; etc.  
 d. Clause-degree (*bijna* ‘nearly’; *amper* ‘hardly’, etc.)  
 e. Propositional modal (*waarschijnlijk* ‘probably’; *blijkbaar* ‘apparently’)  
 f. Subject-oriented (*stom genoeg* ‘stupidly’, *wijselijk* ‘wisely’, etc.)  
 g. Subjective: factive (*helaas* ‘unfortunately’); non-factive  
 h. Point-of-view (*volgens Els* ‘according to Els’)  
 i. Spatio-temporal: place; time  
 j. Contingency: cause; reason; condition; concession  
 k. Domain (*juridisch gezien* ‘legally’, *moreel gezien* ‘morally’, etc.)  
 l. Conjunctive (*echter* ‘however’, *derhalve* ‘therefore’, etc.)  
 m. Speech-act related (*eerlijk gezegd* ‘honestly’, etc.)

POLARITY adverbials clearly constitute a closed class; it only contains the negative element *niet* ‘not’ and the affirmative element *wel*. These are normally considered adverbs, as it is not so easy to find decisive arguments to place them into one of the four major lexical categories. The same holds for the FOCUS PARTICLES in (170b): they constitute a relatively small set, and again it is difficult, if not impossible, to show that they belong to one of the major lexical categories. The categorial status of some of the ASPECTUAL adverbs is not difficult to detect: habitual *gewoonlijk* ‘usually’ and frequentative *vaak* ‘often’ are clearly adjectival, while *drie maal* ‘three times’ is clearly nominal. However, there are also many cases for which the category is less easy to determine; specific examples are continuative *nog* (*steeds*) ‘still’, terminative *niet meer* ‘no longer’, iterative *weer* ‘again’, and *al* ‘already’.

CLAUSE-DEGREE adverbials again constitute a more or less closed class: *bijna* ‘nearly’, *amper* ‘hardly’, *haast* ‘nearly’. Some of these elements can also be used as degree modifiers of adjectives but it is again difficult to determine whether they belong to one of the major lexical classes. This is easier for adverbials expressing PROPOSITIONAL MODALITY, which are recognizable as adjectives because of their morphological form in many cases: they are often derived by suffixes like *-(e)lijk* and *-baar*, and can sometimes be preceded by the negative prefix *on-*.

- (171) a. Epistemic adverbials: *gegarandeerd* ‘certainly’, *misschien* ‘maybe’, *mogelijk* ‘possibly’, *natuurlijk* ‘naturally/of course’, *noodzakelijk(erwijs)* ‘necessarily’, *ongetwijfeld* ‘undoubtedly’, *vermoedelijk* ‘supposedly’, *waarschijnlijk* ‘probably’, *zeker* ‘certainly’, etc.  
 b. Evidential adverbials: *blijkbaar* ‘evidently’, *duidelijk* ‘clearly’, *evident* ‘evidently’, *kennelijk* ‘obviously’, *klaarblijkelijk* ‘apparently’, *ogenschijnlijk* ‘apparently’, *onmistakbaar* ‘unmistakably’, *schijnbaar* ‘seemingly’, *vermoedelijk* ‘probably’, *zichtbaar* ‘visibly/evidently’, etc.

It should be noted, however, that the adjectives in (171) often exhibit restricted behavior when they are used adverbially. For instance, the examples in (172) show that while it is easily possible to question *waarschijnlijk* if used as complementive, this is not possible when it is used adverbially. It does not seem to be the case that this restriction is syntactic in nature, however: modal adverbials are often considered speaker-oriented in the sense that they provide the speaker’s evaluation, and it is therefore not likely that the speaker will question such a modal.

- (172) a. Dit is zeer waarschijnlijk.                      a'. Hoe waarschijnlijk is dit?  
           this is very likely                                      how likely is this  
 b. Jan gaat zeer waarschijnlijk weg.            b'. \*Hoe waarschijnlijk gaat Jan weg?  
           Jan goes very probably away            how probably goes Jan away  
           ‘Jan is quite probably leaving.’

It is less easy to explain that the adverbially used adjectives exhibit restrictions on modification that are not found in their attributively/predicatively used counterparts. For instance, while the primeless examples in (172) show that *waarschijnlijk* can be modified by the intensifier *zeer* ‘very’ regardless of its syntactic function, the intensifier *erg* ‘very’ or the downtoner *vrij* ‘fairly’ in the (a)-examples in (173) give rise to marked results when *waarschijnlijk* is adverbial. The (b)-examples show that

similar observations can be made with respect to comparative formation. The (c)-examples show that the adverbially used adjective is also more restricted than its attributively/predicatively used counterpart in that it does not allow *on-* prefixation.

- (173) a. Dit is erg/vrij waarschijnlijk.  
 this is very/fairly probable  
 a'. Jan gaat <sup>??</sup>erg/vrij waarschijnlijk weg.  
 Jan goes very/fairly probably away  
 b. Dit is waarschijnlijker (dan dat).  
 this is more.probable than that  
 b'. \*Jan gaat waarschijnlijker weg (dan Peter).  
 Jan goes more.probably away than Peter  
 c. Dit is onwaarschijnlijk.  
 this is improbable  
 c'. \*Jan gaat onwaarschijnlijk weg.  
 Jan goes improbably away

A special case worth mentioning in passing is *soms*, which is normally used as a frequency adverbial but also occurs as an epistemic modal in questions.

- (174) Bent u *soms* ziek?  
 are you perhaps ill  
 'Are you ill, perhaps?'

SUBJECT-ORIENTED adverbials are clearly adjectival, but are nevertheless severely restricted in form: they are normally followed by the modifying element *genoeg* 'enough', formed by the unproductive deadjectival suffix *-elijk*, or involve other less productive formations like *domweg* 'stupidly' and *botweg* 'bluntly/rudely'; see Diepeveen (2012) for relevant discussion of these deadjectival forms (as well as some of the other complex adverbial forms mentioned later in this section).

- (175) a. Jan ging *dom* (\**genoeg*) niet naar het feest.  
 Jan went stupid enough not to the party  
 'Jan stupidly didn't go to the party.'  
 b. Jan ging *wijselijk*/<sup>??</sup>*wijs* niet naar het feest.  
 Jan went wisely/wise not to the party  
 'Jan wisely didn't go to the party.'

SUBJECTIVE adverbials are probably also adjectival in nature, as is clear from the fact that *gelukkig* 'fortunately' and *vanzelfsprekend* 'obviously/self-evidently' are run-of-the-mill adjectives. This stance is further supported by the fact that these adverbials are sometimes modified by the element *genoeg* or formed by means of the deadjectival suffixes *-erwijs* and *-lijk*: cf. *jammer genoeg* 'regrettably', *begrijpelijk(er)wijs* 'understandably', and *hopelijk* 'hopefully'. It is, however, difficult to demonstrate this for the form *helaas* 'unfortunately'. Note that these adverbials are speaker-oriented in that they provided the speaker's evaluation, and it is therefore understandable that these adverbials cannot be questioned.

POINT-OF-VIEW adverbials are prototypically PPs headed by *volgens* ‘according to’; other cases are the PP *naar mijn mening* ‘in my opinion’ and the formulaic case-marked form *mijns inziens* ‘in my view’. We can also be brief about the SPATIO-TEMPORAL clause adverbials as they exhibit the same freedom in form as their counterparts functioning as VP adverbials; we can therefore refer the reader to the discussion in Section 8.3.2, sub III. More or less the same holds for the CONTINGENCY adverbials; we only have to add to the discussion in Section 8.3.2, sub IV, that conditional adverbials are typically expressed by a clause introduced by a subordinator such as *indien* ‘in the event of’, *mits* ‘provided that’, or *tenzij* ‘unless’. Note in passing that conditional clauses introduced by *mits/tenzij* can only be used in the right periphery of the clause. Occasionally, we also find (deictic) conditional PPs: cf. *Onder deze voorwaarde mag hij komen* ‘He may come on this condition’.

- (176) a. *Indien hij wil komen, moet hij me opbellen.*  
 if he wants come must he me prt.-call  
 ‘If he wants to come, he should call me.’  
 b. *Hij mag komen mits hij het me tijdig zegt.*  
 he may come provided he it me in.time tells  
 ‘He can come provided he tells me in time.’

The prototypical case of a conditional clause is probably a clause introduced by *als* ‘if’. It should be noted, however, that there is reason to believe that such conditional clauses are at least sometimes in extra-sentential position and should therefore not be analyzed as adverbials. This is quite clear from (177a), in which the first position of the main clause is filled by the resumptive proform *dan* ‘then’. Example (177b) further shows that such conditional clauses are special in that they alternate with V1-clauses; we will not digress on this point here but refer the reader to Section 10.3.2 for an extensive discussion of examples such as (177) as well as various related constructions.

- (177) a. *Als het morgen regent, dan ga ik naar de bioscoop.*  
 if it tomorrow rains then go I to the cinema  
 ‘If it rains tomorrow, I’ll go to the cinema.’  
 b. *Regent het morgen, dan ga ik naar de bioscoop.*  
 rains it tomorrow then go I to the cinema  
 ‘If it rains tomorrow, I’ll go to the cinema.’

Section 8.2.2, sub XI, has already shown that DOMAIN adverbials are normally adjectival, although it is also quite common to use phrases headed by a past/passive participle. This is illustrated again in (178).

- (178) a. *Theoretisch (gezien) is dat inderdaad te verwachten.*  
 theoretically seen is that indeed to expect  
 ‘Theoretically (seen), that is indeed to be expected.’  
 b. *Juridisch (gesproken) heeft hij gelijk.*  
 legally spoken has he correct  
 ‘Legally (speaking), he’s right.’

SPEECH-ACT RELATED adverbials such as *eerlijk gezegd* ‘honestly’ are generally expressed by a phrase consisting of a participle verb modified by a manner adverb; omission of the past/passive participle will give rise to an unacceptable result.

- (179) Eerlijk (\*gezegd) begrijp ik dat niet.  
 honestly said understand I that not  
 ‘Honestly speaking, I don’t understand it.’

Finally, CONJUNCTIVE adverbials like *echter* ‘however’ and *derhalve* ‘therefore’ again seem to make up a more or less closed set of elements; see Section 8.2.2, sub XII, for a representative sample of such adverbials.

This subsection has provided a brief review of the restrictions on the form of clause adverbials; we have shown that with the exception of the spatio-temporal and contingency adverbials, clause adverbials exhibit less variation in form than VP adverbials. Furthermore, clause adverbials seem to be subject to various idiosyncratic restrictions and tend to be part of lexically closed classes, which has motivated earlier claims in the literature that a separate category of adverbs should be recognized; see Section 8.3.1 for discussion.

#### 8.4. The unmarked order of adverbial modifiers

This section discusses the unmarked order of adverbial phrases. Establishing this order is not an easy task since the placement of adverbials exhibits a certain amount of freedom; adverbials are like most clausal constituents in that they may undergo various kinds of movement. Subsection I reviews a number of movement processes that may affect the surface order of adverbials, so as to restrict the discussion in such a way that we eliminate their interference as much as possible. Because it is relatively uncontroversial that VP adverbials follow clause adverbials in the unmarked order, we will be able to split our investigation into two parts: Subsections II and III discuss the unmarked word order of various subtypes of VP adverbials and clause adverbials, respectively. For want of sufficiently detailed research, the results in this section should be seen as preliminary, as will also be clear from the fact that we will have to leave various questions open for the moment.

##### *I. Movement operations affecting adverbials*

This subsection will show that adverbials can undergo various kinds of movement, which complicates our investigation of the unmarked word order of adverbials considerably. We can curb the interference of movement, however, by investigating the order of adverbials in the °middle field of the clause only, thus eliminating the effects of *wh*-movement and extraposition discussed in Subsections A and B. This reduction leaves us with movement operations affecting the word order in the middle field, such as focus movement and weak proform shift; these movement operations will be briefly addressed in Subsections C and D.

##### *A. Wh-movement (wh-question formation and topicalization)*

Most adverbials are like other clausal constituents in that they can be moved into clause-initial position under certain conditions. This holds especially for adverbial phrases that can be questioned, as shown in (180) for three kinds of VP adverbials.

- (180) a. Hoe heb je geslapen? Erg goed! [manner]  
 how have you slept very well  
 'How did you sleep? Very well!'
- b. Waarmee heb je dat gat gevuld? Met zand. [means]  
 with.what have you that hole filled with sand  
 'With what have you filled that hole? With sand.'
- c. Met wie heb je gedanst? Met Jan. [comitative]  
 with who have you danced with Jan  
 'Who have you danced with? With Jan.'

It will be clear that this sort of movement may affect the relative word order of adverbials when more than one adverbial phrase is present. This is illustrated in (181) for temporal and comitative adverbials; although we will see that there is reason for assuming that temporal adverbials precede comitative adverbials in the unmarked order, *wh*-movement can easily reverse this order.

- (181) a. Jan heeft gisteren met Peter/'m gedanst.  
 Jan has yesterday with Peter/him danced  
 'Jan danced with Peter/him yesterday.'
- b. Met wie heeft Jan gisteren gedanst?  
 with whom has Jan yesterday danced  
 'With whom did Jan dance yesterday?'

Many adverbials that cannot be questioned can still be placed in sentence-initial position by topicalization. This holds, e.g., for modal adverbs; although Section 8.3.3 has shown that they cannot be questioned, the examples in (182) show that topicalization can change the unmarked order of the temporal clause adverbial *morgen* 'tomorrow' and the adverb *waarschijnlijk* 'probably'.

- (182) a. Jan gaat morgen waarschijnlijk al om drie uur weg.  
 Jan goes tomorrow probably already at 3 o'clock away  
 'Jan will probably leave tomorrow at three o'clock already.'
- b. Waarschijnlijk gaat Jan morgen al om drie uur weg.  
 probably goes Jan tomorrow already at 3 o'clock away

Note in passing that there are additional restrictions on *wh*-movement; the examples in (183) show, for instance, that while temporal VP adverbials may cross temporal clause adverbials in questions, this is more difficult in topicalization constructions. Since this kind of intervention effect has not been studied in detail, we leave the issue to future research.

- (183) a. Hoe laat gaat Jan morgen weg? Om drie uur.  
 how late goes Jan tomorrow away at 3 o'clock  
 'When will Jan leave tomorrow? At 3 o'clock.'
- b. ??Om drie uur gaat Jan morgen weg.  
 at 3 o'clock goes Jan tomorrow away

For our present purpose, it suffices to say that the effects of *wh*-movement can be easily eliminated by restricting our attention to the relative order of adverbials in



the middle field of the clause; for a detailed discussion of *wh*-movement, we refer the reader to Section 11.3.

### B. Extraposition

Another way of affecting the unmarked order of adverbials is by extraposition, which is especially common for adverbials of the category PP or clause. We will see later that there are grounds for assuming that contingency adverbials such as *vanwege het mooie weer* ‘because of the nice weather’ in (184a) precede comitative adverbials such as *met Els* ‘with Els’ in the unmarked order. Nevertheless, extraposition of the contingency adverbial can easily reverse this order, as shown in (184b). In fact, (184c) shows that simultaneous extraposition of the two adverbials also requires the order to be inverted, a phenomenon that has become known as the MIRROR EFFECT; cf. Koster (1974).

- (184) a. Jan is vanwege het mooie weer met Els gaan wandelen.  
 Jan is because.of the nice weather with Els go walk  
 ‘Jan has gone walking with Els because of the nice weather.’
- b. Jan is met Els gaan wandelen vanwege het mooie weer.  
 Jan is with Els go walk because.of the nice weather
- c. Jan is gaan wandelen met Els vanwege het mooie weer.  
 Jan is go walk with Els because.of the nice weather

For our present goal, it again suffices to say that the interference of extraposition can be easily eliminated by restricting our attention to the relative order of adverbials in the middle field of the clause; for a detailed discussion of extraposition including the mirror effect, we refer the reader to Chapter 12.

### C. Focus movement

Even if we restrict our investigation to the middle field of the clause, we still have to deal with movement operations affecting the word order in this domain of the clause. One such movement operation is focus movement, which may move a contrastively focused phrase into a position preceding the negative clause adverb *niet* ‘not’. This is illustrated in (185), where focus accent is indicated by small caps.

- (185) a. Jan heeft niet met Marie gedanst.  
 Jan has not with Marie danced  
 ‘Jan hasn’t danced with Marie.’
- b. Jan heeft met MARIE niet gedanst (maar wel met ELS).  
 Jan has with Marie not danced but AFF with Els  
 ‘Jan hasn’t danced with MARIE (but he has with ELS).’

One way of excluding focus movement is by restricting our investigation to sentences with a neutral (non-contrastive) intonation pattern. With prepositional adverbial phrases it is often possible to exclude focus movement by using a weak pronoun as the complement of the preposition (or, alternatively, the weak pronominal PP *ermee* ‘with it’), as is illustrated in (186). For more information about focus movement, we refer the reader to Section 13.3.2.



- (186) Jan heeft <\*met 'r> niet <met 'r> gedanst.  
 Jan has with her not danced  
 'Jan hasn't danced with her.'

#### D. Weak proform shift

Weak proforms strongly prefer placement in the left periphery of the middle field of the clause, regardless of their syntactic function. That this also holds for adverbial phrases is illustrated by means of the locational adverbs in (187): while placing the adverbial PP *in Leiden* in a position preceding the modal adverb *waarschijnlijk* 'probably' leads to a severely degraded result, the corresponding weak locational proform *er* must precede it.

- (187) a. Jan woont <\*, in Leiden> waarschijnlijk al jaren <in Leiden>.  
 Jan lives in Leiden probably already years  
 'Jan has probably been living in Leiden for years.'  
 b. Jan woont <er> waarschijnlijk <\*er> al jaren.  
 Jan lives there probably already years  
 'Jan has probably lived there for years.'

For our present purpose, it suffices to say that the effect of weak proform shift can be eliminated by simply excluding weak proforms from our investigation; for more discussion of weak proform shift, we refer the reader to Section 13.4.

#### E. Conclusion

This subsection has shown that the investigation of the unmarked order of adverbials is complicated by the fact that most adverbials are like other clausal constituents in that they can be moved under certain conditions. In order to eliminate the effects of movement as much as possible, we will restrict our investigation in the following subsections to the relative order of adverbials in the middle field of the clause. Furthermore, we will only discuss sentences with a neutral intonation pattern and avoid the use of weak adverbial proforms.

#### II. VP adverbials

This subsection discusses the unmarked order of the VP adverbials in (188). Since Cinque's (1999) seminal study on adverbial placement, it has often been claimed that the order of VP adverbials is essentially free. Schweikert (2005) and Cinque (2006) dismissed this claim, however, and argued that VP adverbials have a rigid underlying order. This section will show that this claim is indeed correct, although we will end up with somewhat different conclusions about the unmarked order of VP adverbials than the order proposed by Schweikert.

- (188) • VP adverbials
- a. Process: manner; instrument; means; volition; domain
  - b. Agentive: passive *door*-PP; comitative *met*-PP
  - c. Spatio-temporal: place; time
  - d. Contingency: cause, reason, purpose, result, concession
  - e. Predicate-degree: *erg* 'very'; *een beetje* 'a bit'

## A. Process adverbials

We will investigate the unmarked order of the process adverbial by considering the placement of the various subtypes relative to adjectival manner adverbials such as *zorgvuldig* ‘carefully’. Although it is not difficult to find instrument/means adverbials to the left of manner adverbs, as illustrated in the primeless examples in (189), there is cause for assuming that this order is the result of focus movement: the primed examples show that their pronominalized counterpart *ermee* ‘with it’ cannot precede the manner adverb but has to follow it.

- (189) a. Jan heeft de ring *<met een kwast>* *zorgvuldig* *<met een kwast>* gereinigd.  
 Jan has the ring with a brush carefully cleaned  
 ‘Jan has cleaned the ring carefully with a brush.’
- a'. Jan heeft de ring *<\*ermee>* *zorgvuldig* *<ermee>* gereinigd.  
 Jan has the ring with.it carefully cleaned  
 ‘Jan has cleaned the ring carefully with it.’
- b. Jan heeft *<met zand>* *zorgvuldig* het gat *<met zand>* gevuld.  
 Jan has with sand carefully the hole filled  
 ‘Jan has filled the hole carefully with sand.’
- b'. Jan heeft *<\*ermee>* *zorgvuldig* het gat *<ermee>* gevuld.  
 Jan has with.it carefully the hole filled  
 ‘Jan has filled the hole carefully with it.’

Observe that pronominal PPs are preferably split, as in *Jan heeft er de ring zorgvuldig mee gereinigd* and *Jan heeft er zorgvuldig het gat mee gevuld*, but this is not relevant here. Since instrument and means adverbials do not easily co-occur, we will not discuss their relative order here.

Example (190a) shows that manner adverbs tend to precede domain adverbials under a non-contrastive intonation pattern: a Google search (11/3/2015) has shown that the order *medisch–grondig/zorgvuldig* occurred only 5 times, while the order *grondig/zorgvuldig–medisch* resulted in 50 hits. This finding is consistent with the fact that domain adverbials tend to follow instrumental PPs such as *met medicijnen* ‘with medicines’ in example (190b). Recall that the judgments given only hold under a non-contrastive intonation pattern: assigning focus accent to *medisch* much improves the marked order.

- (190) a. Jan is *<??medisch>* *grondig/zorgvuldig* *<medisch>* onderzocht.  
 Jan has.been medically thoroughly/carefully examined  
 ‘Jan has been thoroughly/carefully examined medically.’
- b. HIV kan *<??medisch>* *met medicijnen* *<medisch>* behandeld worden.  
 HIV can medically with medicines treated be  
 ‘HIV can be medically treated with medicines.’

Example (191a) finally shows that volition adverbials precede manner adverbs. By transitivity we can conclude that they will also precede the other process adverbials; that this conclusion is indeed correct is shown in (191b) for a means adverbial.

- (191) a. dat Jan zich <*vrijwillig*> *intensief* <\**vrijwillig*> inzet voor de club.  
 that Jan REFL voluntarily intensively labors for the club  
 ‘that Jan voluntarily dedicates himself to the club intensively.’  
 b. dat Jan het gat <?*met zand*> *vrijwillig* <*met zand*> vulde.  
 that Jan the hole with sand voluntarily filled  
 ‘that Jan voluntarily filled the hole with sand.’

The examples in this subsection thus suggest that the unmarked order of process adverbials is as follows: volition > manner > instrument/means > domain.

### B. Agentive adverbials

The passive construction in (192b) clearly shows that passive *door*-phrases precede comitative *met*-phrases: inverting the order results in a severely degraded result.

- (192) a. dat Marie het artikel met Jan besprak.  
 that Marie the article with Jan discussed  
 ‘that Marie discussed the article with Jan.’  
 b. dat het artikel <*door Marie*> *met Jan* <\**door Marie*> besproken werd.  
 that the article by Marie with Jan discussed was  
 ‘that the article was discussed with Jan by Marie.’

Although it is not difficult to find agentive *door*-phrases to the left of manner adverbs, there is evidence that this order is the result of focus movement: example (193a) shows that the *door*-phrase must follow the manner adverb if the nominal complement of the preposition *door* is a weak pronoun. Since comitative *met*-PPs must follow agentive *door*-PPs, we expect by transitivity that they also follow manner adverbials in the unmarked order: example (193b) shows that this expectation is indeed borne out.

- (193) a. dat het gat <*door Jan*/\**'m*> *zorgvuldig* <*door Jan*/\**'m*> gevuld werd.  
 that the hole by Jan/him carefully filled was  
 ‘that the hole was carefully filled by Jan/him.’  
 b. dat Marie het probleem <*met Jan*/\**'m*> *grondig* <*met Jan*/\**'m*> besprak.  
 that Marie the problem with Jan/him thoroughly discussed  
 ‘that Marie discussed the problem with Jan/him thoroughly.’

Example (194a) shows that comitative *met*-PPs precede instrument/means adverbials in the unmarked order: inverting the order gives rise to a degraded result regardless of the form of the nominal complement of the preposition *met*. Since comitative *met*-PPs follow agentive *door*-PPs in the unmarked order, we expect by transitivity that *door*-phrases also precede instrument/means adverbials; example (194b) shows that this expectation is also borne out.

- (194) a. dat Jan het gat *met Marie*/\**r* *met zand* vulde.  
 that Jan the hole with Marie with sand filled  
 ‘that Jan filled the hole with sand with Marie/her.’  
 b. dat het gat *door Jan*/\**'m* *met zand* gevuld werd.  
 that the hole by Jan/him with sand filled was  
 ‘that the hole was filled with sand by Jan/him.’

The examples in this subsection have established that in the unmarked case agentive adverbials are located between the manner and the instrument/means adverbials, while agentive *door*-PPs precede comitative *met*-PPs. We therefore conclude that the unmarked order of process and agentive adverbials is as follows: volition > manner > agentive > comitative > instrument/means > domain.

### C. Spatio-temporal adverbials

In the middle field of the clause, temporal VP adverbials precede locational VP adverbials, and they both seem most comfortable in a position preceding the manner adverbs, although it is not easy to show conclusively that this is their unmarked position.

- (195) a. dat Jan waarschijnlijk om drie uur in het park gaat wandelen.  
 that Jan probably at 3 o'clock in the park goes walk  
 'that Jan will probably go walking in the park at 3 o'clock.'
- b. dat Jan waarschijnlijk om drie uur zachtjes wegsliipt.  
 that Jan probably at 3 o'clock quietly away-slips  
 'that Jan probably slips away quietly at 3 o'clock.'
- c. dat Jan waarschijnlijk in het park intensief wil trainen.  
 that Jan probably in the park intensively wants train  
 'that Jan probably wants to train intensively in the park.'

It is also difficult to establish the unmarked order of the spatio-temporal and volitional adverbials such as *vrijwillig* 'voluntarily' and *graag* 'gladly', as the latter can easily appear in the positions indicated by "✓" and only marginally appear in the position indicated by the question mark.

- (196) Jan gaat waarschijnlijk <✓> om drie uur <✓> in het park <?> wandelen.  
 Jan goes probably at 3 o'clock in the park walk  
 'Jan will probably go walking gladly in the park at three o'clock.'

We assume provisionally that the volitional adverbs are base-generated above the temporal adverbials and that the alternate orders are derived by leftward movement of the spatio-temporal adverbials. If true, this gives rise to the following unmarked order of VP adverbials: volition > temporal > locational > manner > agentive > comitative > instrument/means > domain.

### D. Contingency adverbials

The examples in (197) show that contingency adverbials precede time adverbials; inverting this order gives rise to an infelicitous result. It is not easy to establish whether the various subtypes of contingency adverbs exhibit an unmarked order, as they do not easily co-occur; we will therefore not digress on this issue.

- (197) a. dat Jan waarschijnlijk door de file te laat in Utrecht zal zijn.  
 that Jan probably by the traffic.jam too late in Utrecht will be  
 'that Jan will probably be in Utrecht too late due to the traffic jam.'
- b. dat Jan waarschijnlijk vanwege het vakantieverkeer vroeg vertrekt.  
 that Jan probably because.of the holiday.traffic early leaves  
 'that Jan will probably leave early because of the holiday traffic.'

- c. dat Jan waarschijnlijk ondanks de file op tijd in Utrecht zal zijn.  
 that Jan probably despite the traffic.jam in time in Utrecht will be  
 ‘that Jan will probably be in Utrecht in time despite the traffic jam.’

Example (198) shows that the contingency adverbials also preferably precede the volition adverbials.

- (198) dat de minister <<sup>??</sup>vrijwillig> vanwege het schandaal <vrijwillig> aftrad.  
 that the minister voluntarily because.of the scandal resigned  
 ‘that the minister resigned voluntarily because of the scandal.’

This means that so far we have established the following unmarked order of VP adverbials: contingency > volition > temporal > locational > manner > agentive > comitative > instrument/means > domain.

### E. Predicate-degree adverbials

VP adverbials such as *erg* in (199) normally follow the locational VP adverbials. Although it is not difficult to find agentive *door*-phrases to the left of predicate-degree adverbials, there is reason for assuming that this is the result of focus movement: Example (199a) shows that the *door*-phrase must follow the degree adverbial if the nominal complement of the preposition *door* is a weak pronoun.

- (199) a. Marie wordt waarschijnlijk <<sup>??</sup>*erg*> in Utrecht <*erg*> bewonderd  
 Marie is probably greatly in Utrecht admired  
 ‘Marie is probably admired greatly in Utrecht.’  
 b. Marie wordt <*door* Peter/\*’m> *erg* <*door* Peter/’m> bewonderd.  
 Marie is by Peter/him greatly admired  
 ‘Marie is greatly admired by Peter/him.’

Because manner and degree adverbials do not seem to co-occur, the examples in (199) make the picture complete by showing that the predicate-degree adverbs are located between the locational and the agentive adverbials in the unmarked case.

### F. Conclusion

The discussion above has shown that VP adverbials exhibit the unmarked word order in (200). Since the relative order of VP adverbials has not received much attention in the literature so far, we have to leave it to future research to investigate whether this linear hierarchy can stand closer scrutiny.

- (200) **Unmarked word order of VP adverbials:**  
 contingency > volition > temporal > locational > manner/predicate-degree >  
 agentive > comitative > instrument/means > domain.

### III. Clause adverbials

This subsection discusses the unmarked word order of the set of clause adverbials in (201), which were also taken as our point of departure in Section 8.2.2. It should be pointed out that this set of clause adverbials is not identical to the set of adverbials that Cinque (1999) locates in the functional domain, as some of these were shown to function as VP adverbials according to the adverbial tests introduced

in Section 8.1; this holds, e.g., for volition adverbials like *vrijwillig* ‘voluntarily’ and *opzettelijk* ‘deliberately’. The main conclusion of our discussion will be, however, that the unmarked order found in Dutch shows a considerable similarity to what is expected on the basis of the Cinque’s cross-linguistic structural hierarchy of adverbials in the functional domain of the clause. His structural, top-down order more or less coincides with the unmarked linear, left-right order in the middle field of the clause.

- (201) a. Polarity: negation (*niet* ‘not’); affirmation (*wel*)  
 b. Focus particles (*alleen* ‘only’, *ook* ‘too’, *zelfs* ‘even’, etc.)  
 c. Aspectual: habitual; iterative; frequentative; continuative; etc.  
 d. Clause-degree (*bijna* ‘nearly’; *amper* ‘hardly’, etc.)  
 e. Propositional modal (*waarschijnlijk* ‘probably’, *blijkbaar* ‘apparently’, etc.)  
 f. Subject-oriented (*stom genoeg* ‘stupidly’, *wijselijk* ‘wisely’, etc.)  
 g. Subjective: factive (e.g., *helaas* ‘unfortunately’); non-factive  
 h. Point-of-view (*volgens Els* ‘according to Els’)  
 i. Spatio-temporal: place; time  
 j. Contingency: cause; reason; condition; concession  
 k. Domain (*juridisch gezien* ‘legally’, *moreel gezien* ‘morally’, etc.)  
 l. Conjunctive (*echter* ‘however’, *derhalve* ‘therefore’, etc.)  
 m. Speech-act related (*eerlijk gezegd* ‘honestly’, etc.)

In order to facilitate the discussion, the adverbials in (201) are already listed in the order that more or less reflects their unmarked linear order in the middle field of the clause, although it is not always easy to demonstrate this because of co-occurrence restrictions. For this reason, we restrict ourselves to a limited subset of clear cases; a more detailed discussion is not possible at this stage for want of sufficiently rich empirical research. We will also divide the clause adverbial types into several larger subgroups. Subsection A starts with the adverbials in (201a-e), which we will refer to as SCOPE-BEARING adverbials, as these can be seen as operators over the proposition expressed by the lexical domain of the verb. Subsection B discusses the adverbials in (201f-h), which we will refer to as EVALUATIVE adverbials as these are involved in providing a subjective evaluation of the proposition expressed by the clause. Subsection C addresses the spatio-temporal and the contingency adverbials in (201i&j) and Subsection D concludes with the remaining cases in (201k-m).

#### A. Scope-bearing adverbials

The polarity adverbials function as the demarcations *par excellence* of the boundary between the lexical and the functional domain: in non-contrastive contexts, they are followed by the VP adverbials and preceded by the clause adverbials. We illustrate this in (202) for the comitative VP adverbial *met* ‘m’ ‘with him’ and the epistemic clause adverbial *waarschijnlijk* ‘probably’.

- (202) dat Marie *waarschijnlijk* niet/wel met ‘m’ wil spelen.  
 that Marie probably not/AFF with him wants play  
 ‘that Marie probably wants/doesn’t want to play with him.’

Note in passing that there are robust reasons for assuming that at least the negative adverb *niet* is located in the specifier position of a functional projection NegP, which may also be the landing site of larger negative phrases in the clause; if so, it shows clearly that negation itself is part of the functional domain of the clause. We will not digress on this here but refer the reader to Section 13.3.1 for extensive discussion.

Example (203a) illustrates that focus particles such as *ook* ‘also’ are placed between the epistemic modals and the polarity adverbials. Example (203b) shows that contrastively focused phrases may occupy the same position as focus particles; for this reason, Section 13.3.2 argues that focus particles are part of a functional projection FocP. Note in passing that the negative adverb *niet* can easily substitute for affirmative *wel* in these examples.

- (203) a. dat Marie *waarschijnlijk ook wel* met 'm wil spelen.  
 that Marie probably also AFF with him wants play  
 ‘that Marie probably also wants to play with him.’
- b. dat Marie *waarschijnlijk ook met HEM wel* wil spelen.  
 that Marie probably also with him AFF wants play  
 ‘that Marie probably also wants to play with HIM.’

Aspectual adverbials precede the focus particles but follow the modal epistemic modals. We illustrate this for the habitual adverbial *gewoonlijk* ‘usually’; example (204a) shows that it must precede the focus particle *ook*, while the slightly awkward example in (204b) shows that it must follow the epistemic modal *waarschijnlijk*.

- (204) a. dat Marie *gewoonlijk ook wel* met 'm wil spelen.  
 that Marie usually also AFF with him wants play  
 ‘that Marie usually does want to play with him as well.’
- b. dat Marie *waarschijnlijk gewoonlijk wel* met 'm wil spelen.  
 that Marie probably usually AFF with him wants play  
 ‘that probably Marie usually does wants to play with him.’

Example (205a) shows that the clause-degree adverbial *bijna* can precede focus particles such as *ook*, but that it is not entirely impossible to have it after the focus particles. In many cases the second order is fully acceptable but this may be due to the fact that *bijna* can also be used as a non-clausal modifier; cf. *bijna leeg* ‘nearly empty’. The somewhat awkward construction in example (205b) shows that clause-degree adverbials follow the epistemic modals.

- (205) a. dat Marie <*bijna*> *ook* <<sup>?</sup>*bijna*> met 'm ging spelen.  
 that Marie nearly also with him went play  
 ‘that Marie nearly started to play with him as well.’
- b. dat Marie *waarschijnlijk bijna ook* met 'm ging spelen.  
 that Marie probably nearly also with him went play  
 ‘that Marie probably nearly also started to play with him.’

We conclude from the examples in (205) that clause-degree adverbials are located in between the epistemic modals and the focus particles but it is clear that this must be a preliminary conclusion: more research is needed to establish this more firmly.



Above it was already shown for the epistemic modals that propositional-modal adverbials precede negation, focal particles, frequentative adverbial and clause-degree adverbials. The fact that the epistemic modal *waarschijnlijk* ‘probably’ in the examples given above can easily be replaced by *blijkbaar* ‘evidently’ shows that this also holds for evidential modals. Since the epistemic and evidential modal adverbials do not easily co-occur, we will not speculate on their relative order.

The discussion above has shown that scope-bearing clause adverbials exhibit the unmarked word order in (206). Because relatively little research on Dutch has been done in this area, our conclusions should be considered provisional.

- (206) **Unmarked word order of scope-bearing clause adverbials:**  
 propositional modal > clause-degree > aspectual > focus > negation

### B. Evaluative adverbials

The placement of subject-oriented adverbials such as *wijzelijk* ‘wisely’ with respect to the scope adverbials discussed in the previous subsection is not entirely clear. Example (207a) first provides a clear example showing that speaker-oriented adverbials must precede focus particles and negation; the asterisks indicate positions in which subject-oriented adverbials cannot occur. Example (207b) shows that subject-oriented adverbials can easily precede aspectual adverbials such as habitual *gewoonlijk*, but placing them after *gewoonlijk* is at least marginally possible. The slightly awkward (c)-examples, finally, show that for some speakers the relative order of the subject-oriented and propositional adverbials is essentially free; judgments seem to vary from speaker to speaker and from instance to instance.

- (207) a. dat Marie <*wijzelijk*> ook <\*> niet <\*> met 'm wil spelen.  
 that Marie wisely also not with him wants play  
 ‘that Marie wisely doesn’t want to play with him either.’
- b. dat Marie <*wijzelijk*> *gewoonlijk* <? *wijzelijk*> niet met 'm wil spelen.  
 that Marie wisely usually not with him wants play  
 ‘that wisely Marie normally/often doesn’t want to play with him.’
- c. dat Marie *wijzelijk* *waarschijnlijk* <#> niet met 'm wil spelen.  
 that Marie wisely probably not with him wants play  
 ‘that wisely Marie probably doesn’t want to play with him.’
- c'. dat Marie *wijzelijk* *blijkbaar* <#> niet met 'm wil spelen.  
 that Marie wisely evidently not with him wants play  
 ‘that wisely Marie apparently doesn’t want to play with him.’

We provisionally conclude from (207) that speaker-oriented adverbials precede all scope adverbials with the exception of the propositional modal adverbials. That their ordering vis-a-vis propositional modals is not very strict may be related to the fact that at least the epistemic modals are also evaluative, in the sense that they too provide an assessment of the state-of-affairs expressed by the clause.

Subjective adverbials like *gelukkig* ‘fortunately’ and *helaas* ‘unfortunately’ are factive in the sense that they imply that the proposition is true; this accounts for the fact illustrated in (208) that they always give rise to an awkward result in combination with propositional adverbials, as these crucially do not presuppose the truth of the proposition.



- (208) a. <sup>§</sup>dat Jan <gelukkig> waarschijnlijk <gelukkig> vertrekt.  
 that Jan fortunately probably leaves
- b. <sup>§</sup>dat Jan <helaas> waarschijnlijk <helaas> vertrekt.  
 that Jan unfortunately probably leaves

Example (209) shows that non-factive subjective adverbials such as *naar ik vrees* ‘as I fear’ must precede the propositional modals such as *waarschijnlijk* ‘probably’ (unless *naar ik vrees* is preceded and followed by an intonation break, in which case we are dealing with an epenthetic construction). We therefore conclude that the subjective adverbials precede the propositional adverbials in the unmarked order.

- (209) dat Marie *naar ik vrees* waarschijnlijk niet met 'm wil spelen.  
 that Marie as I fear probably not with him wants play  
 ‘that I fear that Marie probably doesn’t want to play with him.’

Subjective adverbials and epistemic modals provide an assessment of the state-of-affairs referred to by the sentence. The default interpretation is that the assessment is the speaker’s but this interpretation can easily be overridden by contextual information. One way of doing this is by using a point-of-view adverbial such as *volgens Els* ‘according to Els’; cf. Section 8.2.2, sub VIII. The examples in (210) show that such adverbials precede the subjective and epistemic modal adverbials: this might be a matter of scope, given that the interpretation of the latter depends on the former, but this is probably not the full story because subsection C will show that they also precede spatio-temporal and contingency adverbials.

- (210) a. Jan komt <volgens Els> zeker <<sup>??</sup>volgens Els> op visite. [epistemic]  
 Jan comes according.to Els certainly on visit
- b. Jan bleef <volgens Els> wijselijk <<sup>??</sup>volgens Els> thuis. [subject-oriented]  
 Jan stayed according.to Els wisely at.home
- c. Jan is <volgens Els> gelukkig <<sup>??</sup>volgens Els> ontslagen. [subjective]  
 Jan is according.to Els fortunately fired

The discussion in this subsection has shown that we can extend the word-order generalization in (206) to the one in (211). Our conclusions should again be considered as preliminary, for the reason indicated in the previous subsection.

- (211) **Unmarked word order of scope-bearing and evaluative clause adverbials:**  
 point-of-view > subjective > subject-oriented/propositional modal > clause-degree > aspectual > focus > negation

### C. Spatio-temporal and contingency adverbials

The examples in (212) show that clausal spatio-temporal adverbials can easily precede the propositional modals. That spatio-temporal adverbials cannot follow the propositional adverbials is sometimes difficult to demonstrate because the resulting strings are often acceptable under an alternative analysis: for instance, *morgenvroeg* in *dat Jan waarschijnlijk morgenvroeg vertrekt* ‘that Jan will probably leave early tomorrow’ clearly functions as a one-word VP adverbial. We refer to Section 8.2

for an extensive discussion on determining the actual status of spatio-temporal adverbials as VP or as clause adverbials.

- (212) a. dat Jan morgen waarschijnlijk vroeg vertrekt.  
 that Jan tomorrow probably early leaves  
 ‘that Jan will probably leave early tomorrow.’  
 b. dat Jan in Utrecht waarschijnlijk bij zijn tante logeert.  
 that Jan in Utrecht probably with his aunt stays  
 ‘that Jan will probably stay with his aunt in Utrecht.’

The examples in (213) show that clausal spatio-temporal adverbials can also precede subject-oriented adverbs such as *wijselijk* ‘wisely’ and subjective adverbials such as *helaas* ‘unfortunately’, although the reverse order seems at least marginally possible, too.

- (213) a. dat Jan <morgen> helaas/wijselijk <<sup>(?)</sup>morgen> niet komt.  
 that Jan tomorrow unfortunately/wisely not comes  
 ‘that Jan unfortunately/wisely won’t come tomorrow.’  
 b. dat Jan <in Utrecht> helaas/wijselijk <<sup>(?)</sup>in Utrecht> niet overnacht.  
 that Jan in Utrecht unfortunately/wisely not stays.overnight  
 ‘that Jan unfortunately/wisely won’t spend the night in Utrecht.’

Point-of-view adverbials such as *volgens Els* ‘according to Els’, on the other hand, preferably precede the spatio-temporal adverbials; this illustrated in (214).

- (214) a. dat Jan <<sup>??</sup>morgen> volgens Els <morgen> niet komt.  
 that Jan tomorrow according.to Els not comes  
 ‘that according to Els Jan won’t come tomorrow.’  
 b. dat Jan <<sup>??</sup>in Utrecht> volgens Els <in U.> waarschijnlijk overnacht.  
 that Jan in Utrecht according.to Els probably stays.overnight  
 ‘that according to Els Jan will probably spend the night in Utrecht.’

Contingency adverbials can precede or follow the clausal spatio-temporal adverbials; we illustrate this in (215) for the reason adverbial *wegens ziekte* ‘because of illness’ only. It seems that the order in which they precede the spatio-temporal adverbials is somewhat more natural but the contrast is not sharp, so we will leave it for later to determine the unmarked order more precisely. Example (215c) further shows that contingency adverbials prefer to precede subject-oriented adverbials.

- (215) a. dat Els <morgen> vanwege ziekte <morgen> waarschijnlijk niet zingt.  
 that Els tomorrow because.of illness probably not sings  
 ‘that Els probably won’t sing tomorrow because of illness.’  
 b. dat Els <in Utrecht> vanwege ziekte <in U.> waarschijnlijk niet zingt.  
 that Els in Utrecht because.of illness probably not sings  
 ‘that Els probably won’t sing in Utrecht because of illness.’  
 c. dat Els morgen <<sup>??</sup>wijselijk> vanwege ziekte <wijselijk> niet zingt.  
 that Els tomorrow wisely because .of illness not sings  
 ‘that Els wisely won’t sing tomorrow because of illness.’

We provisionally conclude on the basis of the examples in this subsection that the spatio-temporal and contingency adverbials are located between the point-of-view and the subjective adverbials, although there is still unclarity about the unmarked order of the spatio-temporal and the subjective/subject-oriented adverbials.

- (216) **Unmarked word order of clause adverbials:** point-of-view > contingency/spatio-temporal > subjective > subject-oriented/ propositional modal > clause-degree > aspectual > focus > negation

#### D. Remaining cases

Domain adverbials such as *juridisch gezien* ‘legally speaking/from a legal point of view’ in (217) are relatively high in the functional domain in the clause. Because they restrict the application of the complete clause, there is a strong tendency to place them in sentence-initial position, but they may also occur in the middle field of the clause.

- (217) a. *Juridisch gezien* heeft Jan waarschijnlijk gelijk.  
 legally seen has Jan probably right  
 ‘Legally speaking, Jan is probably correct.’  
 b. Jan heeft *juridisch gezien* waarschijnlijk gelijk.  
 Jan has legally seen probably right

Something similar holds for speech-act related adverbials such as *eerlijk gezegd* ‘honestly speaking’ in (218). Because they comment on the speech act as a whole, there is a strong tendency to place them in sentence-initial position but, again, they may occur in the middle field of the clause.

- (218) a. *Eerlijk gezegd* kan ik het niet geloven.  
 honestly spoken can I it not believe  
 ‘Honestly speaking, I cannot believe it.’  
 b. Ik kan het *eerlijk gezegd* niet geloven.  
 I can it honestly spoken not believe

It is, however, not easy to determine their unmarked position in the middle field of the clause more precisely: the examples in (219) show, for instance, that the domain and speech-act related adverbials can be placed before or after the clausal temporal adverbials. Judgments seem to differ from case to case and person to person, and both orders can be found on the internet.

- (219) a. Jan had *<juridisch gezien>* gisteren *<juridisch gezien>* gelijk.  
 Jan had legally seen yesterday right  
 ‘Legally speaking, Jan was right yesterday.’  
 b. Ik kon het *<eerlijk gezegd>* gisteren *<eerlijk gezegd>* niet geloven.  
 I could it honestly spoken yesterday not believe  
 ‘Honestly speaking, I couldn’t believe it yesterday.’

An additional problem for determining the unmarked position of domain and speech-act adverbials more precisely is that they often occur as parentheticals. This is especially clear for the speech-act adverbial *eerlijk gezegd*, as the examples in

(220) show that it may also precede the first position of the sentence or be placed in clause-final position; the comma's indicate an intonation break.

- (220) a. *Eerlijk gezegd*, ik kan het niet geloven.  
 honestly spoken I can it not believe  
 b. Ik kan het niet geloven, *eerlijk gezegd*.  
 I can it not believe honestly spoken

Similar problems arise for conjunctive adverbials such as *echter* 'however' in (221), which can be used at various positions in the sentence. The options available seem to differ from case to case.

- (221) a. *Echter*, Jan zal morgen waarschijnlijk vroeg vertrekken.  
 however Jan will tomorrow probably early leave  
 'However, Jan will probably leave early tomorrow.'  
 b. Jan, *echter*, zal morgen waarschijnlijk vroeg vertrekken.  
 c. Jan zal *echter* morgen waarschijnlijk vroeg vertrekken.  
 d. Jan zal morgen *echter* waarschijnlijk vroeg vertrekken.

Because the word order problems pointed out above have not yet been investigated in greater depth, it seems premature to speculate on the precise unmarked position of these adverbials: we can only conclude that they are relatively high in the linear hierarchy in (216).

#### IV. Conclusion

This section has discussed the unmarked order of adverbial phrases. In order to eliminate the effects of movement as much as possible we restricted our attention to the order of adverbials in the middle field of the clause. Furthermore, we excluded sentences with contrastive accent and adverbial proforms. Our investigation has shown that both the VP adverbials as well as the clause adverbials are subject to ordering restrictions. The two linear hierarchies in (222) summarize our findings. We did not include the domain, speech-act related and conjunctive adverbials in these hierarchies: although it is clear that they are located high up in the hierarchy in (222a), it is difficult for various reasons to locate them more precisely.

- (222) • **Unmarked word order of adverbials in the middle field of the clause**  
 a. *Clause adverbials*: point-of-view > contingency/spatio-temporal > subjective > subject-oriented/ propositional modal > clause-degree > aspectual > focus > negation  
 b. *VP adverbials*: contingency > volition > temporal > locational > manner/predicate-degree > agentive > comitative > instrument/means > domain.

Because the ordering of clause adverbials has not been studied in very great detail so far in the literature on Dutch, the proposed ordering should be considered preliminary, pending further investigation. Cinque's (1999) typological work suggests, for example, that (222a) can be fine-tuned by adding more fine-grained distinctions. Other problems complicating the investigation are the (semantic) co-occurrence restrictions we occasionally find as well as the fact that sometimes more than one linear order is fully acceptable.

### 8.5. Obligatory adverbial phrases

Adverbial phrases differ from °arguments in that they are optional in the prototypical case. There are cases, however, in which a verb is obligatorily accompanied by an adverbial-like phrase. A typical instance is the verb *wonen* ‘to live’ in (223), which must be combined with a locational PP or an AP denoting a property of the accommodation or the surroundings where the subject of the clause lives.

- (223) a. Jan woont in Tilburg/in een comfortabel huis/in een mooie omgeving.  
 Jan lives in Tilburg/in a comfortable house/in a nice surrounding  
 ‘Jan lives in Tilburg/in a comfortable house/in nice surroundings.’  
 b. Jan woont comfortabel/klein/gezellig.  
 Jan lives comfortably/small/cozy  
 b’. Jan woont mooi/landelijk.  
 Jan lives beautifully/rurally

It is not immediately clear that the syntactic function of the PPs and APs is really adverbial. They are often called complements because the verb normally cannot occur without them, which takes the selectional property of the verb to be of a syntactic nature. However, this conclusion is perhaps too easy, given that the obligatory presence of a PP/AP may also be due to pragmatics: in accordance with Grice’s cooperative principle, the sentence *Jan woont* may be dismissed as uninformative because the proposition expressed by it is already presupposed to be true for all people. The same is true for examples with *geboren worden*: an example such as *Jan is geboren* is simply not informative; another similar case is *zich gedragen* ‘to behave’, which only occurs without an adverbial phrase in imperatives if the behavior of the addressee is inappropriate: *Gedraag je!* ‘Behave yourself!’.

- (224) a. Jan is geboren in 1970.  
 Jan is born in 1970  
 b. Jan is te vroeg geboren.  
 Jan is too early born  
 ‘Jan was born prematurely.’

The same may hold for verbs selecting measure phrases like *duren* ‘to last’, *kosten* ‘to cost’, *meten* ‘to measure’ and *wegen* ‘weigh’, which were discussed in Section 2.4. Example (225a) shows for *duren* that these verbs normally need an extra constituent that evidently does not function as argument; omitting the addition results in an uninformative sentence as performances always have some duration. That this account may be on the right track is suggested by examples such as (225a): the sentence *Het vriest* ‘It freezes’ is informative in itself and consequently does allow omission of the measure phrase.

- (225) a. De voorstelling duurt lang/drie uur/tot tien uur.  
 the performance lasts long/three hours/until 10 o’clock  
 b. Het vriest (streng/15 graden).  
 it freezes severely/15 degrees

We conclude from the discussion above that adverbial phrases are always optional as far as syntax is concerned, but that there may be pragmatic reasons for obligatorily including an adverbial phrase with certain verbs.

### **8.6. Bibliographical notes**

Adverbs/adverbials have figured prominently in the literature on semantics, but they have received relatively little attention in the syntactic literature. The discussion in this chapter has taken as its point of departure the division between clause adverbials and VP adverbials; cf. Jackendoff (1972), and also Kraak & Klooster (1972:ch.9) and Van den Hoek (1972). The semantic subdivision of these two main groups described in Section 8.2 more or less follows the divisions found in Quirk et al. (1985) and Huddleston & Pullum (2002). Although we diverge from Haeseryn et al. (1997) in that we deny the existence of a separate category of adverbs, this work has provided a solid empirical basis for our discussion in Section 8.3 of the categorial form of adverbial phrases. Although the linear order of adverbials phrases has received attention in the generative literature since Van den Hoek (1972) and Koster (1974), this has not led to greater insight in the nature of the restrictions that determine this order. The issue was put firmly on the research agenda with the publication of Cinque (1999/2006) and Schweikert (2005), who claimed (for all languages) that adverbials are base-generated in fixed structural positions in the clause. The syntactic approach was soon challenged by Ernst (2002), who claims that the distribution of adverbials is basically determined by semantic factors. The debate, which is still ongoing, has revived the interest in the distributional aspects of adverbials, as is clear from the articles collected by Artemis Alexiadou in *Lingua* 114/6 (theme issue: *Adverbs across frameworks*), which provide reviews of a number of selected recent approaches to this topic. More general introductions to the literature on adverbs and adverbial phrases are Delfitto (2006) and Maienborn & Schäfer (2011).



# **Chapter 9 Word order in the clause I: General introduction**

<b>Introduction</b>	<b>1204</b>
<b>9.1. The overall organization of the clause</b>	<b>1205</b>
<b>9.2. The position of the verbs</b>	<b>1208</b>
<b>9.3. The clause-initial position</b>	<b>1215</b>
<b>9.4. The postverbal field</b>	<b>1221</b>
<b>9.5. The middle field</b>	<b>1230</b>
<b>9.6. Conclusion</b>	<b>1241</b>



**Introduction**

It has been a long-standing insight in Dutch syntax that the clause can be divided into several topological fields which can be defined by means of the positions that can be occupied by verbs: the  $\circ$ verb-second position, which is occupied by finite verbs in main clauses, and the so-called clause-final verb position, in which the remaining verbs find a place. In the examples in (1) these verb positions are shown in italics. Note that we will follow the general practice of abbreviating the notions of ‘‘verb-second’’ and ‘‘clause-final verb’’ position as ‘‘second’’ and ‘‘clause-final’’ position; this is not problematic as long as one does not take the notion ‘‘clause-final’’ too literally because the verb(s) occupying this position can be followed by other material.

- (1) a. Gisteren *is* Jan naar de dierenarts *geweest* met zijn hond.  
 yesterday is Jan to the vet been with his dog  
 ‘Jan went to the vet with his dog yesterday.’  
 b. Hoe *wil* Jan dat boek *versturen* naar zijn dochter?  
 how wants Jan that book send to his daughter  
 ‘How does Jan want to send that book to his daughter?’

Since Paardekooper (1961) it has generally been assumed that the verb-second position in examples such as (1) is identical to the position occupied by the complementizers *dat* ‘that’ and *of* ‘if/whether’ in their embedded counterparts in (2); in such examples the finite verb forms a  $\circ$ verb cluster with the non-finite verbs in clause-final position. Note that the complementizer *of* in *wh*-questions like (2b) is optional in colloquial speech (and normally not realized in writing/formal speech).

- (2) a. Ik denk [dat Jan gisteren naar de dierenarts *is geweest* met zijn hond].  
 I think [that Jan yesterday to the vet is been with his dog  
 ‘I think that Jan went to the vet with his dog yesterday.’  
 b. Ik vroeg [hoe (of) Jan dat boek *wil versturen* naar zijn dochter]?  
 I asked how if Jan that book wants send to his daughter  
 ‘I asked how Jan wants to send that book to his daughter.’

With the help of the two verb positions introduced above, we can define three topological fields, as indicated in (3). The clause-initial position can contain at most one constituent, which normally has some specific information-structural function: it can be a question word, a discourse topic, a contrastively focused element, etc. The middle field may contain constituents of various types, such as nominal and prepositional  $\circ$ arguments,  $\circ$ complementives, and adverbial phrases. The same holds for the postverbal field, which normally contains longer constituents, such as  $\circ$ complement clauses, relative clauses, and adverbial phrases/clauses.

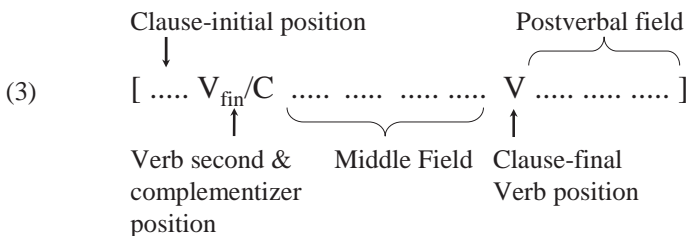

Although distinguishing these topological fields is very useful in discussing word order, Section 9.1 will show that using the positions and fields distinguished in (3) is not unproblematical since they do not seem to have an independent theoretical status; we will therefore in due course replace the structure in (3) by the somewhat more sophisticated structural representation of the clause in (4); this representation shows that especially the (linear notion of) middle field crosses various (hierarchical) domain boundaries normally assumed in generative grammar.

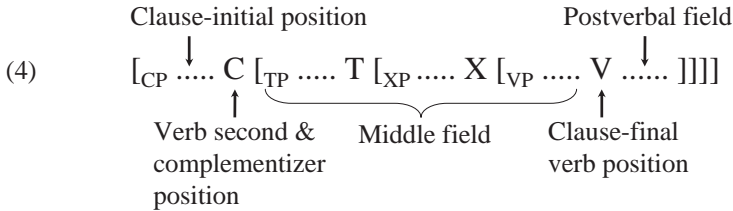

This chapter also aims at providing a bird’s eye view of the overall organization of the clause by briefly introducing a number of °movement phenomena affecting the linear order of the clause: verb-second (Section 9.2), *wh*-movement and topicalization (Section 9.3), extraposition (Section 9.4), and scrambling (Section 9.5). These phenomena will be discussed in greater detail in Chapter 10 to Chapter 13; readers who are primarily interested in browsing through the relevant data may go to these chapters immediately.

**9.1. The overall organization of the clause**

The aim of this section is to provide a bird’s eye view of the organization of the clause in Standard Dutch and to discuss some of the °movements involved in the derivation of the surface forms in actual utterances. Roughly speaking, the clause consists of two main parts, which will be referred to as the lexical and the functional domain. The LEXICAL DOMAIN consists of the main verb and its °arguments as well as certain types of °modifiers (such as manner adverbs), which together form a proposition. In (5a), for example, the verb *kopen* ‘to buy’ takes a direct object as its complement and is subsequently modified by the manner adverb *snel* ‘quickly’, and the resulting complex predicate is finally predicated of the noun phrase *Jan*. The complex phrase thus formed expresses the proposition that can be represented by means of the logical formula in (5b).

- (5) a. [Jan [snel [het boek kopen]]  
           Jan quickly the book buy
- b. BUY QUICKLY (Jan, the book)

Infinitival clauses such as (5a) are normally not acceptable as independent sentences of Dutch, although they do occur in the special context exemplified in (6b), in which participant B expresses surprise about something said by participant A.

- (6) a. Jan zal straks snel een boek kopen. [participant A]  
 Jan will later quickly a book buy  
 ‘Jan will quickly buy a book later.’  
 b. Jan/Hij snel een boek kopen? Niet te geloven! [participant B]  
 Jan/he quickly a book buy not to believe  
 ‘Jan/Him buying a book? I can’t believe it!’

That structures such as (5a) do not normally represent acceptable sentences does not imply that the string as such is not syntactically well-formed. This will be clear from the fact that (5a) can be used as, e.g., the complement of the permissive verb *laten* ‘to let’ in (7a). The structure as a whole has the propositional content in (7b), in which the proposition in (5b) is embedded in a larger proposition.

- (7) a. Marie liet [Jan [snel [het boek kopen]]]  
 Marie let Jan quickly the book buy  
 ‘Marie let Jan buy the book quickly.’  
 b. LET<sub>permission</sub> (Marie, BUY QUICKLY (Jan, the book))

The acceptability of (7a) shows that unacceptability of (5a) as independent utterance cannot be attributed to the string *Jan snel het boek kopen* as such, but must be attributed to other factor(s). More specifically, the contrast between (5a) and (7a) shows that, although propositions as such are well-formed expressions of artificial languages like predicate calculus, they must be supplemented with additional information in order to be usable as sentences in natural languages. One such piece of information is TENSE: in order to be usable as a sentence, a proposition must be situated in time, as in (8).

- (8) a. Jan koopt<sub>present</sub> snel het boek.  
 Jan buys quickly the book  
 ‘Jan quickly buys the book.’  
 b. Jan kocht<sub>past</sub> snel het boek.  
 Jan bought quickly the book  
 ‘Jan quickly bought the book.’

Given that the infinitival clause *Jan snel het boek kopen* can be used in (7a), in which the temporal information is expressed by the past tense on the verb form *liet* ‘let’, we may conclude that this information is external to the lexical domain. For this reason it has been proposed that the lexical domain of the verb is embedded in a larger FUNCTIONAL DOMAIN. The latter domain contains not only temporal information but also information about the ILLOCUTIONARY FORCE of the expression; for example, it provides an answer to the question as to whether we are dealing with an assertion or with a question. In finite embedded clauses this information is often provided by complementizers: the complementizer *dat* ‘that’ is used for embedded declarative clauses, whereas *of* ‘whether’ is used for embedded questions.

- (9) a. Marie vertelde [dat Jan ziek is]. [embedded declarative clause]  
 Marie told that Jan ill is  
 ‘Marie said that Jan is ill.’

- b. Marie vroeg [of Jan ziek is]. [embedded interrogative clause]  
 Marie asked whether Jan ill is  
 ‘Marie asked whether Jan is ill.’

Given that complementizers are words normally, it has been claimed that they occupy °head positions in the functional domain of the clause. A similar line of reasoning claims that the temporal information of the clause is introduced as a temporal head in the functional domain of the clause. If correct, this would lead us to the schematic representation of the clause in (10), in which C stands for the head position of the complementizer, T for the head position containing the tense features of the finite verb, and X for other functional heads in the clausal domain (if any). Like lexical heads such as V, functional heads are taken to project and thus form a CP, a TP, and an XP. The projections of V (as well as the other lexical categories N, A and P) and functional heads will be referred to as lexical and functional projections, respectively. When referring to both the lexical and the functional domain we will use the term EXTENDED PROJECTION of the lexical head; see Grimshaw (1991) for the origin of this notion.

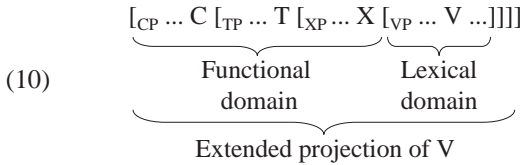

The dots in structure (10) are positions allocated to specific clausal elements (subject, object, *wh*-phrase, etc.), which appear as so-called SPECIFIERS of the lexical and functional heads. These specifiers may be base-positions, in which certain phrases are lexically inserted, or derived positions, to which certain phrases are moved from other positions in the course of the derivation.

Although the hierarchical structure in (10) is not accepted in all quarters of linguistics, it is quite generally adopted among generative linguists as universally valid for natural language: specific languages are derived by means of language-specific and sometimes construction-specific restrictions on the position occupied by the verb in the output of the grammar (C, T, X or V), and something similar holds for the position of the arguments and modifiers of the clause. This does not alter the fact, of course, that postulating a structure like the one in (10) and concomitant movements are highly theory-internal. However, readers who object to the movement metaphor from generative grammar may think of structure (10) as the template in (11), in which the positions C, T, X and V indicate potential positions for the expression of the verb and in which the dots are designated positions for the expression of certain phrasal constituents (XPs) of the clause. The movements postulated in generative grammar can then be thought of as language- and construction-specific expression rules determining in which positions of the universal template the verb(s) and the phrasal constituents of the clause surface. Templates such as (11) are also known from theoretical frameworks that do not postulate movement; see, e.g., the abstract term PATROON (pattern) in Paardekooper (1960) or the term FUNCTIONAL PATTERN in Dik (1978).

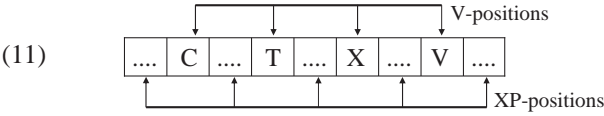

We want to emphasize again that we are not claiming that (10) and (11) exhaust the structural description of the clause; it may well be that the lexical and the functional domain contain more heads than indicated here. Nor is it *a priori* clear that the lexical and the functional information are as neatly separated as suggested by (10) and (11); it might well be the case that these types of information are intermingled in a more intricate manner. This section will merely use structure (10) to provide a global description of the data that have been prominent in the discussion on clause structure of Dutch in the generative literature over the last four decades (and which, in our view, should be accounted for in any theory) in order to provide the reader with some basic information that may be helpful in reading the present chapter. The reader will note in the following discussions that despite 50 years of intensive generative research many issues concerning clause structure are still unresolved and give rise to a continuing debate.

**9.2. The position of the verbs**

This section discusses a number of basic facts concerning the placement of verbs in Dutch clauses. Subsection I starts by showing that in main clauses there are (at least) two verb positions; the so-called verb-first/second position, in which we find the finite verb, and the so-called clause-final verb position, where we find the remaining, non-finite verbs. In the (a)-examples in (12) the main verb is finite and therefore found in verb-first/second position whereas in the (b)-examples the main verb is non-finite and therefore found in clause-final position; the verb-first/second position in the (b)-examples is occupied by the finite auxiliary *heeft* ‘has’.

- (12)
- Main clauses
    - a. Jan *leest* het boek morgen. [verb-second]  
 Jan reads the book tomorrow  
 ‘Jan will read the book tomorrow.’
    - a’. *Leest* Jan het boek morgen? [verb-first]  
 reads Jan the book tomorrow  
 ‘Will Jan read the book tomorrow?’
    - b. Jan *heeft* het boek gisteren *gelezen*. [verb-second & clause-final]  
 Jan has the book yesterday read  
 ‘Jan read the book yesterday.’
    - b’. *Heeft* Jan het boek gisteren *gelezen*? [verb-first & clause-final]  
 has Jan the book yesterday read  
 ‘Did Jan read the book yesterday?’

Subsection II will show that this asymmetry in the placement of finite and non-finite verbs does not occur in embedded clauses; finite and non-finite verbs all appear in clause-final position, as illustrated by (13). We will see that there are reasons for assuming that here the verb-second position is occupied by the complementizer *dat* ‘that’ or *of* ‘whether’

- (13) • Embedded clauses
- a. Ik weet dat Jan het boek morgen *leest*. [clause-final]  
 I know that Jan the book tomorrow reads  
 ‘I know that Jan will read the book tomorrow.’
- a’. Hij vroeg of Jan het boek morgen *leest*. [clause-final]  
 he asked if Jan the book tomorrow reads  
 ‘He asked whether Jan will read the book tomorrow.’
- b. Ik weet dat Jan het boek gisteren *gelezen heeft*. [clause-final]  
 I know that Jan the book yesterday read has  
 ‘I know that Jan read the book yesterday.’
- b’. Hij vroeg of Jan het boek gisteren *gelezen heeft*. [clause-final]  
 he asked if Jan the book yesterday read has  
 ‘He asked whether Jan read the book yesterday.’

Subsection III will conclude the discussion of verb placement by giving the standard analysis in generative grammar of this difference between main and embedded clauses. Note that here we do not discuss the order of the verbs in clause-final position; this issue is dealt with extensively in Chapter 7.

### I. Main clauses

Examples (14a&b) show that verbs may occur in various places in the main clause; finite verbs occupy a position in the left periphery of the clause, whereas participles and infinitives occupy a position more to the right. Work in the structuralist tradition, such as Haeseryn et al. (1997), often refers to the position of the finite verb as the first pole of the clause and the position of the non-finite verb(s) as the second pole of the clause. Example (14c) shows that the second pole may remain empty when there are no non-finite verbs to fill it.

- (14) a. Jan heeft<sub>finite</sub> Marie deze ansichtkaart toegestuurd<sub>participle</sub> vanuit China.  
 Jan has Marie this postcard prt.-sent from China  
 ‘Jan has sent Marie this postcard from China.’
- b. Jan wilde<sub>finite</sub> Marie deze ansichtkaart toesturen<sub>inf</sub> vanuit China.  
 Jan wanted Marie this postcard prt.-send from China  
 ‘Jan wanted to send Marie this postcard from China.’
- c. Jan stuurde<sub>finite</sub> Marie deze ansichtkaart toe vanuit China.  
 Jan sent Marie this postcard prt from China  
 ‘Jan sent Marie this postcard from China.’

Using the idea of the two poles, we can divide main can be divided into three subdomains. The first subdomain consists of the position preceding the finite verb. This position is often occupied by the subject, as in the examples in (14) above, but the primeless examples in (15) show that it can also be occupied by, e.g., a questioned or topicalized direct object. The crucial observation, however, is that the finite verb can normally be preceded by just a single constituent; this will be clear from the fact illustrated in the primed examples in (15) that filling the position preceding the finite verb by a constituent other than the subject requires the subject to be placed *after* the finite verb; leaving the subject *Jan* in the position preceding the finite verb results in an ungrammatical sentence.

- (15) a. Wat heeft Jan Marie toegestuurd vanuit China?  
 what has Jan Marie prt.-sent from China  
 ‘What did Jan send Marie from China?’  
 a’. \*Wat Jan heeft Marie toegestuurd vanuit China?  
 b. Deze ansichtkaart heeft Jan Marie toegestuurd vanuit China.  
 this postcard has Jan Marie prt.-sent from China  
 ‘This postcard Jan has sent to Marie from China.’  
 b’. \*Deze ansichtkaart Jan heeft Marie toegestuurd vanuit China.

Since the position preceding the finite verb can contain at most one constituent, this position is often referred to as the *CLAUSE-INITIAL POSITION*; in keeping with this, the position of the finite verb is often referred to as the *SECOND POSITION* of the clause in order to contrast it with the *CLAUSE-FINAL POSITION* occupied by the non-finite verbs. The examples in (15) show that the term *clause-final position* is somewhat misleading, given that verbs in this position can be followed by other elements. The examples in (16) show that this is easily possible in the case of *PP-complements* and even obligatory in the case of *clausal complements*. The positions following the verb(s) in *clause-final position* will be referred to as *POSTVERBAL POSITIONS*.

- (16) a. Jan wil Marie <\*of zij komt> vragen <of zij komt>.  
 Jan wants Marie whether she comes ask  
 ‘Jan wants to ask Marie whether she will come.’  
 b. Jan wil niet langer <op Marie> wachten <op Marie>.  
 Jan wants no longer for Marie wait  
 ‘Jan doesn’t want to wait for Marie any longer.’

Given that the *clause-initial position* is normally filled by some constituent in declarative clauses and *wh*-questions, the term *verb-second position* is quite appropriate for such cases. There are, however, also cases in which the initial position remains empty so that the verb ends up in first position. This holds, e.g. for *yes/no*-questions such as (17).

- (17) Heeft Jan Marie dit ansichtkaart toegestuurd vanuit China?  
 has Jan Marie this postcard prt.-sent from China  
 ‘Has Jan sent Marie this postcard from China?’

The examples in (18) show that an *adverbial phrase* in the form of a *PP* or a *clause* can also occur in a *postverbal position*. Observe that *°clause adverbial phrases* differ from *clausal complements* in that they may occur both *pre-* and *postverbally*.

- (18) a. Jan is <nadat hij gesproken had> snel vertrokken <nadat hij gesproken had>.  
 Jan is after he spoken had soon left  
 ‘Jan left soon after he had addressed the meeting.’  
 b. Jan is <na de vergadering> snel vertrokken <na de vergadering>.  
 Jan is after the meeting soon left  
 ‘Jan left quickly after the meeting.’



The postverbal field is normally occupied by PPs and clauses, but this does not exhaust the possibilities: some adverbs may also occur postverbally. This is illustrated in (19a) for the modal adverb *waarschijnlijk* ‘probably’.

- (19) a. Jan zal dat boek <waarschijnlijk> graag lezen <waarschijnlijk>.  
 Jan will that book probably gladly read  
 ‘Jan will probably be eager to read that book.’

Adverbial phrases indicating manner are special in that they categorically resist postverbal placement; the examples in (20) show that this holds not only for the manner adverbs but also for adverbial phrases in the form of a PP.

- (20) a. Jan zal dat boek <aandachtig> lezen <\*aandachtig>.  
 Jan will that book attentively read  
 ‘Jan will read that book closely.’  
 b. Jan zal dat boek <met aandacht> lezen <?\*met aandacht>.  
 Jan will that book with attention read  
 ‘Jan will read that book closely.’

Observe that the examples in (21) show that the ungrammatical orders in (20) improve considerably if the postverbal phrases are preceded by an intonation break and assigned emphatic focus. In such cases the adverbials function as AFTERTHOUGHTS, which are often taken to be external to the main clause, and thus belong to the class of elements to be discussed in Chapter 14.

- (21) a. Jan zal dat boek lezen, ... AANDACHTIG.  
 Jan will that book read attentively  
 ‘Jan will read that book— closely.’  
 b. Jan zal dat boek lezen, ... met AANDACHT.  
 Jan will that book read with attention  
 ‘Jan will read that book—with care.’

The area between the verbs in second and clause-final position is often referred to as the MIDDLE FIELD of the clause. This part of the clause may contain virtually all constituent parts of the clause, with the notable exception of clausal arguments; see (16a) above.

## II. Embedded clauses

The most conspicuous property of main clauses is that they usually require their finite verb to occur in second position; the examples in (22) show that the embedded counterparts of the main clauses in (14) require that the finite verb be placed in clause-final position, just like the non-finite verbs.

- (22) a. Peter zei [dat Jan Marie dit boek heeft<sub>finite</sub> toegestuurd<sub>part</sub> vanuit China].  
 Peter said that Jan Marie this book has prt.-sent from China  
 ‘Peter said that Jan has sent Marie this book from China.’  
 b. Peter zei [dat Jan Marie dit boek wilde<sub>finite</sub> toesturen<sub>inf</sub> vanuit China].  
 Peter said that Jan Marie this book wanted prt.-sent from China  
 ‘Peter said that Jan wanted to send Marie this book from China.’



- c. Peter zei [dat Jan Marie dit boek toestuurde<sub>finite</sub> vanuit China].  
 Peter said that Jan Marie this book prt.-sent from China  
 ‘Peter said that Jan sent Marie this book from China.’

This means that generally the examples in (14) cannot be embedded as such; examples such as (23) can only be interpreted as direct/quoted speech. That these examples cannot be interpreted as involving indirect speech is not a trivial fact given that this is possible in German and, to a lesser extent, the eastern part of the Netherlands; cf. Haider (1985/2010) and Barbiers (2005: Section 1.3.1.8).

- (23) a. #Peter zei [Jan heeft<sub>finite</sub> Marie dit boek toegestuurd<sub>part</sub> vanuit China].  
 Peter said Jan has Marie this book prt.-sent from China  
 b. #Peter zei [Jan wilde<sub>finite</sub> Marie dit boek toesturen<sub>inf</sub> vanuit China].  
 Peter said Jan wanted Marie this book prt.-sent from China  
 c. #Peter zei [Jan stuurde<sub>finite</sub> Marie dit boek toe vanuit China].  
 Peter said Jan sent Marie this book prt. from China

The examples in (24) show that the cases in (23) do not improve when we add the complementizer *dat* ‘that’. Again, this is not a trivial fact given that this is the natural way of forming embedded declarative clauses in, e.g., English; cf. *John said that John has sent Mary the book from China*.

- (24) a. \*Peter zei [dat Jan heeft<sub>finite</sub> Marie dit boek toegestuurd<sub>part</sub> vanuit China].  
 Peter said that Jan has Marie this book prt.-sent from China  
 b. \*Peter zei [dat Jan wilde<sub>finite</sub> Marie dit boek toesturen<sub>inf</sub> vanuit China].  
 Peter said that Jan wanted Marie this book prt.-sent from China  
 c. \*Peter zei [dat Jan stuurde<sub>finite</sub> Marie dit boek toe vanuit China].  
 Peter said that Jan sent Marie this book prt. from China

The requirement that the verb be clause-final is, however, not absolute; there are a number of adverbial clauses that do allow the verb in first/second position. The examples in (25), for instance, show that conditional clauses may be introduced by the complementizer-like element *als* ‘if’ and have the finite verb in clause-final position, but they may also occur without *als* and then have the finite verb in first position. Exceptional cases like these are discussed in Section 10.3.

- (25) a. Als hij niet komt, dan krijgt hij niets.  
 if he not comes then gets he nothing  
 ‘If he doesn’t come, he won’t get anything.’  
 b. Komt hij niet, dan krijgt hij niets.  
 comes he not then gets he nothing  
 ‘If he doesn’t come, he won’t get anything.’

### III. *The standard analysis*

The two subsections above have shown that main and embedded clauses differ in the position of finite verbs: they appear in second position in main clauses but in clause-final position in embedded clauses. The current standard analysis relates this difference to the distribution of complementizers: these are normally excluded in main but obligatory in embedded clauses. Paardekooper (1961) has shown that

complementizers in embedded clauses and finite verbs in main clauses are placed in the same position with respect to pronominal subjects. When we put subject-initial main clauses aside for the moment, the examples in (26) show that such subject pronouns are always right-adjacent to the finite verb in main clauses and the complementizer in embedded clauses.

- (26) a. Gisteren was ik/je/hij voor zaken in Utrecht. [main clause]  
 yesterday was I/you/he on business in Utrecht  
 ‘Yesterday, I was/you were/he was in Utrecht on business.’  
 a’. \*Gisteren was voor zaken ik/je/hij in Utrecht.  
 b. dat ik/je/hij voor zaken in Utrecht was. [embedded clause]  
 that I/you/he on business in Utrecht was  
 ‘that I was/you were/he was in Utrecht on business.’  
 b’. \*dat voor zaken ik/je/hij in Utrecht was.

Paardekooper concludes from this that finite verbs in main clauses occupy the same position as complementizers in embedded clauses. He suggests that this similarity of placement is related to the fact that complementizers and finite verbs enter into a similar relationship with the subject of the clause, as is clear from the fact that in certain Dutch dialects (but not in Standard Dutch) complementizers and finite verbs may agree in number and person with the subject of the clause. Paardekooper illustrates this by means of the two examples in (27) taken from Van Haeringen (1939). Note that the complementizer *as* ‘when’ in these examples introduces temporal adverbial clauses, but that we find similar agreement in complement clauses introduced by the declarative complementizer *dat* ‘that’ or the interrogative complementizer *of* ‘whether’; see Haegeman (1992), Hoekstra & Smit (1997), Zwart (1997) and the references given there for examples and more information.

- (27) a.  $As_{sg}$  Wim  $komp_{sg}$ , mot jə zorgə dat je tuis ben.  
 when Wim comes must you make.sure that you at.home are  
 ‘When Wim comes, you must make sure to be at home.’  
 b.  $Azzə_{pl}$  Kees en Wim  $kommə_{pl}$ , mot jə zorgə dat je tuis ben.  
 when Kees and Wim come must you make.sure that you home are  
 ‘When Kees and Wim come, you must make sure to be at home.’

Paardekooper did not discuss the relation between the two positions of the finite verb in main and embedded clauses. The nature of this relation became, however, an urgent matter in early transformational grammar, in which it was assumed that the surface representations of sentences are transformationally derived from more abstract underlying forms. The main issue was: which word order is more basic—the one in main clauses or the one in embedded clauses? Koster (1975) convincingly argued that the order found in embedded clauses is more basic, on the basis of the following economy argument. If we assume that all verbs are base-generated in clause-final position, we only need a single VERB-SECOND rule that operates in main clauses and places the finite verb in second position: the rule in (28) simply expresses that finite verbs can be placed in second position in main clauses (X, Y and Z simply stand for a non-specified string of elements).

(28) • Verb-second (main clauses only)

$$\begin{array}{ccccc} X & & Y & V_{\text{finite}} & Z \Rightarrow \\ X & V_{\text{finite}} & Y & & Z \end{array}$$

If we assumed that verbs are all generated in second position, however, we would need at least two rules: (i) one rule that places all non-finite verbs in clause-final position and (ii) another rule that places the finite verb in clause-final position in embedded clauses. In fact, Koster (1975) argues that we need many more word order rules on this assumption, but we refer the interested reader to Koster’s classic article or to Zwart (2011: part II) for a more detailed technical introduction.

Building on Paardekooper’s insight, Den Besten (1983) added to Koster’s economy argument the claim that the verb-second rule can be formulated in such a way that we can appeal to positions independently needed by assuming that the finite verb moves into the position normally occupied by the complementizer in embedded clauses; cf. Emonds’ (1976) STRUCTURE PRESERVATION CONSTRAINT. The difference between main and embedded clauses is depicted in (29) on the basis of the structure proposed in (10). Note in passing that it is often assumed that head movement cannot skip intervening heads like T or X (but moves through them in a successive cyclic way); we have ignored this here but we will briefly return to it in Section 9.3.

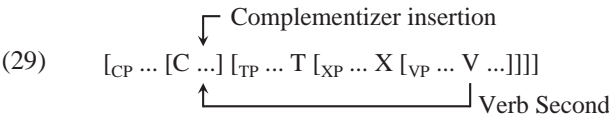

If we take the examples in (26) to show that subject pronouns obligatorily occupy the specifier of TP, that is the position left-adjacent to the T-head, this combination of the findings by Paardekooper and Koster provides a simple formal account of the basic Standard Dutch facts discussed so far.

*IV. Conclusion*

This section has briefly discussed the placement of the verbs in main and embedded clauses. We have seen that verbs are normally placed in clause-final position with the exception of finite verbs in main clauses, which occur in second position. We argued that this second position is the same position as the position occupied by complementizers in embedded clauses. By means of the verb positions V and C, we can divide the clause into three parts, as indicated in Figure (30). Sections 9.3 to 9.5 will discuss these parts in more detail.

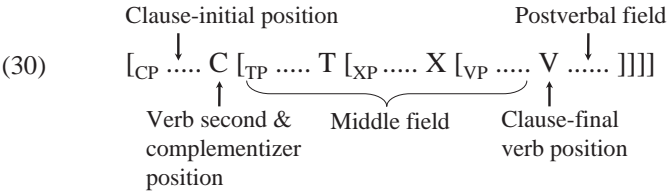

### 9.3. The clause-initial position

Section 9.2 has shown that finite verbs occupy the second position in main clauses, that is, that they can be preceded by at most one constituent. This constituent can be the subject of the clause or a topicalized phrase in declarative clauses, or a *wh*-phrase in interrogative clauses.

- (31) a. Mijn zuster heeft dit boek gelezen. [subject]  
 my sister has this book read  
 ‘My sister has read this book.’  
 b. Dit boek heeft mijn zuster gelezen. [topicalization]  
 this book has my sister read  
 ‘This book, my sister has read.’  
 c. Welk boek heeft mijn zuster gelezen? [wh-movement]  
 which book has my sister read  
 ‘Which book has my sister read?’

The standard generative analysis of examples such as (31) is that they all involve movement of some constituent from a clause-internal position into the specifier of CP, that is, the position preceding the finite verb in the C-position in the structure in (32). By assuming that specifier positions of any projection (that is, the positions to the immediate left of the heads C, T, X and V) can contain at most one constituent, we derive the verb-second effect.

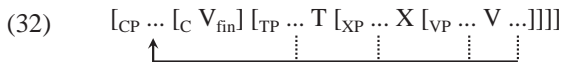

The following subsections will briefly discuss the three construction types in (31) both in main and in embedded clauses. This discussion will lead to a slightly revised version of the proposal in (32).

#### 1. *Wh*-movement

There are two types of questions: so-called *yes/no*-questions such as (33a), which request the addressee to provide the speaker with information about the truth of the proposition expressed by the clause, and *wh*-questions such as (33b), which request the addressee to provide the speaker with some piece of missing information related to the proposition. The clause-initial position of *yes/no*-questions remains phonetically empty (although it is perhaps lexically filled by a phonetically empty question operator). In *wh*-questions, the *wh*-phrase is normally moved into clause-initial position.

- (33) • Main clauses  
 a. Heeft mijn zuster dit boek gelezen? [yes/no-question]  
 has my sister this book read  
 ‘Has my sister read this book?’  
 b. Wanneer heeft mijn zuster dit boek gelezen? [wh-question]  
 when has my sister this book read  
 ‘When did my sister read this book?’

The hypothesis in (32), that the *wh*-phrase is moved into the specifier of CP, leads to the prediction that *wh*-phrases also precede the C-position in embedded questions. Although in the more formal registers complementizers are normally not phonetically realized in embedded *wh*-questions, it is easily possible to do so in colloquial speech. Example (34a) first shows that embedded *yes/no*-questions differ from embedded declarative clauses in that the complementizer does not have the form *dat* ‘that’ but the form *of* ‘whether’. The (b)-examples in (34) show that this complementizer can be optionally realized in embedded *wh*-questions, and must then follow the *wh*-phrase in clause-initial position; see Barbiers (2005: Section 1.3.1.5), where it is also shown that in some regions *of* finds an alternative realization as *of dat* or *dat*; see also Hoekstra & Zwart (1994), Sturm (1996) and Zwart & Hoekstra (1997) on the question as to whether *of dat* should be analyzed as a compound or as two separate words.

- (34) • Embedded clauses
- a. Jan vroeg [<sub>CP</sub> of [<sub>TP</sub> mijn zuster dit boek gelezen heeft]]. [yes/no]  
 Jan asked COMP my sister this book read has  
 ‘Jan asked whether my sister has read this book.’
- b. Jan vroeg [<sub>CP</sub> wie<sub>i</sub> (of) [<sub>TP</sub> t<sub>i</sub> dit boek gelezen heeft]]. [wh-question]  
 Jan asked who COMP this book read has  
 ‘Jan asked who has read this book.’
- b’. Jan vroeg [<sub>CP</sub> wat<sub>i</sub> (of) [<sub>TP</sub> mijn zuster t<sub>i</sub> gelezen heeft]]. [wh-question]  
 Jan asked what COMP my sister read has  
 ‘Jan asked what my sister has read.’

Example (35a) shows that *wh*-movement need not necessarily target the clause-initial position of the embedded clause, but that it is also possible to move a *wh*-phrase from the embedded clause into the clause-initial position of the sentence; we will refer to this as LONG *WH*-MOVEMENT. This is excluded, however, if the embedded clause is itself an embedded question: examples (35b&c) show that both *yes/no*- and *wh*-questions constitute a so-called ‘island’ for *wh*-extraction from the embedded clause; note that some (but not all) speakers report a slight acceptability contrast between the two examples in that (35b) is slightly less degraded than (35c).

- (35) • Long *wh*-movement
- a. Wat<sub>i</sub> denk je [dat mijn zuster t<sub>i</sub> gelezen heeft]?  
 what think you COMP my sister read has  
 ‘What do you think that my sister has read?’
- b. \*Wat<sub>i</sub> vroeg Jan [of mijn zuster t<sub>i</sub> gelezen heeft]?  
 what asked Jan COMP my sister read has
- c. \*Wat<sub>j</sub> vroeg Jan [<sub>CP</sub> wie<sub>i</sub> (of) [<sub>TP</sub> t<sub>i</sub> t<sub>j</sub> gelezen heeft]]?  
 what asked Jan who COMP read has

The examples in (35) are normally taken to show that *wh*-phrases originating in embedded clauses cannot be moved into the sentence-initial position in one fell swoop; they can only be extracted from embedded clauses via the specifier position of the embedded CP, which thus functions as an ‘escape hatch’. As a result, ‘long’ movement can be reinterpreted as a series of movements that apply in a

local/clause-bound fashion; cf. the schematic representation in (36), and Chomsky (1977) for detailed discussion. The claim is that this escape hatch is only available when the embedded clause is declarative: the position must be filled syntactically by a phonetically empty question operator (or perhaps remain empty) in *yes/no*-questions and be filled by some other interrogative phrase in *wh*-questions.



Since this will become relevant in the following subsections, we note here that Dutch shows a marked difference from English in that it allows subjects to be extracted from embedded clauses introduced by a complementizer; cf. Bennis (1986:ch.3). This is illustrated in (37). If the whole embedded clause expresses new information, as in (37a), subject extraction normally requires the presence of the °expletive element *er*; this expletive is optional when the embedded clause contains some presupposed phrase, as *dit boek* ‘this book’ in (37b), and gives rise to a degraded result when the presupposed phrase is pronominal, as *het* ‘it’ in (37c).

- (37) a. *Wie<sub>i</sub> denk je [dat er t<sub>i</sub> komt]?*  
 who think you that there comes  
 ‘Who do you think (\*that) is coming?’
- b. *Wie<sub>i</sub> denk je [dat (er) t<sub>i</sub> dit boek gelezen heeft].*  
 who think you that there this book read has  
 ‘Who do you think (\*that) has read this book?’
- c. *Wie<sub>i</sub> denk je [dat (\*er) t<sub>i</sub> het gelezen heeft].*  
 who think you that there it read has  
 ‘Who do you think (\*that) has read this book?’

## II. Topicalization

Topicalization is typically restricted to main clauses in Standard Dutch. The examples in (38) show that it is excluded in embedded clauses, regardless of whether the complementizer is phonetically realized or whether the topicalized phrase precedes or follows the declarative complementizer.

- (38) a. \**Jan zei [CP dit boek<sub>i</sub> (dat) [mijn zuster t<sub>i</sub> gelezen had]].*  
 Jan said this book COMP my sister read has
- b. \**Jan zei [CP (dat) dit boek<sub>i</sub> mijn zuster t<sub>i</sub> gelezen had]].*  
 Jan said COMP this book my sister read had

That topicalization is not possible in embedded clauses in Standard Dutch is clearly related to the fact that it does not allow embedded verb-second: German, as well as a large subset of the Dutch varieties that do allow embedded verb-second, also allows embedded topicalization: see Haider (1985/2010) for German and Barbiers (2005: Section 1.3.1.8) for the relevant non-standard Dutch varieties. Note in passing that Dutch topicalization seems rather different from English topicalization, which can give rise to English examples of the type in (38b): cf. *I believe that this book you should read*, taken from Lasnik & Saito (1992:76).

The cases in (39) show that, although topicalization is not possible within embedded clauses, it is possible to topicalize constituents from embedded clauses by placing them into sentence-initial position. The fact that example (39a) is possible (although perhaps somewhat marked) shows again that subjects can be extracted from embedded declarative clauses introduced by a complementizer.

- (39) a. Mijn zuster<sub>i</sub> zei Jan [dat t<sub>i</sub> dit boek gelezen had].  
       my sister said Jan COMP this book read had
- b. Dit boek<sub>i</sub> zei Jan [dat mijn zuster t<sub>i</sub> gelezen had].  
       this book said Jan that my sister read has

The examples in (40) show that topicalization is impossible if the embedded clause is interrogative; this suggests that, just as in the case of *wh*-movement, topicalization of some element from the embedded clause into sentence-initial position must proceed via the specifier position of the embedded CP; cf. the schematic representation in (36).

- (40) a. \*Mijn zuster<sub>i</sub> vroeg Jan zich af [welk boek<sub>j</sub> (of) t<sub>i</sub> t<sub>j</sub> gelezen had].  
       my sister wondered Jan REFL prt. which book COMP read had
- b. \*Dit boek<sub>j</sub> vroeg Jan zich af [wie<sub>i</sub> (of) t<sub>i</sub> t<sub>j</sub> gelezen had].  
       this book wondered Jan REFL prt. who COMP read has

*III. The position of the subject*

The representation in (41b) sketches the standard generative analysis of subject-initial declarative main clauses such as (41a). First, it is assumed that the specifier position of TP is the canonical subject position; it is the position where the subject is traditionally taken to be assigned °nominative case by the feature [+FINITE] of T. Second, since verb-second places the finite verb in C and C precedes the regular subject position, the subject must be topicalized into the specifier of CP in order to precede the finite verb.

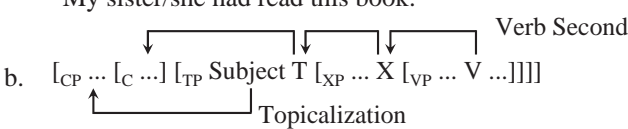
- (41) a. Mijn zuster/Zij/Ze had dit boek gelezen.  
       my sister/she/she had this book read  
       ‘My sister/she had read this book.’
- b. 

Note in passing that we accept the widely supported claim (from Travis 1984:131) that the verb moves to C via all intermediate head positions, for which reason we will from now on speak of V-to-C, V-to-T, V-to-X, etc. Verb movement via the intermediate T-position is generally motivated by stating that this movement can be triggered by the tense and/or agreement features in this position. The movement of the verb via the (as yet undetermined) X-position depicted in (41b) is provided for theory-internal reasons but need not concern us now; for this reason we will not include this movement in the representations in Subsection IV; the availability of V-to-C, however, will become crucial in the discussion given there.



If the derivation in (41) is correct, we would expect the placement of subjects to be subject to similar restrictions as regular topicalization. At first sight, this expectation seems to be borne out, given that Subsection II has already shown that embedded subjects like *mijn zuster* ‘my sister’ may be placed in sentence-initial position; cf. (42a). However, this cannot be an across-the-board conclusion as weak pronominal subjects show a conspicuously different behavior; the examples in (42b&c) show that, although topicalization of embedded subject pronouns seems possible if they are strong (that is, phonetically non-reduced) and contrastively stressed, it is clearly excluded when they are weak (phonetically reduced).

- (42) a. *Mijn zuster<sub>i</sub> zei Jan [dat t<sub>i</sub> dit boek gelezen had].*  
 my sister said Jan COMP this book read had  
 b. <sup>(?)</sup>*ZIJ<sub>i</sub> zei Jan [dat t<sub>i</sub> dit boek gelezen had].*  
 she said Jan COMP this book read had  
 c. *\*Ze<sub>i</sub> zei Jan [dat t<sub>i</sub> dit boek gelezen had].*  
 she said Jan COMP this book read had

The topicalization behavior of subject pronouns thus strongly resembles that of object pronouns: whereas strong object pronouns do allow topicalization when they are contrastively stressed, weak object pronouns do not; cf. Huybregts (1991).

- (43) a. *Marie/Ze heeft Peter/hem/'m gekust.*  
 Marie/she has Peter/him/him kissed  
 b. *PETER/HEM/\*'m heeft Marie/ze t<sub>i</sub> gekust.*  
 him/him/him has Marie/she kissed

Since example (41a) has shown that weak subject pronouns of main clauses are perfectly acceptable in sentence-initial position, the discussion above suggests that the topicalization approach to subject-initial clauses cannot be (fully) correct; let us consider an alternative approach in the following subsection.

IV. An alternative analysis

The previous subsections have shown that the different types of sentence-initial elements in main clauses exhibit different syntactic behavior when extraction from embedded clausal complements is taken into account. The main findings are summarized in Table (44); this subsection especially focuses on the fact that subjects can only be extracted from embedded clauses and placed in sentence-initial position if they are non-pronominal or contrastively stressed; weak embedded subject pronouns do not occur sentence-initially.

(44) The syntactic distribution of interrogative, topicalized and subject phrases

	SENTENCE-INITIAL	EMBEDDED CLAUSES	
		EXTRACTION	CLAUSE-INITIAL
INTERROGATIVE PHRASES	+	+	+
TOPICALIZED PHRASES	+	+	—
SUBJECTS	+	non-pronominal: + stressed pronouns: <sup>(?)</sup> weak pronouns: —	—



Table (44) strongly suggests that the standard assumption that subject-initial sentences are derived by means of topicalization of the subject, as in (41), is not correct. However, if we adopt the structure in (10), repeated in a somewhat revised form in (45), we can readily account for the difference in extraction behavior of pronominal subjects on the one hand, and interrogative and topicalized phrases on the other, by assuming that subject-initial sentences are not CPs but TPs (which is the traditional standard assumption for English).

$$(45) \quad [_{CP} \dots C [_{TP} \text{ Subject T } [_{XP} \dots X [_{VP} \dots V \dots]]]]$$

The verb-second property of Dutch can then be derived by assuming the analyses in (46); cf. Travis (1984) and Zwart (1997). The V-to-T movement in the subject-initial sentence in (46a) can be motivated by appealing to the earlier assumption that T contains the tense and/or agreement features of the verb. The subsequent T-to-C movement of the verb into the C-position in (46b) can be motivated by assuming that C contains certain illocutionary features. By assuming that declarative force is assigned as a default value, the absence of the CP-layer in subject-initial clauses such as (46a) can also be accounted for.

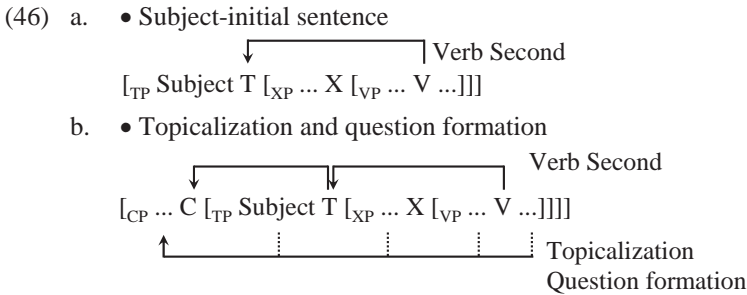

Obviously, the analysis in (46) raises the question as to why the verb does not move to T in embedded clauses, thus giving rise to a word order (found in English) in which the subject is sandwiched between the complementizer and the finite verb: *\*dat mijn broer heeft dit boek gelezen*. The assumption that verb movement is forced by the language-specific surface condition that the *highest* functional head in an extended projection must be lexically filled would solve this. It predicts that when the C-position is filled by the complementizer, the verb can remain in its original position within the lexical domain. If this assumption is acceptable, verb movement can be functionally motivated by saying that each clause must be marked as such by a complementizer or a finite verb in second position. Since further discussion would take us into theory-internal argumentation, we will not elaborate here but refer the reader to Zwart (2001) and Broekhuis (2008: Section 4.1) for further discussion.

We should point out, however, that accepting the two structures in (46) would make it possible to account for the contrast in verbal inflection in the examples in (47) by making the form of the finite verb sensitive to the position it occupies; if the verb is in T, as in (47a), second person singular agreement is realized by means of a *-t* ending, but if it is in C, as in (47b&c), it is realized by means of a null morpheme.

- (47) a. Jij/Je loop-t niet erg snel.  
 you/you walk-2sg not very fast  
 ‘You don’t walk very fast.’
- b. Erg snel loop-Ø jij/je niet.  
 very fast walk-2sg you/you not  
 ‘You don’t walk very fast.’
- c. Hoe snel loop-Ø jij/je?  
 how fast walk-2sg you/you  
 ‘How fast do you walk?’

Given that Dutch exhibits morphological alternations like these with second-person singular subjects only, we will not digress on this point here, but refer the reader to Zwart (1997), Postma (2011) and Barbiers (2013) for a discussion of language varieties which more generally exhibit similar contrasts in inflection.

### V. Conclusion

This section has discussed the clause-initial position, which can be filled by means of topicalization and *wh*-movement. The two movement types differ, however, in that topicalization always targets the sentence-initial position, whereas *wh*-movement may also target the initial position of embedded clauses. Traditionally, subject-initial main clauses are also analyzed as topicalization constructions; the verb is moved into the C-position of the clause and the subject must therefore be subsequently moved into the specifier of CP. The fact that topicalization of weak (phonetically reduced) pronouns is normally not possible sheds doubt on this view, given that weak subject pronouns can readily occur sentence-initially, thus giving rise to the claim that subject-initial main clauses can be TPs.

#### 9.4. The postverbal field

The postverbal field differs from the clause-initial position in that it does *not* consist of a unique, single position: it can readily contain more than one constituent of the clause. This is illustrated in the examples in (48), taken from Koster (1974); in (48a) all constituents precede the clause-final verb, in (48b&c) the verb is followed by a single constituent, while in (48d) it is followed by two constituents. The examples in (48) also show that the phrases in the postverbal field can be of various types: the PP *aan zijn vader* is a PP-complement of the verb whereas the PP *tijdens de pauze* is an adverbial modifier of time. Nevertheless, it is not the case that all arguments and adverbial phrases can be placed in the postverbal field; one of the goals of this section is to establish a number of restrictions on this option.

- (48) a. dat Jan tijdens de pauze aan zijn vader dacht.  
 that Jan during the break of his father thought  
 ‘that Jan was thinking of his father during the break.’
- b. dat Jan tijdens de pauze dacht aan zijn vader.
- c. dat Jan aan zijn vader dacht tijdens de pauze.
- d. dat Jan dacht aan zijn vader tijdens de pauze.

The discussion in this section is organized as follows. Subsection I starts with a discussion of the placement of the arguments of the verb, and show that their ability to occur postverbally depends on their categorial status: nominal complements normally precede, complement clauses normally follow, and PP-complements can normally either precede or follow the clause-final verb(s). Subsection II discusses the restrictions on the distribution of adverbial phrases; it will show that various types of adverbial phrases can occur either pre- or postverbally, with the notable exception of manner adverbs, which must precede the clause-final verb(s). Subsection III will show that the postverbal field may contain not only entire clausal constituents, but also subparts of such constituents, like relative clauses or PP-modifiers of nominal arguments.

### *I. Arguments of the verb*

The examples in (49a&b) show that nominal arguments differ from clausal arguments in that the former normally precede the clause-final verb(s), whereas the latter follow them. PP-complements differ from nominal and clausal arguments in that they normally may either precede or follow the clause-final verb(s).

- (49) a. dat Jan hem <het verhaal> vertelde <\*het verhaal>. [nominal compl.]  
 that Jan him the story told  
 ‘that Jan told him the story.’
- b. dat Jan hem <\*dat zij komt> vertelde <dat zij komt>. [clausal compl.]  
 that Jan him that she comes told  
 ‘that Jan told him that she’ll come.’
- c. dat Jan hem <over haar komst> vertelde <over haar komst>. [PP-compl.]  
 that Jan him about her arrival told  
 ‘that Jan told him about her arrival.’

Subsection A discusses the contrast between nominal and clausal complements while subsection B continues with a discussion of the placement of PP-complements. Subsection C is comparative and more theoretical in nature; it deals briefly with the placement of the same types of arguments in English in order to show that our findings for Dutch may reflect some more general property of (at least) the Germanic languages.

#### *A. Nominal versus clausal complements*

The placement differences of nominal and clausal complements relative to the clause-final verb(s) illustrated in (49a&b) have been a focus of attention ever since the rise of early generative grammar. The assumption that direct objects are inserted in the complement position of the verb inevitably led to the conclusion that alternate placements of direct objects in the sentence are the result of some movement transformation. So the question arose what the base-position of the direct object is: that of the nominal complement in (49a) or that of the clausal complement in (49b)? The consensus on this question in the mid 1970s seemed to be that underlyingly Dutch is an OV-language and that objects must therefore be uniformly base-generated in preverbal position; examples such as (49b) are thus derived by means

of an obligatory EXTRAPOSITION rule, which moves the clause from the preverbal object position into some postverbal position; cf. Koster (1973/1974/1975).

Although the extraposition approach remained dominant until the mid 1990s, it was clear from the start that it was not without its problems; cf. De Haan (1979). The most conspicuous problem had to do with °freezing: since extraposition is movement and movement normally gives rise to a freezing effect, the extraposition approach predicts that clausal complements are islands for extraction; however, the sentence in (50), in which *wh*-movement takes place from an embedded clause, shows that this prediction is incorrect.

- (50) Welk boek<sub>i</sub> heeft Jan gezegd [dat mijn zuster t<sub>i</sub> gelezen heeft]<sub>i</sub>?  
 which book has Jan said COMP my sister read has  
 ‘Which book has Jan said that my sister has read?’

One potential way of saving the assumption that Dutch is underlyingly an OV-language and thus requires the direct object to be base-generated in preverbal position is to assume that the postverbal clause is actually not the true object of the verb but that it is dependent on a phonetically empty anticipatory object pronoun comparable to *het* in (51a), in which we indicate the relation between the pronoun and the clause by means of indices; see Koster (1999) for a defense of this analysis. However, this analysis is generally rejected because (51b) shows that the presence of an overt °anticipatory pronoun normally blocks *wh*-movement from the embedded clause; see Hoekstra (1983), Bennis (1986), and many others. Note that we have added the particle *nog* in these examples, since some speakers seem to prefer some material between the anticipatory pronoun and the clause-final verb.

- (51) a. dat Jan het<sub>i</sub> (nog) zei [dat mijn zuster dat boek gelezen heeft]<sub>i</sub>.  
 that Jan it PRT said that my sister that book read has  
 ‘that Jan said it that my sister has read that book.’  
 b. \*Welk boek<sub>i</sub> heeft Jan het<sub>i</sub> (nog) gezegd [dat mijn zuster t<sub>i</sub> gelezen heeft]<sub>i</sub>?  
 which book has Jan it PRT said that my sister read has  
 Intended reading: ‘Which book has Jan said that my sister has read?’

If we continue assuming that nominal and clausal objects are base-generated in the same position, the obvious alternative to explore is to assume that they are both base-generated in postverbal position and that the nominal object is moved into some preverbal position. This approach has become popular since Kayne (1994), in which it was argued that rightward movement is excluded on general grounds, and that movement is thus uniformly to the left. A virtue of this approach is that we know independently that noun phrases may raise to higher/more leftward positions; for example, it is standardly assumed that the subject of a passive sentence is raised from the position occupied by the direct object of the corresponding active clause into the regular subject position of the clause, as in (52b), in order to get °nominative case and/or to establish agreement with the finite verb.

- (52) a. dat Jan Marie het boek aanbood. [active]  
 that Jan Marie the book prt.- offered  
 ‘that Jan offered Marie the book.’
- b. dat het boek<sub>i</sub> Marie t<sub>i</sub> aangeboden werd. [passive]  
 that the book Marie prt.-offered was  
 ‘that the book was offered to Marie.’

In line with this tack, we might assume that the nominal object likewise moves from its underlying postverbal position into some higher position in which it can be assigned °accusative case or establish abstract (that is, phonetically invisible) object-verb agreement (which is morphologically expressed in many other languages). A potential problem for this proposal is that it wrongly predicts freezing of the nominal direct object; example (53a) shows that the phrase *wat voor een boek* ‘what kind of book’ functions as a single nominal phrase, which strongly suggests that (53b) is derived by extraction of the element *wat* from this complex phrase and thus that nominal objects are *not* islands for *wh*-extraction.

- (53) a. [Wat voor een boek]<sub>i</sub> heeft mijn zuster t<sub>i</sub> gelezen.  
 what kind of book has my sister read  
 ‘What kind of book did my sister read?’
- b. Wat<sub>i</sub> heeft mijn zuster [t<sub>i</sub> voor een boek] gelezen.

The discussion above shows that we can only maintain the assumption that nominal and clausal complements are base-generated in the same position if we assume that specific obligatory movement operations do not result in freezing; see Broekhuis (2008) for a proposal to that effect. It may, however, also be the case that the presupposition that nominal and clausal complements are base-generated in the same position is incorrect and that they are simply base-generated in, respectively, some pre- and postverbal position, as was proposed in De Haan (1979:44) and Barbiers (2000). A potential problem for this solution is that the verb and the postverbal clause should be considered a base-generated constituent, which leads to the wrong prediction that postverbal clauses must precede extraposed phrases, such as the PP *tegen Peter* ‘to Peter’ in (54).

- (54) a. dat Jan tegen Peter [zei [dat hij zou komen]].  
 that Jan to Peter said that he would come  
 ‘that Jan said to Peter that he would come.’
- b. ??dat Jan zei [dat hij zou komen] tegen Peter.  
 that Jan said that he would come to Peter
- b’. dat Jan zei tegen Peter [dat hij zou komen].  
 that Jan said to Peter that he would come

This subsection has briefly discussed three approaches to the placement of nominal and clausal arguments: two movement approaches (one involving rightward movement of clausal and one involving leftward movement of nominal arguments) and one base-generation approach. We have seen that they all rubn into various potential problems for which special provisions should be made.

## B. PP-complements

Subsection A has shown that nominal and clausal complements are strictly ordered with respect to the clause-final verb(s). This subsection shows that this does not hold for PP-complements, which can normally occur either to the left or to the right of these verbs.

- (55) a. dat Jan <over het probleem> nadacht < over het probleem >.  
 that Jan about the problem prt.-thought  
 'that Jan was thinking about the problem.'  
 b. dat Jan <op het telefoontje> wacht <op het telefoontje >.  
 that Jan for the phone.call waits  
 'that Jan is waiting for the phone call.'

In cases like these it seems easy to establish the base-position of the PP: assuming that the two positions are related by movement, we predict that the PP in the derived position will exhibit a freezing effect. The fact illustrated by the examples in (56) that °R-extraction is possible from the preverbal but not from the postverbal PP leads to the conclusion that the preverbal position is the more basic one; cf. Ruys (2008). This can be taken to support an OV-analysis of Dutch, provided we assume that PP-complements are base-generated in the complement position of the verb.

- (56) a. dat Jan *er* de hele dag <*aan*> dacht <°*aan*>  
 that Jan there the whole day about thought  
 'that Jan was thinking about it all day.'  
 b. dat Jan *er* de hele dag <*op*> wacht <°*op*>  
 that Jan there the whole day for waits  
 'that Jan was waiting for it all day.'

The conclusion that the postverbal placement of PP-complements is the result of an extraposition operation, which has become known as PP-OVER-V, seems virtually inescapable if one assumes that movement invariably gives rise to a freezing effect. However, there are also problems with the claim that the stranded prepositions in (56) occupy the complement position of the verb. First consider example (57a), which shows that so-called °VP-topicalization involves movement of a larger verb phrase that may include at least the direct object, that is, the complement position of the main verb. The earlier conclusion that stranded prepositions must occupy the base-position of the PP-complement therefore implies that the stranded preposition is VP-internal and must consequently be pied-piped by VP-topicalization. Example (57b') shows, however, that °pied piping gives rise to an ungrammatical result; cf. Den Besten & Webelhuth (1990).

- (57) a. [<sub>VP</sub> Dat boek lezen] wil Jan niet *t*<sub>i</sub>.  
 that book read wants Jan not  
 'Jan doesn't want to read that book.'  
 b. [<sub>VP</sub> wachten]<sub>i</sub> wil Jan *er* niet *op* *t*<sub>i</sub>.  
 wait wants Jan there not for  
 b'. \*[<sub>VP</sub> *op* wachten]<sub>i</sub> wil Jan *er* niet *t*<sub>i</sub>.  
 for wait want Jan there not

If we accept the freezing effect as a diagnostic for movement, the acceptability of (57b) suggests that PP-complements are not base-generated as a complement of the verb at all, but VP-externally. Analyses of this sort have indeed been proposed on independent grounds and amount to saying that extraposition of PPs does not result from rightward movement of the PP but from leftward movement of the VP into a position left-adjacent of the PP. An early proposal of this kind can be found in Barbiers (1995), who claims that the landing site of the VP is the specifier of the PP, and that this turns the PP into an island for extraction. A potential problem for this proposal is that PP-complements are not generated within the lexical projection of the verb, but this can be solved if we follow Kayne (2004), who claims that PP-complements of verbs are not inserted as a unit but derived in the course of the derivation; the preposition is inserted as a functional head, which attracts a nominal complement of the verb. We will not discuss these proposals in detail here, but confine ourselves to stating that it is not *a priori* evident whether PP-complements are base-generated to the left or to the right of the clause-final verb(s) and, perhaps even more surprising, that it is not even evident that they are base-generated in the complement position of the verb.

### C. A comparison with English

The early extraposition approach considers the clause-final verb(s) to be the pivot around which a number of syntactic processes take place. Complements are inserted in preverbal position and various category-specific movement rules lead to a reordering of the verb and its complements. Such rearrangements are excluded with nominal complements, obligatory with clausal complements, and optional with PP-complements. The central role attributed to the verb is very aptly expressed by the term PP-over-V in the case of extraposition of PPs. More recent research has shown, however, that the pivotal role of verbs is perhaps an incidental property of Dutch. This can be clarified with the help of the English examples in (58).

- (58) a. that John told the story yesterday.  
 b. \*that John told yesterday the story.  
 b'. \*that John said that he will come yesterday.  
 b''. that John said yesterday that he will come.  
 c. that John waited for his father a long time.  
 c'. that John waited a long time for his father.

Despite the fact that nominal, clausal, and prepositional complements all follow the main verb in English, it is clear that they exhibit a distributional difference similar to the corresponding elements in Dutch. The fact that clausal complements must follow time adverbs such as *yesterday*, whereas nominal complements normally precede such adverbs, shows that these complements occupy different positions. The fact that the PP-complement may either precede or follow the adverbial phrase *a long time* reflects the distributional behavior of the Dutch PP. The correspondence between the Dutch and English examples shows that what is at stake here is not so much the position of the complements relative to the verb but their *absolute* positions; in Dutch as well as in English, the three types of complements simply occupy different positions in the clause. An interesting hypothesis would be



therefore that Dutch and English behave identically when it comes to the placement of *the complements of the verb*, but differently when it comes to the placement of *the verb* itself. One implementation, which seems to be widely accepted by the current generation of generative grammarians, is the claim that the lexical domain of the clause is not just a simple projection of the verb V, as suggested by the representation in (10), repeated here as (59a), but consists of at least two projections: one headed by a root element, which is normally (somewhat misleadingly) represented by V, and another headed by a so-called light verb *v*, as indicated in (59b); cf. Chomsky (1995). Recall that X in this structure stands for an indeterminate number of functional heads that may be needed to provide a full description of the structure of the clause.

- (59) a. [CP ... C [TP ... T [XP ... X [VP ... V ...]]]]  
 b. [CP ... C [TP ... T [XP ... X [VP ... v [VP ... V ...]]]]]

The basic intuition behind the structure in (59b) is that all verbs are in fact derived from some non-verbal root by means of affixation with the verbal morpheme *v*. Although normally the light verb *v* is phonetically empty in Dutch, the hypothesis receives empirical support from Latinate verbs like *irriteren* ‘to irritate’: this verb can be taken to be derived from a non-verbal root *irrit-*, which can also be used as the input of the adjective *irritant* or the noun *irritatie*. The Dutch light verb *v* can thus be seen as a zero morpheme comparable to *-eren* in (60a).

- (60) a. [[irrit-]<sub>STEM</sub> -eren<sub>v</sub>] ‘to irritate’  
 b. [[irrit-]<sub>STEM</sub> -ant<sub>A</sub>] ‘irritating’  
 c. [[irrit-]<sub>STEM</sub> -atie<sub>N</sub>] ‘irritation’

The correspondences between Dutch and English can now be accounted for by assuming that in these languages nominal, clausal, and prepositional complements occupy the same surface positions in the clause, while the differences can be accounted for by assuming that the root V moves to (merges with) the light verb *v* in English but not in Dutch embedded clauses. This is shown for nominal and clausal complements in (61). The postulated difference in V-to-*v* movement between English and Dutch can in fact be held responsible for the fact that English surfaces as a VO-language, whereas Dutch surfaces as an OV-language; see Barbiers (2000) and Broekhuis (2008/2011) for discussion.

- (61) 
$$\begin{array}{c} \text{NP} \quad \text{Clause} \\ \downarrow \quad \downarrow \\ \dots [_{VP} \dots v [_{VP} \dots V \dots ] ] \\ \underbrace{\hspace{10em}} \\ \text{Lexical domain} \end{array}$$
- V-to-*v* parameter** (embedded clauses)  
 English: V-to-*v* compulsory  
 Dutch: V-to-*v* prohibited

Note in passing that the schematic representation in (61) is not intended to make any claim about the base-positions of nominal and clausal complements; it may well be that VP is in fact a larger constituent within which the nominal or the clausal complement has moved to its surface position; see Johnson (1991), Koizumi (1993) and Broekhuis (2008) for arguments in favor of leftward movement of nominal objects within this VP-domain.



*D. Conclusion*

This subsection has briefly discussed the distribution of postverbal arguments: nominal and clausal arguments occur, respectively, pre- and postverbally, while PP-complements may occur on either side of the clause-final verb(s). By adopting the claim that complements are all base-generated in the complement position of the verb, generative grammar has attempted to account for the different placement options by means of specific rearrangements in the clause. Early proposals involved obligatory extraposition of clausal arguments and optional PP-over-V. Since the mid-1990s, proposals have been developed that involve leftward movement of nominal complements and verbal projections. And there are also proposals that simply reject the claim that nominal and clausal arguments are base-generated in the same position. The debate concerning the derivation of the extant surface orders is ongoing and far from settled, and this subsection has reviewed only a small number of empirical facts that have played a crucial role in motivating/testing the various proposals. A more extensive description of the data can be found in Section 12.2.

*II. Adverbial modifiers*

It is often claimed that the postverbal field may contain not only prepositional and clausal complements of the verb, but also various types of adverbial phrases (although we will see in Section 12.3 that this claim has recently been challenged and may be in need of revision). If correct, it should be noted that the availability of this option is related to the function of the adverbial phrase: adverbial phrases that affect the denotation of the verb, like manner adverbs, must occur preverbally, whereas all other adverbial phrases may occur either pre- or postverbally in speech (with the postverbal position often being the stylistically marked one if the adverbial phrase is not a PP).

- (62) a. dat Jan het boek <grondig> las <\*grondig>. [manner]  
 that Jan the book thoroughly read  
 'that Jan read the book carefully.'
- b. dat Jan het boek <in de tuin> leest <in de tuin>. [locational]  
 that Jan the book in the garden reads  
 'that Jan is reading the book in the garden.'
- c. dat Jan het boek <verleden week> heeft gelezen <verleden week>. [time]  
 that Jan the book last week has read  
 'that Jan read the book last week.'
- d. dat Jan het boek <waarschijnlijk> zal lezen <waarschijnlijk>. [modal]  
 that Jan the book probably will read  
 'that Jan will probably read the book.'

The examples in (62) also show that postverbal adverbial phrases can be of several syntactic categories: example (62b) involves a prepositional phrase, example (62c) a nominal phrase, and (62d) an adjectival phrase. The fact that nominal adverbial phrases may occur postverbally shows that the obligatory preverbal placement of nominal arguments cannot be accounted for by assuming a general ban on postverbal nominal phrases (unless one would like to assume that these are in fact PPs with an empty preposition; see Larson 1985 and McCawley 1988 for discussion).

The instances in (63) show that it is not only nominal adverbial phrases that differ from nominal arguments, but that adverbial clauses likewise differ from clausal complements: unlike the latter, the former need not be in postverbal position but can also occur preverbally. It should be noted, however, that postverbal placement of adverbial clauses is often preferred for stylistic reasons, e.g., to avoid that the middle field becomes too long/complex.

- (63) a. dat Jan [voordat hij vertrok] iedereen een hand gaf.  
 that Jan before he left everybody a hand gave  
 ‘that Jan shook hands with everybody before he left.’  
 a’. dat Jan iedereen een hand gaf [voordat hij vertrok].  
 b. dat Jan [omdat hij ziek was] naar huis ging.  
 that Jan because he ill was to home went  
 ‘that Jan went home because he was ill.’  
 b’. dat Jan naar huis ging [omdat hij ziek was].

### III. Postverbal phrases that are not constituents of the clause

The postverbal field may not only contain arguments of the verb and adverbial modifiers, but also subparts of such constituents. This is illustrated in the primed examples in (64) by means of, respectively, a relative clause and a PP-modifier of the direct object.

- (64) a. Jan heeft [<sub>NP</sub> het boek [<sub>REL-CLAUSE</sub> dat Els hem gegeven heeft]] gelezen.  
 Jan has the book that Els him given has read  
 ‘Jan has read the book that Els gave him.’  
 a’. Jan heeft [<sub>NP</sub> het boek] gelezen [<sub>REL-CLAUSE</sub> dat Els hem gegeven heeft].  
 b. Jan heeft [<sub>NP</sub> het boek [<sub>PP</sub> met de gele kaft]] gelezen.  
 Jan has the book with the yellow cover read  
 ‘Jan has read the book with the yellow cover.’  
 b’. Jan heeft [<sub>NP</sub> het boek] gelezen [<sub>PP</sub> met de gele kaft].

The examples in (65) shows that this option is available not only for modifiers of complements of the verb but also for phrases that are more deeply embedded: in (65a) the postverbal relative clause modifies the noun phrase *het boek* ‘the book’, which is itself part of a PP-complement of the verb; in (65b) the postverbal PP functions as the PP-complement of the predicative AP *erg trots* preceding the verb; and in (65c) the postverbal relative clause modifies a noun phrase that is embedded in a PP-complement of this predicative AP.

- (65) a. dat Jan [<sub>PP</sub> op het boek] wacht [<sub>REL-CLAUSE</sub> dat Els hem toegestuurd heeft].  
 that Jan for the book waits that Els him prt.-sent has  
 ‘that Jan is waiting for the book that Els has sent him.’  
 b. dat Jan [<sub>AP</sub> erg trots] is [<sub>PP</sub> op zijn zoon]].  
 that Jan very proud is of his son  
 ‘that Jan is very proud of his son.’  
 c. Dat Jan [<sub>AP</sub> erg trots op het boek] is [<sub>REL-CLAUSE</sub> dat hij geschreven heeft]].  
 that Jan very proud of the book is that he written has  
 ‘that Jan is very proud of the book that he has written.’

If we assume that the postverbal phrase is generated as part of the preverbal nominal/adjectival phrase, there are again at least two possible analyses: one is that the larger phrase is base-generated preverbally and that the modifier/complement of this phrase is in extraposed position, and another is that the larger phrase is base-generated postverbally and that the modifier/complement of this phrase is stranded by leftward movement of this phrase. The first proposal is the one standardly adopted in early generative grammar; cf., e.g., Reinhart (1980) and Baltin (1983). The second one was first proposed by Vergnaud (1974) for relative clauses and has become quite popular since Kayne (1994); see also Bianchi (1999). An alternative approach, which is attractive in view of the depth of embedding of the modified phrases, is that the postverbal phrase has never been part of the preverbal phrase but is generated as an independent phrase; see Kaan (1992), Koster (2000), De Vries (2002:ch.7) and much subsequent work. We will take this issue up again in Section 12.4.

**9.5. The middle field**

This section briefly discusses the so-called middle field of the clause, that is, that part of the clause bounded to the right by the verb(s) in clause-final position (if present), and to the left by the complementizer in an embedded clause or the finite verb in a main clause. The middle field of the examples in (66) is in italics.

- (66) a. Gisteren heeft *Jan met plezier dat boek* gelezen.  
 yesterday has Jan with pleasure that book read  
 ‘Jan enjoyed reading that book yesterday.’
- b. Ik denk [dat *Jan met plezier dat boek* gelezen heeft].  
 I think that Jan with pleasure that book read has  
 ‘I think that Jan enjoyed reading that book.’

The middle field of a clause is not a constituent and not even a phrase, but refers to a set of positions within the clause. If we adopt the representation in (59b) and assume that C is the position of the complementizer or the finite verb in second position and that the clause-final verb occupies V, the middle field is as indicated in (67).

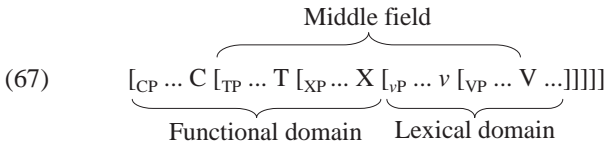

The fact that the middle field does not refer to a discrete entity in the clausal domain makes it clear immediately that we are dealing with a pre-theoretical notion. This is also evident from the fact that it refers to a slightly smaller domain in subject-initial sentences, such as *Jan heeft met plezier dat boek gelezen*, if such sentences are not CPs but TPs, as suggested by the data discussed in Section 9.3, sub IV.

- (68) a. Jan heeft *met plezier* *dat boek* gelezen.  
 Jan has with pleasure that book read

Middle field

- b.  $[_{TP} \text{ Subject T } [_{XP} \dots \text{ X } [_{VP} \dots v [_{VP} \dots \text{ V } \dots]]]]]$   
 Functional domain      Lexical domain

Recall that X in the structures in (67) and (68) stands for an indeterminate number of functional heads that may be needed to provide a full description of the structure of the clause. More specifically, just as the specifier of C may function as the landing site of *wh*-movement and topicalization, the lower functional heads may likewise introduce specifiers that can function as landing sites for several other types of movement.

- (69)  $[_{CP} \dots C [_{TP} \dots T [_{XP} \dots \text{ X } [_{VP} \dots v [_{VP} \dots \text{ V } \dots]]]]]$   
 ↑ Landing site for movement

Whether the postulation of such functional heads is indeed necessary or whether there are alternative ways of expressing the same theoretical intuition is a controversial matter, but it is evident that Dutch exhibits considerable freedom in word order (relative to many other languages) in the middle field of the clause. Example (70a), for instance, shows that a direct object can be left-adjacent to the verb(s) in clause-final position, but may also occur farther to the left. Similarly, example (70b) shows that the subject may be right-adjacent to the complementizer or finite verb in second position, but can also occur farther to the right.

- (70) a. dat Jan <het boek> waarschijnlijk <het boek> koopt.  
 that Jan the book probably buys  
 ‘that Jan will probably buy the book.’  
 b. dat <die jongen> waarschijnlijk <die jongen> het boek koopt.  
 that that boy probably the book buys  
 ‘that that boy will probably buy the book.’

The following subsections discuss a number of cases of word order variation in the middle field of the clause in terms of leftward movement without being too specific about the functional heads that may be involved (if any). We will show, however, that these movements may have semantic effects and/or may be related to certain semantic features of the moved elements. Before beginning with this, we want to make some remarks about a number of elements typically occurring at the right-hand edge of the middle field of the clause.

*1. Complementives and verbal particles*

Predicative complements (complementives) normally precede the clause-final verb(s), whatever their category, as shown in (73) for nominal, adjectival and prepositional complementives. This word order restriction is especially conspicuous in the case of predicative PPs like *op het bed* in (71c) given that PP-complementives normally can readily appear in postverbal position; cf. Section 9.4.

- (71) a. dat ik hem <een schat> vind <\*een schat>. [nominal]  
 that I him a dear consider  
 ‘that I believe him to be a darling.’
- b. dat Peter Marie <erg kwaad> maakt <\*erg kwaad>. [adjectival]  
 that Peter Marie very angry makes  
 ‘that Peter makes Marie very angry.’
- c. dat Jan zijn kleren <op het bed> gooit <\*op het bed>. [prepositional]  
 that Jan his clothes on the bed throws  
 ‘that Jan throws his clothes on the bed.’

Complementives can easily be moved into clause-initial position by topicalization or *wh*-movement, but in the middle field they normally occupy the position adjacent to the verb(s) in clause-final position, as illustrated in the examples in (72). We will see in Subsection IIID, however, that they may sometimes be moved to the left if they receive contrastive accent.

- (72) a. dat ik hem <\*een schat> nog steeds <een schat> vind. [nominal]  
 that I him a dear yet still consider  
 ‘that I still believe him to be a darling.’
- b. dat Peter Marie <\*erg kwaad> vaak <erg kwaad> maakt. [adjectival]  
 that Peter Marie very angry often makes  
 ‘that Peter often makes Marie very angry.’
- c. dat Jan zijn kleren <\*op het bed> meestal <op het bed> gooit. [prep.]  
 that Jan his clothes on the bed normally throws  
 ‘that Jan normally throws his clothes on the bed.’

The tendency of complementives to immediately precede the verb(s) in clause-final position makes it possible to use complementives as a diagnostic for extraposition. This is illustrated in (73) where we see that nominal arguments (here the SUBJECT of the complementives themselves) must precede the complementives, whereas clausal arguments must follow them, just as in the case of clause-final verbs.

- (73) a. Jan maakte <het probleem> duidelijk <\*het probleem>.  
 Jan made the problem clear  
 ‘Jan clarified the problem.’
- b. Jan maakte <\*dat het onmogelijk was> duidelijk <dat het onmogelijk was>.  
 Jan made that it impossible was clear  
 ‘Jan made it clear that it was impossible.’

Verbal particles are perhaps even more reliable indicators of extraposition. Like the complementives in the examples above, they are normally left-adjacent to the verb(s) in clause-final position, but unlike complementives they cannot be moved leftwards because it is normally not easy to assign them contrastive accent. The examples in (74) with the particle verb *afleiden* ‘to deduce from’ show that, in neutral sentences, the PP-complement may either precede or follow the particle, and that the particle follows nominal but precedes clausal complements. Again, this is precisely what we find with clause-final verbs; cf. Subsection I.

- (74) a. Els leidde *deze conclusie* <uit zijn weigering> af <uit zijn weigering>.  
 Els deduced this conclusion from his refusal prt.  
 ‘Els concluded this from his refusal.’
- b. Els leidde <uit zijn weigering> af <uit zijn weigering> *dat hij bang was*.  
 Els deduced from his refusal prt. that he scared was  
 ‘Els deduced from his refusal that he was scared.’

The examples in (73) and (74) show that in clauses without clause-final verbs complementives and verbal particles can be used as reliable indicators of the right boundary of the middle field.

## II. Nominal argument (object and subject) shift

Dutch allows a wide variety of word orders in the middle field of the clause. This subsection discusses the relative order of nominal arguments and °clausal adverbs like *waarschijnlijk* ‘probably’. All nominal arguments of the verb may either precede or follow such adverbs, which is illustrated in (75) by means of a subject and a direct object. The word order variation in (75) is not entirely free but restricted by information-structural considerations, more specifically, the division between presupposition (discourse-old information) and focus (discourse-new information); cf. Verhagen (1986).

- (75) a. dat waarschijnlijk Marie dat boek wil kopen.  
 that probably Marie that book wants buy  
 ‘that Marie probably wants to buy that book.’
- a'. dat Marie waarschijnlijk dat boek wil kopen.  
 that Marie probably that book wants buy  
 ‘that Marie probably wants to buy that book.’
- b. Marie heeft waarschijnlijk dat boek gekocht.  
 Marie has probably that book bought  
 ‘Marie has probably bought that book.’
- b'. Marie heeft dat boek waarschijnlijk gekocht.  
 Marie has that book probably bought  
 ‘Marie has probably bought that book.’

The distinction between presupposition and focus is especially clear in question-answer contexts, as we will illustrate below for the cases of object movement in the (b)-examples. A question like (76a) introduces the referent of *dat boek* as a topic of discussion, and therefore the answer preferably has the noun phrase in front of the adverb, that is, presents the noun phrase as discourse-old information; in actual speech, this is made even clearer by replacing the noun phrase *dat boek* by the personal pronoun *het*, which typically refers to discourse-old information.

- (76) a. Wat heeft Marie met dat boek gedaan? [question]  
 what has Marie with that book done
- b. ??Zij heeft waarschijnlijk dat boek gekocht. [answer = (75b)]  
 she has probably that book bought
- b'. Zij heeft dat boek waarschijnlijk gekocht. [answer = (75b')]  
 she has that book probably bought

A question like (77a), on the other hand, clearly does not presuppose the referent of the noun phrase *dat boek* to be a topic of discourse, and now the preferred answer has the noun phrase after the adverb. The answer in (77b') with the nominal object preceding the adverb is only possible if the context provides more information, e.g., if the participants in the discourse know that Marie had the choice between buying a specific book or a specific CD; in that case the nominal object preceding the adverb is likely to have contrastive accent.

- (77) a. Wat heeft Marie gekocht? [question]  
 what has Jan read
- b. Zij heeft waarschijnlijk dat boek gekocht. [answer = (75b)]  
 she has probably that book bought
- b'. \*Zij heeft dat boek waarschijnlijk gekocht. [answer = (75b')]  
 she has that book probably bought

There are various analyses available for the word order variations in (75); see the reviews in the introduction in Corver & Van Riemsdijk (1994) and Broekhuis (2007/2008: Section 2.1). It has been claimed, for example, that the orders in (75) are simply base-generated, and that the word order variation should be accounted for by assuming either variable base-positions for the nominal arguments, as in Neeleman (1994a/1994b), or variable base-positions for the adverbial phrase, as in Vanden Wyngaerd (1989). Here we opt for a movement analysis, according to which the nominal argument is generated to the right of the clausal adverbial and optionally shifts into a more leftward position as indicated in (78).

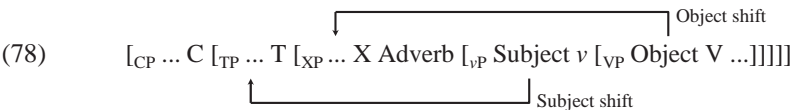

The optional subject shift in (78) is probably due to the same movement that we find in passive constructions such as (79b). As this movement places the subject in the position where nominative case is assigned, it has been suggested that the landing site of the optional object shift in (78) is a designated position in which accusative case is assigned; see Broekhuis (2008:ch.3) and the references cited there.

- (79) a. Gisteren heeft Jan<sub>Subject</sub> Marie<sub>IO</sub> de boeken<sub>DO</sub> aangeboden.  
 yesterday has Jan Marie the books prt.-offered  
 'Yesterday Jan offered Marie the books.'
- b. Gisteren werden <de boeken> Marie<sub>IO</sub> <de boeken> aangeboden.  
 yesterday were the books Marie prt.-offered  
 'Yesterday the books were offered to Marie (by Jan).'

The claim that subject and object shift target the nominative and accusative case positions implies that we are dealing with so-called °A-movement. This is supported by the fact discussed in Subsection IIIA that this movement is restricted to nominal arguments; Section 13.2 will argue that nominal argument shift has more hallmarks of A-movement.



### III. Negation-, focus-, and topic- movement

Subsection II has shown that nominal arguments can occupy different positions in relation to the adverbial phrases in the clause; this was illustrated by means of the placement of subjects and direct objects vis-à-vis clausal adverbs like *waarschijnlijk* 'probably'. We suggested that the word order variation is due to optional movement of the subject/object into a designated case position in the functional domain of the clause. If this suggestion is on the right track, we predict that this type of movement is restricted to nominal arguments: PP-complements of the verb, for example, are not assigned case and are therefore not associated either with a designated position in which case could be assigned. This raises the question as to how such PPs are able to occupy different positions in the middle field of the clause. Subsection A will show that the movement involved differs in non-trivial ways from nominal argument shift. The subsequent subsections will show that there are various other types of movements that affect the word order in the middle field of the clause: negation-, focus-, and topic movement. As their names suggest, these movements are clearly related to certain semantic properties of the moved elements.

#### A. Differences between nominal argument shift and movement of PP-complements

That PP-complements may occupy different surface positions in the clause is illustrated in the examples in (80), taken from Neeleman (1994a).

- (80) a. dat Jan nauwelijks op mijn opmerking reageerde.  
 that Jan hardly on my remark reacted  
 'that Jan hardly reacted to my remark.'
- b. dat Jan op mijn opmerking nauwelijks reageerde.  
 that Jan on my remark hardly reacted

That the difference in placement is the result of movement receives support from the fact illustrated in (81) that °R-extraction from the PP is only possible if the stranded preposition follows the clausal adverbial (in this case *nauwelijks* 'hardly'); if the (b)-examples in (80) and (81) are derived from the (a)-examples by leftward movement of the PP, this may be accounted for by appealing to the °freezing effect. Note that we added the time adverb *toen* 'then' in (81) in order to make the split of the pronominal PP *daarop* visible.

- (81) a. dat Jan *daar* toen nauwelijks op reageerde.  
 that Jan there then hardly on reacted  
 'that Jan hardly reacted to that then.'
- b. \*dat Jan *daar* toen op nauwelijks reageerde.  
 that Jan there then on hardly reacted

An important reason for assuming that the movement which derives the order in (80b) is different from nominal argument shift has to do with the distribution of PPs that contain a definite pronoun. Subsection II has already mentioned that definite subject/object pronouns normally undergo nominal argument shift: example (82a) is acceptable only if the pronoun *hem* is assigned contrastive accent: *Jan nodigt waarschijnlijk HEM uit (niet HAAR)* 'Jan will probably invite him (not her)'.



- (82) a. \*Jan nodigt waarschijnlijk hem/'m uit.  
 Jan invites probably him/him prt  
 b. Jan nodigt hem/'m waarschijnlijk uit.  
 Jan invites him/him probably prt.  
 'Jan will probably invite him.'

The examples in (83) show that this does not hold for PP-complements: if the nominal part of the PP is a definite pronoun, leftward movement is optional while it is excluded if the pronoun is phonetically reduced. It should be clear that the division between discourse-old and discourse-new information has no bearing on the leftward movement of PP-complements.

- (83) a. dat Jan nauwelijks naar hem/'m luisterde.  
 that Jan hardly to him/him listened  
 'that Jan hardly listened to him/him.'  
 a'. dat Jan naar hem/\*'m nauwelijks luisterde.  
 b. dat Jan nauwelijks naar haar/'r keek.  
 that Jan hardly at her/her looked  
 'that Jan hardly looked at her/her.'  
 b'. dat Jan naar haar/\*'r nauwelijks keek.

The unacceptability of the reduced pronouns in the primed examples is especially remarkable in light of the fact that nominal argument shift typically has the effect of destressing the moved element. Some speakers report that they accept examples such as (80b) only if the nominal complement of the PP is contrastively stressed: if true, this would suggest that we are dealing with focus movement, which will be the topic of Subsection C. That the moved PPs must be stressed is supported by the fact that the pronouns in the primed examples of (83) differ from the shifted pronoun in (82b) in that they cannot be phonetically reduced.

A second reason for assuming that the movement in (80b) is different from nominal argument shift is related to this effect: leftward movement of a complement PP under a neutral, that is, non-contrastive intonation pattern is only possible with a restricted set of adverbial phrases. If we replace the negative adverbial phrase *nauwelijks* 'hardly' in (80b) by the adverbial phrase *gisteren* 'yesterday', leftward movement of the PP gives rise to a degraded result (which can only be improved by giving the PP emphatic or contrastive stress). This is illustrated in (84) with three different PP-complements.

- (84) a. Jan heeft nauwelijks/gisteren op mijn opmerkingen gereageerd.  
 Jan has hardly/yesterday on my remarks reacted  
 a'. Jan heeft op mijn opmerkingen nauwelijks/\*gisteren gereageerd.  
 b. Jan heeft nauwelijks/gisteren naar Marie gekeken.  
 Jan has hardly/yesterday at Marie looked  
 b'. Jan heeft naar Marie nauwelijks/\*gisteren gekeken.  
 c. Jan heeft gisteren op vader gewacht.  
 Jan has yesterday for father waited  
 c'. \*Jan heeft op vader gisteren gewacht.

The primed examples in (84) with the adverb *gisteren* contrast sharply with similar examples with object shift, which can easily cross adverbs like *gisteren*: *Ik heb <dat boek> gisteren <dat boek> gelezen* 'I read that book yesterday'. For completeness' sake, note that some speakers report that the acceptability of the primed examples in (84) improves when *gisteren* is given emphatic accent.

Finally, the (a)-examples in (85) show that leftward movement of a PP-complement across an adverbial PP is always blocked, whereas object shift across such an adverbial PP is easily possible. For completeness' sake, note that the unacceptability of leftward movement in (85a) cannot be accounted for by assuming some constraint that prohibits movement of a complement of a certain categorial type across an adverbial phrase of the same categorial type, given that such a constraint would incorrectly exclude object shift across the adverbially used noun phrase *deze middag* 'this afternoon' in example (85b); cf. Verhagen (1986:78).

- (85) a. dat Jan <\*op Marie> na de vergadering <op Marie> wachtte.  
 that Jan for Marie after the meeting waited  
 'that Jan waited for Marie after the meeting.'
- a'. dat Jan <het boek> na de vergadering <het boek> wegbracht.  
 that Jan the book after the meeting away-brought  
 'that Jan delivered the book after the meeting.'
- b. dat Jan <dat boek> deze middag <dat boek> zal wegbrengen.  
 that Jan that book this afternoon will away-bring  
 'that Jan will deliver that book this afternoon.'

The discussion above has shown (contra Neeleman 1994a and Haeberli 2002) that leftward movement of PP-complements exhibits a behavior deviating from nominal argument shift, which in its turn suggests that it is a movement of some different type. The following subsections will show that there are indeed other types of leftward movement that may affect the word order in the middle field of the clause.

### B. Negation movement

Haegeman (1995) has argued for West-Flemish that negative phrases expressing sentential negation undergo obligatory leftward movement into the specifier of a functional head *Neg*; she further claims that this functional head can optionally be expressed morphologically by the negative clitic *en*: *da Valère niemand (en-)kent* 'that Valère does not know anyone'. Although Standard Dutch does not have this negative clitic, it is possible to show that it does have the postulated leftward movement of negative phrases; cf. Klooster (1994). At first sight, the claim that Standard Dutch has negation movement may be surprising, given that negative direct objects as well as PP-complements with a negative nominal part are normally left-adjacent to the verb(s) in clause-final position.

- (86) a. Jan heeft <\*niets> waarschijnlijk <niets> gezien.  
 Jan has nothing probably seen  
 'Jan has probably not seen anything.'
- b. Jan zal <\*op niemand> waarschijnlijk <op niemand> wachten.  
 Jan will for nobody probably waited  
 'Jan will probably not wait for anyone.'

That Standard Dutch has obligatory negation movement becomes evident, however, when we consider somewhat more complex examples. First, consider the examples in (87) with the adjectival complementive *tevreden* 'content/pleased', which takes a PP-complement headed by the preposition *over* 'about'. Although example (87a) shows that the PP-complement can either precede or follow the adjective, example (87b) strongly suggests that the A-PP order is the base order: leftward movement of the PP across the adjectival head gives rise to a freezing effect.

- (87) a. Jan is <over Peter> erg tevreden <over Peter>.  
 Jan is with Peter very content  
 'Jan is very content with Peter.'
- b. de jongen *waar* Jan <\*over> erg tevreden <over> is  
 the boy where Jan with very content is  
 'the boy whom Jan is very content with'

Example (88) shows that the PP-complement obligatorily moves to the left if its nominal part expresses sentence negation; examples with the order in (88a) are only acceptable with constituent negation: *Jan is tevreden met niets* 'Jan is content with anything' does not mean that Jan is not pleased with anything but, on the contrary, that he is even content with very little (cf. Haegeman 1995:130-1).

- (88) a. \*Jan is erg tevreden over niemand.  
 Jan is very content about no.one
- b. Jan is over niemand erg tevreden.  
 Jan is about no.one very content  
 'Jan is not quite content about anyone.'

The reason why negation movement is normally not visible in Standard Dutch is that the landing site of this movement is a relatively low position in the middle field of the clause and often applies °string-vacuously as a result. This will be clear from the fact illustrated in (89a) that the negative phrase from (88) preferably follows the clausal adverbial *waarschijnlijk* 'probably' under neutral intonation (the unacceptable order improves somewhat if the negative noun phrase is assigned contrastive accent). We have added example (89b) to show that it is not a coincidence that the PP-complement of the adjective is moved to this position following *waarschijnlijk*: the negative adverb *niet* 'not' appears to be base-generated in this position.

- (89) a. Jan is <\*over niemand> waarschijnlijk <over niemand> erg tevreden.  
 Jan is about no.one probably very content  
 'Jan is probably not quite content about anyone.'
- b. Jan is <\*niet> waarschijnlijk <niet> erg tevreden.  
 Jan is not probably very content  
 'Jan is probably not quite content.'

That we are dealing with an obligatory leftward movement is also supported by the examples in (90); example (90a) shows again that PP-complements can normally either precede or follow the clause-final verb; if the nominal part of the PP-complement expresses sentence negation, however, the PP-complement must

precede the verb, which would follow immediately if it undergoes obligatory leftward movement.

- (90) a. Jan wil <op zijn vader> wachten <op zijn vader>.  
 Jan wants for his father wait  
 ‘Jan wants to wait for his father.’  
 b. Jan wil <op niemand> wachten <\*op niemand>.  
 Jan wants for nobody wait  
 ‘Jan does not want to wait for anyone.’

This subsection has shown that phrases expressing sentence negation obligatorily move into some designated position to the right of the modal adverb *waarschijnlijk* ‘probably’. This shows that there are movement operations affecting the order of the constituents in the middle field of the clause that are different from nominal argument shift, given that the latter movement typically crosses the modal adverb.

### C. Focus movement

The notion of focus used here pertains to certain elements in the clause that are phonetically highlighted by means of accent, that is, EMPHATIC and CONTRASTIVE focus. Emphatic focus highlights one of the constituents in the clause, as in (91a). Contrastive focus is normally used to express that a certain predicate exclusively applies to a certain entity or to deny a certain presupposition on the part of the hearer, as in (91b).

- (91) a. Ik heb hem een BOEK gegeven.  
 I have him a book given  
 ‘I have given him a BOOK.’  
 b. Nee, ik heb hem een BOEK gegeven (en geen PLAAT).  
 no, I have him a book given and not a record  
 ‘No, I gave him a BOOK (and not a RECORD).’

Although example (92a) strongly suggests that focused phrases may remain in their base-position, example (92b) shows that they can also occur in clause-initial position.

- (92) a. dat Jan erg trots op zijn BOEK is (maar niet op zijn ARTIKEL).  
 that Jan very proud of his book is but not of his article  
 ‘that Jan is very proud of his BOOK (but not of his ARTICLE)’  
 b. Op zijn BOEK is Jan erg trots (maar niet op zijn ARTIKEL).  
 of his book is Jan very proud but not of his article

That focus phrases may occur in clause-initial position is not surprising given that cross-linguistically they behave very much like *wh*-phrases. In the Gbe languages (Kwa, for example), both types of phrases must occupy the clause-initial position and are obligatorily marked with the focus particle *wè*, as shown in the examples in (93) taken from Aboh (2004:ch.7). The same is shown by Hungarian, where interrogative and focused phrases are placed in the same position left-adjacent to the finite verb; see É. Kiss (2002:ch.4) for examples.

- (93) a. wémà wè Sénà xiá.  
 book FOCUS Sena read<sub>perfective</sub>  
 ‘Sena read A BOOK.’
- b. éte wè Sénà xiá?  
 what FOCUS Sena read<sub>perfective</sub>  
 ‘What did Sena read?’

Given that focus phrases occupy a fixed position in languages like Kwa and Hungarian, it may be somewhat puzzling that in Standard Dutch focus phrases may occupy various positions in the middle field of the clause. The examples in (94) illustrate this by means of the PP-complement of the adjective *trots* ‘proud’ in (92).

- (94) a. dat Jan waarschijnlijk op zijn BOEK erg trots is (maar niet op zijn ARTIKEL).  
 that Jan probably of his book very proud is but not on his article  
 ‘that Jan is probably very proud of his BOOK (but not of his ARTICLE).’
- b. dat Jan op zijn BOEK waarschijnlijk erg trots is (maar niet op zijn ARTIKEL).  
 that Jan of his book probably very proud is but not on his article  
 ‘that Jan is probably very proud of his BOOK (but not of his ARTICLE).’

That focused phrases may occupy a variety of surface positions in the clause has challenged the standard assumption that there is a unique position for such phrases to move into and has led to proposals adopting a more flexible approach; cf., e.g., Neeleman & Van de Koot 2008. We will not take a stand on this issue here, but simply conclude that the examples in this subsection show that focused phrases can optionally undergo leftward movement.

#### *D. Topic movement*

The term topic is taken quite broadly here as aboutness-topic; it refers to the entity that the sentence is about. Typical examples are given in (95), which show that aboutness-topics are typically accented and may precede the subject if it is focused (which we have forced in (95) by combining the subject with the focus particle *alleen* ‘only’).

- (95) a. dat DIT BOEK alleen Jan gelezen heeft.  
 that this book only Jan read has  
 ‘that this book only Jan has read.’
- b. dat ZULKE BOEKEN alleen Jan wil lezen.  
 that such books only Jan wants read  
 ‘that such books only Jan wants to read.’

The fact that leftward movement of aboutness-topics may change the underlying order of the arguments in the middle field (a property that according to some also holds for focus movement) shows that we are once more dealing with a movement type that differs from nominal argument shift discussed in Subsection II. That this is the case is also clear from the fact illustrated in (96) that aboutness-topics need not be nominal in nature, but can also be PPs or (complementive) APs.

- (96) a. dat OP DIE BESLISSING alleen Jan wil wachten.  
 that for that decision only Jan wants wait  
 ‘that only Jan wants to wait for that decision.’
- b. dat ZO STOM alleen Jan kan zijn.  
 that that stupid only Jan can be  
 ‘that only Jan can be that stupid.’

#### IV. Conclusion

This section has shown that in Standard Dutch the word order in the middle field of the clause is relatively free. Although in older versions of generative grammar this was accounted for by assuming a generic stylistic scrambling rule, the discussion has shown that the attested word order variation is derived by means of a wider set of movement types. The first type is referred to as nominal argument shift: nominal arguments can move out of the lexical domain of the clause into a number of designated positions in the middle field where they are assigned case, provided that they express discourse-old information. There are a number of additional conditions on this type of movement that were ignored here, but the reader can find a discussion of these in Section 13.2. Besides nominal argument shift, there are a number of movement types typically targeting constituents with a specific semantic property: constituents which express sentence negation, which are contrastively focused, or which function as the aboutness-topic of the clause. We have seen that these movements all have their own peculiarities in terms of their landing site: negative phrases obligatorily target a position to the right of modal clausal adverbs like *waarschijnlijk* ‘probably’; focus movement is optional and is relatively free when it comes to the choice of its landing site; and aboutness-topics are special in that they can readily precede the subject of the clause if the latter is contrastively focused.

#### 9.6. Conclusion

This chapter has given a bird’s eye view of the organization of the clause in Standard Dutch. We have seen that the clause can be divided into three parts on the basis of the position of the complementizer/verbs. The first part is the clause-initial position preceding the complementizer/finite verb in second position, which is the landing site for interrogative and topicalized phrases. The second is the postverbal field following the verbs in clause-final position, in which we find a wide variety of constituents with the exception of nominal arguments, complementives and manner adverbs. The remaining part of the clause is the middle field in between the complementizer/finite verb in second position and the verb(s) in clause-final position. We have seen that the word order in this part of the clause is relatively free and is determined by a variety of movement rules, which are often (incorrectly) lumped together as scrambling. In Chapter 10 to Chapter 13 we will discuss the movements operations that were introduced in this chapter in more detail.



## **Chapter 10 Word order in the clause II: Position of the finite verb (verb-first/second)**

<b>Introduction</b>	<b>1244</b>
<b>10.1. Placement of the finite verb</b>	<b>1245</b>
<b>10.2. Verbal (X+V) collocations and verb-first/second</b>	<b>1253</b>
<b>10.3. Verb-first/second: special cases</b>	<b>1290</b>
<i>10.3.1. No Verb-first/second in main clauses?</i>	<i>1291</i>
<i>10.3.2. Verb-first/second in embedded clauses?</i>	<i>1296</i>



**Introduction**

This chapter takes as its point of departure the discussion in 9.2, which has shown that finite verbs can be found in basically two positions: the clause-final position in embedded clauses and the verb-first/second position in main clauses; the latter position is normally occupied by a complementizer in embedded clauses.

- (1) a. Marie zegt [dat Jan het boek *leest*].  
 Marie says that Jan the book reads  
 ‘Marie says that Jan is reading the book at this moment.’
- b. Op dit moment *leest* Jan het boek.  
 at this moment reads Jan the book  
 ‘At this moment, Jan is reading the book.’

On the basis of these two positions, the clause can be divided into various “topological” fields: the clause-initial position, the middle field and the postverbal field. This is illustrated in Figure (2), repeated from Section 9.2. This chapter will focus on the placement of the verbs; the core observation is that complementizers and finite verbs compete for the C-position; because embedded clauses are obligatorily introduced by a complementizer normally, verb second is restricted to main clauses.

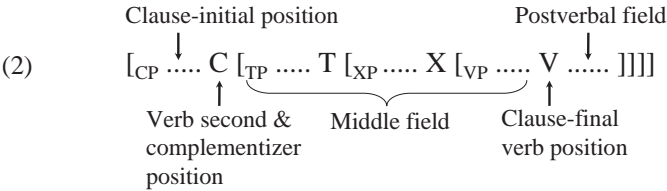

Section 10.1 starts by introducing the rule of verb-first/second which places finite verbs in the C-position in main clauses. Section 10.2 continues with a complicating issue, namely that verbal collocations may exhibit different behavior under verb-second: there are verbal, compound-like collocations that undergo verb-second as a whole, collocations that are split under verb-second, and collocations that resist verb-second altogether. In (3), we illustrate this for N+V collocations, but copious similar examples can be found with, e.g., particle verbs. We will discuss a number of properties that distinguish the three types of collocation.

- (3) a. dat Jan haar als verrader *brandmerkt*. [inseparable]  
 that Jan her as traitor brands  
 ‘that Jan stigmatizes her as a traitor.’
- a'. Jan *brandmerkt* haar als verrader.  
 Jan brands her as a traitor
- b. dat Jan elke dag *paardrijdt*. [separable]  
 that Jan every day rides.horseback  
 ‘that Jan goes for a ride every day.’
- b'. Jan *rijdt* elke dag *paard*.  
 Jan rides every day horseback

- c. dat Marie in het weekend *stijldanst*. [immobile]  
 that Marie in the weekend ballroom.dances  
 ‘that Marie ballroom dances during the weekend.’
- c’. Marie <<sup>%</sup>*stijl*>*danst* in het weekend <\**stijl*>.  
 Marie ballroom.dances in the weekend

Section 10.3 concludes with a discussion of verb-first/second in a limited set of supposedly embedded adverbial clauses. Prototypical cases are conditional adverbial clauses such as (4b), which alternates with the regular embedded clause introduced by the complementizer-like element *als* ‘if’ in (4a).

- (4) a. Als hij te laat *komt*, dan help ik hem niet meer.  
 if he too late comes then help I him not anymore  
 ‘If he gets in too late, I won’t help him anymore.’
- b. *Komt* hij te laat, dan help ik hem niet meer.  
 comes he too late then help I him not anymore  
 ‘If he arrives too late, then I won’t help him anymore.’

### 10.1. Placement of the finite verb

Example (5a) shows that in embedded clauses verbs are situated in what is normally referred to as the clause-final position. Since the use of this notion may give rise to various misunderstandings, Subsection I starts by briefly discussing some potential problems with this notion. After this, Subsection II continues with a discussion of verb-first/second (often simply referred to as verb-second), that is, the movement operation that places the finite verb in the first or second position of main clauses. Verb-second is generally found in declarative clauses, in which the finite verb is preceded by the subject or some other phrase; *wh*-questions such as (5b) are prototypical instantiations of the latter case. Verb-first is found if the first position of the sentence remains (phonetically) empty; *yes/no*-questions such as (5c) are prototypical instantiations of this.

- (5) a. dat Jan dat boek *wil*<sub>finite</sub> *lezen*<sub>infinitive</sub>. [verb-final]  
 that Jan that book wants read  
 ‘that Jan wants to read that book.’
- b. Wat *wil*<sub>finite</sub> Jan *lezen*<sub>infinitive</sub>? [verb-second]  
 what wants Jan read  
 ‘What does Jan want to read?’
- c. *Wil*<sub>finite</sub> Jan dat boek *lezen*<sub>infinitive</sub>? [verb-first]  
 wants Jan that book read  
 ‘Does Jan want to read that book?’

Subsection III concludes the discussion of the placement of the finite verb by considering the verb-first/second rule from a cross-linguistic perspective.

#### I. Clause-final verbs

Verbs are normally in clause-final position; Subsection II will show that the only exception is the finite verb, which is moved into first/second position in main clauses. The use of the notion CLAUSE-FINAL POSITION is inadequate in various

respects. First, it suggests that the clause-final verbs demarcate the right boundary of the clause, whereas examples like (6a&b) show that they may in fact be followed by various other constituents, such as PP-complements and embedded clauses; see Chapter 12 for more discussion. The notion “clause-final” should therefore be defined more loosely as “in the right periphery of the clause”.

- (6) a. dat Jan al de hele dag wacht op antwoord.  
 that Jan already the whole day waits for answer  
 ‘that Jan has been waiting for an answer all day.’  
 b. dat Jan aan Peter vertelt dat hij naar Groningen gaat.  
 that Jan to Peter tells that he to Groningen goes  
 ‘that Jan tells Peter that he’ll go to Groningen.’

Second, the use of the notion CLAUSE-FINAL POSITION may suggest that the clause-final verbs are base-generated as part of a °verbal complex in a specific position of the clause. An example of such a verbal complex is given in (7), in which the finite verb *moet* ‘must’ is in clause-final position in the embedded clause in (7a), but moved into the second position in the main clause in (7b).

- (7) a. dat hij dat boek morgen moet hebben gelezen.  
 that he that book tomorrow must have read  
 ‘that he must have read that book by tomorrow.’  
 b. Hij moet dat boek morgen  $t_{moet}$  hebben gelezen.  
 he must that book tomorrow have read  
 ‘He must have read that book by tomorrow.’

Postulating a base-generated verbal complex is, however, not what is generally assumed in generative grammar: there are reasons for assuming that the verbs which enter the verbal complex are all base-generated as heads of independent verbal projections in a hierarchical structure. This structure is insightfully shown in the English translation of (7a) in (8). The structural representation in (8) formally expresses the intuition that the perfect auxiliary *have* selects a phrase headed by a participle and that the modal verb *must* selects a phrase headed by an infinitive; see Section 5.2 and Chapter 6 for extensive discussion.

- (8) that he must [have [read that book tomorrow]].

The fact that the verbs in the Dutch examples in (7) tend to cluster in clause-final position must therefore be epiphenomenal (which is clearly the case for the adjacent sequence of the verbs in English examples such as (8), which can easily be interrupted by adverbs) or the result of some movement operation. The latter is the option traditionally chosen for Germanic OV-languages like Dutch and German, and this has motivated the postulation of verb-clustering operations like Evers’ (1975) verb raising. We confine ourselves here to noting this issue, and refer the reader to Chapter 7 for an extensive discussion of °verb clustering.

It should also be emphasized that the term clause-final position is a technical term which refers to a more deeply embedded position in the phrase structure, that is, a position at least internal to XP in Figure (2). Despite the fact that the finite verbs are “clause-final” in a pre-theoretical sense in the two primeless examples in

(9), we will maintain that the finite verb is in clause-final position in the technical sense in (9a) only; in (9b) the finite verb is in second position (T or C). The difference between the two positions will become evident immediately if we add additional constituents, like the adverbial phrases *graag* ‘gladly’ and *in het park* ‘in the park’ in the primed examples.

- |     |    |                           |     |   |
|-----|----|---------------------------|-----|---|
| (9) | a. | dat Jan <i>wandelde</i> . | a'. | dat Jan graag in het park <i>wandelde</i> . |
|     |    | that Jan walked           |     | that Jan gladly in the park walked          |
|     |    | ‘that Jan was walking.’   |     | ‘that Jan liked to walk in the park.’       |
|     | b. | Jan <i>wandelde</i> .     | b'. | Jan <i>wandelde</i> graag in het park.      |
|     |    | Jan walked                |     | Jan walked gladly in the park               |
|     |    | ‘Jan was walking.’        |     | ‘Jan liked to walk in the park.’            |

For the primed examples in (9), we will maintain that the adverbial phrases occupy not only the middle field in (9a') but also in (9b'). This is, however, difficult to demonstrate in the latter case as the clause-final verb position is empty. In some cases, however, the presence of the clause-final position can be established indirectly with the help of some other element in the clause. This can be illustrated in a simple way by means of separable particle verbs like *doorgeven* ‘to pass on’ in (10). The primeless examples clearly show that nominal and clausal direct objects differ in that the former occupy a position in the middle field, whereas the latter occupy a position in the postverbal field of the clause. But the same can be indirectly established from the position of the particle *door* in the corresponding main clauses in the primed examples, given that particles are normally placed left-adjacent to the verb in clause-final position.

- |      |     |   |
|------|-----|---|
| (10) | a.  | dat Jan <het zout> doorgaf <*het zout>.                     |
|      |     | that Jan the salt prt.-gave                                 |
|      |     | ‘that Jan passed the salt.’                                 |
|      | a'. | Jan gaf <het zout> door <*het zout>                         |
|      |     | Jan gave the salt prt.                                      |
|      |     | ‘Jan passed the salt.’                                      |
|      | b.  | dat Jan <*dat Peter ziek was> doorgaf <dat Peter ziek was>. |
|      |     | that Jan that Peter ill was prt.-gave                       |
|      |     | ‘that Jan passed the message on that Peter was ill.’        |
|      | b'. | Jan gaf <*dat Peter ziek was> door <dat Peter ziek was>.    |
|      |     | Jan gave that Peter ill was prt.                            |
|      |     | ‘Jan passed the message on that Peter was ill.’             |

There is a whole series of elements that are normally left-adjacent to the verb(s) in clause-final position, including °complementives and °stranded prepositions; we refer the reader to Chapter 13 for discussion and examples.

## II. Verb-first/second

In main clauses, finite verbs are normally situated in the first or second position. We will adopt the generally accepted assumption from generative grammar that all verbs are base-generated in some lower position in the clause—they all head some projection of their own—and that finite verbs are special in that they can be moved

into the verb-first/second (C or T) position in main clauses. The special status of finite verbs is normally accounted for by assuming that the verb-first/second position contains temporal (T) and/or illocutionary force features (C) associated with the finite verb.

The contrast between embedded and main clauses with respect to the position of finite verbs is illustrated again in (11); note that *gisteren* ‘yesterday’ is in first position in (11a’) as a result of topicalization; in *yes/no*-questions such as (11b’), this position remains (phonetically) empty and the verb ends up in first position as a result. For this reason verb-first and verb-second are often considered special instantiations of a single rule, and verb-second is normally used as a cover term for the two cases, a practice that we will follow here.

- (11) a. Marie zegt [dat Jan gisteren dat boek heeft gekocht]. [declarative]  
 Marie says that Jan yesterday that book has bought  
 ‘Marie says that Jan bought that book yesterday.’  
 a’. Gisteren heeft Jan dat boek gekocht.  
 yesterday has Jan that book bought  
 ‘Jan bought that book yesterday.’  
 b. Marie vraagt [of Jan gisteren dat boek heeft gekocht]. [interrogative]  
 Marie asks if Jan yesterday that book has bought  
 ‘Marie asks whether Jan bought that book yesterday.’  
 b’. Heeft Jan gisteren dat boek gekocht?  
 has Jan yesterday that book bought  
 ‘Did Jan buy that book yesterday?’

The restriction of verb-second to main clauses suggests that complementizer insertion and verb-second are in complementary distribution. Under the traditional analysis, based on Paardekooper (1961) and Den Besten (1983), this follows from the claim that complementizers and finite verbs both target the C-position, as indicated in (12a). For completeness’ sake, we show in (12b) that a verb-second construction such as (11b’) is derived by means of an additional movement of some phrase into the specifier of CP, that is, the position immediately preceding the C-position. In *yes/no*-questions such as (11b’) the finite verbs ends up in first position because no phonetically realized material can be moved to the sentence-initial position (perhaps due to the presence of some empty question operator in the specifier of CP).

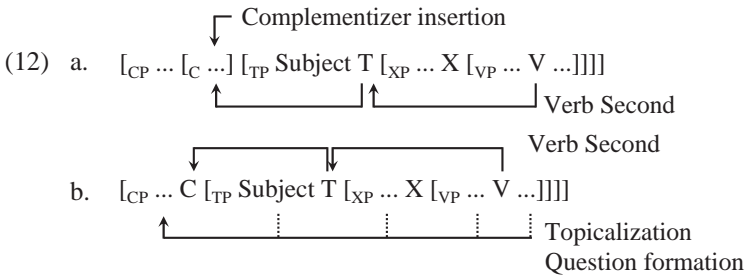

The traditional analysis of verb-second in (12) maintains that in main clauses the finite verb always targets the C-position; consequently, any phrase preceding the verb in second position must have been placed there by means of topicalization (or *wh*-movement). Section 9.3 has shown, however, that subject-initial sentences differ from other verb-second sentences in that the finite verb can be preceded by an unstressed element: example (13a) is acceptable regardless of whether the subject pronoun is stressed or not, while the (b)- and (c)-examples in (13) show that other clause-initial (topicalized) phrases must be stressed.

- (13) a. *Zij/Ze* moet mij helpen. [subject pronoun in initial position]  
 she/she must me help  
 ‘She must help me.’
- b. *Haar/\*’r* moet ik helpen. [object pronoun in initial position]  
 her/her must I help  
 ‘I must help her.’
- c. *Op haar/\*’r* wil ik niet wachten. [prepositional object in initial position]  
 for her/her want I not wait  
 ‘I don’t want to wait for her.’
- c’. *Daarop/\*Erop* wil ik niet wachten. [pronominal PP in initial position]  
 for that/for it want I not wait  
 ‘I don’t want to wait for that.’

The (b)- and (c)-examples in (13) thus strongly suggest that phonetically reduced subject pronouns like *ze* ‘she’ in (13a) cannot occupy the specifier position of CP, which in turn suggests that they are located in the regular subject position, that is, the specifier of TP. Given that there is no *a priori* reason for assuming that non-reduced subject pronouns like *zij* ‘she’ and non-pronominal subjects must be treated differently, the null hypothesis seems to be that what we posit for phonetically reduced subject pronouns holds for all subjects. So we arrive at the hypothesis that subject-initial sentences normally have the structure in (14); See Travis (1984) and Zwart (1992/1997).

- (14) • Subject-initial sentences
- $\downarrow$  Verb Second  
 [<sub>TP</sub> Subject T [<sub>XP</sub> ... X [<sub>VP</sub> ... V ...]]]

The Travis/Zwart-hypothesis, which assigns different structures to subject-initial sentences (TPs) and other verb-second constructions (CPs), may also explain another fact. The subject pronoun *je* ‘you’ triggers different types of agreement depending on its position relative to the finite verb, as shown in (15). Let us assume that the morphological realization of subject-verb agreement depends on the location of the finite verb in the clause, T or C; see Zwart (1997) and Postma (2011). In (15a) the finite verb occupies the T-position and second person singular agreement is morphologically expressed by *-t*, whereas in (15b) it occupies the C-position and second person singular agreement is expressed by  $-\emptyset$ .

- (15) a. [<sub>TP</sub> Je krijgt [<sub>XP</sub> morgen een cadeautje *t<sub>V</sub>*]].  
           you get<sub>2p.sg</sub> tomorrow a present  
           ‘You’ll get a present tomorrow.’
- b. [<sub>CP</sub> Morgen krijg-Ø [<sub>TP</sub> je *t<sub>V</sub>* [<sub>XP</sub> *t<sub>morgen</sub>* een cadeautje *t<sub>V</sub>*]]].  
           tomorrow get<sub>2p.sg</sub> you a present  
           ‘You’ll get a present tomorrow.’

If we accept the proposals in (12b) and (14), the term verb-second no longer uniquely refers to verb movement into the C-position, and in the more recent formal-linguistic literature it is therefore often replaced by the more precise notions V-to-T and V-to-C. We will, however, stick to the term verb-second as a convenient descriptive term.

Since the Travis/Zwart-hypothesis is highly theory-internal, we will not discuss it in any further detail, but we do want to point out that it has given rise to various hotly debated issues. First, the Travis/Zwart-hypothesis presupposes that the T-position in Dutch is located to the left of the lexical projections of the verb(s), as depicted in (14), and thus diverges from the more traditional claim, motivated by the OV-nature of Dutch, that the T-position is located to the right of these projections; the base structure [<sub>CP</sub> .. C [<sub>TP</sub> .. [<sub>VP</sub> .. V ..] T]] is not compatible with this hypothesis. Secondly, the Travis/Zwart-hypothesis is incompatible with the traditional claim that the complementary distribution of complementizer insertion and verb-second follows from the fact that the complementizer and the finite verb both target the C-position, given that the finite verb could in principle also be moved into the T-position; this is illustrated in (16b).

- (16) a. [C dat] Jan [<sub>T</sub> — ] dat boek gisteren heeft gekocht.  
           that Jan that book yesterday has bought  
           ‘that Jan bought that book yesterday.’
- b. \*[C dat] Jan [<sub>T</sub> heeft ] dat boek gisteren *t<sub>heeft</sub>* gekocht.

Thirdly, the Travis/Zwart-hypothesis makes it impossible to account for the obligatory nature of verb-second in main clauses by simply stating that the C-position must be lexically filled; instead, we have to assume that the *highest* head position in the extended projection of the verb be lexically filled: T in subject-initial main clauses and C in other verb-second constructions as well as embedded clauses. Finally, the Travis/Zwart-hypothesis raises the question as to *why* the T-position cannot be filled in Dutch embedded clauses, that is, why examples such as (16b) are unacceptable. A functional explanation for this might be that a complementizer or a finite verb in first/second position is used in Dutch to signal the beginning of a new clause; see Zwart (2001) and Broekhuis (2008) for a formalization of this intuition; see Zwart (2011) for a more detailed review of theoretical approaches to verb-second.

### *III. A comparative perspective on the placement of the finite verb*

The rules determining the placement of finite verbs in Dutch are relatively simple: finite verbs occur in the verb-second position in main clauses but occupy the so-called clause-final position in embedded clauses (where they cluster with the non-finite verbs). The examples in (17) illustrate this once again.



- (17) a. Jan *leest* dit boek niet. a'. dat Jan dit boek niet *leest*.  
 Jan reads this book not that Jan this book not reads  
 'Jan doesn't read this book.' 'that Jan doesn't read this book.'
- b. Jan *heeft* dit boek niet gelezen. b'. dat Jan dit boek niet gelezen *heeft*.  
 Jan has this book not read that Jan this book not read has  
 'Jan hasn't read this book.' 'that Jan hasn't read this book.'

This can be described by claiming that the finite verb is base-generated in the clause-final V-position in the universally valid template in (18), repeated from Section 9.1, but is moved into second position by verb-second in main clauses. Subsection II further suggested that the categorial status of the verb-second position depends on the sentence-initial phrase: it can be identified as T in subject-initial sentences and as C in all other cases.

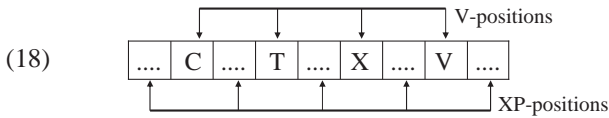

The universal template in (18) can be taken to imply that the situation might very well have been different, in the sense that the Dutch rules are simply a more or less random selection from a wider range of verb movement possibilities. This is in fact confirmed by cross-linguistic evidence. Consider the Icelandic examples in (19), taken from Jónsson (1996:9-10). When we compare the primeless and primed examples, we see that, at least at face value, the finite verbs seem to occupy the same position in main and embedded clauses, and since the finite verb is adjacent to the subject we may assume that the position in question is T. The fact that the main verbs in the (a)- and (b)-examples occupy different positions with respect to the adverb *ekki* 'not' shows that non-finite verbs occupy a position lower in the structure than finite verbs (X or V depending on what the position of the direct object is taken to be). This suggests that finite verbs are moved from the V-position into the T-position in Icelandic (or the C-position in constructions with verb-subject inversion).

- (19) a. Jón las ekki þessa bók. a'. að Jón las ekki þessa bók.  
 Jón read not this book that Jón read not this book  
 'Jón didn't read this book.' 'that Jón didn't read this book.'
- b. Jón hefur ekki lesið þessa bók. b'. að Jón hefur ekki lesið þessa bók.  
 Jón has not read this book that Jón has not read this book  
 'Jón hasn't read this book.' 'that Jón hasn't read this book.'

The difference between Dutch and Icelandic shows that these languages differ with respect to the question as to whether there is an asymmetry in verb movement between root and embedded clauses; the examples in (18) and (19) show that this is the case in Dutch, which is therefore classified as an asymmetric verb movement language, but not in Icelandic, which is therefore classed as a symmetric verb movement language. The examples in (20) show that English is also a symmetric verb movement language but exhibits an asymmetry between main and non-main verbs. The symmetric verb movement behavior in root and embedded clauses will



be clear from the comparison between the primeless and primed examples. The asymmetry between main and non-main verbs is clear from the contrast between the (a)- and (b)-examples, which shows that while non-main verbs must precede the frequency adverb *often*, main verbs must follow it.

- (20) a. John often read this book.  
       a'. that John often read this book.  
       b. Jan has often read the book.  
       b'. that John has often read this book.

There are also symmetric verb movement languages that do not have verb-second at all: Japanese, for example, consistently has the finite verb in clause-final position, as is illustrated in the examples in (21), cited from Tallerman (2015).

- (21) a. Hanakoga susi-o tukurimasita.  
       Hanako-NOM sushi-ACC made  
       ‘Hanako made sushi.’  
       b. Taroo-ga [Hanako-ga oisii susi-o tukutta to] itta.  
       Taroo-NOM Hanako-nom delicious sushi-ACC made COMP said  
       ‘Taro said that Hanako made delicious sushi.’

From a cross-linguistic perspective on verb movement, Dutch has at least the following distinctive properties: (i) it has V-to-T/C, (ii) V-to-T/C holds for main and non-main verbs, and (iii) V-to-T/C applies in root clauses only. The chart in (22) summarizes the differences with the other languages mentioned.

(22) Finite verb movement

	V-TO-T/C	MAIN/NON-MAIN VERB	ROOT/NON-ROOT CLAUSE
ICELANDIC	+	symmetric	symmetric
DUTCH	+	symmetric	asymmetric
ENGLISH	+	asymmetric	symmetric
JAPANESE	—	symmetric	symmetric

The properties in Table (22) correctly place Dutch in the same class as German. It should be noted, however, that Dutch and German differ in one important respect: whereas German sometimes allows verb-second in embedded clauses without complementizers, Dutch does not; see Haider (2010:46-8). The examples in (23) first show that German has two forms of embedded declarative clauses: one with the complementizer *dass* ‘that’ and a clause-final finite verb, and one without a complementizer and a verb in second position. Embedded verb-second especially occurs in cases in which the finite verb is a subjunctive; note that the adverbial phrase *nie zuvor* ‘never before’ is placed in clause-initial position in (23b) and that the verb precedes the subject, so that we may conclude that the finite verb occupies the C-position.

- (23) a. Peter sagte [dass er nie zuvor so einen guten Artikel gelesen hätte].  
 Peter said that he never before such a good article read had  
 ‘Peter said that he’d never read such a good article before.’  
 b. Peter sagte [nie zuvor hätte er so einen guten Artikel gelesen].  
 Peter said never before had he such a good article read

The Dutch counterparts of (23) in (24) show that Dutch does not allow verb-second in embedded clauses. The number sign in (24b) indicates that this example is acceptable if the bracketed clause within straight brackets is construed as a direct quote, but this is not the intended reading here. For completeness’ sake, it should be noted that embedded verb-second constructions are possible in some non-standard varieties of Dutch; see Barbiers et al (2005: Section 1.3.1.8).

- (24) a. Peter zei [dat hij nooit eerder zo’n goed artikel gelezen had].  
 Peter said that he never before such a good article read had  
 ‘Peter said that he’d never read such a good article before.’  
 b. #Peter zei [nooit eerder had hij zo’n goed artikel gelezen].  
 Peter said never before had he such a good article read

This section has shown that certain placements of finite verbs that are theoretically possible and in fact occur in other languages are excluded in Dutch. The universally valid template in (18) can be used to provide a descriptively adequate account of the variation in verb placement in the languages discussed in this section by setting the parameters in Table (22). The actual setting is, of course, a language-specific matter.

## 10.2. Verbal (X+V) collocations and verb-first/second

Verb-first/second is normally obligatory in main clauses, but there are cases in which it seems only marginally possible. A typical example is (25), with the N+V collocation *touwtje springen* ‘to (rope) skip’.

- (25) a. dat Peter op straat touwtje springt.  
 that Peter in the.street rope skips  
 ‘that Peter is skipping in the street.’  
 b. ?Peter springt op straat touwtje.  
 c. \*Peter touwtje springt op straat.

Collocations like *touwtje springen* denote conventionalized activities and have word-like status, as is clear from the fact illustrated in (26) that this collocation can be placed as a whole in the verbal position of a progressive *aan het* +  $V_{\text{infinitive}}$  phrase. However, the fact that the nominal part *touwtje* can also be separated from the verbal part *springen* suggests that we cannot analyze this collocation as a regular compound. For this reason, we will diverge from the orthographic convention to write such N+V collocations as a single word in order not to bias the discussion below towards a compound analysis for such collocations.

- (26) dat Peter <touwtje> aan het <touwtje> springen is.  
 that Peter rope AAN HET skip is  
 ‘that Peter is skipping.’

Examples such as (25) can be approached in several ways. One possibility is to deny that collocations like *touwtje springen* have finite forms, as is claimed for a large set of such N+V collocations at taaladvies.net/taal/advies/vraag/703, probably on the basis of information provided by the Van Dale Dictionary. For many of these verbs, this cannot be maintained given that their finite forms are easy to find on the internet. A Google search (11/11/2013) on [*touwtje springt*] resulted in more than 300 hits, and a cursory inspection of these results showed that most of them indeed involve embedded clauses such as (25a). Actually, it is not difficult either to find past-tense examples: our Google searches on the strings [*touwtje sprong*] and [*touwtje sprongen*] resulted in more than 200 hits, two of which are given in (27).

- (27) a. de buurmeisjes      waarmee    ik    touwtje sprong of hinkelde  
 the girls.next.door with.whom I    rope    skipped or played.hopscotch  
 ‘the girls next door with whom I skipped or played hopscotch’
- b. Er    waren [...] een paar meisjes    die    touwtje sprongen.  
 there were          a couple [of] girls who rope    skipped  
 ‘There were a couple of girls who were skipping.’

A second possibility is to deny that the contrast between examples like (25a&b) is real and to assume that both types of examples are equally acceptable. This position can be supported by the fact that verb-second examples such as (25b) can indeed be found on the internet. The number of such examples is relatively small, however: our Google searches on [*springt touwtje*] and [*springt \* touwtje*] resulted in, respectively, 136 and 56 hits, many of which were irrelevant or duplicates. Verb-second constructions with *touwtje springen* are especially popular in headlines, headers, captions of pictures and movies, etc. In regular texts, verb-second seems relatively frequent in sentences with a habitual reading and in sentences in which the collocation is used as part of a list (often in brief summaries of certain events); two typical examples are given in (28).

- (28) a. Sylvia Goegebuur (sic) [...] springt touwtje als de beste ter wereld.  
 Sylvia Goegebuur                    skips rope    like the best in.the world
- b. Hij kruipt over de piano, trekt zijn hemd uit en springt touwtje  
 he crawls over the piano takes his shirt off and jumps rope  
 met de microfoon.  
 with the microphone  
 ‘He crawls all over the piano, takes off his shirt and skips with the mike.’

The past tense strings [*sprong touwtje*] and [*sprong \* touwtje*] resulted in 95 hits in total, many of which were again irrelevant or duplicates: our estimate is that there were about 20 genuine cases of verb-second. Sentences in which the collocation is used as part of a list, as in *Hij liep, hij rende en sprong touwtje* ‘he walked, (he) ran and skipped’, again seem to be relatively frequent.

The results of our Google searches suggest a third possibility: for most speakers, verb-second of the finite form of the verbal part of N+V collocations like *touwtje springen* is disfavored, and since non-finite forms do not occur in second position, this verb is normally used in clause-final position only. Since these collocations express conventionalized activities, verb-second can easily be avoided

in many cases by employing the progressive *aan het* +  $V_{\text{infinitive}}$  construction in (29a) instead of the verb-second construction in (29b).

- (29) a. Peter is/was <touwtje> aan het <touwtje> springen.  
 Peter is/was rope AAN HET skip  
 ‘Peter is/was skipping.’  
 b. <sup>??</sup>Peter springt/sprong touwtje.  
 Peter skips/skipped rope

A similar conclusion was drawn by Booij (2010:114) for the N+V collocation *stijl dansen*, despite the fact that some speakers seem to be able to treat this collocation as a true (inseparable) compound: examples such as (30b) can again normally be avoided by using the progressive construction *Hij is/was met zijn nichtje aan het stijldansen* ‘He is/was ballroom dancing with his niece’.

- (30) a. dat hij met zijn nichtje stijl danst/danste.  
 that he with his niece ballroom dances/danced  
 ‘that he is/was ballroom dancing with his niece.’  
 b. <sup>??</sup>Hij stijldanst/stijldanste met zijn nichtje.  
 c. \*Hij danst/danste met zijn nichtje stijl.

Certain particle verbs have also been reported to disfavor verb-second. Such particle verbs are characterized by the fact that their particles are complex, like *voor-aan* in *vooraanmelden* ‘to preregister’, or preceded by the prefix *her-*, as in *herinvoeren* ‘to reintroduce’; see Koopman (1995), Den Dikken (2003), and Vikner (2005), who discusses similar cases for German. In (31), we provide examples with the verb (*her*)*invoeren*. Bennis (1993) reports that some speakers consider examples like (31b’&c’) marginally acceptable, and [taaladvies.net/taal/advies/vraag/377](http://taaladvies.net/taal/advies/vraag/377) reports that the split patterns occurs in Belgium.

- (31) a. dat hij die regel invoert. a’. dat hij die regel herinvoert.  
 that he that rule prt.-introduces that he that rule reintroduces  
 ‘that he introduces that rule.’ ‘that he reintroduces that rule.’  
 b. Hij voert die regel in. b’. <sup>??</sup>Hij voert de regel herin.  
 c. \*Hij invoert die regel. c’. <sup>\*??</sup>Hij herinvoert die regel.

The discussion above strongly suggests that there is a set of verbal (X+V) collocations that resist verb-second; following Vikner (2005), we will refer to such collocations as IMMOBILE VERBS. The fact that it is not difficult to find cases such as (29b) and (30b) on the internet suggests, however, that collocations like *touwtje springen* and *stijl dansen* are sometimes also treated as separable or compound verb forms. This raises the question as to whether we are dealing with a syntactic/morphological restriction or whether some other restriction is involved. For example, it might be the case that verb-second is syntactically possible but restricted for some reason to cases in which the speaker cannot resort to the *aan het* +  $V_{\text{infinitive}}$  construction, as might be the case in the examples in (28), or that verb-second is restricted to sports jargon, that is, used by individual speakers who are involved with the activity denoted by the collocation in question on a more regular basis.

In order to shed more light on this issue, the following subsections will investigate the properties of verbal collocations in more detail. Our point of departure will be that such collocations can be divided into the three main types in (32): inseparable collocations are compounds that undergo verb-second as a whole, separable collocations are phrase-like constructions that split under verb-second, and immobile collocations tend to resist verb-second.

- (32) a. Inseparable verbal collocations (compounds): *bek<sub>N</sub> + vechten* ‘to squabble’, *lief<sub>A</sub> + kozen* ‘to fondle’, *hoeste<sub>V</sub> + proesten* ‘to cough and splutter’  
 b. Separable verbal collocations: *adem<sub>N</sub> + halen* ‘to breathe’, *piano<sub>N</sub> + spelen* ‘to play the piano’, *paard<sub>N</sub> + rijden* ‘to ride (on horseback)’  
 c. Immobile verbal collocations: *touwtje<sub>N</sub> + springen* ‘to (rope) skip’, *stijl<sub>N</sub> + dansen* ‘to ballroom dance’, *zweef<sub>V</sub> + vliegen* ‘to glide (in a sailplane)’

Subsections I-V investigate the properties of inseparable and separable verbal collocations. We will show that the set of verbs that are traditionally assumed to be separable is in fact not a unitary class but falls apart in at least two subgroups, one of which is separable under verb-second and another which is not; the latter group will be shown to be immobile in the sense of Vikner (2005). Subsection V concludes this part of the discussion with an attempt at an analysis. The results of the investigation in Subsection I-V will be applied to various types of immobile verbs: Subsections VI-VIII focus on three different subtypes of immobile N+V collocations while Subsection IX investigates inseparable complex particle verbs; Subsection X concludes with a brief discussion of a type of immobile verb that has received relatively little attention in the literature so far.

### *I. Separable and inseparable verbal collocations*

This subsection discusses verbal collocations with a noun, adjective or a verb as their first member. Generally speaking, we find two syntactically relevant types: inseparable and separable collocations. It seems that this distinction weakly correlates with the semantic/syntactic status of the left-hand member, as Ackema (1999) notes that in separable collocations the left-hand member is normally an argument of the verbal part. This is illustrated in (33). The verb *vechten* ‘to fight’ in (33a) is intransitive and N-part *bek* ‘mouth’ is interpreted as having the semantic role of instrument; cf. *met de bek vechten* ‘to fight with the mouth’. The verb *halen* ‘to get’ in (33b) is transitive and the N-part *adem* ‘breath’ is interpreted as a theme argument. The primed examples show that only in the latter case can the N+V collocation be split.

- (33) a. *dat deze jongens voortdurend bek vechten.* [inseparable/compound]  
 that these boys continuously mouth fight  
 ‘that these boys squabble continuously.’  
 a'. *Deze jongens <bek> vechten voortdurend <\*bek>.*  
 these boys mouth fight continuously  
 b. *dat de patiënt moeilijk adem haalt.* [separable]  
 that the patient with.difficulty breath takes  
 ‘that the patient is breathing with difficulty.’  
 b'. *De patiënt <\*adem> haalt moeilijk <adem>.*  
 the patient breath takes with.difficulty

In (34), we provide a sample of the two types of N+V collocation, based on De Haas & Trommelen (1993) and Booij (2010). We do not include inseparable verbs such as *voetballen* ‘to play soccer’ that are (potentially) derived via °conversion from complex nouns (here: *voetbal* ‘football’) or formations like *raadplegen* ‘to consult’ with a non-transparent or non-compositional meaning for present-day speakers because these are expected to be inseparable anyway. Recall that we diverge from the orthographic convention to write the N+V collocations in (34b) as a single word in order not to bias the discussion below towards a compound analysis for these collocations.

- (34) • N+V collocations
- a. Inseparable: *beeldhouwen* ‘to sculpture’, *bekvechten* ‘to squabble’, *rangschikken* ‘to group’, *redetwisten* ‘to argue’, *slaapwandelen* ‘to walk in one’s sleep’, *zegevieren* ‘to triumph’
  - b. Separable: *adem halen* ‘to breathe’, *auto rijden* ‘to drive a car’, *brand stichten* ‘to raise a fire’, *deel nemen* ‘to participate’, *dienst weigeren* ‘to refuse conscription’, *feest vieren* ‘to celebrate’, *kaart lezen* ‘to read maps’, *koffie zetten* ‘to make coffee’, *les geven* ‘to teach’, *piano spelen* ‘to play the piano’, *recht spreken* ‘to administer justice’, *ruzie maken* ‘to quarrel’, *televisie kijken* ‘to watch television’

Note that we used the notion “weak correlation” in order to characterize Ackema’s hypothesis. The reason is that it is not the case that N+V collocations are always separable if the N-part functions as a theme. This can be readily illustrated by means of the collocation *stof zuigen* ‘to vacuum’, which can be used either as a separable or as an inseparable collocation by many speakers. There is reason, however, for assuming that the N-part has lost its argument status in the inseparable form; see Ackema (1999) and the discussion of the examples in (44) in Subsection II.

- (35) a. dat Jan elke week stof zuigt.  
that Jan every week dust sucks  
‘that Jan vacuums every week.’
- b. Jan <stof> zuigt elke week <stof>.  
Jan dust sucks every week

We should further raise a warning flag and note that there are a number of cases of separable N+V collocations for which it is less clear that the N-part functions as a (direct) argument of the V-part. This holds for, e.g., *piano spelen* ‘to play the piano’ and *televisie kijken* ‘to watch television’, given that *spelen* and *kijken* select a PP-complement in examples such as (36). In order to maintain the claim that the N-part is an argument of the V-part, we have to assume that the PP-complement is reduced in the separable N+V collocations *piano spelen* and *televisie kijken*; see Ackema (1999) and Booij (2010) for a discussion of these forms.

- (36) a. Jan speelt \*(op) een Steinway.  
Jan plays on a Steinway  
‘Jan is playing on a Steinway.’

- b. Jan kijkt \*(naar) de televisie.  
 Jan looks at the television  
 'Jan is looking at the television.'

The examples in (37) illustrate that the two main types can also be found in the case of A+V collocations: (37a) is an example with the inseparable (compound) verb *liefkozen* 'to fondle' and (37b) with the separable collocation *bekend maken* 'to make known'.

- (37) a. dat Jan zijn hond vaak liefkoost. [inseparable/compound]  
 that Jan his dog often fondles  
 'that Jan often fondles his dog.'
- a'. Jan <lief>koost zijn hond vaak <\*lief>.  
 Jan fondles his dog often
- b. dat Jan zijn besluit morgen bekend maakt. [separable]  
 that Jan his decision tomorrow known makes  
 'that Jan will make his decision public tomorrow.'
- b'. Jan <\*bekend> maakt zijn beslissing morgen <bekend>.  
 Jan known makes his decision tomorrow

When we exclude examples such as *blinddoeken* 'to blindfold', which is derived from the complex noun *blinddoek* 'blindfold', and cases such as *dwarzbomen* 'to thwart' with a non-transparent or non-compositional meaning for the present-day speaker, there are very few inseparable A+V collocations; the examples in (38a) are again taken from De Haas & Trommelen (1993). For the separable A+N collocations in (38b), Ackema's hypothesis that the left-hand member of the collocation is normally an argument of the verbal part of the collocation seems too strict, but we can easily repair this by loosening the statement slightly by requiring that the left-hand member must be a °complement of the verbal part, as this will also include °complementives. Again, we diverge from the orthographic convention to write separable A+V collocations as separate words in order not to bias the discussion below towards a compound analysis for these collocations.

- (38) • A+V collocations
- a. Inseparable: *fijnproeven* 'to test the taste of something', *liefkozen* 'to fondle'
- b. Separable: *dood zwijgen* 'to hush up/smother', *droog leggen* 'to reclaim/impolder', *dwars liggen* 'to be contrary', *fijn malen* 'to grind', *goed keuren* 'to approve', *groot brengen* 'to bring up', *klaar komen* 'to complete one's work/have an orgasm', *los breken* 'to break loose', *stuk lezen* 'read to pieces', *vol gieten* 'to fill up', *vreemd gaan* 'to be unfaithful', *wit wassen* 'to launder (black money)', *zwart maken* 'to blacken'

The proposed revision of Ackema's hypothesis, which we will from now on refer to as Ackema's generalization, also accounts for the fact that particle verbs (P+V collocations) like *opbellen* 'to call up' and *overstromen* 'to run over' in (39) are normally separable because Section 2.2 has shown that verbal particles also function as complementives. Although there are a number of inseparable P+V collocations, we will not digress on this here, as this would simply repeat the



discussion in Section P1.2.4.4. We will in fact ignore P+V collocations altogether until we return to them in Subsection IX.

- (39) a. Jan belde me op.  
 Jan called me up  
 b. De emmer stroomde over.  
 the bucket ran over  
 ‘The bucket overflowed.’

There are very few inseparable V+V collocations like *hoesteproesten* ‘to cough and splutter’ in (40a); more transparent cases such as *zweefvliegen* ‘to glide (in a sailplane)’ belong to the set of immobile collocations, which will be discussed in Subsection IV. Separable V+V collocations are also rare and may in fact not exist at all: a potential case is *laten vallen* ‘to drop’ in (40b), but the fact that the dependent verb *vallen* ‘to fall’ does not precede but follows the causative verb *laten* ‘to make/let’ suggests that we are not dealing with a verbal collocation but with a regular causative *laten*-construction. We therefore will not discuss such cases here but in Section 5.2.3.4.

- (40) a. dat Jan voortdurend hoesteproest. [inseparable/compound]  
 that Jan continuously splutters  
 ‘that Jan is continuously coughing and spluttering.’  
 a’. Jan hoesteproest voortdurend.  
 Jan splutters continuously  
 b. dat Jan de theepot liet vallen. [causative *laten*-construction]  
 that Jan the teapot let fall  
 ‘that Jan dropped the teapot.’  
 b’. Jan liet de theepot vallen.  
 Jan let the teapot fall

This subsection has shown that separable verbal collocations require their first member to function as a complement of the verbal part: the N-part in N+V collocations has the function of a direct (and sometimes prepositional) object of the V-part, and the A-part in A+N collocations functions as a complementive, that is, a predicative complement of the V-part. Since there are no clear cases of separable V+V collocations and since particle verbs are discussed separately in Subsection IX, the following subsections will be concerned with N+V and A+V collocations.

## II. Differences between separable and inseparable verbal collocations

On the assumption that inseparable X+V collocations are true compounds, their syntactic behavior can be accounted for by appealing to the °lexical integrity constraint, according to which syntactic operations cannot apply to subparts of words. An inseparable N+V collocation like *bekvechten* ‘to squabble’ should then be analyzed as [<sub>v</sub> bekvechten], in which the label V° stands for a word boundary. By the same logic, separable N+V collocations cannot be analyzed as compounds but should be phrasal in nature: a separable N+V collocation like *adem halen* should then be analyzed as [<sub>v</sub> adem [<sub>v</sub> halen]], in which the label V’ stands for some phrasal projection of the verb that contains a direct object.



There is morphological and syntactic evidence in favor of this distinction. First, we would expect inflectional material to attach at the V°- and not at the V'-level, and thus we predict that the nominal part follows preverbal inflectional material in the case of (inseparable) compound verbs but precedes such material in the case of (separable) phrasal collocations. The examples in (41) shows that this prediction is correct: the preverbal part of the participial °circumfix *ge-...-d/t* and the infinitival prefix *te* must precede the nominal part in *bekvechten* but must follow it in *adem halen* for most speakers.

- (41) a. De jongens hebben de hele dag *gebekvecht*/\**bek gevecht*.  
 the boys have the whole day squabbled  
 'The boys have squabbled all day.'
- a'. De jongens liepen de hele dag *te bekvechten*/\**bek te vechten*.  
 the boys walked the whole day to squabble  
 'The boys were squabbling all day.'
- b. Jan heeft twee keer diep adem *gehaald*/\**geademhaald*.  
 Jan has two time deep breath taken  
 'Jan has taken a deep breath twice.'
- b'. Jan probeerde diep adem *te halen*/\**te ademhalen*.  
 Jan tried deep breath to take  
 'Jan tried to take a deep breath.'

Note in passing that there seems to be some variation among speakers, especially with regard to the infinitival marker *te*. For example, a Google search (11/5/2013) showed that the form *bek te vechten* is occasionally used on the internet (perhaps in jest), whereas we did not get any hits for the strings [*heb bekgevecht*] and [*heb \*bekgevecht*], in which the asterisk functions as a wild card. Similarly, the form *te ademhalen* is not difficult to find (albeit with a far lower frequency than *adem te halen*), whereas we found only a handful of genuine cases with the form *geademhaald*. The judgments in (41) reflect our own acceptability judgments and may thus be an idealization of the actual situation in Standard Dutch.

The form of the past participle *gebekvecht* in (41a) constitutes an additional argument in favor of a compound analysis, given that the participle of the simplex verb *vechten* has the irregular form *gevochten*. De Haas & Trommelen (1993:441) claim that a hallmark of compounds is that they have a regular declension; this is illustrated again in (42), in which *glimlachen* is an inseparable N+V compound and *paard rijden* is separable phrasal N+V collocation; only in the former case does the collocation have the regular declension *ge-...-d/t*.

- (42) a. lachen — *gelach-en* [inseparable]  
 laugh laughed
- a'. glimlachen — *geglumlach-t*  
 smile smiled
- b. rijden — *gered-en* [separable]  
 ride ridden
- b'. paard rijden — paard *gered-en*  
 horseback ride horseback ridden

A rather spectacular illustration of De Haas & Trommelen's claim is *stof zuigen*. The examples in (35) have shown that this collocation exhibits mixed behavior for many speakers: the N+V collocation can be split under verb-second, but it can also be moved as a whole. The simplex verb *zuigen* 'to suck' has an irregular declension: *zuig-zoog-gezogen*. The predictions made by De Haas & Trommelen's hypothesis are clear. First, we predict that *stof zuigen* 'to vacuum' is associated with two past participial forms, depending on the position of the nominal part. The primeless examples in (43) illustrate that this prediction is indeed correct. Second, we predict that the split under verb-second is possible only if the finite verb has the irregular declension; the primed examples show that this predication is also correct.

- (43) a. Jan heeft gisteren stof gezogen/\*gezuigd.  
 Jan has yesterday dust sucked  
 'Jan vacuumed yesterday.'
- a'. Jan zoog/\*zuigde gisteren stof.  
 Jan sucked yesterday dust
- b. Jan heeft gisteren gestofzuigd/\*gestofzogen.  
 Jan has yesterday dust.sucked  
 'Jan vacuumed yesterday.'
- b'. Jan stofzuigde/\*stofzoog gisteren.  
 Jan dust.sucked yesterday

Note in passing that we have ignored the fact that the form *stofzoog* is occasionally found in second position on the internet, which is in fact to be expected given that speakers are quite uncertain about the "correct" form of the past tense, as is clear from the fact that it is a recurring topic of discussion on the internet. Note that there is also normative pressure to use the inseparable form, as is clear from the fact that [taaladvies.net/taal/advies/vraag/755](http://taaladvies.net/taal/advies/vraag/755) and the Van Dale Dictionary only give the regular declension.

The claim that *stof zuigen* allows two different analyses is also confirmed by the examples in (44), adapted from De Haas & Trommelen (1993:442). These examples show that this collocation can be used with the direct object *de kamer* 'the room' when it has a regular declension, but not when it has an irregular declension.

- (44) a. dat Jan de kamer stofzuigt/\*stof zoog.  
 that Jan the room dust.sucks/dust sucks  
 'that Jan is vacuuming the room.'
- b. dat Jan de kamer heeft gestofzuigd/\*stof gezogen.  
 that Jan the room has dust.sucked/dust sucked  
 'that Jan has vacuumed the room.'

This contrast follows immediately on the analysis proposed above: if *stof zuigen* is phrasal, the bare noun *stof* functions as a direct object, and thus blocks the addition of another direct object such as *de kamer* 'the room': if it is a compound, however, it might simply be stored in the lexicon as a transitive verb, and, consequently, the use of a direct object such as *de kamer* is fully licit. Other cases of such transitive, inseparable N + V collocations mentioned by Ackema (1999) are: *beeldhouwen* 'to sculpture' (lit: statue + chop) stand *hersenspoelen* 'to brainwash'.

In (45) we provide similar examples for A+V collocations: *liefkozen* ‘to fondle’ (lit.: sweet + caress) is a compound and the adjectival part *lief* must therefore follow the preverbal part of the participial circumfix *ge-...-d/t* and the infinitival prefix *te*; *bekend maken* ‘to make public’, on the other hand, is phrasal and the adjectival part must therefore precede these elements.

- (45) a. Jan heeft zijn hond de hele dag liefkoosd/\*liefgekoosd.  
 Jan has his dog the whole day fondled  
 ‘Jan has fondled his dog all day.’
- a’. Jan zit zijn hond de hele dag te liefkozen/\*lief te kozen.  
 Jan sits his dog the whole day to fondle  
 ‘Jan has been fondling his dog all day.’
- b. Jan heeft zijn beslissing bekend gemaakt/\*gebekendmaakt.  
 Jan has his decision known made  
 ‘Jan has made his decision public.’
- b’. Jan weigert zijn beslissing bekend te maken/\*te bekend maken.  
 Jan refuses his decision known to make  
 ‘Jan refuses to make his decision public.’

This subsection has shown that there are reasons for assuming that inseparable verbal collocations are compounds whereas separable verbal collocations are phrasal in nature. The reasons for assuming this are mainly morphological in nature. The first involves the placement of the (preverbal part of) the inflectional affixes *ge-...-d/t* and *te*. The second is that the inseparable verbal collocations always have a regular declension, which has been claimed to be a hallmark of compounds; the declension of the verbal part of separable verbal collocations, on the other hand, is fully determined by the verbal part.

*Table 1: Differences between inseparable and separable verbal collocations*

	INSEPARABLE	SEPARABLE
PARTICIPIAL AFFIX	<i>ge-X+V-d/t</i>	<i>X ge-V-d/t</i>
INFINITIVAL PREFIX	<i>te X+V</i>	<i>X te V</i>
DECLENSION	always regular	depends on verbal part

### *III. Similarities between separable and inseparable N+V collocations*

Although the discussion in Subsection II strongly suggests that separable N+V collocations are phrasal and that the N-part normally functions as a direct (or, perhaps, a prepositional) object of the V-part, the collocation has a number of properties normally not found with verb phrases consisting of a verb and an object. With regard to these peculiarities, separable N+V collocations rather behave like N+V compounds. We will illustrate this compound-like behavior of separable N+V collocations by comparing the separable collocations *adem halen* ‘to breathe’ and *piano spelen* ‘to play the piano’ with the regular verb phrase *iets halen* ‘to fetch something’ and *iets spelen* ‘to play something (e.g., a sonata)’.

A first property is that the N-part of a separable N+V collocation is normally bare, that is, not accompanied by a determiner, whereas singular regular direct

objects are normally not bare, that is, they require a determiner. Notice that this difference is not observable if the N-part is plural, as in *aardappels schillen* ‘to peel potatoes’, given that indefinite plurals take a phonetically empty article.

- (46) a. dat Jan (\*een) adem haalt.      b. dat Marie (\*de) piano speelt.  
that Jan a breath gets                      that Marie the piano plays  
‘that Jan is breathing.’                      ‘that Marie is playing the piano.’  
a’. dat Jan \*(een) boek haalt.      b’. dat Marie \*(de) sonate speelt.  
that Jan a book gets                      that Marie the sonata plays  
‘that Jan is fetching a book.’                      ‘that Marie is playing the sonata.’

Related to this difference concerning the determiner is the fact that the nominal part of the N+V collocation is not referential. This can be shown by comparing the examples in (47): example (47a) cannot be uttered out of the blue given that the reference of the deictic pronoun *hij* cannot be properly determined by the bare noun *piano*; example (47b) with the regular direct object *de sonate* ‘the sonata’, on the other hand, is fine since the pronoun can take this object as its antecedent.

- (47) a. <sup>s</sup>dat Jan niet graag piano speelt, want hij is vals.  
that Jan not gladly piano plays, because he is off-key  
‘that Jan doesn’t like to play the piano, because it is off-key.’  
b. dat Jan niet graag de sonate speelt, want hij is te moeilijk.  
that Jan not gladly the sonata plays because he is too difficult  
‘that Jan doesn’t like to play the sonata, because it is too difficult.’

For the same reason it is normally impossible to modify the nominal part of an N+V collocation by an attributively used adjective, whereas this is, of course, possible with regular direct objects, as shown by the examples in (48).

- (48) a. dat Jan niet graag (\*nieuwe) piano speelt  
that Jan not gladly new piano plays  
b. dat Jan niet graag de (nieuwe) sonate speelt.  
that Jan not gladly the new sonata plays  
‘that Jan doesn’t like to play the new sonata.’

In passing, it should be noted that attributive modification of the nominal part of a separable N+A collocation is marginally possible if the modifier-noun combination has a type reading: Booij (2010), for example, provides examples such as *dat Jan klassieke piano speelt*. However, the fact that Booij translates this example as “that John plays classical piano music” suggests that we may simply be dealing with a regular direct object in the form of a mass noun, comparable to *Hij speelt klassieke muziek/jazz* ‘He plays classical music/jazz’. We will leave this issue for future research and simply conclude from the examples above that nominal parts of N+V collocations are not referential. In this respect they are similar to the first members of N+V compounds like *beeldhouwen* ‘to sculpture’, N+A compounds like *boterzacht* ‘soft as butter’, and N+N compounds like *huissleutel* ‘latchkey’, but unlike regular direct objects.

A second property of the N-part of separable N+V collocations is that speakers allow them to permeate clause-final °verb clusters. This is, of course, obligatory for

the nominal parts of N+V compounds, but for regular direct objects this is allowed by a subset of Flemish speakers only; see Sections 5.2.3 and 6.2, and Barbiers (2008:ch.2).

- (49) a. dat Jan diep <adem> moet <adem> halen.  
 that Jan deeply breath must get  
 'that Jan must breathe deeply.'
- a'. dat Jan <een boek> moet <% een boek> halen.  
 that Jan a book must get  
 'that Jan must fetch a book'
- b. dat Marie graag <piano> wil <piano> spelen.  
 that Marie gladly piano want play  
 'that Marie is eager to play the piano.'
- b'. dat Marie graag <de sonate> wil <% de sonate> spelen.  
 that Marie gladly the sonata want play  
 'that Marie is eager to play the sonata.'

A third property of the N-part of a separable N+V collocation is that it can be left-adjacent to the main verb in the progressive *aan het* +  $V_{\text{infinitive}}$  construction; regular direct objects, on the other hand, must precede the *aan het* +  $V_{\text{infinitive}}$  phrase.

- (50) a. Jan is verkeerd <adem> aan het <adem> halen.  
 Jan is wrongly breath AAN HET get  
 'Jan is breathing in the wrong way.'
- a'. Jan is <een boek> aan het <\*een boek> halen.  
 Jan is a book AAN HET get  
 'Jan is fetching a book.'
- b. Marie is <piano> aan het <piano> spelen.  
 Marie is piano AAN HET play  
 'Marie is playing the piano.'
- b'. Marie is <de sonate> aan het <\*de sonate> spelen.  
 Marie is the sonata AAN HET play  
 'Marie is playing the sonata.'

A final property in which N-parts of separable N+V collocations differ from regular direct objects is that they cannot easily occur as part of a postnominal *van*-PP in nominalizations, as is illustrated in (51).

- (51) a. [Het halen van een boek/??adem] is gemakkelijk.  
 the getting of a book/breath is easy  
 'Getting a book is easy.'
- b. [Het spelen van een sonate/??piano] is niet gemakkelijk.  
 the playing of a sonata/piano is not easy  
 'Playing of a sonata isn't easy.'

The discussion above has shown that the N-part of N+V collocation has various properties that are unexpected for regular direct objects but resemble the properties of the N-part of a N+V compound: (i) it is not referential, (ii) it is allowed to interrupt clause-final verb clusters, and (iii) it can be left-adjacent to the main verb

in the progressive *aan het* +  $V_{\text{infinitive}}$  construction. The first property is, of course, inapplicable to A+V collocations, but the examples in (52) show for *fijn malen* ‘to grind’ that the latter two properties can also be established for such cases.

- (52) a. dat Jan de peper <fijn> moet <fijn> malen.  
 that Jan the pepper to.a.powder must grind  
 ‘that Jan must grind the pepper.’  
 b. that Jan de peper <fijn> aan het <fijn> malen is.  
 that Jan the pepper to.a.powder AAN HET grind is  
 ‘that Jan is grinding the pepper.’

The findings from our discussion above are summarized in Table 2.

Table 2: Similarities between inseparable and separable verbal collocations

	INSEPARABLE	SEPARABLE
N IS REFERENTIAL	no	no
VERBAL CLUSTERS	V X $V_{\text{main}}$	V X $V_{\text{main}}$ or X V $V_{\text{main}}$
AAN HET-CONSTRUCTION	aan het X $V_{\text{main}}$	aan het X $V_{\text{main}}$ or X aan het $V_{\text{main}}$

#### IV. Immobile verbal collocations (1): introduction

Table 2 shows that separable X+V collocations like (34b) and (38b) exhibit variable behavior with respect to the placement of the X-part vis-à-vis the verbal part in constructions with a clause-final verb cluster or a progressive *aan het*-phrase. This raises the question as to whether it is justified to consider separable X+V collocations as a single class, or whether we should distinguish two subtypes. This question has been investigated for N+V collocations, and it seems that there is reason for assuming the latter; see Booij (2010: Section 4.3). The argument is based on the morphological expression of sentence negation. In Dutch, sentence negation can be expressed by means of the independent negative adverb *niet* ‘not’, as in (53a), but it is often obligatorily merged with some existentially quantified element in the clause, as is illustrated in (53b&c). Here, negation is expressed on, respectively, a frequency adverb (NEG + *ooit* → *nooit* ‘never’) and an indefinite direct object (NEG + *een auto* → *geen auto* ‘no car’).

- (53) a. Peter kan niet komen.  
 Peter is.able not come  
 ‘Peter can’t come.’  
 b. Peter kan nooit/\*niet ooit komen.  
 Peter is.able never/not some.time come  
 ‘Peter is never able to come.’  
 c. Peter kan geen auto/\*niet een auto kopen.  
 Peter is.able no car/not a car buy  
 ‘Peter can’t buy a car.’

The examples in (54) further show that the merger of sentence negation is optional in the case of N+V collocations like *auto rijden* ‘to drive a car’ and *piano spelen* ‘to play the piano’; it can either be expressed by means of the adverb *niet* ‘not’ or be expressed by the negative article *geen* ‘no’.

- (54) a. Peter kan niet/geen auto rijden.  
 Peter be.able not/no car drive  
 ‘Peter isn’t able to drive a car.’
- b. Peter kan niet/geen piano spelen.  
 Peter be.able not/no piano play  
 ‘Peter isn’t able to play the piano.’

The examples in (55) show that the choice between the two options depends on the placement of the N-part of the collocation in clauses with a verb cluster: negation seems preferably expressed by means of the negative article *geen*, but if the N-part remains adjacent to the V-part the negative adverb *niet* must be used. Although Booij considers the options marked with a number sign acceptable, there may be reasons for rejecting his claim; we postpone the discussion of this to Subsection V.

- (55) a. dat Peter geen/#niet auto kan rijden.  
 that Peter no/not car be.able drive  
 ‘that Peter isn’t able to drive a car.’
- a’. dat Peter niet/\*geen kan auto rijden.  
 that Peter not/no be.able car drive  
 ‘that Peter can’t drive a car.’
- b. dat Peter geen/#niet piano kan spelen.  
 that Peter no/not piano be.able play  
 ‘that Peter isn’t able to play the piano.’
- b’. dat Peter niet/\*geen kan piano spelen.  
 that Peter not/no be.able piano play  
 ‘that Peter can’t play the piano.’

The same seems to hold for the progressive *aan het* +  $V_{\text{infinitive}}$  constructions in (56). Although such negated examples are extremely rare on the internet, they seem to be fully acceptable in contrastive contexts. The options marked with the number sign also occur on the internet in contrastive contexts; this need not surprise us given that the merger of sentence negation is normally not obligatory in contrastive contexts: cf. *Ik heb niet een auto, maar een fiets gekocht* ‘I have not bought a car, but a bicycle’.

- (56) a. Peter is geen/#niet auto aan het rijden (maar aan het fietsen).  
 Peter is no/not car AAN HET drive but AAN HET cycle  
 ‘Peter isn’t driving (but he’s gone cycling).’
- a’. Peter is niet/\*geen aan het auto rijden (maar aan het fietsen).  
 Peter is not/no AAN HET car drive but AAN HET cycle  
 ‘Peter isn’t driving (but he’s gone cycling).’
- b. Peter is geen/#niet piano aan het spelen (maar aan het lezen).  
 Peter is no/not piano AAN HET play but AAN HET read  
 ‘Peter isn’t playing the piano (but he’s reading a book).’
- b’. Peter is niet/\*geen aan het piano spelen (maar aan het lezen).  
 Peter is not/no AAN HET piano play but AAN HET read  
 ‘Peter isn’t playing the piano (but he’s reading a book).’



As such, the examples in (55) and (56) do not shed any light on the question as to whether separable verbal collocations form a single class, or whether we should distinguish two subtypes: the merger of sentence negation may simply be subject to some adjacency restriction, which would effectively block the formation of *geen* in the primed examples. However, these examples are quite revealing in combination with the examples in (57), in which the N+V collocations are split by means of verb-second and sentential negation must be expressed by means of the negative article *geen*; the use of the adverb *niet* leads to ungrammaticality.

- (57) a. Peter rijdt geen/\*niet auto  
 Peter drives no/not car  
 ‘Peter doesn’t drive a car.’
- b. Peter speelt geen/\*niet piano.  
 Peter plays no/not piano  
 ‘Peter doesn’t play the piano.’

The fact that sentence negation cannot be expressed by means of the adverb *niet* but must be expressed by means of the merged form *geen* suggests that these verb-second examples are more akin to the primeless than to the primed examples in (55) and (56); merger of negation is restricted to those cases in which the N+V collocation can be split by syntactic operations like verb clustering and verb-second. This suggests that separable verbal collocations like (34b) and (38b) actually have two uses: they may be separable *in all syntactic and morphological contexts* or they may be separable *in morphological contexts only*. It is the latter set of separable verbs that we have characterized as immobile in the sense that they resist verb-second. This line of reasoning would result in the three groups of X+V collocations in Table 3; we have illustrated the clustering of properties on the basis of N+V collocations only, but it seems reasonable to assume that they also hold for A+V collocations.

Table 3: Types of verbal collocations

		MOBILE		IMMOBILE
		INSEPARABLE (COMPOUND)	SEPARABLE (SPLIT PATTERN: X ... V)	
A	PARTICIPIAL AFFIX	<i>ge-X+V-d/t</i>	X <i>ge-V-d/t</i>	X <i>ge-V-d/t</i>
	INFINITIVAL PREFIX	<i>te X+V</i>	X <i>te V</i>	X <i>te V</i>
B	VERBAL CLUSTERS	V X V <sub>main</sub>	X V V <sub>main</sub>	V X V <sub>main</sub>
	AAN HET-PHRASE	<i>aan het X V<sub>main</sub></i>	X <i>aan het V<sub>main</sub></i>	<i>aan het X V<sub>main</sub></i>
	NEGATION	<i>niet</i> ‘not’	<i>geen</i> ‘no’	<i>niet</i> ‘not’
C	VERB-SECOND	+ (non-split pattern)	+ (split pattern)	—

The morphological properties given in the A-rows of Table 3 distinguish the inseparable verbal compounds from the separable verbal collocations; whereas the former require that the X- and the V-part be adjacent in past/passive participles and *te*-infinitives, the latter do not allow this. The properties in the B-rows are the crucial ones for distinguishing the two types of separable verbal collocations. The C-row indicates the verb-second behavior of the three types of verbal collocations we have distinguished on the basis of the properties in A and B.



The discussion in this subsection involved separable V+X collocations that are ambiguous between a mobile and an immobile form. Subsections VI-IX will discuss cases of verbal collocations that are (normally) of the immobile type: we will successively discuss immobile verbs of the type *touwtje springen* 'to skip' (lit: to rope skip), *stijl dansen* 'to ballroom dance' (lit.: to style dance), and *herinvoeren* 'to reintroduce'. In subsection V, however, we first attempt to sketch a theoretical account of the clustering of the properties in Table 3.

#### *V. Immobile verbal collocations (2): a theoretical excursion*

The first group of X+V collocations in Table 3 is the class of compounds, which differs from the other two groups in that the X+V collocations form an indissoluble morphological and syntactic unit. In short, they function as complex words of the form [<sub>V</sub> X V]: inflectional material is added externally to V<sup>o</sup>, which accounts for their properties in the two A-rows in Table 3, and syntactic movements may only affect V<sup>o</sup> as a whole, which accounts for their properties in the B- and C-rows.

The original class of separable X+V collocations is now divided into two subgroups which have in common that the X-part can be separated from the verbal part by inflectional morphemes. This strongly suggests that we are dealing with a regular verb phrase, [<sub>V</sub> X V<sup>o</sup>], in which N functions as a direct object and A functions as a complementive: inflectional material is consequently added to V<sup>o</sup>, which again accounts for their properties in the A-rows in Table 3.

The claim that separable X+V collocations involve regular verb phrases of the form [<sub>V</sub> X V<sup>o</sup>] also accounts for the properties of the first subgroup of separable verbs in the B- and C-rows in Table 3: (i) the fact that the X-part is syntactically independent from the verbal part of the collocation predicts that these parts need not remain adjacent in syntax but can be split by syntactic operations like movement (especially those involved in the formation of verb clusters and the derivation of verb-second), and (ii) the fact that the N-part is in the regular object position accounts for the fact that the merger of sentence negation and the indefinite article (*geen* 'no') is obligatory.

This leaves us with the second group of separable verbs, which do behave as a unit for syntactic purposes. It has been proposed that these involve INCORPORATION, a syntactic operation creating a syntactic unit by means of so-called head °adjunction. This changes the phrase structure [<sub>V</sub> X V] via head movement of the X into the structure [<sub>V</sub> t<sub>X</sub> [<sub>V\*</sub> X V]], in which V\* stands for a syntactically derived complex head. In some languages noun incorporation is much more productive than in Dutch, and Baker (1988) has shown for such languages that incorporation is restricted to complements; this provides a natural cross-linguistic rationale for Ackema's generalization. The incorporation analysis also derives the properties in the (B)-columns in Table 3: (i) although the collocation can be split by morphological operations, this cannot be done by syntactic operations involved in the creation of verb clusters or *aan het*-phrases, and (ii) the premise that the N-part is no longer in object position after incorporation can now be held responsible for the impossibility of the merger of sentence negation. It remains mysterious, however, why this type of separable X+V collocation cannot undergo verb-second. It has been suggested that the reason for this is that verb-second can only affect

words, that is, V°s: since V° cannot be extracted from V\* and V\* cannot undergo verb-second itself, the impossibility of verb-second follows. What is, of course, still needed in such an approach is a believable account of the observation that V\*’s cannot undergo verb-second; this is currently under investigation and we refer the reader to Koopman (1995), Vikner (2005) and Booij (2010) for various attempts to provide an explanation for this.

If the discussion above is on the right track, we can identify the three types of verbal collocation by their different kinds of verbal element: true compounds ([V° X V]), phrasal projections ([V° X V°]), and word-like V\*-units ([V\* X V°]) derived by incorporation. This makes it possible to replace Table 3 by Table 4.

Table 4: Types of verbal collocations

		[V° X V]	[V° X V°]	[V* X V°]
A	PARTICIPIAL AFFIX	<i>ge-X+V-d/t</i>	<i>X ge-V-d/t</i>	<i>X ge-V-d/t</i>
	INFINITIVAL PREFIX	<i>te X+V</i>	<i>X te V</i>	<i>X te V</i>
B	VERBAL CLUSTERS	<i>V X V<sub>main</sub></i>	<i>X V V<sub>main</sub></i>	<i>V X V<sub>main</sub></i>
	AAN HET-PHRASE	<i>aan het X V<sub>main</sub></i>	<i>X aan het V<sub>main</sub></i>	<i>aan het X V<sub>main</sub></i>
	NEGATION	<i>niet ‘not’</i>	<i>geen ‘no’</i>	<i>niet ‘not’</i>
C	VERB-SECOND	+ (non-split pattern)	+ (split pattern)	—

In order to make the incorporation proposal watertight we should say something about the negation data in the primeless examples in (55), repeated here as (58). Given that the N+V collocation is split, we cannot assume that the N-part is incorporated in the V-part of the collocation. We therefore expect the N-part to be in the regular object position and, consequently, the merger of sentence negation to be obligatory; the use of *niet* should thus lead to ungrammaticality.

- (58) a. dat Peter geen/#niet auto kan rijden.  
 that Peter no/not car be.able drive  
 ‘that Peter isn’t able to drive a car.’
- b. dat Peter geen/#niet piano kan spelen.  
 that Peter no/not piano be.able play  
 ‘that Peter isn’t able to play the piano.’

That the examples with *niet* are not (fully) acceptable may find support in the fact that such examples are rare on the internet. Our Google searches (3/12/2015) on the strings [*niet auto kan rijden*] and [*niet piano kan spelen*] resulted in 54 hits. Moreover, the results include many cases in which the adverb *niet* is coordinated with the affirmative marker *wel*: given that examples such as (59) show that such coordinations block the merger of negation, these cases should be excluded, and this leaves us with no more than 20 relevant cases.

- (59) a. Heb je wel of niet een auto gekocht?  
 have you AFF or not a car bought  
 ‘Did you or did you not buy a car?’
- b. \*Heb je wel of geen auto gekocht?

Given that the corresponding search string [*geen auto kan rijden*] and [*geen piano kan spelen*] resulted in 213 hits, we might have to conclude that the uses of *niet* can be dismissed as writing errors as the relevant cases constitute about 10% of the attested cases. This would be in line with our own judgment that under neutral intonation the use of *niet* in examples such as (58) is marked compared to the use of *geen*. Recall that the restriction to neutral intonation is needed because the discussion of (56) has shown that the use of *niet* is possible in contrastive contexts.

If one considers the 20 attested cases with *niet* sufficient for maintaining that the use of *niet* leads to a grammatical result, a coherent incorporation analysis must state that the X-part can not only be incorporated in the verbal part of the collocation but also in larger verb clusters; cf. Booij (2010). This result would be relatively easy to obtain under the traditional verb-raising analysis of verb clustering: verb raising is assumed to create an adjunction structure (similar to that resulting from noun incorporation) as the result of verb movement. If we assume that the base structure of an example such as (58a) is as given in (60a), verb raising may derive a structure such as (60b) with the syntactically derived complex head [ $v^*$  kan rijden], and subsequent N-incorporation would lead to (60c). Since we have seen that N-incorporation is optional, we can now account for the fact that both *geen* and *niet* are possible in (58): in structure (60b) negation must merge with the indefinite N-part in direct object position, whereas in structure (60c) this is blocked by the fact that the N-part is part of an adjunction structure.

- (60) a. ... NEG [ $v^*$ ... [ $v'$  auto rijden] kan]  
 b. ... NEG [ $v^*$ ... [ $v'$  auto  $t_{rijden}$ ] [ $v^*$  kan rijden]] [verb raising]  
 c. ... NEG [ $v^*$ ... [ $v'$   $t_{auto}$   $t_{rijden}$ ] [ $v^*$  auto [ $v^*$  kan rijden]]] [noun incorporation]

Independent support of the claim that N-incorporation is possible into larger verb clusters may be found in the fact that examples such as (61) are at least marginally acceptable for some (but certainly not all) speakers of Dutch.

- (61) a. ?dat Peter graag zou auto willen rijden.  
 that Peter gladly would car like drive  
 'that Peter would like to drive a car.'  
 b. ?dat Peter graag zou piano willen spelen.  
 that Peter gladly would piano want play  
 'that Peter would like to play the piano.'

Under a verb-raising approach, example (61a) is derived as follows: starting from the structure in (62a) verb raising first creates the verb cluster [ $v^*$  willen rijden] in (62b); subsequent N-incorporation in this cluster results in the structure [ $v^*$  auto [ $v^*$  willen rijden]] in (62c); finally, this complex is incorporated into the finite verb by means of verb raising, resulting in [ $v^*$  zou [ $v^*$  auto [ $v^*$  willen rijden]]] in (62d). We refer the reader to Bennis (1992) for a similar derivation of verb clusters containing a particle verb in the order  $V_{finite-prt}-V_{inf}-V_{main}$ .

- (62) a. ... NEG [ $v'$  ... [ $v^*$ ... [ $v'$  auto rijden] willen] zou]  
 b. ... NEG [ $v'$  ... [ $v^*$ ... [ $v'$  auto  $t_{rijden}$ ] [ $v^*$  willen rijden]]] zou]  
 c. ... NEG [ $v'$  ... [ $v^*$ ... [ $v'$   $t_{auto}$   $t_{rijden}$ ] [ $v^*$  auto [ $v^*$  willen rijden]]]] zou]  
 d. ... NEG [ $v'$  ... [ $v^*$ ... [ $v'$   $t_{auto}$   $t_{rijden}$ ]  $t_{auto}$  willen rijden [ $v^*$  zou [ $v^*$  auto [ $v^*$  willen rijden]]]]]]

There are, however, also a number of potential problems for an approach based on noun incorporation and verb raising. A minor problem is that the rules determining the word order of the complex V\* are quite complicated: while incorporation of nouns and adjectives involves left-adjunction, incorporation of verbs would (normally) involve right-adjunction. A more serious problem is related to the account of the primeless examples in (57), one of which is repeated here as (63a).

- (63) a. Peter rijdt geen/\*niet auto  
 Peter drives no/not car  
 'Peter doesn't drive.'
- b. ... rijdt ... NEG [<sub>V</sub>... [<sub>V</sub> auto *t*<sub>rijdt</sub>]]
- c. \*.. rijdt ... NEG [<sub>V</sub>... [<sub>V</sub> *t*<sub>auto</sub> [<sub>V\*</sub> auto *t*<sub>rijdt</sub>]]]

The fact that negation must be expressed by means of *geen* in verb-second structures such as (63a) was argued to result from a constraint prohibits extraction of V° from V\*-units: since (63c) violates this constraint, (63a) must have the structure in (63b), which correctly predicts that the merger of negation with the direct object is obligatory. However, the claim that N-incorporation may also target verb clusters, needed to account for the examples in (58) marked by a number sign, presupposes that verb clusters are V\*-units ([<sub>V\*</sub> V V]) themselves. This raises the question as to how we can derive verb-second at all, given that this would always involve extraction of V° from a V\*-unit (at least under the traditional standard assumption that verb raising is obligatory). We will leave the question as to whether or not the use of the adverb *niet* gives rise to a grammatical result in examples such as (58) undecided and, consequently, it likewise remains open whether the assumption that noun incorporation into verb clusters is possible is really needed.

#### VI. Immobile verbal collocations (3): type *touwtje springen* 'to skip'

This subsection discusses X+V collocations of the type *touwtje springen* 'to skip'. The examples in (64) show that the verb *springen* 'to skip' is normally intransitive; this means that the N-part does not function as a theme of the verbal part (it has an adverbial interpretation instead).

- (64) a. \*Jan springt het rode touwtje.  
 Jan skips the red rope
- b. Jan springt met het rode touwtje.  
 Jan skips with the red rope  
 'Jan is skipping with the red rope'

Ackema's generalization that separable X+V collocations allow verb-second only if the X-part functions as a complement of the V-part thus predicts that *touwtje springen* is immobile. Our Google searches discussed in the introduction to this section have revealed that this prediction is not entirely correct. Verb-second can be found with this type of collocation but seems restricted to a number of specific contexts; it frequently occurs in headlines, headers, captions of pictures and movies, etc. Verb-second also occurs in sentences in which the collocation is used as part of a list, often in brief written reports of certain happenings. In other texts, verb-second seems relatively common in sentences with a generic or a habitual reading. In many

cases, the three uses go together. Some typical examples from the internet are given in (65).

- (65) a. Auto springt touwtje. [caption of a video]  
       car skips rope
- b. Madonna zit op een troon en toont zich als koningin aan het publiek, de diva *springt touwtje*, is in een stoeipakje heerseres van de dansvloer en [...].  
       ‘Madonna is sitting on a throne and shows herself as queen to the audience; the diva skips, dominates the dance floor in a sexy outfit, and [...].’ [report: *Algemeen Dagblad*, September 2, 2008; [ad.nl/ad.nl/1002/Showbizz/article/detail/2188758/2008/09/02/Visueel-spektakel-Madonna.dhtml](http://ad.nl/ad.nl/1002/Showbizz/article/detail/2188758/2008/09/02/Visueel-spektakel-Madonna.dhtml)]
- c. Maxwell springt touwtje zoals een rechtshandige met links gooit. [generic]  
       Maxwell skips rope like a right-handed with left throw  
       ‘Maxwell skips like a right-handed person throws with his left hand.’

These cases are somewhat special and may therefore follow somewhat different rules. Captions such as (65a) require a certain brevity, and thus disfavor the more usual but lengthier progressive *aan het* +  $V_{\text{infinitive}}$  construction. The phrase *de diva springt touwtje* in (65b) is part of a numeration of events, and verb-second may therefore be forced (or at least be favored) by some parallelism constraint on the structure. For cases such as (65a), we can certainly make a case for assuming that it should not be part of Dutch °core grammar (= the automatically acquired part of grammar) but of its periphery (= the consciously learned part of it), and perhaps the same holds for cases such as (65b). If so, the claim that verb-second of collocations like *touwtje springen* is part of core grammar should rest on generic examples such as (65c), which do not allow the progressive *aan het* +  $V_{\text{infinitive}}$  construction, and some more incidental cases (often from poems, stories and novels).

The discussion above suggests that it would be justified to assign a special status to verb-second structures with N+V collocations like *touwtje springen* in (65); in fact, this would also follow from the hypothesis proposed in subsection V that the split pattern is only compatible with the phrasal structure [ ${}_V X V^\circ$ ], in which N functions as a direct object. But this is not sufficient to exclude verb-second; if *touwtje springen* were a compound, we would wrongly expect verb-second of the full collocation [ ${}_V X V$ ]. The only remaining option therefore would be to assume that we are dealing with a word-like  $V^*$ -unit ([ ${}_V X V^\circ$ ]). We should note, however, that these  $V^*$ -units are unlikely to be the result of syntactic incorporation given that X does not function as a complement of the verb, and this again would lead us to the conclusion that N+V collocations like *touwtje springen* are not part of core syntax. We will assume therefore that these quasi-incorporation structures are simply learned on an item-to-item basis, and listed as  $V^*$ -units in the lexicon; see Booij (2010), who argues that *all*  $V^*$ -units are lexically specialized and should therefore be listed in the lexicon. Other proposals that are in line with this view can be found in Koopman (1995) and Vikner (2005). If N+V collocations of the type *touwtje springen* are indeed listed in the lexicon as  $V^*$ -units, we expect them to exhibit the properties indicated in the final column of Table 4.

Let us broaden the empirical scope of our investigation and investigate this phenomenon on the basis of the four N+V collocations in (66). These were more or less randomly chosen from the earlier-mentioned list of (mainly) N+V collocations found at taaladvies.net/taal/advies/vraag/703, although we made sure that they satisfied the following three criteria: (i) the N-part of the collocation normally precedes the past/passive participial form of the verbal part as a whole (X + *ge-V-d/t*), (ii) the N-part cannot be interpreted as the theme argument of the verbal part, and (iii) the Van Dale dictionary states that the collocations as a whole are used in their infinitival form only. Cases that do not fit these criteria will be discussed in the following subsections.

- (66) a. ballon varen  
balloon sail  
'to balloon'
- b. parachute springen  
parachute jump  
'to parachute/skydive'
- c. stelt lopen  
stilt walk  
'to walk on stilts'
- d. wad lopen  
mud.flats walk  
'to cross the mud flats'

#### A. Past/passive participles and te-infinitives

That Van Dale is wrong in claiming that these collocations only occur in their infinitival form is clear from our Google searches (11/13/2013) for past/passive participial forms. For each collocation we looked for two participial forms: X + *ge-V-d/t* and *ge-X-V-d/t*. Our search string did not have a space between the two words so as to exclude cases in which X is part of some preverbal constituent; this resulted in a lower number of hits for the form X + *ge-V-d/t* than if we had also searched for cases with a space. Duplicates or irrelevant cases were not extracted from the results, but we did check whether the desired passive/perfect-tense construction was included. As for the results for *ge-X-V-d/t*, it is often clear that either the writer was not sure which form to use or that he was joking: writers often provide both options and/or comment on the ‘‘correctness’’ of the form(s)—some of the attestations of *gewadloopt* and *geparachutespringd* (sometimes misspelled with a *t*) are found in the writer’s reflections on the use of the two forms.

#### (67) Past/passive participle forms

	X + <i>GE-V-D/T</i>	<i>GE-X-V-D/T</i>
ballon varen	ballongevaren: 92	ballongevaard: 1
parachute springen	parachutegesprongen: 87	geparachutespringd: 9
stelt lopen	steltgelopen: 11	gesteldloopt: 1
wad gelopen	wadgelopen: 244	gewadloopt: 37

The results in (67) show that the participial form can be used fairly easily provided that the X-part precedes the preverbal part of the participial °circumfix, which is also in line with our own intuitions. We are thus led to the conclusion that we are not dealing with compounds here, which in its turn predicts that the X-part should precede the infinitival marker *te*. In order to test this prediction, we also searched for the two strings [*om X te V*] and [*om te X V*] (in the latter case with and without a space between X and V). We included the infinitival complementizer *om* in our



search string in order to exclude cases in which X is part of some preverbal constituent.

(68) *Om + te* forms

	<i>OM X TE V</i>	<i>OM TE X V</i>
ballon varen	om ballon te varen: 67	om te ballonvaren: 85
parachute springen	om parachute te springen: 113	om te parachute springen: 76
stelt lopen	om stelt te lopen: 7	om te stelt lopen: 13
wad lopen	om wad te lopen: 32	om te wad lopen: 85

Interestingly, the results are now far less clear: both orders seem possible and there is sometimes even a preference for the second order. This leads us to the contradictory conclusion that the X+V collocations can be used as compounds after all.

*B. Progressive aan het + V<sub>infinitive</sub> constructions and verb clusters*

In (69) we provide the results of our Google searches concerning the progressive *aan het + V<sub>infinitive</sub>*, which we have checked manually (although the larger numbers are estimates); for the form *aan het X V* we included cases with and without a space between X and V. As is to be expected on the assumption that we are dealing with a word-like V\*-unit ([<sub>v</sub>\* X V°]), the verbal collocations normally cannot be split.

(69) Progressive *aan het + V<sub>infinitive</sub>* phrases

	<i>AAN HET X V</i>	<i>X AAN HET V</i>
ballon varen	aan het ballonvaren: 14	ballon aan het varen: 1
parachute springen	aan het parachutespringen: 45	parachute aan het springen: 12
stelt lopen	aan het steltlopen: 16	stelt aan het lopen: 0
wad lopen	aan het wadlopen: 40	wad aan het lopen: 4

Note in passing that the manual check was only possible after filtering out several frequently occurring substrings in the results (e.g., by means of the search [[*ballon aan het varen*] AND [-*de ballon*]], which resulted in potentially relevant cases without the definite noun phrase *de ballon*; this may of course have led to the improper exclusion of cases such as *Jan was ballon aan het varen toen de ballon in brand vloog* ‘Jan was making a balloon flight, when the balloon caught fire’). The same holds for some of the other manual searches discussed below.

Testing whether or not the X-part can precede clause-final verb clusters is not easy. As could be expected, our searches for the string [X MODAL V] with the singular simple present form of the modals *kunnen* ‘can’, *willen* ‘want’, *moeten* ‘must’ and *zullen* ‘will’ did not yield any results for the collocations *ballon varen* and *stelt lopen*. We found 4 cases of [*wad MODAL lopen*], which does not seem sufficient to warrant robust conclusions. There were many hits for the string [*parachute MODAL springen*], with about 55 cases of the intended construction. Unfortunately, we cannot compare absolute numbers as the results for strings of the form [MODAL X V] contain a large number of verb-second constructions.

## (70) Verb clusters

	MODAL X V	X MODAL V
ballon varen	relatively frequent	0 cases
parachute springen	relatively frequent	relatively frequent
stelt lopen	relatively frequent	0 cases
wad lopen	relatively frequent	4 cases

## C. Sentence negation

It is not easy to apply the negation test to sentences with an infinitival form because the X+V collocations under discussion can readily be nominalized (cf. *het parachutespringen*, which may refer to parachuting as such or lessons in parachuting) and such nominalizations can be preceded by the negative article *geen* 'no': cf. *We hebben vandaag geen parachutespringen* 'We will not have lessons in parachuting today'. We therefore used the search strings [*niet X + participle*] and [*geen X + participle*] with and without a space between X and the participle; the results are given in Table (71). For completeness' sake, we note that we found cases of the form [*niet/geen X te V<sub>inf</sub>*] for *parachute springen* only: we found 4 cases with *niet* and 2 with *geen*.

## (71) Sentence negation

	NIET X PARTICIPLE	GEEN X PARTICIPLE
ballon varen	niet ballon gevaren: 7	geen ballon gevaren: 1
parachute springen	niet parachute gesprongen: 13	geen parachute gesprongen: 9
stelt lopen	niet stelt gelopen: 0	geen stelt gelopen: 0
wad lopen	niet wad gelopen: 7	geen wad gelopen: 5

## D. Conclusion

What we have seen in the previous subsections is that the collocations in (66) exhibit a rather mixed behavior. The results in Table (67) clearly show that they do not count as compounds when it comes to participle formation. However, the results in Table (68) concerning the formation of *te*-infinitivals are more equivocal with regard to compound status. It seems nevertheless safe to conclude that we are not dealing with true compounds and this may explain that the collocations cannot undergo verb-second as a whole. Tables (69)-(71) show that the collocations tend to behave as word-like V\*-units ( $[_{V^*} X V^{\circ}]$ ), as shown by the second column of these tables; this could be the reason why these collocations tend not to undergo verb-second. However, some of the more frequently used forms like *parachute springen* and (to a lesser extent) *wad lopen* occasionally exhibit a more phrasal structure  $[_{V'} X V^{\circ}]$  behavior, as evidenced by the third columns in (69) to (71). This may perhaps be held responsible for the fact that verb-second is possible under more restricted circumstances. What remains mysterious from a theoretical point of view is that the collocations of the type *touwtje springen* 'to skip' cannot be analyzed as compounds: Subsection V has shown that the X-part normally functions as a complement of the verbal part in structures like  $[_{V'} X V^{\circ}]$  and  $[_{V^*} X V^{\circ}]$ , while the nominal part of the type *touwtje springen* rather receives an adverbial interpretation.



VII. *Immobile verbal collocations (4): type stijl dansen ‘to ballroom dance’*

This subsection discusses collocations like *stijl dansen*, which differ from the collocations discussed in the previous sections in that the N-part can remain adjacent to the verbal part in the corresponding past/passive participial form. We will investigate forms that satisfy the following three criteria: (i) the N-part of the collocation normally remains left-adjacent to the verbal part in past/passive participial forms (*ge-X-V-d/t*), (ii) the N-part cannot be interpreted as the theme argument of the verbal part, and (iii) the Van Dale dictionary states that the collocation occurs in its infinitival form only.

There are in fact not many collocations that satisfy these criteria. Booij (2010: 112) provides eight potential cases (only three of which can also be found in the list found at *Taaladvies.net*). We omitted *steengrillen* ‘stone grilling’ as it does not satisfy criterion (iii). We also omitted *buikspreken* ‘to ventriloquize’ and *masklimmen* ‘to pole climb’, because for these verbs we did not find any cases that satisfied criterion (i); *gebuikspreekt* was only used in discussions on the correct form of the past participle and *gemasklimd* did not occur at all. This leaves us with the four forms in (72) besides *stijl dansen* (although it is certainly possible to find more cases like, e.g., *mond schilderen* ‘to paint with the mouth’, *windsurfen* ‘to be windsurfing’ and *watertrappelen* ‘to tread water’).

- |         |                                 |    |                      |
|---------|---------------------------------|----|----------------------|
| (72) a. | koord dansen                    | c. | zak lopen            |
|         | rope dance                      |    | sack walk            |
|         | ‘to walk a tight rope/high wire |    | ‘to run a sack race’ |
| b.      | vinger verven                   | d. | zee zeilen           |
|         | finger paint                    |    | sea sail             |
|         | ‘to finger-paint’               |    | ‘to sail the ocean’  |

Note in passing that it is not clear whether *stijl dansen* itself satisfies criterion (ii) given that examples such as *Kaylah danst voornamelijk de Egyptische stijl* ‘Kaylah mainly dances the Egyptian style’ are quite frequent on the internet. Although we consider this use marked, it might indicate that we are actually dealing with a collocation in which the N-part is a theme argument of the verbal part; see Subsection VIII. We will not elaborate on this issue here.

A. *Past/passive participles and te-infinitives*

Let us first look at the past/passive participle form of the collocations in (72). For each collocation a search was made for two forms: X + *ge-V-d/t* and *ge-X-V-d/t*. We spelled the first form without a space in order to exclude cases in which X is part of some preverbal constituent; this may have resulted in a lower number of hits for the form X + *ge-V-d/t* than we would have had if we had also searched for cases with a space. Duplicates or irrelevant cases were not weeded out but we did check whether the desired construction was included. The results in Table (73) show us that three of the four collocations tend to be treated like true compounds (especially since many of the hits in the second column must be dismissed as irrelevant for various reasons). It seems likely that *zaklopen* should be dismissed from this set: if we take into account that many more cases can be found if we include cases with a space between the N-part *zak* and the V-part *gelopen*, the collocation seems rather

to belong to the type *touwtje springen* discussed in the previous subsection than to the type under discussion here.

(73) Past/passive participle forms

	X + GE-V-D/T	GE-X-V-D/T
koord dansen	koord gedanst: 12	gekoorddanst: 37
vinger verven	vinger geverfd: 18	gevingerverfd: 216
zaklopen	zak gelopen: 103	gezakloopt: 22
zeezeilen	zee gezeild: 6	gezeezeild: 17

The overall picture that emerges from Table (73) seems to be confirmed by the results of our Google searches on *te*-infinitival forms in Table (74), although again there are cases in which the collocations are split.

(74) *Om + te* forms

	OM X TE V	OM TE X V
koord dansen	om koord te dansen: 11	om te koord dansen: 29
vinger verven	om vinger te verven: 0	om te vinger verven: 33
zaklopen	om zak te lopen: 13	om te zak lopen: 19
zeezeilen	om zee te zeilen: 0	om te zee zeilen: 27

B. *Progressive aan het + V<sub>infinitive</sub> constructions, verb clusters and negation*

The tendency to construe the collocations as compounds makes it very likely for them to exhibit the behavior of a syntactic unit. This is fully confirmed by the results in Table (75). A manual check of the results for the string [*X aan het V*] showed that there is not a single case in which the collocations are split in the progressive *aan het + V<sub>infinitive</sub>* constructions. Given this result, we did not bother to apply the verb clustering and the negation test.

(75) Progressive *aan het + V<sub>infinitive</sub>* phrases

	AAN HET X V	X AAN HET V
koord dansen	aan het koorddansen: 85	koord aan het dansen: 0
vinger verven	aan het vingerverven: 90	vinger aan het verven: 0
zaklopen	aan het zaklopen: 69	zak aan het lopen: 0
zeezeilen	aan het zeezeilen: 23	zee aan het zeilen: 0

C. *Conclusion*

Given the discussion in the previous subsections, it will not be surprising that in the relatively rare cases of verb-second the collocations in (72) will be treated as true compounds. Whereas it is fairly easy to find verb-second of the full collocation, we did not succeed in finding cases of the split pattern in sentences with third person singular simple present verb forms. This was checked manually after filtering out several frequently occurring substrings in the results, e.g., by means of the Google search *[[zeit \* zee] AND [-op zee]]*, which results in potentially split verb-second constructions without the adverbial phrase *op zee* ‘at sea’.

The fact that the collocations in (72) can be treated as regular compounds does raise a question, however: why do these verbs tend to not undergo verb-second at all. The answer to this problem seems to be related to the fact that speakers are somewhat uncertain about the compound analysis of the collocations in question, as is clear from the results in Tables (73) and (74). This may result in a tendency to avoid verb-second in favor of constructions involving the progressive *aan het* +  $V_{\text{infinitive}}$  construction. If correct, this suggests that we are dealing with a performance restriction, which unfortunately would imply that no further light can be shed on this issue from a syntactic point of view.

### VIII. Immobile verbal collocations (5): *type gedachtelezen* ‘to mind-read’

This subsection discusses collocations like *gedachte lezen* ‘to mind-read’, which differ from the collocations in the previous subsections in that the N-part does function as a theme of the V-part. There need be no *a priori* expectations concerning the question as to whether such collocations are compounds ( $[_V X V]$ ), syntactically derived  $V^*$ -units ( $[_V X V^*]$ ), or phrasal structures ( $[_V X V^0]$ ). We therefore simply selected cases from the earlier-mentioned list of N+V collocations found at [taaladvies.net/taal/advies/vraag/703](http://taaladvies.net/taal/advies/vraag/703) satisfying the van Dale dictionary criterion that they occur in their infinitival form only. We included one clearly idiomatic case, *lijn trekken* ‘to slack off/to malinge’, and one case in which the N-part corresponds to the nominal part of a PP-complement, *spoor zoeken* ‘to trace’; cf. *zoeken naar sporen* ‘to search for traces’.

- |         |   |    |  |
|---------|---|----|--|
| (76) a. | hand lezen<br>hand read<br>‘to palm read’   | c. | lijn trekken<br>line draw<br>‘to malinge’  |
| b.      | kogel stoten<br>ball shoot<br>‘to shot-put’ | d. | spoor zoeken<br>trace search<br>‘to track’ |

#### A. Past/passive participles and te-infinitives

For each collocation we looked for two participial forms:  $X + ge\text{-}V\text{-}d/t$  and  $ge\text{-}X\text{-}V\text{-}d/t$ . We spelled the forms without a space in order to exclude cases in which X is part of some preverbal constituent; this resulted in a lower number of cases of the form  $X + ge\text{-}V\text{-}d/t$  than we would have harvested if we had also searched for cases with a space. The results in (77) were checked manually and the numbers refer to attested cases of the looked-for construction.

#### (77) Past/passive participle forms

	$X + ge\text{-}V\text{-}D/T$	$ge\text{-}X\text{-}V\text{-}D/T$
hand lezen	hand gelezen: 9	gehandleesd: 0
kogel stoten	kogel gestoten: 26	gekogelstoot: 18
lijn trekken	lijn getrokken: 10	gelijntrekt: 0
spoor zoeken	spoor gezocht: 10	gespoorzoekt: 3

Table (78) shows the results for our Google searches for the strings [*om X te V*] and [*om te X V*], the latter with and without a space between X and V. The results were checked manually and the numbers again refer to attested cases of the intended construction.

(78) *Om + te* forms

	<i>OM X TE V</i>	<i>OM TE X V</i>
hand lezen	om hand te lezen: 4	om te hand lezen: 5
kogel stoten	om kogel te stoten: 13	om te kogel stoten: 37
lijn trekken	om lijn te trekken: 9	om te lijntrekken: 2
spoor zoeken	om spoor te zoeken: 13	om te spoorzoeken: 15

The results in Tables (77) and (78) are ambivalent: whereas (77) suggests that speakers seem to disfavor a compound analysis for the collocations in (76), we cannot draw such a conclusion from (78).

B. *Progressive aan het + V<sub>infinitive</sub> constructions, verb clusters and negation*

The results in Table (79) suggest that a phrasal analysis is excluded; given the large number of irrelevant hits for the string [*aan het X-V*], we stopped counting after we found 10 instantiations of the construction we were looking for.

(79) *Progressive aan het + V<sub>infinitive</sub> phrases*

	<i>AAN HET X V</i>	<i>X AAN HET V</i>
hand lezen	aan het handlezen: 6	hand aan het lezen: 3
kogel stoten	aan het kogelstoten: > 10	kogel aan het stoten: 1
lijn trekken	aan het lijntrekken: > 10	lijn aan het trekken: 0
spoor zoeken	aan het spoorzoeken: > 10	spoor aan het zoeken: 0

That the phrasal analysis is at best marginally available seems to be confirmed by the results of the verb-clustering test. Given the results in (79), we applied this test only to the collocations *hand lezen* and *kogel stoten*. The string [*hand kan lezen*] resulted in 4 instantiations and the string [*kogel kan stoten*] in just one instantiation of the construction. This contrasts sharply with the strings [*kan handlezen*] and [*kan kogelstoten*], which resulted in many relevant hits. The search strings [*geen hand \* kan lezen*] and [*geen kogel kan stoten*] resulted in just one relevant case for *hand lezen*.

C. *Conclusion*

The previous subsections show that the collocations in (76) are preferably analyzed as V\*-units and consequently correctly predict that verb-second is strongly disfavored. The results in the third column of Table (79) show first of all that these collocations cannot readily be analyzed as phrasal ([*V' X V°*]), so that the split pattern does not easily appear either. The results in Table (77) show that they cannot readily be analyzed as compounds ([*V° X V*]), so that they cannot undergo verb-second as a whole either. As was also observed for collocations like *touwtje springen*, discussed in Subsection IV, it seems that the results in Table (78) are

problematical for this account of the immobility of collocations like *hand lezen* because they suggest that a compound analysis is also possible.

*IX. Immobile verbal collocations (6): particle verbs (vooraanmelden ‘to preregister’)*

This section discusses a type of X+V collocation that has probably received most attention in the linguistic literature, namely particle verbs. Particle verbs are verbs preceded by a preposition-like element, that is, P+V collocations. Such collocations are like other types of X+V collocation in that there are various subtypes when it comes to verb-second: there are collocations that undergo verb-second as a whole, collocations that are split under verb-second, and collocations that resist verb-second in any form.

- (80) a. dat Jan de mogelijkheden overweegt. [inseparable P+V collocation]  
 that Jan the possibilities considers  
 ‘that Jan is considering the possibilities.’  
 a’. Jan overweegt de mogelijkheden.  
 Jan considers the possibilities  
 b. dat Marie zich voor het examen aanmeldt. [separable P+V collocation]  
 that Marie REFL for the exam prt.-registers  
 ‘that Marie registers for the exam.’  
 b’. Marie meldt zich voor het examen aan.  
 Marie registers REFL for the exam prt.  
 c. dat Marie zich voor het examen vooraanmeldt. [immobile P+V collocation]  
 that Marie REFL for the exam pre-prt.-registers  
 ‘that Marie preregisters for the exam.’  
 c’. \*Marie vooraanmeldt zich voor het examen.  
 Marie pre.-prt.-registers REFL for the exam  
 c’’. \*Marie meldt zich voor het examen vooraan.  
 Marie registers REFL for the exam prt.-prt.

Inseparable and separable P+V collocations differ as to the placement of word stress. Inseparable collocations are normally considered compounds, and are characterized by the fact that they have main stress on the second member: the P+V collocation in (80a) is pronounced as *overWEgen*, not as *Overwegen*. Separable collocations, on the other hand, exhibit a stress pattern that is typical of verb phrases consisting of a verb and a complementive, that is, they have stress on the preverbal element: the P+V collocation in (80b) is pronounced as *AAN melden*, not as *aan MELden*. The examples in (81) illustrate this again for the ambiguous verb *voorkomen*, and we refer to Section P1.2.4.4 for a more detailed comparison of the two types of P+V collocations. In what follows we will follow the general practice of restricting the term particle verb to separable (and immobile) P+V collocations.

- (81) a. dat het gebruik van een helm serieuze ongelukken voorkOMT. [compound]  
 that the use of a helmet grave accidents prevents  
 ‘that the use of a helmet will prevent grave accidents.’  
 a’. Het gebruik van een helm voorkomt serieuze ongelukken.  
 the use of a helmet prevents grave accidents

- b. dat dit soort serieuze ongelukken vaak voorkomt. [particle verb]  
 that this type [of] grave accidents often prt.-occurs  
 ‘that this type of grave accidents occurs often.’
- b’. Dit soort serieuze ongelukken komt vaak voor.  
 this type [of] grave accidents occurs often prt.

A typical property of immobile particle verbs like *voor aan melden* ‘to preregister’ in (80c) is that there are two independent particles involved, that is, that we are dealing with the structure [*voor [aan melden]*]. That the two particles are independent of each other is crucial in view of the fact that a particle verb like *vooraan plaatsen* ‘to place in front’, in which *vooraan* is a complex preposition, counts as a regular, separable particle verb with the structure [[*voor+aan*]/*plaatsen*]: *We plaatsen de kinderen vooraan* ‘we place the children in front’. The two cases can again be distinguished by their stress pattern: the complex preposition has stress on the second member (*voorAAN plaatsen*), whereas in the double particle case main stress is on the first particle (*VOOR aan melden*).

There are in fact not many double particle verbs like *voor aan melden*. This is to be expected as verbal particles generally have the syntactic function of °complementive, and clauses cannot normally have more than one complementive; cf. Section 2.2. The collocation *voor aan melden* is the example normally used as an illustration in the linguistic literature, but in (82) we provide a number of other cases that can be found in the Van Dale dictionary or on the internet. Note that we have not been able to find any cases in which a verbal particle forms a collocation with a P+V compound; we did find *vooronderstellen* ‘to presuppose’ but this complex form behaves as a compound itself.

- (82) a. *onder aan besteden* ‘to assign a commission to a subcontractor’  
 b. *onder aan nemen* ‘to accept a commission as a subcontractor’  
 c. *voor aan melden* ‘to preregister’  
 d. *voor af beelden/spiegelen* ‘to foretell in metaphorical form’  
 e. *voor in schrijven* ‘to preregister/presubscribe’  
 f. *voor in tekenen* ‘to presubscribe’

Immobile particle verbs also arise when a separable particle verb like *aanmelden* ‘to register’ in (80b) is prefixed with the prefix *her-* ‘re-’. Prefixation with *her-* of inseparable P+V compounds like *overwegen* ‘to consider’ in (80a), on the other hand, does not affect the verb-second property; the prefixed form will undergo verb-second as a whole. This is illustrated in (83).

- (83) a. dat Jan de mogelijkheden heroverweegt. [inseparable compound verb]  
 that Jan the possibilities reconsiders  
 ‘that Jan is reconsidering the possibilities.’
- a’. Jan heroverweegt de mogelijkheden.  
 Jan reconsiders the possibilities

- b. dat Marie zich voor het examen heraanmeldt. [immobile particle verb]  
 that Marie REFL for the exam re-prt.-registers  
 'that Marie is reregistering for the exam.'
- b'. \*Marie heraanmeldt zich voor het examen.  
 Marie re-prt.-registers REFL for the exam
- b''. \*Marie meldt zich voor het examen heraan.  
 Marie registers REFL for the exam re-prt.

In (84), we provide some examples of P+V compounds and particle verbs prefixed with *her-*, taken from the Van Dale dictionary; as P+V compounds are relatively rare, it need not surprise us that inseparable cases such as (84a) are heavily outnumbered by immobile cases such as (84b).

- (84) a. Inseparable: *heronderzoeken* 'to reinvestigate', *heroverwegen* 'to reconsider'  
 b. Immobile: *heraanbesteden* 'to contract out again', *heraanstellen* 'to re-appoint', *herindelen* 'to reclassify', *herindijken* 'to re-embank', *herinvoeren* 'to reintroduce', *heropbouwen* 'to rebuild', *heropleven* 'to revive anew', *heropnemen* 'to restart', *heroprichten* 'to re-establish', *heropvoeden* 'to re-educate', *heropvoeren* 'to perform again', *heruitrusten* 'to re-equip'

The previous subsections have shown that many immobile N+V collocations exhibit properties that we have attributed to syntactically derived or lexically listed V\*-units ([<sub>V\*</sub> X V<sup>o</sup>]). From a theoretical point of view, a similar analysis seems possible for particle verbs since verbal particles are often analyzed syntactically as predicative complements of the verb (i.e., complementives) and are thus expected to be able to undergo incorporation; we refer the reader to Subsections I and V for further discussion. Recall from our discussion above example (82) that we have not been able to find any cases in which a P+V compound is combined with a verbal particle, which explains the empty cell in this table.

(85) P+V collocations (plus verbal particle or prefix *her-*)

	COMPOUND	PARTICLE VERB
P+V COLLOCATION	<i>overwegen</i>	<i>aanmelden</i>
DOUBLE PARTICLE VERB	—	<i>vooraanmelden</i>
PREFIXED WITH HER-	<i>heroverwegen</i>	<i>heraanmelden</i>

In the remainder of this subsection we will investigate from this perspective the double particle verb and the prefixed P+V collocation from Table (85). We will follow the list of relevant properties in Table 4; the expression of sentence negation is of course irrelevant given that it applies specifically to N+V collocations.

#### A. The formation of past/passive participles

P+V compounds like *overwegen* are somewhat special in that they do not get the regular participial °circumfix *ge-...-d/t*. The preverbal part *ge-* is obligatorily truncated, which results in the (irregular) form *overwogen* in (86a) instead of the expected form \**geoverwogen*; as is expected for a compound, \**overgewogen* is also impossible. Example (86b) shows that separable particle verbs like *aanmelden* do



get the preverbal *ge-* part of the regular circumfix and that, as expected for a separable X+V collocation, the verbal particle must precede it: \**geaanmeld*.

- (86) a. Jan heeft de mogelijkheden overwogen.  
 Jan has the possibilities considered  
 'Jan has considered the possibilities.'  
 b. Jan heeft zich aangemeld.  
 Jan has REFL prt.-registered  
 'Jan has registered.'

The examples in (87) show that double particle verbs essentially behave like regular particle verbs: the full circumfix *ge-...-d/t* is used and the *ge-* part must be adjacent to the verbal part of the collocation, that is, it is obligatory and placing it in front of the first or the second particle results in unacceptability. This is also clear from our Google searches; the past/passive participles *vooraangemeld* and *vooringetekend* occur frequently (> 100 hits) on the internet, whereas the forms \**gevooraanmeld*, \**voorgeaanmeld*, \**gevoorintekend* and \**voorgeintekend* are not found at all. Note in passing that we placed the simplex reflexive in (87b) between parentheses because constructions like these can be found on the internet both with and without it, that is, some but not all speakers make the collocation inherently reflexive.

- (87) a. Jan heeft zich vooraangemeld.  
 Jan has REFL prt.-prt.-registered  
 'Jan has preregistered.'  
 b. Jan heeft (zich) vooringetekend voor het boek.  
 Jan has REFL prt-subscribed to the book  
 'Jan presubscribed to the book.'

The examples in (88) show that the use of *her-* leaves the properties of the input unaffected: *heroverwegen* behaves like *overwegen* in that it does not allow the preverbal *ge-* part of the participial circumfix, and *heraanmelden* behaves like *aanmelden* in that the *ge-* part is obligatory and must be adjacent to the verb.

- (88) a. Jan heeft zijn beslissing heroverwogen.  
 Jan has his decision re-considered  
 'Jan has reconsidered his decision.'  
 b. Jan heeft zich heraanmeld.  
 Jan has REFL re-prt.-registered  
 'Jan has reregistered.'

It should be pointed out that it has been claimed for certain particle verbs that the form prefixed with *her-* has a certain flexibility in its participial form. One case is *heropvoeden*. Bennis (1993) notes that his informants accept the first three forms in (89); the only form rejected categorically is the one in (89d). We tested this by means of a Google search on each form; duplicates or irrelevant cases were not filtered out from the results, but we did check whether the intended construction was included. We use the indication <201 in (89a) because the form *heropvoed* is frequently used as a finite, first person singular form, as a result of which the precise number of participial uses could not be determined. The em-dash in (89d)



indicates that a cursory look immediately revealed that all cases of *hergeopvoed* were of dubious origin. We also searched for the following strings: [*heeft \* V*], [*heeft V*] and [*V heeft*] in order to get an impression of the use of the strings as past participles; as the numbers were generally low, we checked the results manually. We stopped counting the past participle *hergeopvoed* after we had found 20 occurrences (which happened after we checked the first 30 of 60 hits in total).

- |         |             |                    |                        |
|---------|-------------|--------------------|------------------------|
| (89) a. | heropvoed   | [participle: <201] | [past participle: 3]   |
| b.      | geheropvoed | [participle: 39]   | [past participle: 0]   |
| c.      | heropgevoed | [participle: 486]  | [past participle: >20] |
| d.      | hergeopvoed | [participle: —]    | [past participle: 0]   |

The results in (89) suggest that some speakers may indeed feel that *heropvoeden* is a compound verb. It is doubtful, however, whether this can be generalized to other cases such as *heraanmelden*: whereas a search for *heraangemeld* resulted in 70 hits, there were only two relevant cases with *geheraanmeld* and none with *heraanmeld*.

### B. The formation of te-infinitives

The examples in (90) show that the compound verb *overwegen* cannot be split, whereas the particle verb *aan melden* must be split in certain contexts. Note again that the orders marked with a star can be found on the internet, but since the numbers are small and the results sound extremely bizarre, we have decided to simply ignore them.

- |         |              |                   |   |
|---------|--------------|-------------------|---|
| (90) a. | Jan zit      | de mogelijkheden  | te overwegen/*over te wegen.            |
|         | Jan sits     | the possibilities | to consider                             |
|         |              |                   | ‘Jan is considering the possibilities.’ |
| b.      | Jan probeert | zich aan          | te melden/*te aanmelden.                |
|         | Jan tries    | REFL prt.         | to register                             |
|         |              |                   | ‘Jan is trying to register.’            |

Our Google search on the string [*vooraan te melden*] resulted in 28 hits, only three of which involved the construction aimed at. However, the results for the string [*voor aan te melden*] (with a space between the two particles) include an uncertain number of relevant cases: in the majority of the results, *voor* seems to function as the prepositional part of a pronominal PP (e.g. *Hij probeert zich hier tijdig voor aan te melden* ‘He is trying to register for this in time’), but we managed to find a small number of cases of the intended construction while browsing through the first 100 results. Since the string [*te vooraan melden*] resulted in just one relevant case, it seems safe to conclude that *voor aan melden* behaves as a (separable) particle verb. The string [*voor in te tekenen*] resulted in 60 hits, but not all hits involved the construction looked for; we stopped our manual count after we found 20 relevant cases; the string [*voorin te tekenen*] resulted in four more relevant hits. Our search on [*te voorintekenen*], with various placements of extra spaces, resulted in just two hits, so that we can again conclude that we are dealing with a (separable) particle verb.

- (91) a. Jan heeft besloten zich voor aan te melden.  
 Jans has decided REFL pre prt. to register  
 ‘Jan has decided to preregister.’
- b. Jan heeft besloten (zich) voor in te tekenen voor het boek.  
 Jans has decided REFL pre prt. to subscribe to the book  
 ‘Jan has decided to presubscribe to the book.’

The results of our Google searches for similar examples with *her-* are far from unequivocal. The numbers in square brackets in (92) are the combined results of searches for various variants of the strings [*te her-P-V*] and [*her-P te V*], e.g., with or without a space between *her* and the P-element. Naturally, the results for the (a)-examples are in line with our earlier conclusion that the use of *her-* does not affect the separability of the input collocation, but the results for the (b)-examples are surprising in that they show that *heraanmelden* sometimes behaves like a compound.

- (92) a. Jan heeft besloten zijn beslissing te heroverwegen. [494]  
 Jan has decided his decision to reconsider  
 ‘Jan decided to reconsider his decision.’
- a'. \*Jan heeft besloten zijn beslissing herover te wegen. [2]
- b. Jan heeft besloten zich te heraanmelden. [5]  
 Jan has decided REFL to re-prt-register  
 ‘Jan has decided to reregister.’
- b'. Jan heeft besloten zich heraan te melden. [9]

For completeness' sake, (93) shows that the result is even more spectacular in the case of *heropvoeden*: (89) has shown that it is sometimes treated as a compound in the case of participle formation. The results of our Google searches show that in the majority of *te*-infinitives this collocation is treated as a compound.

- (93) a. te heropvoeden [511]  
 to re-prt.-educate  
 ‘to re-educate’
- b. herop te voeden [314]
- c. her te opvoeden [4]

### C. Word order in progressive aan het + *V*<sub>infinitive</sub> constructions

Our Google searches on progressive constructions like [*vooraan aan het melden*] and [*aan het vooraanmelden*], with various placements of extra spaces, did not result in any cases of the construction we are investigating, and we therefore simply provide our own judgments in (94). Examples such as (94a) are also discussed in Blom (2005), who assigns them a question mark. Unfortunately, she does not discuss the order in (94b), which to our ears sounds far more degraded. Blom also notes that separating the two particles, as in (94c), is impossible.

- (94) a. dat Jan zich aan het VOOR aan melden is.  
 that Jan REFL AAN HET pre prt. register is  
 ‘that Jan is preregistering.’
- b. ??dat Jan zich VOORaan aan het melden is.
- c. \*dat Jan zich VOOR aan het aanmelden is.

For completeness' sake, note that (94b) is fully acceptable if *vooraan* is construed as an adverbial phrase of place, which requires the compound stress pattern *voorAAN*. In (94c), *voor* can readily be interpreted as a locational adverbial phrase. This is, of course, irrelevant to our present discussion.

Example (95) contains similar cases with *voorintekenen*. Since we were not able to find any relevant cases on the internet, our own judgments must suffice. Although (95a) may be considered somewhat marked by some speakers, it sharply contrasts with (95b&c), which seem severely degraded. Example (95c) is again acceptable with the irrelevant adverbial reading of *voor*.

- (95) a. dat Jan (zich) aan het voor in tekenen is.  
           that Jan REFL AAN HET pre prt. subscribe is  
           ‘that Jan is presubscribing.’  
       b. ??dat Jan (zich) VOORin aan het tekenen is.  
       c. \*dat Jan (zich) voor aan het intekenen is.

We now proceed to similar examples for cases with *her-*. Example (96) shows first that *heroverwegen*, in accordance with our findings above that it exhibits compound behavior, cannot be split; cases like (96b&c) do not occur on the internet.

- (96) a. Jan is zijn beslissing aan het heroverwegen.  
           Jan is his decision AAN HET reconsider  
           ‘Jan is reconsidering his decision.’  
       b. \*Jan is zijn beslissing herover aan het wegen.  
       c. \*Jan is zijn beslissing her aan het overwegen.

Although verbs like *heraanmelden* can be optionally split by the infinitival marker *te*, our judgments on the examples in (97) indicate that the split is not possible in the progressive *aan het* +  $V_{\text{infinitive}}$  construction.

- (97) a. Jan is zich aan het heraanmelden.  
           Jan is REFL AAN HET re-prt.-register  
           ‘Jan is reregistering’  
       b. \*Jan is zich her aan aan het melden.  
       c. \*Jan is zich her aan het aanmelden.

Although there are no relevant cases of *heraanmelden* on the internet, our judgments seem to be confirmed by similar Google searches for the verbs *herindelen* ‘to reclassify’, *herinvoeren* ‘to reintroduce’, *heropbouwen* ‘to rebuild’, and *heropvoeden* ‘to re-educate’: all these verbs frequently occur in the string [aan het *her* + *particle* +  $V_{\text{infinitive}}$ ] but virtually never in the string [*her* + *particle* + *aan het* +  $V_{\text{infinitive}}$ ]. The conclusion we can draw from the discussion above is that verbs like *vooraanmelden* and *heraanmelden* cannot be analyzed as phrasal ( $[_V X V^0]$ ), but must be seen as word-like  $V^*$ -units ( $[_V^* X V^0]$ ); see Table 4.

#### D. Word order in verb cluster constructions

Our judgments on the word order in the verb clusters in (98) lead to the same conclusion as in the previous subsection. The search strings [*moet vooraanmelden*] and [*kan voorinschrijven*] in the primeless examples can be found on the internet,

albeit scantily sometimes; our Google searches resulted in 2 relevant hits for the former and 10 for the latter. We were not able to find any instances of the orders in the primed examples. It stands to reason that we have ignored cases in which the P-elements were used with an adverbial meaning or where they were part of a split pronominal PP.

- (98) a. Zoek uit of je je moet vooraanmelden via Blackboard.  
 find out whether you REFL must pre-prt.-register via Blackboard  
 ‘Find out whether you have to preregister via Blackboard.’  
 a'. \*<sup>?</sup>Zoek uit of je je vooraan moet melden via Blackboard.  
 a''. \*Zoek uit of je je voor moet aanmelden via Blackboard.  
 b. Ik lees net dat ik niet meer kan voorinschrijven.  
 I read just that I no longer can pre-prt-subscribe  
 ‘I’m just reading here that I can no longer preregister.’  
 b'. \*<sup>?</sup>Ik lees net dat ik niet meer voorin kan schrijven.  
 b''. \*Ik lees net dat ik niet meer voor kan inschrijven.

Our judgments on the examples in (99) again lead to the same conclusion. The search strings [*moet heraanmelden*] and [*moet voorinschrijven*] in the primeless examples are easy to find on the internet; our Google searches resulted in 3 relevant hits for the former and 46 for the latter. We were not able to find any instances of the orders in the primed examples.

- (99) a. dat je je bij het opstarten moet heraanmelden.  
 that one REFL with the booting must re-prt.-register  
 ‘During booting one has to reregister.’  
 a'. \*dat je je bij het opstarten her aan moet melden.  
 that one REFL with the booting re- prt must register  
 b. Ik weet niet goed hoe ik mij moet herinschrijven.  
 I know not well how I REFL must re-prt.-write  
 ‘I’m not certain how to reregister.’  
 b'. Ik weet niet goed hoe ik mij her in moet schrijven.  
 I know not well how I REFL re- prt. must write

### E. Conclusion

The discussion above has shown that double particle verbs like *voor aan melden* ‘preregister’ and particle verbs prefixed with *her-* behave like V\*-units; they can be separated when the formation of past/passive participles or *te*-infinitives is involved, but not in progressive *aan het* + V<sub>infinitive</sub> or verb-cluster constructions. The fact that they resist verb-second is therefore expected; see Table 4.

### X. Immobile verbal collocations (7): type voorverkopen ‘to sell in advance’

This subsection concludes with a brief discussion of a type of immobile verb that has received relatively little attention in the literature so far; see Den Dikken (2003) for some preliminary remarks. Consider the examples in (100), in which a verb prefixed with *ver-* is preceded by some particle-like element.

- (100) a. dat Jan de oven voorverwarmt. [separable]  
 that Jan the oven prt-ver-heats  
 ‘that Jan is preheating the oven.’  
 a’. Jan verwarmt de oven voor.  
 b. dat Jan de motor oververhit. [inseparable/compound]  
 that Jan the engine prt.-ver-heats  
 ‘that Jan is overheating the engine.’  
 b’. Jan oververhit de motor.  
 c. dat Jan de kaartjes voorverkoopt. [immobile]  
 that Jan the tickets prt.-ver-sells  
 ‘that Jan is selling the tickets in advance.’  
 c’. \*Jan voorverkoopt de kaartjes.  
 c’’. \*Jan verkoopt de kaartjes voor.

The (a)-examples behave more or less as expected given that particle verbs are normally separable, so nothing much needs to be said about these cases. The (b)-examples are also as expected since *over* with the meaning component “too much” normally behaves as a prefix and is thus expected to be pied-piped under verb-second; cf. *Jan overvoedt zijn kat* ‘Jan is giving his cat too much food’. The (c)-examples are the unexpected, immobile cases, which allow neither °pied piping nor °stranding, and simply resist verb-second altogether.

Since verbs prefixed with *ver-* block the realization of the preverbal part of the participial circumfix *ge-...-d/t*, we can only determine whether or not the P+V collocations are compounds by investigating the *te*-infinitives in (101). As expected, the inseparable P+V collocation in the (b)-examples must appear as a unit after the inflectional element *te*, whereas the two other collocation types cannot; although some speakers may feel uncomfortable with example (101c), they will agree that it is much better than its primed counterpart.

- (101) a. Jan belooft de oven voor te verwarmen. [separable]  
 Jan promises the over prt. to ver-heat  
 ‘Jan promises to preheat the oven.’  
 a’. \*Jan belooft de oven te voorverwarmen.  
 b. Jan belooft de motor niet te oververhitten. [inseparable/compound]  
 Jan promises the engine not to over-ver-heat  
 ‘Jan promises not to overheat the engine.’  
 b’. \*Jan belooft de motor niet over te verhitten.  
 c. ?Jan probeert de kaartjes voor te verkopen. [immobile]  
 Jan tries the tickets prt to sell  
 ‘Jan is trying to sell the tickets in advance.’  
 c’. \*Jan probeert de kaartjes te voorverkopen.

We expect the separable collocation *voor verwarmen* to differ from the immobile collocation *voor verkopen* in that only the former can be split in the progressive *aan het* + V<sub>infinitive</sub> constructions. Our judgments given in (102) indicate that this is indeed borne out. These judgments seem to be confirmed by a Google search (11/2/2015): the split form [*voor aan het verwarmen*] indeed occurs on the internet a couple of times while the string [*voor aan het verkopen*] could not be found.

- (102) a. Jan is de oven <<sup>(?)</sup>voor> aan het <voor> verwarmen. [separable]  
 Jan is the oven prt. AAN HET heat  
 'Jan is preheating the oven.'
- b. Jan is de kaartjes <<sup>\*\*?</sup>voor> aan het <voor> verkopen. [immobile]  
 Jan is the tickets prt. AAN HET sell  
 'Jan is selling the tickets in advance.'

For completeness' sake, we also provide our judgments on the verb-clustering constructions. Unfortunately, we were not able to find support for our judgments by unequivocal internet data given that there was too much interfering data. Again [*voor zal verwarmen*] does occur on the internet, while the search for [*voor zal verkopen*] did not result in any relevant case.

- (103) a. dat Jan de oven <<sup>(?)</sup>voor> zal <voor> verwarmen. [separable]  
 that Jan the oven prt. will heat  
 'that Jan will preheat the oven.'
- b. dat Jan de kaartjes <<sup>??</sup>voor> zal <voor> verkopen. [immobile]  
 that Jan the tickets prt. will sell  
 'that Jan will be selling the tickets in advance.'

The data discussed in this subsection confirm our expectation that the immobile P+V collocation *voorverkopen* is a V\*-unit. Many questions remain, however, such as what determines whether we are dealing with a separable or an inseparable collocation. We will leave this for future research.

### XI. Summary

This section has discussed various verb types that resist verb-second in main clauses. Verb-second resistance was found in certain X+V collocations like *touwtje springen* 'to skip', in double particle verbs like *voor aan melden* 'to preregister', and in particle verbs preceded by the prefix *her-* like *heraanmelden* 'to reregister'. In order to provide sufficient background information for the discussion of these so-called immobile verbs, Subsections I-III provided evidence that there are at least three types of X+V collocations with the distinguishing properties indicated in Table 5. The first type, [<sub>V</sub> X V<sup>o</sup>], is made up of true compounds; the constituent parts X and V cannot be targeted individually by the morphological and syntactic processes indicated in the rows A to C. The second type, [<sub>V'</sub> X V<sup>o</sup>], consists of phrasal constituents; the constituent parts X and V can be targeted individually by the morphological and syntactic processes indicated in the rows A to C. The third type, [<sub>V\*</sub> X V<sup>o</sup>], is a kind of in-between category; the constituent parts of the V\*-unit can be targeted individually by the morphological processes in the A-row but not by the syntactic processes in the B-row. Moreover, V\*-units are special in that they are immobile; verb-second can neither affect the verbal part in isolation nor the collocation as a whole.

Table 5: *Types of verbal collocations*

		[ <sub>v*</sub> X V]	[ <sub>v'</sub> X V°]	[ <sub>v*</sub> X V°]
A	PARTICIPIAL AFFIX	<i>ge-X+V-d/t</i>	X <i>ge-V-d/t</i>	X <i>ge-V-d/t</i>
	INFINITIVAL PREFIX	<i>te X+V</i>	X <i>te V</i>	X <i>te V</i>
B	VERBAL CLUSTERS	V X V <sub>main</sub>	X V V <sub>main</sub>	V X V <sub>main</sub>
	AAN HET-PHRASE	<i>aan het X V<sub>main</sub></i>	X <i>aan het V<sub>main</sub></i>	<i>aan het X V<sub>main</sub></i>
	NEGATION	<i>niet</i> 'not'	<i>geen</i> 'no'	<i>niet</i> 'not'
C	VERB-SECOND	+ (non-split pattern)	+ (split pattern)	—

The immobile V\*-units seem to fall apart in at least two subtypes. First, Subsection IV has shown that (optional) syntactic incorporation into the verb of (i) a bare nominal object, (ii) a bare adjectival complementive or (iii) a bare adposition (=verbal particle) can create an immobile V\*-unit. Second, Subsection VI has shown that there are also V\*-units like *touwtje springen* 'to skip' which cannot have a syntactic source and must therefore be listed as such in the lexicon. Although much is still unclear about the nature of these V\*-units, Subsection V suggested that there may be a syntactic reason for the fact that V\*-units like *touwtje springen* resist verb-second.

Subsections VII and VIII dealt with two additional types of V+X collocations that resemble *touwtje springen* in that they resist verb-second: typical examples are *vinger verven* 'to do finger painting' and *hand lezen* 'to palm read'. It turned out, however, that it is far more difficult to establish their type as the tests in the A- and B-column of Table 5 do not provide unequivocal results: speakers seem to be quite uncertain about how to use these collocations.

Subsection IX continued the discussion of immobile verbs with an investigation of complex particle verbs. Although such P+V collocations can normally be analyzed either as a phrasal V'-unit or as a V\*-unit, the former analysis is excluded for double particle verbs or particle verbs preceded by the prefix *her-*. Their V\*-status correctly predicts that they cannot undergo verb-second.

Subsection X concluded with a brief discussion of immobile particle verbs of the type *voorverkopen* 'to sell in advance' that have received relatively little attention in the literature so far. The discussion has shown that this type of immobile particle verbs exhibits the behavior typical of V\*-units.

### 10.3. Verb-first/second: special cases

This section discusses a number of special cases concerning the placement of finite verbs, which have in common that they pose (sometimes apparent) problems for the view that °verb-second is an obligatory and exclusive property of Dutch main clauses. Section 10.3.1 starts by discussing a class of main clauses in which verb-second fails to apply. Section 10.3.2 continues with a number of embedded adverbial clauses in which verb-second does apply. We will not discuss here the use of clauses introduced by the complementizer *dat* 'that' or *of* 'if' as independent utterances such as given in (104); for this, we refer the reader to Section 5.1.7.



- (104) a. Dat je dat kan!  
 that you that can  
 'It is amazing that you can do that!'
- b. En of ik dat wil!  
 and whether I that want  
 'I certainly want that!'

### 10.3.1. No Verb-first/second in main clauses?

This subsection discusses cases in which verb-second fails to apply in main clauses. The focus will be on clausal COMPARATIVE CORRELATIVE constructions of the form *hoe* A<sub>1</sub>-er ... *hoe* A<sub>2</sub>-er 'the more A1 ... the more A2'; example (105a) shows that such constructions have the finite verb of the main clause, which is given in italics, in clause-final position. In more formal language, the modifier *hoe* is sometimes substituted by *des te*; we will briefly discuss the fact that this is not always possible. We also pay some attention to cases such as (105b), which only occur as proverbs.

- (105) a. Hoe eerder je komt, *hoe beter het natuurlijk is.*  
 how sooner you come how better it of.course is  
 'The sooner you come, the better it is of course.'
- b. Wat niet weet, *wat niet deert.*  
 what not knows, what not hurts  
 'What one doesn't know can't hurt.'

Comparative correlative constructions express a positive correlation between two or more entities, properties, events etc. Two idiomatic examples are given in (106): example (106a) expresses a correlation between the number of people and the degree of enjoyment, and (106b) relates the time in the evening to the quality of the people present (normally used in jest, that is, as an ironic way of expressing a negative correlation between the two).

- (106) a. Hoe meer zielen, hoe meer vreugd. [idiom]  
 how more souls how more joy  
 'The more, the merrier.'
- b. Hoe later op de avond, hoe schoner volk. [idiom]  
 how later in the evening how more.beautiful folk  
 'The best guests always come late.'

Clausal comparative correlatives such as (107) are problematic in the light of the hypothesis that main clauses require the finite verb to be in first or second position. If the examples in (107) are complete (that is, non-reduced) sentences, we should conclude that at least one of the two constituting clauses functions as a main clause. Nevertheless, both clauses have the finite verb in clause-final position.

- (107) a. Hoe langer ik ernaar *kijk*, hoe meer ik erin *ontdek.*  
 how longer I at.it look how more I in.it discover  
 'The more I look at it, the more I discover in it.'
- b. Hoe groter een telescoop *is*, hoe meer licht hij *opvangt.*  
 how bigger a telescope is how more light he prt.-catches  
 'The bigger a telescope is, the more light it catches.'



According to Haeseryn et al. (1997:566), examples such as (107) alternate with examples such as (108), in which the second clause exhibits verb-second: the finite verb occurs right-adjacent to the clause-initial phrase *hoe meer N*. For this reason the first clause is analyzed as an adverbial phrase.

- (108) a. %Hoe langer ik ernaar *kijk*, hoe meer *ontdek* ik erin.  
 how longer I at.it look how more discover I in.it  
 ‘The longer I look at it, the more I discover in it.’
- b. %Hoe groter een telescoop *is*, hoe meer licht *vangt* hij *op*.  
 how bigger a telescope is how more light catches he prt.  
 ‘The bigger a telescope is, the more light it catches.’

The percentage signs in (108) indicate that according to us these examples are infelicitous; see Den Dikken (2003) for similar judgments. This might in fact be in line with the claim in Haeseryn et al. (1997) that verb-second is the less favored option in the case of *hoe* ‘how’; it is fully acceptable only if the modifier *hoe* ‘how’ is replaced by the more formal form *des te* (in which *des* is the old genitive form of the definite article), as in (109).

- (109) a. Hoe langer ik ernaar *kijk*, *des te* meer <ontdek> ik erin <ontdek>.  
 how longer I at.it look the TE more discover I in.it  
 ‘The longer I look at it, the more I discover in it.’
- b. Hoe groter een telescoop *is*, *des te* meer licht <vangt> hij *op* <vangt>.  
 how bigger a telescope is the TE more light catches he prt.  
 ‘The bigger a telescope is, the more light it catches.’

It is worth noting that, although both Haeseryn et al. and Den Dikken claim that the verb-second orders in (109) are the preferred ones, a Google search (1/6/2014) on the string [*hoe meer je \* des te meer*] has revealed that the °verb-final order is actually the more frequent one: we found 10 cases with and 17 cases without verb-second. This, in tandem with the fact that the verb-second order is often given as the preferred one in the more prescriptive literature (which is summarized at [taaladvies.net/taal/advies/vraag/1238](http://taaladvies.net/taal/advies/vraag/1238)), suggests that this order does not belong to Dutch °core grammar (the automatically required part of the language) but is part of the periphery (the consciously learned part); this would, of course, also be consistent with the fact that *des te meer* is part of the formal register. Because we do not have sufficient information for boosting this idea, we will leave the issue for future research and simply assume here that both orders in (109) are fully acceptable. Since the verb-second order is normally restricted to main clauses, its availability in (109) makes it plausible that the second clause functions as the main clause. This is also supported by the fact, illustrated in (110), that embedding such examples blocks verb-second; see Den Dikken (2003), who also notices that embedded constructions such as (109) are possible only with °bridge verbs like *zeggen* ‘to say’, *denken* ‘to think’, *vinden* ‘to find’, etc.

- (110) a. dat hoe langer ik ernaar *kijk*, *des te* meer <\*ontdek> ik erin <ontdek>.  
 that how longer I at.it look the TE more discover I in.it  
 ‘that the more I look at it, the more I discover.’

- b. dat hoe groter een telescoop is, des te meer licht <\*vangt> hij op <vangt>.  
 that how bigger a telescope is the TE more light catches he prt.  
 ‘that the bigger a telescope is, the more light it catches.’

In this connection it should be added that verb-second is restricted to the second clause; it is categorically rejected in the first clause. We refer the reader to Den Dikken (2003) for data that reveal a similar contrast between the two parts of the English comparative correlative construction *the more A<sub>1</sub> ... the more A<sub>2</sub>*.

The conclusion that the second clause is the actual main clause seems firmly grounded, but it also raises the question of the precise structure of the construction as a whole. That the phrase *des te meer* is left-adjacent to the finite verb in verb-second position in examples such as (109) suggests that this phrase occupies the initial position of the main clause. If correct, this would imply that the first clause is *external* to the main clause (and thus belongs to the class of elements to be discussed in Chapter 14); this is schematically represented in (111).

- (111) [clause hoe A-er ...], [main clause [hoe/des te A-er] ....]

Being external to the main clause is in fact not exceptional for adverbial-like clauses, as we also find this in conditional and concessive clauses like (112a&b), which will be discussed in more detail in Section 10.3.2. Such examples are also similar to comparative correlatives in that the main clauses are introduced by (or at least contain) some element that establishes a relation between the material external to the main clause and the main clause itself; the linking elements *dan* ‘then’ and *toch* ‘still/nevertheless’.

- (112) a. Als je wil komen, *dan* ben je welkom.  
 if you want come then are you welcome  
 ‘If you want to come, then you’re welcome.’  
 b. Ook al ben je sterk, *toch* ben je niet slim.  
 even though are you strong still are you not smart  
 ‘Even though you’re strong, you’re still not smart.’

It should be noted, however, that the similarity between comparative correlative and conditional/concessive constructions is not perfect: the linking elements *dan* ‘then’ and *toch* are resumptive in nature, so that we may be dealing with °left dislocation (cf. Section 14.2); the linking element in comparative correlatives (*hoe A<sub>2</sub>-er* ‘the more A<sub>2</sub>’), on the other hand, does not have any obvious resumptive function, so that a left-dislocation analysis seems less plausible.

The analysis suggested in (111) raises at least two non-trivial problems. The first problem is that we have to account for the fact that verb-second is not obligatory in the comparative correlative construction with *des te meer* in initial position (cf. (109)), and is even impossible in the corresponding constructions with *hoe* (cf. (108)). The second problem, which is probably related to the first one, involves the option of adding complementizers to the examples in (107). The resulting examples in (113) are perhaps less favored than those in (107), but seem grammatical and can all readily be found on the internet, as the reader can verify himself by performing a Google search on the string [*hoe meer (dat) je \*hoe meer (dat) je*]; examples such as (113) are also accepted by Den Dikken (2003) and

Paardekooper (1986:350/658); the latter reports to accept the complementizer *of* in this context as well.

- (113) a. Hoe langer dat ik ernaar *kijk*, hoe meer Ø ik erin *ontdek*.  
 a'. Hoe langer Ø ik ernaar *kijk*, hoe meer dat ik erin *ontdek*.  
 a''. Hoe langer dat ik ernaar *kijk*, hoe meer dat ik erin *ontdek*.  
 how longer that I at.it look how more that I in.it discover  
 'The longer I look at it, the more I discover in it.'  
 b. Hoe groter dat een *telescoop* is, hoe meer licht Ø hij *opvangt*.  
 b'. Hoe groter Ø een *telescoop* is, hoe meer licht dat hij *opvangt*.  
 b''. Hoe groter dat een *telescoop* is, hoe meer licht dat hij *opvangt*.  
 how bigger that a telescope is, how more light that he prt-catches  
 'The bigger the telescope, the more light it catches.'

Note in passing that Den Dikken (2003:9) claims that the primeless and doubly-primed examples in (113) cannot be replicated in the corresponding constructions with *des te*; his claim is, more specifically, that the complementizer *dat* cannot follow a *des te*-phrase in the first clause. However, this seems to be refuted by our Google search (2/7/2014), which came up with the pattern in (114), with “\$” indicating that we did not find this sentence type. Our search on the string [*des te meer dat \*des te*] resulted in 30 cases of the type in (114a), but did not yield cases of the type in (114c). The latter is in fact somewhat surprising given that the string [*des te \*des te meer dat*] did come up in various instances of the type in (114b). Due to the fact that *des te* is part of the formal register, it is somewhat difficult to provide acceptability judgments on these cases, and we will therefore not digress on these examples here.

- (114) a. Des te langer dat ik ernaar *kijk*, des te meer Ø ik erin *ontdek*.  
 b. Des te langer Ø ik ernaar *kijk*, des te meer dat ik erin *ontdek*.  
 c. <sup>\$</sup>Des te langer dat ik ernaar *kijk*, des te meer dat ik erin *ontdek*.  
 the TE longer that I at.it look the TE more that I in.it discover  
 'The longer I look at it, the more I discover in it.'

To the two problems for the analysis in (111), respectively, verb-second and the use of the complementizer, the fact that the complementizer need not be present in the verb-final construction should be added. The presumed main clause may thus occur in three different forms; the form in (115b) is the expected one, whereas the forms in (115a&c) are the unexpected, deviant ones.

- (115) a. [<sub>clause</sub> hoe A-er ...], [<sub>main clause</sub> [hoe/des te A-er] ... V<sub>finite</sub>]  
 b. [<sub>clause</sub> hoe A-er ... ], [<sub>main clause</sub> [des te/\*hoe A-er] V<sub>finite</sub> ... t<sub>V</sub>]  
 c. [<sub>clause</sub> hoe A-er ...], [<sub>main clause</sub> [hoe/des te A-er] dat ... V<sub>finite</sub>]

Den Dikken (2003) relates the grammaticality contrast between *hoe* and *des te* in the verb-second construction in (115b) to the fact that the phrase *hoe* A-er cannot normally occur in main-clause initial position, whereas *des te* A-er can. This is demonstrated in (116) by means of coordinate constructions with the adversative conjunction *maar* 'but', which expresses a negative correlation.

- (116) a. [<sub>main clause</sub> De boot vaart langzaam], maar  
           the boat sails slow but  
           [<sub>main clause</sub> des te/\*hoe meer kan je genieten van het uitzicht].  
           the TE/how more can you enjoy of the view  
           ‘The boat is sailing slowly but this allows you to enjoy the view all the more.’

If this line of thinking is correct, the availability of the structures in (115a&c) might be considered the result of a repair strategy for the comparative correlative construction with *hoe*, which has subsequently been extended by analogy to the corresponding construction with *des te*. We will not digress on this suggestion here, but leave it to future research.

As far as we know, the theoretical literature has been silent so far on the fact that comparative correlatives can sometimes be reduced. It seems at least plausible to provide a sluicing-like analysis to account for the similarity between the (a)- and (b)-examples in (117): the fact that the two *hoe*-phrases may precede the complementizer *dat* (if present) shows that they occupy the main-clause initial position (that is, SpecCP) as the result of *wh*-movement, and we may therefore be able to derive the (b)-examples from (117a) by means of deletion of the remainder of the clause (that is, IP). We leave this issue for future research, and refer the reader to Section 5.1.5 for the general outline of such an analysis.

- (117) a. Hoe eerder (dat) je het af hebt, hoe beter (dat) het is.  
           how sooner that you it completed have how better that it is  
           ‘The sooner you’ve finished it, the better it is.’  
       b. Hoe eerder (dat) je het af hebt, hoe beter.  
           how sooner that you it completed have how better  
       b’. Hoe eerder, hoe beter (dat) het is.  
           how sooner how better that it is  
       b’’. Hoe eerder, hoe beter.  
           how sooner how better

The discussion above has shown that comparative correlative constructions of the type in (115a&c) are indeed problematic for the otherwise robust generalization that main clauses have obligatory verb-second. To our knowledge there are no other *productive* constructions that violate this generalization but there are idiomatic constructions that systematically go against it. Some examples are given in (118).

- (118) a. Wat niet weet, wat niet deert. [proverb]  
           what not knows what not bothers  
           ‘What the eye doesn’t see the heart doesn’t grieve over.’  
       b. Wie dan leeft, wie dan zorgt. [proverb]  
           who then lives who then worries  
           ‘We’ll cross that bridge when we get to it.’  
       c. Wie niet waagt, wie niet wint. [proverb]  
           who not tries who not wins  
           ‘Nothing ventured, nothing gained.’  
       d. Wie het eerst komt, wie het eerst maalt. [proverb]  
           who the first comes who the first grinds  
           ‘First come, first served.’

The examples in (118), which can probably be seen as historical relics, all have the same overall structure: the first clause is a free relative and the second clause is introduced by a resumptive (demonstrative) pronoun that links the free relative to the main clause. The parallel form of the two clauses may suggest that they have the same internal structure, but this is actually not the case given that the non-idiomatic present-day counterpart of the examples in (118) would have verb-second in the second clause; this is illustrated for (118d) in (119) with and without a resumptive pronoun.

- (119) a. Wie het eerst komt, die <maalt> het eerst <\*maalt>. [literal]  
 who the first comes who grinds the first  
 ‘Who comes first gets the first shot at grinding.’
- b. Wie het eerst komt <maalt> het eerst <\*maalt>. [literal]  
 who the first comes grinds the first  
 ‘Who comes first gets the first shot at grinding.’

The examples in (119) suggest that the second clauses in the proverbs in (118) should be analyzed as main clauses too. We refer the reader to Den Dikken (2003) for the claim that the analyses of examples such as (118) and comparative correlatives can be unified by assuming that the non-main clauses in the latter construction are also free relatives, a property he claims to be characteristic for comparative correlatives cross-linguistically; cf. Den Dikken (2005).

To complete our discussion of the comparative correlative construction, we want to point out that comparative correlatives such as (117b'') should not be confused with *hoe ... hoe*-phrases of the type in (120a), which can be used as °complementives in, e.g., copular constructions; cf. A4.3.2.1, sub II. Since (120a') shows that finite clauses cannot be used as complementives in copular constructions, the suggested sluicing-analysis for (117b'') would not be suitable for such *hoe ... hoe*-phrases.

- (120) a. Het wordt hoe langer hoe beter.  
 it becomes how longer how better  
 ‘It is getting better and better.’
- b. \*Het wordt [dat het beter is].  
 it becomes that it better is

### 10.3.2. *Verb-first/second in embedded clauses?*

This subsection discusses a number of potential cases of embedded clauses with verb-first/second. The starting point of our discussion is the observation that verb-first/second is categorically rejected in finite argument clauses: object clauses, for instance, always have the form in (121a&b), with the obligatorily complementizer *dat* ‘that’ or *of* ‘if/whether’ and the finite verb in clause-final position; the primed examples show that finite argument clauses without a complementizer and with verb-second are excluded; see Section 5.1.1, sub II. Note that we marked the primed examples with a number sign because they are acceptable as cases of (semi-)direct reported speech, but this is, of course, not the reading intended here.

- (121) a. Jan zei [dat/\*Ø Els ziek was]. b. Jan vroeg [of/\*Ø Els ziek was].  
 Jan said that/Ø Els ill was Jan asked whether/\*Ø Els ill was  
 ‘Jan said that Els was ill.’ ‘Jan asked whether Els was ill.’  
 a’. #Jan zei [Els was ziek]. b’. #Jan vroeg [was Els ziek].  
 Jan said Els was ill Jan asked was Els ill

The generalization that verb-first/second cannot apply in finite embedded clauses does not only hold for argument clauses but is also quite robust for adverbial clauses. This is to be expected as such clauses are normally introduced by an obligatory complementizer-like linker that specifies the intended semantic relation with the main clause, such as causative *doordat* ‘because’ or concessive *hoewel* ‘although’ in (122). If we assume that such linkers occupy the same structural position as the complementizer *dat* in (121a), we immediately account for the fact that the finite verb must be in clause-final position as such linkers would then occupy the target position of verb-first/second; cf. Section 10.1.

- (122) a. *Doordat Els ziek · is*, kan ze vandaag niet werken.  
 because Els ill is can she today not work  
 ‘Because Els is ill, she cannot work today.’  
 b. *Hoewel Els ziek · is*, gaat ze vandaag werken.  
 although Els ill is goes she today work  
 ‘Although Els is ill, she’s going to work today.’

Nevertheless, it often appears as if verb-first/second applies in various types of adverbial clauses; cf. Haeseryn et al. (1997:1254ff). Subsections I to III discuss three types of such adverbial verb-first (V1) clauses: the prototypical and most frequent type is represented by the conditional construction in (123a); (123b&c) illustrate two less frequent types. Subsection IV continues with a discussion of concessive verb-second (V2) clauses such as (123d) introduced by (*ook/zelfs*) *al* ‘(even) though’, in which the adverbial clause has the verb in second position. We will show, however, that all italicized clauses in (123) are external to the main clause and conclude from this that run-of-the-mill, clause-internal adverbial clauses are always verb-final. Subsection V concludes with a number of potential counterexamples to this generalization, but shows that also for these cases it is plausible that the V1-clauses in question are not clause-internal.

- (123) a. *Is Els morgen ziek*, dan gaat ze niet werken. [conditional V1]  
 is Els tomorrow ill then goes she not work  
 ‘If Els is ill tomorrow, she won’t go to work.’  
 b. *Was Jan erg tevreden*, Peter was dat zeker niet. [contrastive V1]  
 was Jan very satisfied Peter was that certainly not  
 ‘Even if Jan was quite satisfied, Peter certainly wasn’t.’  
 c. *Helpt Marie iemand*, wordt ze door hem beroofd! [exclamative V1]  
 helps Marie someone is she by him robbed  
 ‘Imagine: Marie is helping someone and she gets mugged by him!’  
 d. *Ook al is Els ziek*, toch gaat ze vandaag werken. [concessive V2]  
 even though is Els ill still goes she today work  
 ‘Even though Els is ill, she’s still going to work today.’

Before starting the discussion, we want to point out that besides the instances in (123) there are other cases that are used especially in the formal register. We take the constructions in (123) to be representative of everyday usage and refer the reader for the more formal/obsolete cases such as the comparison construction in (124b) to Haeseryn et al. (1997:1391ff).

- (124) a. Alsof hij beter was dan anderen, zo gedroeg hij zich.  
 as.if he better was than others so behaved he REFL  
 ‘He behaved as if he was better than others.’  
 b. <sup>§</sup>Als was hij beter dan anderen, zo gedroeg hij zich.  
 as was he better than others so behaved he REFL

### *I. Conditional V1-clauses*

The italicized conditional clauses in (125) show that verb-second is optional: if the conditional clause is introduced by the linker element *als* ‘if’, the finite verb occurs in clause-final position but if *als* is not present, the finite verb must be clause-initial. There are grounds for assuming that the latter is possible in one specific context only, namely when the conditional clause is part of a °left-dislocation construction; cf. Den Besten (1983:fn.3), Haeseryn et al. (1997:section 21.8), Den Dikken (2003), and Beekhuizen (2008).

- (125) a. *Als het morgen regent*, dan ga ik naar de bioscoop.  
 if it tomorrow rains then go I to the cinema  
 ‘If it rains tomorrow, I’ll go to the cinema.’  
 b. *Regent het morgen*, dan ga ik naar de bioscoop.  
 rains it tomorrow then go I to the cinema  
 ‘If it rains tomorrow, then I’ll go to the cinema.’

That verb-first cannot apply in run-of-the mill adverbial clauses can be shown in at least two ways. First, the examples in (126) show that verb-first is marked if the resumptive element *dan* is not present. Example (126b) is marked with a percentage sign to indicate that this structure cannot easily be used to express the intended conditional reading; for the moment we will ignore that some speakers seem to allow this form but we will return to this in Subsection V.

- (126) a. *Als het morgen regent*, ga ik naar de bioscoop.  
 if it tomorrow rains go I to the cinema  
 ‘If it rains tomorrow, I’ll go to the cinema.’  
 b. <sup>%</sup>*Regent het morgen*, ga ik naar de bioscoop.  
 rains it tomorrow go I to the cinema  
 ‘If it rains, then I’ll go to the cinema.’

Second, the examples in (127) show that verb-first is also excluded if the adverbial clause is in clause-final position.

- (127) a. Ik ga naar de bioscoop *als het morgen regent*.  
 I go to the cinema if it tomorrow rains  
 ‘I’ll go to the cinema if it rains tomorrow.’  
 b. \*Ik ga naar de bioscoop *regent het morgen*.  
 I go to the cinema rains it tomorrow



A generalization that more or less presents itself on the basis of the examples in (125)-(127) is that conditional adverbial clauses allow verb-first only if they are clause-external. This is the case in left-dislocation constructions such as (125), in which the clause-initial position of the main clause is occupied by the resumptive element *dan* 'then', but not in examples such as (126), where the conditional clause occupies the clause-initial position itself or examples such as (127), where it occurs in clause-final position. The structures we would like to propose are given in (128).

- (128) a. [<sub>Cond-clause</sub> *Als het morgen regent*], [<sub>main-clause</sub> *dan ga ik naar de bioscoop*].  
 a'. [<sub>Cond-clause</sub> *Regent het morgen*], [<sub>main-clause</sub> *dan ga ik naar de bioscoop*].  
 b. [<sub>main-clause</sub> [<sub>Cond-clause</sub> *Als het morgen regent*] *ga ik naar de bioscoop*].  
 b'. \* [<sub>main-clause</sub> [<sub>Cond-clause</sub> *Regent het morgen*] *ga ik naar de bioscoop*].  
 c. [<sub>main-clause</sub> *Ik ga naar de bioscoop*] [<sub>Cond-clause</sub> *als het morgen regent*].  
 c'. \* [<sub>main-clause</sub> *Ik ga naar de bioscoop*] [<sub>Cond-clause</sub> *regent het morgen*].

Observe that verb-first is also excluded in parenthetical conditional clauses, as shown by the examples in (129). Since it can be argued that parenthetical clauses are not structurally embedded in the main clause, this shows that being external to the main clause cannot be considered a sufficient condition for allowing verb-first.

- (129) a. *Ik ga morgen, als het (tenminste) regent, naar de bioscoop.*  
 I go tomorrow if it at.least rains to the cinema  
 'I'll go to the cinema tomorrow, at least if it rains.'  
 b. \**Ik ga morgen, regent het (tenminste), naar de bioscoop.*  
 I go tomorrow rains it at.least to the cinema

Note in passing that we can identify parenthetical clauses by means of the phrase *tenminste* 'at least'; addition of this phrase to the examples in (125) and (126a) gives rise to severely marked results but it is easily possible in (129a). It is possible in (127a), but this requires the adverbial clause to be preceded by an intonation break.

That left-dislocated phrases are indeed clause-external is also shown by examples like (130) and (131). In (130), the main clause is an imperative, and since imperative clauses always have the finite verb in first position, the *als*-clause cannot be clause-internal. The same holds for the examples in (131), in which the main clause is a *yes/no*-question.

- (130) a. *Als je morgen daar bent, help hem <sup>\*?</sup>(dan) een beetje!*  
 if you tomorrow there are help him then a bit  
 'If you're there tomorrow, do help him a bit!'  
 b. *Ben je morgen daar, help hem <sup>\*?</sup>(dan) een beetje!*  
 are you tomorrow there help him then a bit  
 'If you're there tomorrow, do help him a bit!'
- (131) a. *Als je morgen daar bent, help je hem <sup>\*?</sup>(dan) een beetje?*  
 if you tomorrow there are help you him then a bit  
 'If you're there tomorrow, will you help him a bit then?'  
 b. *Ben je morgen daar, help je hem <sup>\*?</sup>(dan) een beetje?*  
 are you tomorrow there help you him than a bit  
 'If you're there tomorrow, will you help him a bit then?'



Observe that the V1-requirement of the main clauses in (130) and (131) makes it necessary to place the resumptive element *dan* in the middle field of the clause. The examples in (132) show that this option is not available in declarative main clauses: the resumptive element must be placed in clause-initial position as in the acceptable examples in (125) above.

- (132) a. \*Als het morgen regent, ik ga *dan* naar de bioscoop.  
 if it tomorrow rains I go then to the cinema  
 b. \*Regent het morgen, ik ga *dan* naar de bioscoop.  
 rains it tomorrow I go then to the cinema

The hypothesis that verb-first is possible only if the conditional adverbial clause is left-dislocated predicts that embedding the two examples in (125) will not give rise to an acceptable result, given that left dislocation is a property of root clauses. The unacceptability of (133b) shows that this is indeed what we find for (125b). The case for (125a) is less straightforward in the light of the acceptability of (133a), but the fact that addition of the resumptive element *dan* is impossible (regardless of its position in the °matrix clause) shows that a left-dislocation analysis is not appropriate. That addition of *tenminste* ‘at least’ to the conditional clause is possible in fact suggests that we are dealing with a parenthetical clause; see the discussion of (129).

- (133) a. Ik denk dat *als het morgen (tenminste) regent* ik naar de bioscoop ga.  
 I think that if it tomorrow at.least rains I to the cinema go  
 ‘I think that if it rains tomorrow, I’ll go to the cinema.’  
 b. \*Ik denk dat *regent het morgen* ik naar de bioscoop ga.  
 I think that rains it tomorrow I to the cinema go

That the addition of the resumptive linking element *dan* ‘then’ to example (133a) leads to unacceptability suggests that the presence of this element is a reliable clue for assuming left dislocation. If so, this supports the hypothesis based on the acceptability contrast between the examples in (125) and in (126)/(127) that verb-first is restricted to left-dislocated clauses.

Before concluding this subsection, we will briefly address two issues that may complicate the investigation of conditional V1-clauses but which have received hardly any attention in the syntactic literature so far. First, the argument built on embedding is complicated by the fact that besides examples such as (133a) it is often possible to have constructions such as (134a), with two complementizers *dat* and the resumptive element *dan*. It is not a priori clear whether such an example should be seen as the embedded counterpart of (125a) or whether we are dealing here with a performance phenomenon: processing of the embedded clause in (133a) may be hampered by the lengthy interruption of the parenthetical conditional clause, and resumption of the part preceding the parenthetical clause may therefore be seen as a repair strategy. The fact that example (125b) does not have such a “counterpart” is unexpected under the first approach and thus favors the second approach.

- (134) a. Ik denk *dat* als het morgen regent *dat* ik dan naar de bioscoop ga.  
 I think that if it tomorrow rains that I then to the cinema go  
 ‘I think that if it rains tomorrow, I’ll go to the cinema.’
- b. \*Ik denk *dat* regent het morgen *dat* ik *dan* naar de bioscoop ga.  
 I think that rains it tomorrow that I then to the cinema go

Note in passing that, although examples such as (134a) seem quite outlandish at first sight, they are actually quite frequent; a Google search (2/12/2014) on the string [*dat als je \* dat je dan*] resulted in 264 hits, the vast majority of which instantiate the intended construction. We refer the reader to Section 14.2 for a discussion of a wider range of utterances of this type.

A second complicating issue is that in coordinate structures such as (135) verb-second may apply in the second conjunct if the linker *als* is not realized; cf. Haeseryn et al. (1997:1252). At first sight, this seems to confirm the earlier established fact that the position of the finite verb in left-dislocated conditional clauses depends on the presence of *als*, but closer scrutiny reveals that the second conjunct in (135b) differs conspicuously from the cases discussed earlier in that its clause-initial position is filled by the subject; example (135c) shows that this is normally excluded in conditional clauses.

- (135) a. Als ik het niet weet of *als ik erover twijfel*, dan vraag ik het.  
 if I it not know or if I about.it doubt then ask I it  
 ‘If I don’t know it or if I doubt it, I (will) ask it.’
- b. Als ik het niet weet of *ik twijfel erover*, dan vraag ik het.  
 if I it not know or I doubt about.it then ask I it  
 ‘If I don’t know it or if I doubt it, I (will) ask it.’
- c. \*Ik *twijfel erover*, dan vraag ik het.  
 I doubt about.it then ask I it

This raises the following question: are we really dealing with coordination in (135b) or should the presumed second conjunct be analyzed as a parenthetical clause? That is: should (135b) be analyzed along the line in (136a) or the one in (136b)? We will leave this issue to future research.

- (136) a. [[Als ik het niet weet] of [ik twijfel erover]], dan vraag ik het.  
 b. Als ik het niet weet —of ik twijfel erover— dan vraag ik het.

If we put these two complicating issues aside for the moment, we may conclude that the generalization that verb-first/second is excluded in embedded clauses can be maintained. The research question we still need to answer, however, is not “how is it that certain types of embedded clauses sometimes exhibit verb-first/second” but instead “how is it that left-dislocated clauses can sometimes take the form of either a main or a non-main clause”?

## II. Contrastive V1-clauses

The conditional construction in (137a) and the contrastive construction in (137b) are similar in that the V1-clauses are not part of the main clause. This is clear from the fact that the initial position of the main clause is filled by some other constituent: the resumptive element *dan* in (137a) and the subject *Jan* in (137b). The primed

examples show that the V1-clauses cannot occupy the initial position themselves; recall that we have postponed discussion of the fact that some speakers do seem to allow (137b') to Subsection V.

- (137) a. *Regent het morgen*, dan ga ik naar de bioscoop.  
 rains it tomorrow then go I to the cinema  
 'If it rains tomorrow, then I'll go to the cinema.'
- a'. %*Regent het morgen*, ga ik naar de bioscoop.  
 rains it tomorrow go I to the cinema
- b. *Gaat Peter graag uit*, Jan zit liever thuis.  
 goes Peter gladly out Jan sits rather at.home  
 'Whereas Peter likes to go out, Jan prefers to stay at home.'
- b'. \**Gaat Peter graag uit*, zit Jan liever thuis.  
 goes Peter gladly out sits Jan rather at.home

At first sight, the primeless examples in (138) seem to show that the two V1-clauses in (137) both alternate with across-the-board adverbial clauses introduced by a complementizer and with the finite verb in clause-final position. Closer scrutiny shows, however, that this is not the case. The optionality of *dan* in (138a) reveals that the *als*-clause could be either left-dislocated or clause-internal, that is, located in the initial position of the main clause. It is of course only the left-dislocated clause that can be considered an alternant of the similarly left-dislocated V1-clause in (137a). The fact that the *terwijl*-clause in (138b) triggers subject-verb inversion in the main clause shows that it occupies the clause-initial position and can consequently not be seen as an alternant of the left-dislocated V1-clause in (137b). We could conclude that contrastive V1-clauses alternate with *terwijl*-clauses if it is possible to have *terwijl*-clauses without subject-verb inversion, but (138b') shows that this is not the case.

- (138) a. *Als het morgen regent*, (dan) ga ik naar de bioscoop.  
 if it tomorrow rains then go I to the cinema  
 'If it rains tomorrow, (then) I'll go to the cinema.'
- b. *Terwijl Peter graag uitgaat*, zit Jan liever thuis.  
 while Peter gladly out-goes sits Jan rather at.home  
 'Whereas Peter likes to go out, Jan prefers to stay at home.'
- b'. \**Terwijl Peter graag uitgaat*, Jan zit liever thuis.  
 while Peter gladly out-goes Jan sits rather at.home  
 'Whereas Peter likes to go out, Jan prefers to stay at home.'

The examples in (138) thus show that the alternation occurs with the conditional construction only. This should be related to another conspicuous difference between the two constructions; while Subsection I has shown that the resumptive element *dan* is obligatory in the conditional construction, resumption does not seem possible in the contrastive construction. This suggests that while the conditional V1-clause (indirectly) plays a semantic role in the main clause, this does *not* hold for the contrastive V1-clause because it is not connected to the main clause by formal means (like resumption).

The fact that the syntactic tie between the two clauses is tighter in the conditional than in the contrastive construction is reflected by the semantics of the two constructions. In the conditional construction, there is an intimate relationship between the truth of the propositions expressed by the V1-clause and the main clause, which is normally expressed in propositional calculus by the °material implication in (139a). In the contrastive construction, on the other hand, the V1-clause and the main clause are used to independently assert a proposition, as expressed by the conjunction in (139b). The crucial difference between the two formulas is that conjunctions but not material implications are expressed by means of independent clauses.

- (139) a. conditional construction:  $p \rightarrow q$   
 b. contrastive construction:  $p \wedge q$

Subsection I has shown that the resumptive element *dan* in conditional constructions must occupy the clause-initial position of a declarative main clause; see the contrast between the examples in (125b) and (132b), repeated here for convenience as (140). This would imply that the initial position plays a special role in the connection of the clauses.

- (140) a. *Regent het morgen, dan ga ik naar de bioscoop.*  
 rains it tomorrow then go I to the cinema  
 ‘If it rains tomorrow, then I’ll go to the cinema.’  
 b. \**Regent het morgen, ik ga dan naar de bioscoop.*  
 rains it tomorrow I go then to the cinema

Although there is no resumptive element in the contrastive construction, it seems that there are also restrictions here on the element in the first position of the declarative main clause. In order to clarify this we first have to digress on the meaning of the construction. As the name of the construction already suggests, the key issue is the notion of CONTRAST. What is contained in this notion can be clarified by considering the larger sample of examples in (141); the notion of contrast applies to the italicized elements, and the underlined phrases occupy the initial positions of the main clauses; cf. Beekhuizen (2008).

- (141) a. Gaat *Peter* graag uit, Jan zit meestal liever thuis. [entity]  
 goes Peter gladly out Jan sits generally rather at.home  
 ‘While Peter likes to go out, Jan prefers to stay at home.’  
 b. Was Marie *vroeger* arm, nu is ze erg rijk. [time]  
 was Marie in.the.past poor, now is she very wealthy  
 ‘While Marie used to be poor, she’s now very wealthy.’  
 c. Praat Jan *bij Els* heel veel, bij mij is hij heel stil. [location]  
 talks Jan with Els very much with me is he very quite  
 ‘While Jan is talkative with Els, with me he’s quite silent.’

The italicized elements are topical and contrastive in the sense that the non-italicized parts of the clauses provide mutually incompatible comments on these elements: the comments in (141b), for instance, can be translated as the lambda expressions  $\lambda x$  POOR(x) and  $\lambda x$  RICH(x), which are mutually incompatible in the

sense that  $\lambda$  conversion cannot involve a single entity  $e$  as is clear from the fact that the formula POOR( $e$ ) & RICH( $e$ ) is contradictory. The semantic function of the topical elements is to add information that resolves the contradiction, as is clear from the fact that the informal predicate logic translations of the examples in (141) given in (142) are fully coherent.

- (142) a. WANT TO GO OUT( $p$ ) & RATHER STAY AT HOME( $j$ )  
 b.  $\exists t_1$  [POOR( $m$ )  $\wedge$   $t_1$  < now] &  $\exists t_2$  [RICH( $m$ )  $\wedge$   $t_2$  = now]  
 c.  $\exists p_1$  [TALKS A LOT( $j$ )  $\wedge$   $p_1$  = with Els] &  $\exists p_2$  [SILENT ( $j$ )  $\wedge$   $p_2$  = with me]

Beekhuizen (2008) observes that in some cases the relevant notion is not contrast but unexpectedness or, perhaps even better, concessiveness. The comments in example (143a), for example, are not contradictory but instead tautologous in nature. For example, the formula GOOD SOPRANO( $e$ ) & ABLE TO SING WELL( $e$ ) is tautologous in the sense that the denotation of GOOD SOPRANO is included in the denotation of ABLE TO SING WELL. Again the topical elements resolve the tautology, as is shown in the informal predicate logic translation in (143b). Observe that concessive examples can often be recognized by the fact that the topical element in the main clause can be preceded by the focus particle *ook* 'too'; adding this particle to the contrastive examples in (141) leads to a semantically incoherent result.

- (143) a. Is Els een goede sopraan, ook Marie kan goed zingen.  
 is Els a good soprano also Marie can well sing  
 'Although Els is a good soprano, Marie also sings well.'  
 b. GOOD SOPRANO( $e$ ) & ABLE TO SING WELL( $m$ )

In his newspaper corpus Beekhuizen found that the topical elements normally refer to entities (including individuals) and aspects of the spatio-temporal settings of the propositions expressed by the two clauses. Given the semantic discussion above, this does not come as a surprise as these settings are especially suitable in resolving the contradictory/tautologous nature of the comments. Beekhuizen also found that in more than 90% of the attested cases, the initial position of the declarative main clause is occupied by the topical element. That this position is a designated position for such elements is also clear from the fact illustrated in (144) that changing the word orders of the main clauses gives rise to less felicitous results. Note that we used the diacritic "\$" to express this because the main clauses are fully acceptable without the contrastive V1-clauses and there is consequently no *a priori* reason for assuming that the examples in (144) are syntactically ill-formed; italics and underlining are used in the same way as in (141).

- (144) a.  $\S$ Gaat *Peter* graag uit, meestal zit *Jan* liever thuis. [entity]  
 goes Peter gladly out generally sits Jan rather at.home  
 'Whereas Peter likes to go out, Jan generally prefers to stay at home.'  
 b.  $\S$ Was Marie *vroeger* arm, ze is *nu* erg rijk. [time]  
 was Marie in.the.past poor, she is now very wealthy  
 'Whereas Marie used to be poor, she's now very wealthy.'  
 c.  $\S$ Praat Jan bij Els heel veel, hij is *bij mij* heel stil. [location]  
 talks Jan with Els very much he is with me very quite  
 'Whereas Jan is talkative with Els, with me he's quite silent.'

The fact that the topical constituent must occupy the initial position of the declarative main clause is again not surprising, given that contrastive topic/focus elements are generally found in this position; cf. Section 11.3.2. It is perhaps remarkable, however, that it does not seem possible to use contrastive accent to improve the examples in (144) while this is possible in contrastive coordination constructions such as (145), in which small caps indicate focus accent.

- (145) a. Marie was VROEGER arm, maar NU is ze erg rijk.  
 Marie was in.the.past poor but now is she very wealthy  
 ‘Whereas Marie used to be poor, she’s now very wealthy.’  
 b. Marie was VROEGER arm, maar ze is NU erg rijk.  
 Marie was in.the.past poor but she is now very wealthy  
 ‘Whereas Marie used to be poor, she’s now very wealthy.’

This contrast between the two construction types may be related to the fact that the declarative clauses in examples such as (141) are probably not contrastive focus constructions but contrastive topic constructions, that is, have contrastive accent on the topical element, with an additional accent in the comment of the clause: it is difficult to get this accent pattern if the topical element occupies a position in the middle field of the clause: <sup>??</sup>*Ze is NU erg RIJK.*

- (146) a. Gaat Peter graag UIT, JAN zit meestal liever THUIS.  
 goes Peter gladly out Jan sits generally rather at.home  
 ‘Whereas Peter likes to go out, Jan prefers to stay at home.’  
 b. Was Marie vroeger ARM, NU is ze erg RIJK.  
 was Marie in.the.past poor now is she very wealthy  
 ‘Whereas Marie used to be poor, she’s now very wealthy.’  
 c. Praat Jan bij Els heel VEEL, bij MIJ is hij heel STIL.  
 talks Jan with Els very much with me is he very quite  
 ‘Whereas Jan is talkative with Els, with me he’s quite silent.’

Beekhuizen further found that the associate of the topical element in the contrastive V1-clause often precedes the subject. The examples in (147) show that this is not always possible but that it depends on the information-structural properties of the subject: while definite subjects may follow the adverbial phrase *in 2013* if they are part of the discourse-new information, this is impossible for presuppositional subject pronouns like *hij* ‘he’. This seems to fit in with the word order generalizations discussed in Section 13.2.

- (147) a. Was in 2013 mijn buurman werkeloos, nu kan hij overal werken.  
 was in 2013 my neighbor jobless now can he anywhere work  
 ‘Although my neighbor was jobless in 2013, he can work anywhere now.’  
 b. Was <hij> in 2013 <\*hij> werkeloos, nu kan hij overal werken.  
 was he in 2013 jobless now can he anywhere work  
 ‘Although he was jobless in 2013, he can work anywhere now.’

In the examples above the topical constituent has the same syntactic function as its associate in the contrastive V1-clause. The examples in (148) show, however that this need not be the case: (148) shows that a subject may be contrasted with an

agentive *door*-phrase, which shows that it is sufficient if the topical elements have a similar semantic function.

- (148) Beweert Jan dat Els ziek is, door Marie wordt dit ontkend.  
 claims Jan that Els ill is by Marie is this denied  
 ‘Whereas Jan claims that Els is ill, this is denied by Marie.’

This section has shown that contrastive/concessive V1-clauses are external to the main clause and therefore do not constitute counterexamples to the generalization that dependent clauses do not allow V-first/second. We have also seen evidence that such V1-clauses differ from conditional V1-clauses in that they are not left-dislocated and do not alternate with run-of-the-mill adverbial clauses introduced by some linker. From a syntactic point of view contrastive V1-clauses are less intimately related to the following main clause than conditional V1-clauses, due to the lack of resumption.

### III. Exclamative V1-clauses

The exclamative constructions in (149) are taken from Van der Horst & Van der Horst (1999:266) in a slightly adapted version. Examples like these are characterized by a typical exclamative intonation pattern; small caps indicate contrastive accent and the exclamation mark the exclamative intonation contour. Exclamative constructions are normally used to express an emotional attitude of the speaker towards the propositional content: amazement, vexation, indignation, etc.

- (149) a. ZIJN we eindelijk in Parijs, REgent het de hele dag!  
 are we finally in Paris rains it the whole day  
 ‘We’ve finally managed to get to Paris and it’s been pouring all day!’  
 b. HEEFT hij eindelijk een baan, komt hij niet OPdagen!  
 has he finally a job, comes he not up-show  
 ‘At last he has a job and what does he do? He doesn’t show up!’

At first sight examples such as (149) look very similar to the marked conditional constructions with a conditional V1-clause and without the resumptive element *dan* ‘then’, the discussion of which we have postponed to Subsection V. This is a visual deception, however: in speech the intonation pattern would immediately distinguish the two. Furthermore, the two have quite different meanings. A nice illustration of this is given by Van der Horst & Van der Horst; they quote an advertisement slogan for Croma, a brand of frying fat:

- (150) a. <sup>%</sup>Hou je van vlees, braad je in Croma. [conditional]  
 like you of meat fry you in Croma  
 ‘If you like meat, then you fry [it] in Croma.’  
 b. HOU je van vlees, braad je in CROMA! [exclamative]  
 like you of meat fry you in Croma  
 ‘How can you be so stupid: You like meat and you fry [it] in Croma.’

The conditional use in (150a) was of course the one intended; if one gave this slogan an exclamative intonation pattern, it would give rise to a reading expressing utter disapproving amazement, which we tried to express by means of the



translation in (150b). The translation also expresses that the exclamative construction has no conditional import: the speaker simply asserts that the propositions expressed by the two clauses are both true. There is a relation between the two propositions, though, in that it is the truth of the proposition expressed by the first clause that makes the truth of the proposition expressed by the second clause so surprising; see Beekhuizen (2008: Section 4) for more discussion. Note in passing that the second person pronoun *je* can readily be given a generic interpretation in examples such as (150a) leading to the interpretation “Anyone who likes meat fries in Croma” but that the second person pronoun must refer to the addressee in (150b); it may be interesting to note in this connection that Beekhuizen found a fairly large number of generic exclamative constructions in his newspaper corpus.

Exclamative examples such as (149) never involve a resumptive element, which may indicate that the first V1-clause is in the initial position of the second clause. However, this would run afoul of our earlier conclusion on the basis of conditional and contrastive constructions that V1-clauses are always clause-external. Let us then consider the alternative that the first clause is external to the second clause, although it is not easy to find convincing arguments for/against the two options. It would be an argument in favor of the first option if the V1-clause could also appear in some other clause-internal position, but the examples in (151) show that this is not the case.

- (151) a. [ZIJN we eindelijk in Parijs], REgent het de hele dag! [= (149a)]  
 are we finally in Paris rains it the whole day  
 ‘We’ve finally managed to get to Paris and it’s been pouring all day!’  
 b. \*Het regent [zijn we eindelijk in Parijs] de hele dag!  
 c. \*Het regent de hele dag [zijn we eindelijk in Parijs]!

The examples in (151) suggest instead that the first V1-clause is external to the second one. It would be an argument in favor of such an analysis if the contrastive V1-clause could also occur syntactically independent of the second one. The coordination constructions in (152), which are based on the examples in (149) and (150b), show that this is indeed possible.

- (152) a. ZIJN we eens in Parijs, en dan REgent het de hele dag!  
 are we PRT in Paris and then rains it the whole day  
 b. HEEFT hij eindelijk een baan, en dan komt hij niet OPdagen!  
 has he finally a job, and then comes he not up-show  
 c. HOU je van vlees en dan braad je in CROMA!  
 like you of meat and then fry you in Croma

In fact, the examples in (153), which again are modelled on example (152b), show that the first clause need not even be coordinated with a declarative clause, but can also be coordinated with an interrogative clause, or a demonstrative pronoun/referential noun phrase preceded by *dan*.



- (153) a. HEEFT hij eindelijk een baan, en wat zegt hij?!  
 has he finally a job, and what says he  
 'At last he has a job and what does he say?'
- b. HEEFT hij eindelijk een baan, en dan dit/zo'n reactie!  
 has he finally a job, and then this/such a reaction  
 'At last he has a job and then this happens/we get such a reaction.'

It would be another argument for assuming that the first clause is external to the second one if the second clause could be used as an independent exclamative V1-clause in other contexts. The examples in (154) strongly suggest that the exclamative constructions in (149) and (150b) involve show that this is also possible.

- (154) a. We zijn eindelijk in Parijs. En wat denk je: Regent het de hele dag!  
 we are finally in Paris. and what think you: rains it the whole day  
 'Finally, we're in Paris. And, guess what, it is raining all day!'
- b. Hij heeft eindelijk een baan. En wat denk je: komt hij niet opdagen!  
 he has finally a job and what think you comes he not up-show  
 'He finally has a job. And, guess what, he doesn't turn up!'
- c. Hij houdt van vlees. En wat denk je: braadt hij in Croma!  
 he likes of meat. and what think you fries he in Croma  
 'He likes meat. And, guess what, he fries in Croma!'

Examples (152) and (154) strongly suggest that the exclamative constructions in (149) and (150b) involve juxtaposed clauses, which in fact ties in nicely with the observation that exclamative constructions of this sort are typical of speech because exclamative V1-constructions of the type in (152) and (154) are also relatively rare in written language. If the juxtaposition analysis is indeed correct, exclamative V1-clauses are well-behaved with respect to our hypothesis that V1-clauses cannot occur clause-internally.

#### *IV. Concessive V2-clauses*

In the introduction to this section, we have seen that concessive clauses come in at least two varieties, repeated here in a slightly different form as (155a&b). The concessive clause in (155a) is an ordinary adverbial clause: the impossibility of including the particle *toch* in the initial position of the main clause shows that it must occur clause-internally and, in keeping with our hypothesis that V1-clauses cannot occur clause-internally, it is introduced by the complementizer-like element *hoewel* 'although' and has the finite verb in clause-final position. The concessive clause in (155b), on the other hand, must be external to the main clause, as is clear from the fact that the particle *toch* in the first position of the main clause cannot be omitted. Concessive main clauses such as (155b) differ from the conditional clauses discussed in the subsection I in that they do not have an alternant with the finite verb in clause-final position; examples such as (155b') are unacceptable.

- (155) a. *Hoewel Els ziek is, (\*toch) gaat ze vandaag werken.*  
 although Els ill is, still goes she today work  
 ‘Although Els is ill, she’s still going to work today.’
- b. *Ook al is Els ziek, \*(toch) gaat ze vandaag werken.*  
 even though is Els ill still goes she today work  
 ‘Even though Els is ill, she’s still going to work today.’
- b'. *\*Ook al Els ziek is, toch gaat ze vandaag werken.*  
 even though Els ill is still goes she today work

The reason for the ungrammaticality of (155b') might be that examples such as (155b) cannot be analyzed as left-dislocation constructions; see the discussion of contrastive construction in Subsection II. If (155b) were a case of °left dislocation, we would expect the particle *toch* to be analyzed as a resumptive element linked to the concessive clause, but this is rather unlikely, given that example (156a) shows that this particle can also be used in examples with a clause-internal concessive clause: if *toch* were a resumptive element, example (156a) would have two constituents performing an identical syntactic function. Furthermore, example (156b) shows that *toch* differs from conditional *dan* in that it need not be clause-initial in declarative clauses; it can in fact even be left out entirely, although Haeseryn et al. (1997:1391) claim that this is a feature especially found in written texts.

- (156) a. *Hoewel Els ziek is gaat ze vandaag toch werken.*  
 although Els ill is goes she today still work  
 ‘Although Els is ill, she’s still going to work today.’
- b. *Ook al is Els ziek, ze gaat vandaag (toch) werken.*  
 even though is Els ill she goes today still work  
 ‘Even though Els is ill, she’s (still) going to work today.’

The ungrammaticality of (155b') is also related to the status of the element (*ook*) *al* ‘even though’. We have seen that we can account for the complementary distribution of *als* and the finite verb in initial position of left-dislocated conditional clauses by assuming that *als* is a complementizer occupying the C-position, that is, the target position of verb-first/second. The fact that (*ook*) *al* does not block verb-second shows that it is a regular phrase in clause-initial position and not a complementizer-like element. This is also consistent with the fact, illustrated in (157a&b), that some other constituent will normally be moved into this position if (*ook*) *al* is omitted. The conclusion that (*ook*) *al* is a phrase occupying the clause-initial position of the concessive clause correctly predicts that it cannot license the clause-final placement of the finite verb in (155b').

- (157) a. *Ook al was de reclame groot, toch bleef het succes maar klein.*  
 even though was the publicity big still stayed the success PRT small  
 ‘Even though there was a lot of publicity, the success was small.’
- b. *De reclame was groot, toch bleef het succes maar klein.*  
 the publicity was big still stayed the success PRT small  
 ‘There was a lot of publicity, still the success was small.’

Note in passing that Haeseryn et al. (1997:1392) claim that the omission of (*ook*) *al* does not require some other constituent to be moved into clause-initial position: they consider *Was de reclame groot, toch bleef het succes maar klein* possible in the formal register. According to us, this example is artificial and obsolete; see Van der Horst (2008) for a similar example from Old Dutch (p.337) and the claim that the construction with *al* is already common in Middle Dutch (p.773-4).

That concessive clauses introduced by (*ook*) *al* have the hallmarks of regular main clauses seems to fit in nicely with our earlier conclusion that a left-dislocation analysis is not possible; they must therefore be analyzed as independent main clauses. This is also suggested by yet another difference from conditional clauses. The (a)-examples in (158), repeated from Subsection I, show that conditional clauses in extraposed position must be introduced by *als* and therefore do not allow movement of the finite verb. Example (158b), on the other hand, shows that placing the concessive clause last does not affect its form; this shows again that it cannot function as a regular adverbial clause.

- (158) a. Ik ga naar de bioscoop *als* het morgen regent.  
 I go to the cinema if it tomorrow rains
- a'. \*Ik ga naar de bioscoop *regent* het morgen.  
 I go to the cinema rains it tomorrow
- b. Het succes bleef maar klein, ook al was de reclame groot.  
 the success stayed prt small even though was the publicity big  
 'The success was small even though there was a lot of publicity.'

The discussion above leaves us with the question as to what kind of structure is plausible for the concessive constructions under discussion. The first thing that comes to mind is that we are dealing with two juxtaposed main clauses and this may in fact be a plausible analysis for examples such as (157b), given that (159a) shows that we may also coordinate the two clauses by means of the conjunction *maar* 'but' and that the first clause can readily be used independently. This does not hold for examples such as (157a): the use of *maar* 'but' in (159b) gives rise to a degraded result and the independent use of the first clause in (159b') has some sense of incompleteness (indicated by the diacritic "\$" and a series of dots).

- (159) a. De reclame was groot (maar toch bleef het succes maar klein).  
 the publicity was big but still stayed the success only small  
 'There was a lot of publicity, still the success was small.'
- b. \*Ook al was de reclame groot (maar toch bleef het succes maar klein).  
 even though was the publicity big but still stayed the success only small
- b'. <sup>S</sup>Ook al was de reclame groot, ...

It follows that the examples in (159) suggest that a simple juxtaposition analysis might not be the right answer. Since we do not have any further insights to offer at this point, we leave the question unresolved as to the internal structure of the concessive construction under discussion, while concluding that this does not jeopardize the generalization that verb-first/second is excluded in dependent clauses.

## V. Some potential problems

The previous subsections have shown for a number of adverbial-like V1/2-clauses that they are clause-external, and thus support the hypothesis that verb-first/second is impossible in the case of average (clause-internal) adverbial clauses. This subsection considers some potential counterexamples to this hypothesis. The first case was already mentioned in our earlier discussion but put aside. Consider again the examples in (160). Example (160b) is normally considered infelicitous but we marked it with a percentage sign, as Van der Horst & Van der Horst (1999:256ff) provide a large number of attested conditional V1-clauses without resumptive *dan* from various written sources such as newspapers, belles-lettres, advertisements, etc.

- (160) a. Als het morgen regent (dan) ga ik naar de bioscoop.  
 if it tomorrow rains then go I to the cinema  
 'If it rains tomorrow (then) I'll go to the cinema.'
- b. Regent het morgen, % (dan) ga ik naar de bioscoop.  
 rains it tomorrow then go I to the cinema  
 'If it rains tomorrow then I'll go to the cinema.'

Van der Horst & Van der Horst claim that examples of this type are a recent innovation that became especially popular in the 1980's although they also found some cases from the 14<sup>th</sup> century onwards; the examples in (161) show that there are even a number of proverbs of this form.

- (161) a. Komt tijd, komt raad.  
 comes time comes council  
 Approximately: 'Time brings counsel.'
- b. Baadt het niet, (dan) schaadt het niet.  
 helps it not then harms it not  
 'It can't do any harm and it may do some good.'

Van der Horst & Van der Horst (1999:256ff) provide an analysis according to which conditional V1-clauses are clause-internal if *dan* is not present, and claim that this has become possible in analogy to constructions with *als*-clauses. They further suggest that the rise of clause-internal conditional V1-clauses is to be expected as this *eliminates an irregularity* from the system by allowing all dependent clauses to occur clause-internally. From our perspective, however, such a change would *introduce an irregularity* into the system because it goes against the well-supported hypothesis that V1-clauses are categorically rejected in clause-internal position. This hypothesis can be saved, however, if we assume that constructions with conditional V1-clauses but without resumptive *dan* are not part of Dutch °core grammar.

Two options present themselves. One possibility, which is also considered by Van der Horst & Van der Horst, is built on the observation that the use of resumptive *dan* is a property of spoken language, that is, it is disfavored in written language; its omission in constructions with conditional V1-clauses may therefore be a case of hypercorrection. Another possibility appeals to the fact that some speakers allow omission of resumptive elements in clause-initial position. If correct, the analysis of the constructions with conditional V1-clauses without resumptive

*dan* would be as given in (162a). This would give rise to the expectation that speakers who allow (162a) also allow “preposition stranding” in examples such as (162b), provided at least that apparent preposition stranding results from the deletion of the resumptive pronominal part of the discontinuous PP *daar ... op*.

- (162) a. %*Regent het morgen, [~~dan~~ ga ik naar de bioscoop].*  
 rains it tomorrow then go I to the cinema  
 ‘If it rains, then I’ll go to the cinema.’  
 b. %*Bananen, [~~daar~~ ben ik dol op].*  
 bananas there am I fond of  
 ‘Bananas, I’m fond of (them).’

Since we are not able to test whether this expectation is borne out, we have to leave this to future research, while noting that we believe that a correlation is likely to be found. The reason for this optimism is that according to Van der Horst & Van der Horst (1999:270) the rise in popularity of the two constructions in (162) occurred more or less simultaneously (in the second half of the 20<sup>th</sup> century). Whatever the outcome of such an investigation, we can conclude from the discussion above that it is not at all obvious that the occurrence of conditional V1-clauses without resumptive *dan* refutes the hypothesis that V1-clauses do not occur clause-internally: an appeal to hypercorrection or an analysis such as (162a) would be completely consistent with this hypothesis.

Adverbial-like V1-clauses containing the modal verbs *willen* and *mogen* constitute a second potential problem. We will confine the discussion to cases with *willen*, as illustrated in (163). At first sight, these examples seem to be regular conditional constructions of the type discussed in subsection I: the optionality of the resumptive element *dan* ‘then’ in (163a) suggests that the *als*-clause is a run-of-the-mill adverbial clause, which can either occupy the clause-initial position of the main clause or be left-dislocated; the obligatoriness of *dan* in (163b) further suggests that we are dealing with a proper V1-clause in the sense that it occurs clause-externally.

- (163) a. *Als je wil slagen (dan) moet je harder werken.*  
 if you want pass.the.exam then come you harder work  
 ‘If you want to pass the exam, (then) you must work harder.’  
 b. *Wil je slagen \*(dan) moet je harder werken.*  
 want you pass.the.exam then come you harder work  
 ‘If you want to pass the exam, (then) you must work harder.’

Closer scrutiny shows, however, that in at least some cases we may be dealing with a slightly different construction type. First, the examples in (164) show that the alternation between the *als*-clause and the V1-clause is not always possible.

- (164) a. ??*Als het project wil slagen, (dan) moeten we hard werken.*  
 if the project wants succeed then must we hard work  
 b. *Wil het project slagen, \*(dan) moeten we hard werken.*  
 wants the project succeed then must we hard work  
 ‘We must work hard if the project is to succeed.’

Second, example (164b) does not express a °material implication: the °eventuality of “the project becoming a success” as expressed in the first clause is not presented as a sufficient condition for the eventuality of “we working hard” as expressed in the second clause. In fact, the relation is reversed: the second eventuality can be seen as a prerequisite for the first one to come into existence; Boogaart et al. (2007:240) characterize examples such as (164b) as teleological in nature. Related to this is that the modal verb *willen* in (164) cannot have a deontic (volitional) interpretation but is instead interpreted epistemically; cf. Section 5.2.3.2, sub IIIA. The primed examples in (165) show that teleological V1-clauses differ from the conditional ones in that they can occur in clause-final position.

- (165) a. *Regent het morgen, dan ga ik naar de bioscoop.*  
 rains it tomorrow then go I to the cinema  
 ‘If it rains tomorrow, then I’ll go to the cinema.’
- a’. \**Ik ga naar de bioscoop, regent het morgen.*  
 I go to the cinema rains it tomorrow
- b. *Wil het project slagen, dan moeten we hard werken.*  
 wants the project succeed then must we hard work  
 ‘If the project is to succeed, we must work hard.’
- b’. *We moeten hard werken, wil het project slagen.*  
 we must hard work wants the project succeed  
 ‘We must work hard if the project is to succeed.’

Since we have assumed that clause-final adverbial clauses are placed clause-internally, example (165b) is a potential counterexample to our hypothesis that V1-clauses can only occur clause-externally. A possible solution can be found in Beekhuizen (2008:46), where it is suggested that V1-clauses in examples such as (165b) are in fact parenthetical clauses. There are indeed reasons for assuming that this is the case: Subsection I has shown that parenthetical clauses have the characteristic property that they can contain *tenminste* ‘at least’ and this option is also available for clause-final teleological V1-clauses. Observe the contrast between the two examples in (166), which seems to show that a clause cannot simultaneously be left-dislocated and parenthetical in nature. For completeness’ sake, we have added example (165c) to show that the parenthetical clause can also appear in the middle field of the clause.

- (166) a. *Wil het project \*(tenminste) slagen, dan moeten we hard werken.*  
 wants the project at.least succeed then must we hard work  
 ‘For the project to succeed, we must work hard.’
- b. *We moeten hard werken, wil het project tenminste slagen.*  
 we must hard work wants the project at.least succeed  
 ‘We must work hard in order for the project to succeed.’
- c. *We moeten, wil het project tenminste slagen, hard werken.*  
 we must wants the project at.least succeed hard work  
 ‘We must work hard in order for the project to succeed.’

The presence of *dan* proves that the V1-clause in (166a) is clause-external and the possibility of *tenminste* in (166a) makes it plausible that we are dealing with a

parenthetical clause, and these two facts, in turn, strongly suggest that teleological V1-clauses conform to our hypothesis that adverbial-like V1-clauses occur clause-externally only. But, of course, more investigation of this construction is needed to establish this conclusion more firmly; we refer the reader to Beekhuizen (2008:ch.5) for a good starting point.

#### VI. Conclusion

Subsections I to IV have shown that the italicized V1/2-clauses in (123), repeated here as (167), are clause-external; in the conditional construction in (167a), this is clear from the fact that most speakers require the expression of the resumptive element *dan* ‘then’ in the initial position of the main clause; in the contrastive and concessive constructions in (167b&d), this is clear from the fact that the initial position of the main clause is occupied by some other constituent. For the exclamative construction in (167c), this is a bit harder to show but a juxtaposition analysis is quite plausible given that the first clause may also be used as the first conjunct in the near-synonymous coordinate construction *Helpt Marie iemand en dan wordt ze door hem beroofd!* ‘Imagine: Marie is helping someone and then that person robs her!’.

- (167) a. *Is Els morgen ziek*, dan gaat ze niet werken. [conditional V1]  
 is Els tomorrow ill then goes she not work  
 ‘If Els is ill again tomorrow, then she won’t go to work.’
- b. *Was Jan erg tevreden*, Peter was dat zeker niet. [contrastive V1]  
 was Jan very satisfied Peter was that certainly not  
 ‘Whereas Jan was very satisfied, Jan certainly wasn’t.’
- c. *Helpt Marie iemand*, wordt ze door hem beroofd! [exclamative V1]  
 helps Marie someone be she by him robbed  
 ‘Imagine: Marie is helping someone and that person robs her!’
- d. *Ook al is Els ziek*, toch gaat ze vandaag werken. [concessive V2]  
 even though is Els ill still goes she today work  
 ‘Even though Els is ill, she’s still going to work today.’

The discussion supported the hypothesis that verb-first/second is impossible in run-of-the-mill, that is, clause-internal adverbial clauses. Subsection V concluded with a number of potential problems for this hypothesis; it seems plausible, however, that the V1-clauses discussed in this subsection are not clause-internal either.

# Chapter 11 Word order in the clause III: Clause-initial position (*wh*-movement)

<b>Introduction</b>	<b>1316</b>
<b>11.1. The formation of V1- and V2-clauses</b>	<b>1317</b>
<b>11.2. Clause-initial position remains (phonetically) empty</b>	<b>1326</b>
11.2.1. <i>Yes/no questions</i>	1327
11.2.2. <i>Topic drop</i>	1329
11.2.3. <i>Finite imperatives</i>	1334
11.2.4. <i>Narrative inversion</i>	1344
11.2.5. <i>Other cases</i>	1345
<b>11.3. Clause-initial position is filled</b>	<b>1347</b>
11.3.1. <i>Wh-questions</i>	1349
11.3.1.1. <i>Wh-movement in simplex clauses (short wh-movement)</i>	1351
11.3.1.2. <i>Wh-extraction from embedded clauses (long wh-movement)</i>	1384
11.3.1.3. <i>Islands for question formation</i>	1397
11.3.1.4. <i>Multiple wh-questions</i>	1405
11.3.2. <i>Relative clauses</i>	1416
11.3.3. <i>Topicalization</i>	1422
11.3.4. <i>Wh-exclamatives</i>	1459
11.3.5. <i>Comparative (sub)deletion</i>	1486
11.3.6. <i>Reconstruction</i>	1493
11.3.7. <i>Parasitic gaps</i>	1509



**Introduction**

This chapter takes as its point of departure the discussion in 9.2, which has shown that finite verbs can be found in basically two positions: the clause-final position in embedded clauses and the verb-first/second position in main clauses; the latter position is normally occupied by a complementizer in embedded clauses.

- (1) a. Marie zegt [dat Jan het boek op dit moment *leest*].  
 Marie says that Jan the book at this moment reads  
 ‘Marie says that Jan is reading the book at this moment.’
- b. Op dit moment *leest* Jan het boek.  
 at this moment reads Jan the book  
 ‘At this moment, Jan is reading the book.’

On the basis of these two positions, the clause can be divided into various “topological” fields: the clause-initial position, the middle field and the postverbal field; cf. representation (2).

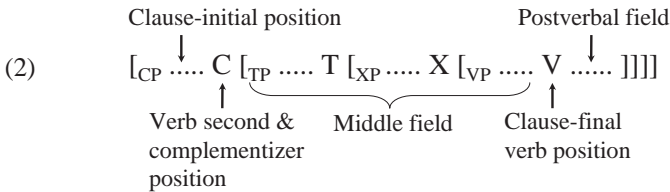

Like the C(omplementizer) position, T(ense) stands for a functional head that may in principle host the finite verb, and there may be more of such positions in the clause, which we have indicated by X. Section 9.1 has argued that languages may differ in the placement of the finite verb: C, T or some other head X. This is irrelevant for our present discussion but we will see that there are reasons for assuming that in subject-initial main clauses the verb is not situated in C but in T.

This chapter discusses the clause-initial position, that is, the unique position left-adjacent to the finite verb in main clauses or the complementizer in embedded clauses. The examples in (3) show that this position may be empty, as in the *yes/no*-questions in the (a)-examples, or be filled by some constituent, like the adverbial phrase *hoe laat* ‘at what time’ in the *wh*-questions in the (b)-examples.

- (3) a. Is Peter morgen hier? [yes/no-question]  
 is Peter tomorrow here  
 ‘Will Peter be here tomorrow?’
- a'. Ik weet niet [of Peter hier is].  
 I know not if Peter here is  
 ‘I don’t know whether Peter will be here tomorrow.’
- b. Hoe laat is Peter hier? [wh-question]  
 how late is Peter here  
 ‘At what time will Peter be here?’
- b'. Ik weet niet [hoe laat (of) Peter hier is].  
 I know not how late if Peter here is  
 ‘I don’t know at what time Peter will be here.’

Verb-first sentences, that is, main clauses with the finite verb in first position, are not always *yes/no*-questions but come in various types; this will be discussed in Section 11.2. Verb-second sentences, that is, main clauses with the verb in second position, also show up in various types, this will be discussed in Section 11.3. Section 11.1 starts by providing a more general introduction to the movement operations involved in the formation of verb-first and verb-second clauses.

### 11.1. The formation of V1- and V2-clauses

This section discusses some general issues related to the clause-initial position. Subsection I starts with a review of the operation that moves the finite verb from its clause-final position into the C-position in the left-periphery of the clause; see Chapter 10 for a more extensive discussion. Verb movement results in verb-first (henceforth: V1) structures and Subsection II will demonstrate how verb-second (henceforth: V2) clauses can be derived by subsequent topicalization or question formation. Subsection III will show that the clause-initial position can be filled by at most one constituent. Subsection IV will show that there are no constraints on the syntactic function of the constituent occupying the clause-initial position; it seems that virtually any clausal constituent can occupy this position. This is related to the fact, discussed in Subsection V, that the clause-initial constituent normally has a specific information-structural function. Subject-initial main clauses are exceptional in this respect but Subsection VI will show that there are more reasons to set such cases apart. Subsection VII concludes by showing that main and embedded clauses exhibit different behavior with respect to their initial position: for example, while the initial position of declarative main clauses is normally filled by the subject or some topicalized element, the initial position of declarative embedded clauses is normally empty.

#### I. Verb movement: Verb-first/second

Since Paardekooper (1961) it has normally been assumed that complementizers in embedded clauses and finite verbs in main clauses occupy the same structural position in the clause. In the traditional version of generative grammar this is derived as depicted in (4). In embedded clauses, the complementizer *dat* ‘that’ or *of* ‘if’ must be inserted in the C(omplementizer)-position. In main clauses, the finite verb is moved into this position from its original VP-internal position via the intermediate T(ense)-position; note that, for theoretical reasons, it is normally also assumed that the finite verb also moves through all intermediate X-positions, but this is not depicted here. Verb-movement is blocked in embedded clauses because complementizer insertion is obligatory in this context and thus occupies the target position of the finite verb. The obligatoriness of verb-movement in main clauses follows if we assume that the C-position must be filled but that complementizer insertion is restricted to embedded clauses.

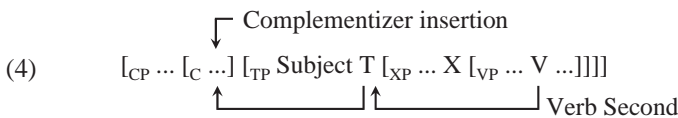

The claim that complementizers in embedded clauses and finite verbs in main clauses are placed in the C-position is empirically motivated by Paardekooper's observation that they display similar placement with respect to referential subject pronouns like *zij* 'she'. Putting subject-initial main clauses aside for the moment, the examples in (5) show that such pronouns are always right-adjacent to the finite verb in main clauses or right-adjacent to the complementizer in embedded clauses.

- (5) a. Gisteren *was zij* voor zaken in Utrecht. [main clause]  
 yesterday was she on business in Utrecht  
 'Yesterday she was in Utrecht on business.'  
 a'. \*Gisteren *was* voor zaken *zij* in Utrecht.  
 b. Ik dacht [*dat zij* voor zaken in Utrecht was]. [embedded clause]  
 I thought that she on business in Utrecht was  
 'I thought that she was in Utrecht on business.'  
 b'. \*Ik dacht *dat* voor zaken *zij* in Utrecht was.

This observation can be derived immediately if we assume that subject pronouns obligatorily occupy the regular subject position, that is, the specifier position of TP, which is indicated by "Subject" in representation (4).

## II. Topicalization and question formation

The derivation of V1 and V2-clauses is now very straightforward and simple. The clause-initial position can be identified with the specifier position of CP, indicated in (4) by the dots preceding the C-position. V1-clauses arise if this position remains empty, while V2-clauses arise if this position is filled by some constituent. Prototypical cases of V1-clauses are *yes/no*-questions such as (6a); whether the clause-initial position is truly empty or filled by some phonetically empty question operator is difficult to establish; we will postpone this issue to Section 11.2.1. V2-clauses arise if some constituent is moved into the specifier position of CP, that is, the clause-initial position: the movement operation involved is used to derive various different kinds of constructions like the topicalization construction in (6b) and the *wh*-question in (6c); the  $\circ$ traces indicate the original position of the moved phrase.

- (6) a. Heeft Jan dat boek met plezier gelezen? [V1; *yes/no*-question]  
 has Jan that book with pleasure read  
 'Has Jan enjoyed reading that book?'  
 b. Dat boek<sub>i</sub> heeft Jan  $t_i$  met plezier gelezen. [V2; topicalization]  
 that book has Jan with pleasure read  
 'That book, Jan has enjoyed reading.'  
 c. Welk boek<sub>i</sub> heeft Jan  $t_i$  met plezier gelezen? [V2; *wh*-question]  
 what book has Jan with pleasure read  
 'Which book has Jan enjoyed reading?'

## III. The clause-initial position contains at most one constituent

Consider again the representation in (4), repeated below as (7). Functional elements like T and C are generally assumed to contain certain semantic and morphosyntactic features. The functional element T(ense), for example, is normally assumed to contain the feature [ $\pm$ FINITE]; this verbal feature is what enables the movement of the finite verb into T, as depicted in representation (7). A positive value for this

feature enables T to assign nominative case to the subject of the clause, and it is assumed that this morphosyntactic relation between T and the subject enables the latter to be moved into the specifier position of T; we refer the reader to Section 9.5 for arguments showing that the subject is base-generated in a VP-internal position.

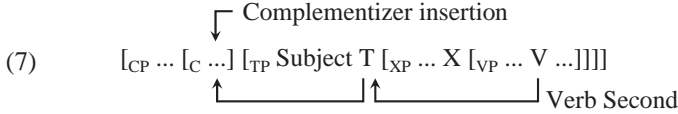

For our present discussion it is important to emphasize that the relation between the T-head and the subject is unique: a finite clause has (at most) one nominative argument. In the active clause in (8a) nominative case is assigned to *Peter/hij* and in the passive clause in (8b) it is assigned to *Marie/zij*, but there are no clauses with two nominative nominal arguments: \**Hij bezocht zij* ‘\*He visited she’.

- (8) a. Peter/Hij heeft gisteren Marie/haar bezocht.  
 Peter/he has yesterday Marie/her visited  
 ‘Pete/He visited Marie/her yesterday.’
- b. Marie/zij werd gisteren door Peter/hem bezocht.  
 Marie/she was yesterday by Peter/him visited  
 ‘Marie/she was visited by Peter/him yesterday.’

It is often assumed that the element C has features related to the illocutionary force of the clause: the feature  $[\pm Q]$ , for example, may determine whether we are dealing with a declarative or an interrogative clause. Contrary to  $[\pm \text{FINITE}]$ , the feature  $[\pm Q]$  has no overt morphological manifestation on the verb in Dutch but it does affect the morphological form of the complementizer: the feature  $[-Q]$  requires it to be spelled-out as *dat* ‘that’ while  $[+Q]$  requires it to be spelled-out as *of* ‘if’.

- (9) a. Marie zegt  $[_{CP} \text{ dat}_{[-Q]}$  Peter het boek met plezier gelezen heeft].  
 Marie says that Peter the book with pleasure read has  
 ‘Marie says that Peter has enjoyed reading the book the book.’
- b. Marie vraagt  $[_{CP} \text{ of}_{[+Q]}$  Peter het boek met plezier gelezen heeft].  
 Marie asks if Peter the book with pleasure read has  
 ‘Marie is asking whether Peter has enjoyed reading the book the book.’

The examples in (10) show that the value of the feature  $[\pm Q]$  also determines what element may occupy the specifier position of CP in main clauses: while the (a)-examples show that it is possible to topicalize the direct object *het boek* or the indirect object *aan Marie* in the declarative clauses, the (b)- and (c)-examples show that topicalization is excluded in interrogative clauses; the feature  $[+Q]$  only allows the specifier of CP to be filled by a *wh*-phrase. Note that (10b’&c’) are (marginally) acceptable as °echo-questions but this is of course not the reading intended here.

- (10) a. Dit boek<sub>i</sub> heeft Peter t<sub>i</sub> aan Marie aangeboden.  
 this book has Peter to Marie prt.-offered  
 ‘This book, Peter has offered to Marie.’
- a’. Aan Marie<sub>i</sub> heeft Peter dit boek t<sub>i</sub> aangeboden.  
 to Marie has Peter this book prt.-offered  
 ‘To Marie, Peter has offered this book.’

- b. Welk boek<sub>i</sub> heeft Peter t<sub>i</sub> aan Marie aangeboden?  
 which book has Peter to Marie prt.-offered  
 ‘Which book has Peter offered to Marie?’
- b’. \*Aan Marie<sub>i</sub> heeft Peter welk boek t<sub>i</sub> aangeboden?  
 to Marie has Peter which book prt.-offered
- c. Aan wie heeft Peter dit boek t<sub>i</sub> aangeboden?  
 to who has Peter this book prt.-offered  
 ‘To whom has Peter offered this book?’
- c’. \*Dit boek heeft Peter t<sub>i</sub> aan wie aangeboden?  
 this book has Peter to who prt.-offered

The examples in (11) further show that the specifier position of CP can contain at most one constituent; it is impossible to move more than one constituent into the clause-initial position. First, although the (a)-examples in (10) have shown that the direct and the indirect object can both be topicalized, example (11a) shows that they cannot be topicalized simultaneously. Second, although example (11b) shows that a clause may contain more than one *wh*-phrase, example (11b’) shows that it is not possible to place more than one *wh*-phrase in its clause-initial position.

- (11) a. \*Dit boek<sub>i</sub> aan Marie<sub>j</sub> heeft Jan t<sub>i</sub> t<sub>j</sub> aangeboden.  
 this book to Marie has Jan prt.-offered
- b. Welk boek<sub>i</sub> heeft Jan t<sub>i</sub> aan wie aangeboden?  
 which book has Jan to who prt.-offered  
 ‘Which book did Jan offer to whom?’
- b’. \*Welk boek<sub>i</sub> aan wie<sub>j</sub> heeft t<sub>i</sub> t<sub>j</sub> Jan aangeboden?  
 which book to who has Jan prt.-offered

The examples in (10) and (11) show that the specifier position of CP resembles the specifier position of T in that it can be filled by at most one constituent which is compatible with its feature specification: like the specifier of T<sub>[+finite]</sub> can only be occupied by a nominative argument, the specifier of C<sub>[+Q]</sub> can only be occupied by a *wh*-phrase. Note that the C-feature [+Q] postulated in this subsection may be part of a larger set of features, as the constituents in clause-initial position may have a variety of special semantic functions; we return to this in Section 11.3.

#### *IV. The syntactic function of the constituent in clause-initial position*

The fact illustrated in (11) that the clause-initial position may contain at most one constituent underlies the standard Dutch °constituency test: anything that may occur in clause-initial position can be analyzed as a constituent. The utility of this test is based on the fact that virtually all clausal constituents can occupy this position. The examples in (12), for instance, show that topicalization and question formation affect arguments and adverbial phrases alike.

- (12) a. Jan zal morgen dat boek lezen.  
 Jan will tomorrow that book read  
 ‘Jan will read that book tomorrow.’
- b. Dat boek<sub>i</sub> zal Jan morgen t<sub>i</sub> lezen. [object]  
 that book will Jan tomorrow read  
 ‘That book, Jan will read tomorrow.’

- b'. Wat<sub>i</sub> zal Jan morgen t<sub>i</sub> lezen?  
 what will Jan tomorrow read  
 'What will Jan read tomorrow?'
- c. Morgen<sub>i</sub> zal Jan t<sub>i</sub> dat boek lezen. [adverbial phrase]  
 tomorrow will Jan that book read  
 'Tomorrow Jan will read that book.'
- c'. Wanneer<sub>i</sub> zal Jan t<sub>i</sub> dat boek lezen?  
 when will Jan that book read  
 'When will Jan read that book?'

The examples in (13) show that °complementives can also be placed in clause-initial position. For the sake of brevity, (13) illustrates this for *wh*-questions only, but similar examples are common in topicalization constructions as well; cf., e.g., *Boven mijn bed hang ik jouw schilderij* 'Over my bed, I will hang your painting.'

- (13) a. Ik wil dierenarts worden. Wat<sub>i</sub> wil jij t<sub>i</sub> worden?  
 I want vet become what want you become  
 'I want to be a vet. What do you want to be?'
- b. Ik vond de film saai. Hoe<sub>i</sub> vond jij hem t<sub>i</sub>?  
 I found the movie boring. how found you him  
 'I thought the movie boring. What did you think of it?'
- b'. Ik hang jouw schilderij boven mijn bed. Waar<sub>i</sub> hang jij het mijne t<sub>i</sub>?  
 I hang your painting above my bed where hang you the mine  
 'I'll hang your painting over my bed. Where will you hang mine?'

It should be noted however, that the clause-initial position is not only accessible to clausal constituents, but may sometimes also contain *parts* of clausal constituents. This is illustrated in the (a)-examples in (14) for so-called R-extraction: although the primeless example shows that prepositional objects are normally *wh*-moved as a whole, the primed example shows that they can easily be split if they have the pronominalized form *waar*+P; see Section P5 for extensive discussion. Example (14b) shows the same for so-called *wat voor*-phrases; cf. N4.2.2.

- (14) a. <Naar> wie zoek je <\*naar>?  
 for who look you  
 'Who are you looking for?'
- a'. Waar <naar> zoek je <naar>?  
 where for look you  
 'What are you looking for?'
- b. Wat <voor een boek> wil je <voor een boek> lezen?  
 what for a book want you read  
 'What kind of a book do you want to read?'

We must therefore be aware not to jump to the conclusion that we are dealing with a clausal constituent if a certain string of words occurs in clause-initial position: all we can conclude is that we are dealing with a constituent, which may be a clausal constituent but which may also be a subpart of clausal constituent.

*V. Clause-initial constituents are semantically marked*

The previous subsection has shown that there are no syntactic restrictions on the constituent in clause-initial position, that is, the specifier position of CP; in principle any clausal constituent may be placed in this position. In this respect, the specifier position of CP is of an entirely different nature than the specifier of TP, which is a designated position of the subject. The movements involved in filling these specifiers are therefore also of an entirely different nature, which is sometimes expressed by saying that there is a distinction between A- and A'-movement. A(argument)-movement is restricted to the nominal arguments, that is, subjects and direct/indirect objects. These movements are triggered by morphosyntactic features like [ $\pm$ FINITE] or [ $\pm$ AGREEMENT], which play a role in syntactic relations like structural  $\circ$ case (nominative, accusative and dative) assignment and subject/object-verb agreement. A'-movements are not restricted to nominal arguments and are not triggered by morphosyntactic but by semantic features. Features that may play a role in topicalization constructions are the features [ $\pm$ TOPIC] and [ $\pm$ FOCUS]. The feature [+TOPIC] introduces the clause-initial constituent as the active discourse topic. An example such as (15a) introduces the referent of the direct object as a (new) discourse topic and it is consequently likely that in a follow-up sentence more information will be provided about this referent. The feature [ $\pm$ FOCUS] marks the clause-initial constituent as noteworthy in some sense, which is emphasized by the fact that this constituent is normally assigned extra accent (indicated here by small caps). Example (15b), for example, contrasts the referent of the clause-initial constituent with other entities in a contextually given set.

- (15) a. Peter<sub>i</sub> heb ik nog niet  $t_i$  gesproken. Hij is nog op vakantie.  
 Peter have I not yet spoken he is still on vacation  
 'As for Peter, I haven't spoken to him yet. He's still on vacation.'
- b. PETER<sub>i</sub> heb ik nog niet  $t_i$  gesproken (maar de ANDEREN wel).  
 Peter have I not yet spoken but the others AFF  
 'Peter, I haven't spoken to yet, but I did speak to the others.'

The fact that topicalization does not occur in embedded clauses suggests that the features [ $\pm$ TOPIC] and [ $\pm$ FOCUS] can be found on the C-heads of main clauses only. This does not hold for the feature [ $\pm$ Q] that we find on the C-heads of interrogative clauses, as is clear from the fact illustrated in (16) that such clauses can also be embedded.

- (16) a. Ik weet niet [<sub>CP</sub> of<sub>[+Q]</sub> ik dit boek zal lezen].  
 I know not if I this book will read  
 'I don't know if I'll read this book.'
- b. Ik weet niet [<sub>CP</sub> welk boek (of<sub>[+Q]</sub>) ik  $t_i$  zal lezen].  
 I know not which book if I will read  
 'I don't know which book I'll read.'

Observe that the interrogative complementizer *of* 'if' is optional in examples such as (16b), which is related to the fact that there is a certain preference for not pronouncing the complementizer if the clause-initial position is filled. This phenomenon is also found in other languages; see, e.g., Chomsky & Lasnik (1977),



who account for this by means of the so-called *doubly-filled-comp filter*, and Pesetsky (1997/1998), who provides an account in terms of optimality theory.

There are also features like [ $\pm$ RELATIVE] that occur in embedded clauses only. This feature creates relative clauses and can be held responsible for the movement of relative pronouns into clause-initial position. The percentage signs in the examples in (17) express that the complementizer *dat*<sub>[+REL]</sub> is normally not pronounced in Standard Dutch but that it was possible in Middle Dutch and is still possible in various present-day Dutch dialects; see, e.g., Pauwels (1958), Dekkers (1999:ch.3) and references cited there.

- (17) a. de brief [<sub>CP</sub> die<sub>i</sub> (%*dat*<sub>[+REL]</sub>) ik gisteren *t*<sub>i</sub> ontvangen heb].  
 the letter which that I yesterday received have  
 ‘the letter which I received yesterday’  
 b. de plaats [<sub>CP</sub> waar<sub>i</sub> (%*dat*<sub>[+REL]</sub>) ik ga *t*<sub>i</sub> slapen]  
 the place where that I go sleep  
 ‘the place where I’m going to sleep’

VI. *Subject-initial sentences are special*

The previous subsection has shown that clause-initial constituents normally play a specific information-structural role (*wh*-phrase, topic, focus, etc.) in the clause. This was confirmed by the results of a recent corpus-study: “Non-subject material in the Vorfeld (= clause-initial position) is characterized by its (relative) importance.” (Bouma 2008). The reason for providing this quote is that Bouma also found that this general characterization does not extend to subject-initial clauses: these are special in that they are normally the most unmarked way of asserting a proposition. That subject-initial clauses are unmarked is clear from the fact that they are generally used if the full sentence consists of new information: the word order in example (18a) is the one we typically get as an answer to the question *Wat is er gebeurd?* ‘What has happened?’. This raises the question as to whether subject-initial main clauses have the same overall structure as other V2-constructions, as is assumed in the more traditional versions of generative grammar where an example such as (18a) is derived as in (18a).

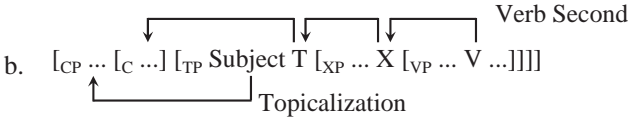
- (18) a. Marie heeft haar boek verkocht.  
 Marie has her book sold  
 ‘Marie has sold her book.’  
 b. [<sub>CP</sub> ... [<sub>C</sub> ...] [<sub>TP</sub> Subject T [<sub>XP</sub> ... X [<sub>VP</sub> ... V ...]]]]  

If the movement into the specifier of CP is indeed motivated by some semantic feature, the fact that (18a) is the unmarked way of expressing the proposition HAVE READ(Marie,this book) would be quite surprising. Furthermore, Section 9.3 has shown that there are various other conspicuous differences between clause-initial subjects and other topicalized phrases. The most conspicuous difference is that the former can be a phonetically reduced pronoun, but the latter cannot. Consider the examples in (19). The primeless examples show that the subject can be clause-initial regardless of its form: it can be a full noun phrase like *Marie*, a full pronoun like *zij*



or a phonetically reduced pronoun like *ze*. The primed examples show that topicalized objects are different: topicalization is possible if it has the form of a full noun phrase like *Peter* or a full pronoun like *hem*, but not if it has the form of the weak (phonetically reduced) pronoun *'m*. The reason for this is that while topicalized objects must be accented (which is indicated by means of small caps) clause-initial subjects can remain unstressed.

- (19) a. Marie helpt Peter/hem/'m.      a'. PETER helpt Marie/zij/ze.  
 Marie helps Peter/him/him      Peter helps Marie/she/she  
 'Marie is helping Peter/him.'      'Peter, Marie/she is helping.'
- b. Zij helpt Peter/hem/'m      b'. HEM helpt Marie/zij/ze.  
 she helps Peter/him/him.      him helps Marie/she/she  
 'She's helping Peter/him.'      'Him, Marie/she is helping.'
- c. Ze helpt Peter/hem/'m      c'. \*'M helpt Marie/zij/ze.  
 she helps Peter/him/him.      him helps Marie/she/she  
 'She's helping Peter/him.'

That topicalized phrases must be accented can also be illustrated by the examples in (20). The (a)-examples show that while the adverbial pro-form *daar* 'there' can readily be topicalized, the phonetically reduced form *er* cannot. The (b)-examples illustrate the same thing for cases in which these elements function as the nominal part of a pronominal PP.

- (20) a. Jan heeft daar/er      gewandeld.  
 Jan has there/there walked  
 'Jan has walked there.'
- a'. Daar/\*Er heeft Jan gewandeld.  
 there/there has Jan walked
- b. Jan heeft daar/er mee gespeeld.  
 Jan has there/there with played  
 'Jan has played with that/it.'
- b'. Daar/\*Er heeft Jan mee gespeeld.'  
 there/there has Jan with played

We can readily account for these differences between subject-initial main clauses and other types of V2-clauses if we assume that these have the two different representations in (21): if sentence-initial subjects are not topicalized, there is no reason to expect that such constructions give rise to a marked interpretation or require a special intonation pattern.

- (21) a. • Subject-initial main clause
- 
- b. • Topicalization and question formation in main clause
-

Accepting the two structures in (21) would also make it possible to account for the contrast in verbal inflection in the examples in (22) by making the form of the finite verb sensitive to the position it occupies; if the verb is in T, as in (22a), second person singular agreement is realized by means of a *-t* ending, but when it is in C, as in (22b&c), it is realized by means of a null morpheme.

- (22) a. Jij/Je loop-t niet erg snel.  
 you/you walk-2sg not very fast  
 ‘You don’t walk very fast.’  
 b. Erg snel loop-Ø jij/je niet.  
 very fast walk-2sg you/you not  
 ‘You don’t walk very fast.’  
 c. Hoe snel loop-Ø jij/je?  
 how fast walk-2sg you/you  
 ‘How fast do you walk?’

The discussion above thus shows that there are good reasons not to follow the traditional generative view that Dutch main clauses are always CPs; subject-initial main clauses may be special in that they are TPs. This hypothesis may help us to account for the following facts: (i) subject-initial clauses are unmarked assertions, (ii) sentence-initial subjects can be a reduced pronoun and (iii) subject-verb agreement may be sensitive to the position of the subject.

### VII. Main versus embedded clauses

There is a conspicuous difference between the clause-initial positions of main and embedded finite declarative clauses: the examples in (23) show that while the former are normally filled by the subject or some topicalized phrase, the latter are normally empty.

- (23) a. Jan heeft *Vaslav* van Arthur Japin gelezen.  
 Jan has *Vaslav* by Arthur Japin read  
 ‘Jan has read *Vaslav* by Arthur Japin.’  
 a'. *Vaslav* van Arthur Japin heeft Jan gelezen.  
*Vaslav* by Arthur Japin has Jan read  
 ‘*Vaslav* by Arthur Japin Jan has read.’  
 a''. \*Ø heeft Jan *Vaslav* van Arthur Japin gelezen.  
 has Jan *Vaslav* by Arthur Japin read  
 b. Ik denk [<sub>CP</sub> Ø dat [<sub>TP</sub> Jan *Vaslav* van Arthur Japin gelezen heeft]].  
 I think that Jan *Vaslav* by Arthur Japin read has  
 ‘I think that Jan has read *Vaslav* by Arthur Japin.’  
 b'. \*Ik denk [<sub>CP</sub> Jan<sub>i</sub> (dat) [<sub>TP</sub> t<sub>i</sub> *Vaslav* van Arthur Japin gelezen heeft]].  
 I think Jan that *Vaslav* by Arthur Japin read has  
 b''. \*Ik denk [<sub>CP</sub> *Vaslav* van Arthur Japin<sub>i</sub> (dat) [<sub>TP</sub> Jan t<sub>i</sub> gelezen heeft]].  
 I think *Vaslav* by Arthur Japin that Jan read has

Observe that we placed the complementizers in the primed (b)-examples within parentheses because we have seen that the phonetic content of a complementizer is often omitted if the specifier of CP is filled by phonetic material; see the discussion of the *doubly-filled-comp filter* in Subsection V.

Such a difference between finite main and dependent clauses does not arise in the case of interrogative clauses. The examples in (24) show that the initial position is phonetically empty in *yes/no*-questions but filled by some *wh*-phrase both in main and in embedded clauses.

- (24) a.  $\emptyset$  Heeft Jan *Vaslav* van Arthur Japin gelezen?  
           has Jan *Vaslav* by Arthur Japin read  
           ‘Has Jan read *Vaslav* by Arthur Japin?’  
 a’. Wat<sub>i</sub> heeft Jan t<sub>i</sub> gelezen?  
       what has Jan read  
       ‘What has Jan read?’  
 b. Ik weet niet [<sub>CP</sub>  $\emptyset$  of [<sub>TP</sub> Jan *Vaslav* van Arthur Japin gelezen heeft]].  
       I know not  $\emptyset$  if Jan *Vaslav* by Arthur Japin read has  
       ‘I don’t know whether Jan has read *Vaslav* by Arthur Japin.’  
 b’. Ik weet niet [<sub>CP</sub> wat<sub>i</sub> (of) [<sub>TP</sub> Jan t<sub>i</sub> gelezen heeft]].  
       I know not what if Jan read has  
       ‘I don’t know what Jan has read.’

Finite main and embedded clauses do differ in that only the latter can be used as relative clauses. The examples in (25) show that such clauses require some relative element to be placed in clause-initial position; we already mentioned in Subsection V that the complementizer *dat* is normally omitted in Standard Dutch relative clauses.

- (25) a. Dit is de roman [<sub>CP</sub> die<sub>i</sub> (\*dat) [<sub>TP</sub> Jan t<sub>i</sub> gelezen heeft]].  
           this is the novel REL that Jan read has  
           ‘This is the novel that Jan has read.’  
 b. \*Dit is de roman [<sub>CP</sub>  $\emptyset$  (dat) [<sub>TP</sub> Jan die gelezen heeft]].  
           this is the novel that Jan REL read has

The initial position of infinitival clauses is normally phonetically empty. Examples such as (26a) are possible but seem to be of an idiomatic nature in colloquial speech; cf. Section 4.2. Note that the complementizer must be empty in these examples, and that PRO stands for the phonetically empty subject of the infinitival clause. For examples such as (26b) it is sometimes assumed that the clause-initial position is filled by a phonetically empty °operator OP; we will not discuss such examples here but refer the reader to Section N3.3.3 for more information.

- (26) a. Ik weet niet [<sub>CP</sub> wat<sub>i</sub> [<sub>C</sub>  $\emptyset$ ] [<sub>TP</sub> PRO t<sub>i</sub> te doen]].  
           I know not what to do  
           ‘I don’t know what to do.’  
 b. Dat is een auto [<sub>CP</sub> OP<sub>i</sub> [<sub>C</sub> om] [<sub>TP</sub> PRO t<sub>i</sub> te zoenen]].  
           that is a car COMP to kiss  
           ‘That is a car to be delighted about/an absolutely delightful car.’

## 11.2. Clause-initial position remains (phonetically) empty

This section discusses clauses in which the clause-initial position in representation (27) remains empty. This results in V1-clauses (that is, main clauses with the finite verb in first position) and embedded clauses with a complementizer in first position. We refer the reader to Section 9.1 for a more detailed discussion of structure (27).

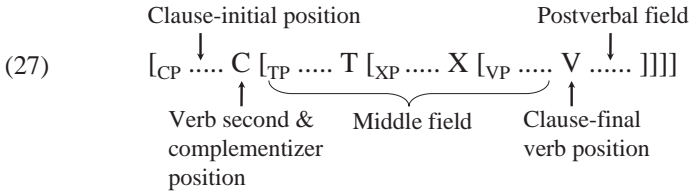

Section 11.1, sub VII, has shown that the clause-initial position of non-interrogative embedded clauses normally remains empty, so that there is not much to say about such cases; this section therefore focuses on V1-clauses. We will argue that at least some V1-clauses have a covertly filled initial position, that is, a clause-initial position filled by some constituent without a phonetic realization. This leads to the hypothesis that, from a syntactic perspective, there are no “true” V1-clauses but that the V1-order is merely a superficial *phonetic* phenomenon.

11.2.1. Yes/no questions

Polar (*yes/no*) questions are prototypical cases of Dutch V1-clauses. Although it is normally the V1-order that occurs in written texts, it is possible in speech to mark a polar question by means of a typical rising intonation; see, e.g., Haan (2002), Haan & Van Heuven (2003), Barbiers (2007:103), and references cited there.

- (28) a. Peter heeft dat boek gelezen. [declarative]  
 Peter has that book read  
 ‘Peter has read that book.’
- b. Heeft Peter dat boek gelezen? [polar V1-clause]  
 has Peter that book read  
 ‘Has Peter read that book?’
- c. Peter heeft dat boek gelezen? [polar V2-clause]  
 Peter has that book read  
 ‘Has Peter read that book?’



Polar V1-questions are normally less marked than polar V2-questions. The primeless examples in (29) are more neutral than the primed examples, which imply a certain expectation on the part of the speaker, or express (lack of) confidence in the truth of the proposition expressed by the clause; cf. Droste (1972). In other words, polar V2-questions have a similar function as the tag-questions in the English translations in the primed examples (which find their Dutch equivalent in the optional particle *hè*). We will ignore polar V2-clauses in what follows.

- (29) a. Ga je toch naar Amsterdam?  
 go you PRT to Amsterdam  
 ‘Are you going to Amsterdam after all?’
- a’. Je gaat toch naar Amsterdam (hè)?  
 you go PRT to Amsterdam PRT  
 ‘You’re going to Amsterdam after all, aren’t you?’
- b. Heb je dat boek toch gelezen?  
 have you that book PRT read  
 ‘Have you read that book after all?’
- b’. Je hebt dat boek toch gelezen (hè)?  
 you have that book PRT read PRT  
 ‘You have read that book after all, haven’t you?’

An important question is whether the clause-initial position in polar V1-clauses is truly empty or whether this position is occupied by some phonetically empty polarity operator: [<sub>CP</sub> OP<sub>polar</sub> heeft [<sub>TP</sub> Peter dat boek gelezen *t*<sub>heeft</sub>]]? The latter option is argued by Barbiers (2007/2013) on the basis of the left-dislocation examples in (30). The (a)-examples show that in declarative clauses °left dislocation is possible with a resumptive pronoun in the middle field or in the clause-initial position. The (b)-examples, on the other hand, show that the resumptive pronoun cannot occur in the clause-initial position in *yes/no*-questions.

- (30) a. Dat boek, Peter heeft het gelezen.  
 that book Peter has it read  
 ‘That book, Peter has read it.’  
 a'. Dat boek, heeft Peter het gelezen?  
 that book has Peter it read  
 ‘That book, has Peter read it?’  
 b. Dat boek<sub>i</sub>, dat heeft Peter *t*<sub>i</sub> gelezen.  
 that book that has Peter read  
 ‘That book, Peter has read that.’  
 b'. #Dat boek<sub>i</sub>, dat heeft Peter *t*<sub>i</sub> gelezen?  
 that book that has Peter read  
 ‘That book, has Peter read that?’

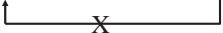
Assessing this argument is hampered by the fact, indicated by the number sign, that examples such as (30b') are acceptable if pronounced with the intonation contour typical of polar V2-clauses such as (28c), which is somewhat easier to get if we add the modal particle *toch*; *Dat boek, dat heeft Peter toch gelezen?* This means that we have the two structures in (31): the polar V1-construction in (31a) does not allow movement of the resumptive pronoun in clause-initial position given that this position is already occupied by the phonetically empty polar operator; the polar V2-construction in (31b) does allow movement.

- (31) a. Dat boek, [<sub>CP</sub> OP<sub>polar</sub> heeft [<sub>TP</sub> Peter dat gelezen *t*<sub>heeft</sub>]]?  
  
 b. Dat boek, [<sub>CP</sub> \_\_\_ heeft [<sub>TP</sub> Peter dat gelezen *t*<sub>heeft</sub>]]?  

Given that the grammatical and ungrammatical version of (30b') can only be distinguished on the basis of their intonation contour, it would be desirable if we could provide supplementary, independent evidence for the hypothesis that polar V1-structures have a phonetically empty operator in clause-initial position. Such evidence can be provided by the following constructions with the °negative polarity phrase *ook maar iets* ‘anything’. Example (32a) shows that such phrases cannot occur in positive declarative clauses: as their name expresses, they typically occur in the context of sentential negation, which is expressed in (32b) by the negation on the subject *niemand* ‘nobody’.

- (32) a. \*Jan heeft ook maar iets gelezen.  
 Jan has OOK MAAR something read  
 b. Niemand heeft ook maar iets gelezen.  
 nobody has OOK MAAR something read  
 ‘Nobody has read anything.’

It is not the case, however, that negative polarity *ook maar*-phrases are only licensed by a negative operator: example (33a) shows that they may also occur in polar questions. This can readily be explained if we assume that empty polar operators are also able to license *ook maar*-phrases. The fact that the corresponding polar V2-clause in (33b) does not allow an *ook maar*-phrase is consistent with Barbiers’ claim that such clauses are declarative and thus do not have an empty polar operator. For completeness’ sake, note that negation and the polar operator are just two specific cases of a larger set of so-called affective operators that license negative polarity items; we refer the reader to, e.g., Klima (1964), Progovac (1994) and Haegeman (1995:ch.2) for discussion.

- (33) a. Heeft Peter ook maar iets gelezen?  
 has Peter OOK MAAR something read  
 ‘Has Peter read anything?’  
 b. \*Peter heeft ook maar iets gelezen?  
 Peter has OOK MAAR something read

The discussion above has provided empirical support for the claim that polar V1-clauses have a phonetically empty polar operator in initial position and are thus only apparent exceptions to the claim that clause-initial positions of main clauses must be filled by some syntactic constituent.

### 11.2.2. Topic drop

The notions TOPIC and COMMENT are used in the semantic description of sentences: the topic of a sentence is the entity about which something is said, while the further statement made about this entity is the comment; cf. Crystal (1991). The topic-comment division may coincide with the subject-predicate division, but this is not necessarily the case. In the question-answer pair in (34), for instance, the topicalized object pronoun *die* ‘that’ refers to the topic. The term TOPIC DROP refers to the fact that such topics can be omitted if certain conditions are met. In (34), this results in a V1-structure; cf. Jansen (1981:ch.5). We will argue this to be a phonetic phenomenon: despite being not pronounced, the pronoun is syntactically present.

- (34) a. Weet jij waar Jan is?  
 know you where Jan is  
 ‘Do you know where Jan is?’  
 b. Nee, (*die*<sub>i</sub>) heb ik *t*<sub>i</sub> niet gezien?  
 no that have I not seen  
 ‘No, I haven’t seen him.’

Topic drop requires that the reference of the topic can be reconstructed from the context (which is known as the °recoverability condition); cf. Weerman (1989:53ff.). The examples in this section provide the reference in the preceding

question, but it may also be expressed in other ways. It should further be noted that Thrift (2003: Section 2.3) found that acceptability judgments made by speakers depend on the person features of the omitted topic; omission of arguments referring to (sets of individuals including) the speaker and, especially, the hearer are often judged to be unacceptable. Thrift suggests that this is due to the fact that the reference of first and second person pronouns shifts in conversation due to turn-taking, which may also account for the fact that first person pronouns are easily dropped in ego-documents and monologues, in which turn-taking does not play a role. The data in Jansen (1981) and Thrift (2003) further suggest that in speech topic drop is more frequent and considered more common with objects than with subjects.

Example (34b) has shown that topics can be topicalized and then occupy the sentence-initial position. The question-answer pairs in (35) show, however, that this is not obligatory: the topic may also occur in the middle field of the clause.

- (35) a. Ken jij *Het beleg van Laken* van Walter van den Broeck?  
 know you *Het beleg van Laken* by Walter van den Broeck  
 ‘Do you know *Het beleg van Laken* by Walter van den Broeck?’
- b. Ja, ik heb het/dat met plezier gelezen.  
 yes, I have it/that with pleasure read  
 ‘Yes, I’ve enjoyed reading it.’
- b’. Ja, dat heb ik met plezier gelezen.  
 yes that have I with pleasure read  
 ‘Yes, I’ve enjoyed reading it.’

Pronouns in the middle field differ from those in sentence-initial position in that the former can be either referential (*het* ‘it’) or demonstrative (*dat* ‘that’), whereas the latter are normally demonstrative. This is probably related to the fact that topicalized phrases must bear accent, while referential pronouns are normally unstressed. Note that in some cases, referential and demonstrative pronouns are even in complementary distribution as many speakers reject demonstratives in the middle field if their antecedent is [+ANIMATE]. This will become clear by comparing the question-answer pair in (36) to the one in (34).

- (36) a. Weet jij waar Jan is?  
 know you where Jan is  
 ‘Do you know where Jan is?’
- b. Nee, ik heb hem/?die niet gezien.  
 no I have him/that not seen  
 ‘No, I haven’t seen him.’

The examples in (37) show, however, that topic drop is only possible in topicalization constructions: omission of the pronoun in the middle field of the clause, as in (37a), results in an inappropriate response to (35a).

- (37) a. <sup>§</sup>Ja, ik heb met plezier gelezen. [inappropriate response to (35a)]  
 yes, I have with pleasure read  
 ‘Yes, I’ve enjoyed reading.’
- b. Ja, heb ik met plezier gelezen. [appropriate response to (35a)]  
 yes have I with pleasure read  
 ‘Yes, I’ve enjoyed reading it.’

The difference in appropriateness of the two discourse continuations in (37) is due to the fact that the verb *lezen* ‘to read’ receives a pseudo-intransitive interpretation if the omitted pronoun is part of the middle field of the clause but not if it is topicalized. This strongly suggests that the pronoun is still syntactically present in the V1-construction in (37b). Additional support for the hypothesis that the initial position of the V1-constructions of this type is syntactically filled is provided by the fact that topic drop is also allowed with R-pronouns extracted from pronominal PPs like *er/daar ... van* in the (b)-examples in (38). Given that the PP-complement of the verb *horen* obligatorily has a nominal complement, the omitted topic must be syntactically present in (38b’).

- (38) a. Weet jij wat een tapuit is?  
 know you what a wheatear is  
 ‘Do you know what a wheatear is?’  
 b. Nee, ik heb \*(er/daar) nog nooit van gehoord.  
 no I have there/there still never of heard  
 ‘No, I’ve never heard of it before.’  
 b’. Nee, (daar) heb ik nog nooit van gehoord.  
 no there have I still never of heard  
 ‘No, I’ve never heard of it before.’

The discussion above leads to the conclusion that topic drop constructions have a syntactically realized, but phonetically empty constituent in sentence-initial position. This in turn suggests that topic drop constructions involve a (phonetically empty) topic operator, [<sub>CP</sub> OP<sub>Topic</sub> V<sub>finite</sub> [TP .....]], or elision of a topic in sentence-initial position: [<sub>CP</sub> ~~Topic~~ V<sub>finite</sub> [TP .....]]; see Jansen (1981:ch.5), Thrift (2003) and Barbiers (2007) for discussion. Analyses of this sort are supported by the fact that topic drop is excluded in questions; the pronoun *dat* cannot be dropped in the two (b)-examples in (39) because the sentence-initial positions are already occupied by, respectively, the *wh*-phrase *wanneer* and the phonetically empty question operator OP<sub>polar</sub> discussed in Section 11.2.1.

- (39) a. *Het beleg van Laken* is een interessant en onderhoudend boek.  
*Het beleg van Laken* is an interesting and entertaining book  
 b. Zo, wanneer heb je \*(dat) gelezen?  
 so when have you that read  
 ‘Really, when did you read that?’  
 b’. Zo, OP<sub>polar</sub> heb je \*(dat) gelezen?  
 so have you that read  
 ‘Really, have you read that?’

More evidence is provided by the fact that topic drop can be applied to a single constituent only. First consider the examples in (40), which show that topic drop may affect subjects and (in)direct objects alike; cf. Jansen (1981:ch.5).



- (40) a. Waar is Jan? (Die) is al naar huis. [subject]  
 where is Jan that is already to home  
 ‘Where is Jan? He has gone home already.’
- b. Waar is Jan? (Die) heb ik weggestuurd. [direct object]  
 where is Jan that have I away-send  
 ‘Where is Jan? I’ve dismissed him.’
- c. Waar is Jan? (Die) heb ik een boottocht aangeboden. [indirect object]  
 where is Jan that have I a boat.trip prt.-offered  
 ‘Where is Jan? I’ve offered him a boat trip.’

The examples in (41) show that R-parts of pronominal PPs may also be dropped provided that the PP can be split; applying topic drop to the R-part of the pronominal PP in the reaction to the question in (41c') is unacceptable because °R-extraction from temporal adverbial phrases is also excluded—it is instead the adverbial pro-form *dan* ‘then’ in (41c) that is dropped; see Thrift (2003: Section 2.3) and the references cited there for more discussion.

- (41) a. Hoe loopt het project? (Daar) praten we later over. [PP-complement]  
 how walks the project there talk we later about  
 ‘How is the project going? We’ll talk about that later.’
- b. Wat doe je met die kist? (Daar) stop ik boeken in. [complementive]  
 what do you with that box there put I books in  
 ‘What will you do with that box? I will put books in it.’
- c. Wil jij koffie na het eten? Nee, (dan) heb ik liever thee. [adverb]  
 want you coffee after the meal no then have I rather tea  
 ‘Would you like coffee after dinner? No, I prefer tea then.’
- c'. Wil jij koffie na het eten? \*Nee, (daar) heb ik liever thee na.  
 want you coffee after the meal no there have I rather tea after

Despite the fact that topic drop may apply to a large set of clausal constituents, it is impossible to construct cases in which topic drop applies to more than one constituent at the same time; although the subject and the direct object in the two (b)-examples in (42) are both possible targets for topic drop individually, the unacceptability of (42c) shows that they cannot be dropped simultaneously. This follows immediately on the assumption that topic drop requires the topic to be in clause-initial position, and this position can only contain a single constituent.

- (42) a. Wat doet Peter met zijn kapotte printer?  
 what does Peter with his broken printer  
 ‘What will Peter do about his broken printer?’
- b. (Die) gooit hem natuurlijk weg. [subject]  
 that throws him of.course away  
 ‘He’ll throw it away, of course.’
- b'. (Die) gooit hij natuurlijk weg. [direct object]  
 that throws he of.course away  
 ‘He’ll throw it away, of course.’
- c. \*Gooit natuurlijk weg. [subject + direct object]  
 throws of.course away

Topic drop is sensitive to a °recoverability condition: the substantive content of the dropped topic must be reconstructible from the context. This is illustrated by means of the examples in (43), which show that topic drop of a subject does not affect subject-verb agreement. The fact that there is subject-verb agreement in examples such as (43) of course constitutes additional evidence for the hypothesis that the topic is syntactically present.

- (43) a. Waar is Jan? (Die) is<sub>3p.sg</sub> al naar huis.  
 where is Jan that is already to home  
 ‘Where is Jan? He has gone home already.’  
 b. Waar zijn Jan en Marie? (Die) zijn<sub>3p.sg</sub> al naar huis.  
 where is Jan and Marie those are already to home  
 ‘Where is Jan? They have gone home already.’

The same is shown by examples like (44a&b); since reflexive pronouns must have a syntactically present antecedent in their clause, we have to assume that it is present even after topic drop. The examples further show that the form of the reflexive pronoun is determined by the person feature of the omitted topic.

- (44) a. Wat is er met je gebeurd? (Ik<sub>i</sub>) heb mezelf<sub>i</sub> gesneden.  
 what is there with you happened I have myself cut  
 ‘What has happened to you? I’ve cut myself.’  
 b. Wat is er met Peter gebeurd? (Die<sub>i</sub>) heeft zichzelf<sub>i</sub> gesneden.  
 what is there with Peter happened that has himself cut  
 ‘What has happened with Peter? He has cut himself.’

Examples such as (44a) are sometimes considered to be cases of “diary drop” (which can also be found in English); see Haegeman (1990). Diary drop always involves the first person pronoun *ik* ‘I’ and is typically found in ego-documents and letter but it also occurs in speech and folk songs. A typical example of the latter is found in the onset of the following traditional “clapping” song: cf. *handjeklappen* ‘to strike a bargain by clapping hands’. That we are dealing with diary drop is clear from the fact that there are several versions of this song in which the subject pronoun is overtly expressed (which is readily possible without affecting the meter by the use of the proclitic form ‘*k* ‘I’); see [liederenbank.nl](http://liederenbank.nl) for alternative versions.

- (45) Klap, ging naar de markt/Kocht een koe/Stukje lever toe/...  
 clap went to the market/bought a cow/piece [of] liver extra/...  
 ‘I went to the market and bought a cow. I got a piece of liver extra, ...’

Although we do not see any compelling reason for assigning subject drop a special *syntactic* status in Dutch, we added the examples in (46) to show that the number specification of the omitted topic is likewise relevant: reciprocals like *elkaar* ‘each other’ normally have a plural antecedent.

- (46) a. Wat hebben Jan en Els gedaan? (Die<sub>i</sub>) hebben met elkaar<sub>i</sub> gevochten.  
 what have Jan and Els done those have with each.other fought  
 ‘What have Jan and Els done? They’ve fought with each other.’  
 b. \*Wat heeft Jan gedaan? (Die<sub>i</sub>) heeft met elkaar<sub>i</sub> gevochten.  
 what has Jan done that has with each.other fought

A final illustration of the fact that the substantive content of an elided topic must be reconstructible from the context is given in (47). These examples show that supplementives and floating quantifiers can be used despite the fact that they are normally associated with a noun phrase in their own clause.

- (47) a. *Waarom is Jan gearresteerd? Tja, (die) liep naakt op straat.*  
 why is Jan arrested well, that walked nude on street  
 ‘Why has Jan been arrested? Well, he walked in the street nude.’  
 b. *Ken je deze boeken? Ja, (die) heb ik allemaal gelezen.*  
 know you these books yes those have I all read  
 ‘Do you know these books? Yes, I have read them all.’

This section has discussed V1-clauses with topic drop and has shown that there is ample evidence that the initial position of such clauses is syntactically filled by some phonetically empty constituent. Topic-drop constructions thus confirm the claim that the V1 order is merely a superficial *phonetic* phenomenon.

### 11.2.3. *Finite imperatives*

This section discusses finite imperative constructions as illustrated by the examples in (48), which typically have the imperative verb in first position. Subsection I argues that the V1-nature of a finite imperative can be accounted for by assuming that the clause-initial position is filled by a phonetically empty imperative operator expressing imperative mood and/or second person features.

- (48) a. *Kom hier!*  
 come here  
 b. *Ga weg!*  
 go away

Subsection II will discuss a potential problem for the hypothesis that the initial position of finite imperatives is occupied by an empty imperative operator, posed by a special type of finite imperative construction in (49b). The problem here is that the direct object follows the verbal particle and must therefore be in a right-dislocated position. To solve the problem, it has been claimed that the true object is realized as an empty operator (or elided pronoun): we will show that under certain standard assumptions this may be incompatible with the postulation of an empty imperative operator.

- (49) a. *Leg dat boek neer!* [regular placement of object]  
 put that book down  
 ‘Put that book down!’  
 b. *Leg neer, dat boek!* [special placement of object]  
 put down that book

Subsection III will show, however, that it has also been claimed that imperatives like (49b) should not be treated on a par with regular cases like (49a). This would nullify the need of postulating an additional empty operator with the function of direct object for (49b) and thereby solve the potential problem for the postulation of

an empty imperative operator. We will not make a choice between the two proposals but leave this to the reader/future research.

*I. The motivation for a phonetically empty imperative operator*

The verb forms in these examples are called finite because of their placement; while non-finite main verbs always follow verbal particles and °complementives, the unacceptability of the primed examples in (50) shows that the imperative forms under discussion must precede them.

- (50) a. Leg dat boek neer!                      a'. \*Dat boek neer leg!  
           put that book down                      that book down put  
       b. Sla die mug dood!                      b'. \*Die mug dood sla!  
           hit that mosquito dead                      that mosquito dead hit

Verbs in finite imperative clauses typically occur in first position, and in this respect they differ markedly from finite verbs in declarative clauses, which are normally preceded by some constituent; see the contrast between the two examples in (51).

- (51) a. Dat boek geef ik direct terug.                                      [declarative]  
           that book give I immediately back  
           ‘That book I’ll return immediately.’  
       b. \*Dat boek geef direct terug!                                      [imperative]  
           that book give immediately back

One might derive the V1-nature of finite imperatives by hypothesizing that the clause-initial position is filled by a phonetically empty second person subject pronoun. Postulation of such a pronoun would immediately account for the fact that second person reflexive pronouns may occur in imperative constructions; see Section 1.4.2, sub IIA, for discussion and more data. The postulation of a phonetically empty second person subject can also be motivated by the fact that supplementives and floating quantifiers are possible, as these normally must have an associated noun phrase in the clause.

- (52) a. Kijk naar jezelf!  
           look at yourself<sub>sg</sub>  
       b. Kom niet dronken thuis!  
           come not drunk home  
           ‘Don’t come home drunk!’  
       c. Kom allemaal hier!  
           come all here  
           ‘Come here all of you!’

At first sight, the hypothesis concerning a phonetically empty second person pronoun seems to run afoul of the placement of the subject pronouns in the more special imperative construction in (53), which are all more or less equivalent to the more regular form *Ga eens weg!* ‘Get out of the way, please!’; see Section 1.4.2, sub IIC, for a more extensive discussion of this type. These examples show that the subject pronouns must follow the verb in first position.

- |         |                                   |     |                                   |
|---------|-----------------------------------|-----|-----------------------------------|
| (53) a. | Ga jij maar weg!                  | a'. | *Jij ga maar weg!                 |
|         | go you <sub>sg</sub> PRT away     |     | you <sub>sg</sub> go PRT away     |
| b.      | Gaan jullie maar weg!             | b'. | *Jullie gaan maar weg!            |
|         | go you <sub>pl</sub> PRT away     |     | you <sub>pl</sub> go PRT away     |
| c.      | Gaat u maar weg!                  | c'. | #U gaat maar weg!                 |
|         | go you <sub>polite</sub> PRT away |     | you <sub>polite</sub> go PRT away |

Barbiers (2013) noticed, however, that overt expression of subject pronouns requires a particle like *maar* or *eens* to be present: if we replace the particle *maar* in (53) by the locative pro-form *daar* ‘there’, the examples indeed become somewhat marked, while adding the particle *eens* to the resulting structures make them fully acceptable again; this is shown in (54). Barbiers (2013) concludes from this that the overt subject pronouns are in fact licensed by the particles, and not by the verb; he therefore maintains that present-day Dutch imperatives have a phonetically empty subject pronoun licensed by the imperative verb in sentence-initial position.

- |         |   |
|---------|---|
| (54) a. | Ga jij daar <sup>?</sup> (eens) weg!      |
|         | go you <sub>sg</sub> there PRT away       |
| b.      | Gaan jullie daar <sup>?</sup> (eens) weg! |
|         | go you <sub>pl</sub> there PRT away       |
| c.      | Gaat u daar <sup>?</sup> (eens) weg!      |
|         | go you <sub>polite</sub> there PRT away   |

The V1-requirement on finite imperatives does not hold for Middle Dutch and certain varieties of present-day German. Barbiers (2007) suggests that the loss of topicalization and *wh*-movement in Dutch imperatives is related to the decline of specialized imperative forms in the language (the stem *weez-* ‘be’ as in *Wees voorzichtig* ‘Be careful!’ being the only surviving remnant in Standard Dutch). In (55), a Middle Dutch example is given from a 14<sup>th</sup> century manuscript of *De reis van Sente Brandane* (The Voyage of Saint Brandaen); we refer the reader to Van der Horst (2008:543) for more diachronic data and to Barbiers (2007/2013) for similar data from German as well as some Dutch dialects.

- |      |  |   |
|------|--|---|
| (55) | Nu verneemt hoe ouer lanc ...            | [ <i>Sente Brandane</i> ; 14 <sup>th</sup> century] |
|      | now learn <sub>imp.pl</sub> how long ago |   |
|      | ‘Learn now, how long ago ...’            |   |

Barbiers (2013) claims that the overt person marking on the imperative form of the verb makes the covert subject pronoun in clause-initial position superfluous, so that this position remains available for topicalization. For our goal, it suffices to assume that in Standard Dutch the sentence-initial position is filled by some phonetically empty element that expresses imperative mood and/or second person; for convenience we will refer to this element as empty operator (abbreviated as OP in some of the examples below). This empty imperative operator is signaled by the placement of the verb in first position of the clause, which therefore indirectly signals the imperative mood. That the phonetically empty imperative operator blocks topicalization in examples such as (51b) can be supported by the fact that resumptive pronouns in finite imperative left-dislocation constructions cannot be sentence-initially either, but must occupy a position in the middle field of the

clause: the examples in (56) show that while the resumptive pronouns *het/dat* can be clause-initial or clause-external in declarative clauses, finite imperatives allow them only in clause-internal position. We refer the reader to Barbiers (2007/2013) for more discussion.

- (56) a. Dat boek, dat geef ik direct terug. [declarative]  
 that book that give I immediately back  
 ‘That book, I’ll return it immediately.’  
 a’. Dat boek, ik geef het direct terug.  
 that book I give it immediately back  
 ‘That book, I’ll return it immediately.’  
 b. \*Dat boek, dat geef direct terug! [imperative]  
 that book that give immediately back  
 b’. Dat boek, geef het direct terug!  
 that book give it immediately back  
 ‘That book, return it immediately.’

## II. The empty operator analysis of *Leg terug, dat boek!*

The examples in (57) show that finite imperative clauses differ markedly from declarative clauses in that direct objects are often optional and can be placed after verbal particles. The imperative constructions in the primed examples pose a potential problem for the postulation of an empty imperative operator because some analyses proposed for them are not *a priori* compatible with it.

- (57) a. Jan legt \*(dat boek) terug. a’. Leg (dat boek) terug!  
 Jan puts that book back put that book back  
 ‘Jan is putting that book back.’ ‘Put that book back!’  
 b. \*Jan legt terug, dat boek. b’. Leg terug, dat boek!  
 Jan puts back that book put back that book

Den Dikken (1992) argues that constructions such as (57b’) involve a phonetically empty operator with the function of direct object that is moved into first position; this operator licenses the apparent object *dat boek*, which is base-generated to the right of the particle *terug*. This analysis has the advantage that we immediately account for the fact that the noun phrase *dat boek* is optional: the selection restrictions of the verb are satisfied in (58b) because the phonetically empty operator OP functions as the direct object of the sentence: the noun phrase is simply an (optional) °adjunct.

- (58) a. [OP<sub>i</sub> leg *t*<sub>i</sub> terug], dat boek<sub>i</sub>!  
 b. [OP<sub>i</sub> leg *t*<sub>i</sub> terug]

Observe that it is not *a priori* clear that the postulation of the empty operator is crucial: since examples such as (59a) show that topicalized pronouns also license direct objects in the right periphery of the clause, Koopman (2007) claims that imperative clauses such as (57b’) involve an elided object pronoun; we are dealing with a combination of right dislocation and topic drop. That the two operations can

indeed be combined is independently supported by the fact that (in the right context) example (59b) is also fully acceptable.

- (59) a. Dat<sub>i</sub> leg ik zo t<sub>i</sub> terug, dat boek.  
 that put I later back that book  
 ‘I’ll put it back in a moment, that book.’  
 b. ~~Dat~~ leg ik zo terug, dat boek.  
 that put I later back that book

For ease of representation, we will adopt the empty operator movement analysis in what follows without the intention to immediately dismiss the topic drop analysis. Den Dikken motivates the involvement of leftward movement in imperative examples such as (57b’) by pointing out that °parasitic gaps are licensed in such constructions. First, consider the declarative sentences in (60). Example (60a) shows that the adjunct clause introduced by *zonder* ‘without’ must have an overtly realized object pronoun; the indices indicate that this pronoun can be interpreted as coreferential with the object of the main clause. The examples in (60b&c) show that leftward movement of the object of the main clause allows the object pronoun to remain unexpressed; the interpretative gap in the adjunct clause must then be construed as coreferential with the object of the main clause. Since the occurrence of the interpretative gap is “parasitic” on leftward movement of the object of the main clause, such gaps are known as parasitic gaps: see Section 11.3.7 for detailed discussion. Note that acceptability judgments on parasitic gaps differ from speaker to speaker: while some consider the use of a parasitic gap (pg) in (60b&c) fully acceptable, others prefer the use of an overt pronoun.

- (60) a. Hij borg [zonder \*(het)<sub>i</sub> te lezen] het boek<sub>i</sub> op.  
 he put without it to read the book away  
 ‘He put away the book without reading it.’  
 b. Hij borg het boek<sub>i</sub> [zonder pg<sub>i</sub> te lezen] t<sub>i</sub> op.  
 c. Het boek<sub>i</sub> borg hij [zonder pg<sub>i</sub> te lezen] t<sub>i</sub> op.

The crucial observation is that parasitic gaps are also possible in imperative constructions such as (57b’); Den Dikken takes this as evidence for leftward operator movement: example (61a) thus has the representation in (61b). Although Den Dikken’s judgment has been accepted in the literature, example (61a) may be somewhat more marked than the (b)-examples in (60). We will return to this at the end of this section.

- (61) a. Berg [zonder pg te lezen] op, dat boek!  
 put without to read away that book  
 ‘Put away that book without reading it.’  
 b. [OP<sub>i</sub> berg [zonder pg<sub>i</sub> te lezen] t<sub>i</sub> op], dat boek!

Den Dikken’s analysis seems incompatible with Barbiers (2007) hypothesis if we maintain that finite verbs in main clauses can be preceded by at most one constituent, as Barbiers’ imperative operator will block leftward movement of Den Dikken’s empty operator in examples such *Geef terug, dat boek!* ‘Give back, that book!’. Accepting both proposals is only viable if we are willing to stipulate that



Den Dikken's empty operator targets some position in the middle field of the clause, which is in fact what is proposed by Den Dikken (1992) as well as Barbiers (2007). The topic drop analysis proposed by Koopman (2007), on the other hand, is incompatible with Barbiers' hypothesis, as Section 11.2.2 has shown that topic drop is only possible if the pronoun is in sentence-initial position.

As was pointed out by Den Dikken (1992) himself, the empty operator movement analysis of examples such as (57b') meets a number of potential problems. First, examples such as (62) show that while it is possible to place an indirect object in the right-peripheral position of declarative clauses regardless of whether the pronoun *die* 'that' is overtly expressed, this is only possible in the imperative construction if a resumptive pronoun is present.

- (62) a. (Die) moet je dat boek toesturen, die jongen. [declarative]  
 that must you that book prt.-send that boy  
 'You should send him that book, that boy.'
- b. Stuur die/hem dat boek toe, die jongen! [imperative]  
 send that/him that book prt. that boy  
 'Send him that book, that boy!'
- b'. \*Stuur dat boek toe, die jongen!  
 send that book prt. that boy

A second, related problem is that the indirect object is preferably omitted if the direct object is placed in the right periphery of the imperative clauses, while realizing the indirect object is fully acceptable in the case of right dislocation in declarative clauses. This is illustrated by the acceptability contrast between the two primed examples in (63); we use the diacritic % in example (63b') because Den Dikken claims that such examples are marked but grammatical, whereas we found that some speakers find the overt realization of the indirect object quite awkward.

- (63) a. Ik geef Marie/haar dat boek terug. [declarative]  
 I give Marie/her that book back
- a' Dat geef ik Marie/haar terug, dat boek.  
 that give I Marie/her back that book  
 'I'll give it back to Marie/her, that book.'
- b. Geef Marie/haar dat boek terug! [imperative]  
 give Marie/her that book back
- b'. Geef (%Marie/haar) terug, dat boek!  
 give Marie/her back that book

Den Dikken (1992) claims that the contrasts found in (62) and (63) need not surprise us by showing that similar restrictions as in finite imperative constructions are found in other constructions involving empty operator movement. Note that this line of reasoning would again be impossible if we adopt Koopman's (2007) proposal according to which the relevant declarative and imperative constructions both involve a combination of right dislocation and topic drop.

A third problem that needs to be mentioned is that the postulated empty operator movement cannot strand prepositions: while the declarative example in (64a) is acceptable both with and without the R-pronoun *daar*, the R-pronoun must



be overtly realized in the corresponding finite imperative construction, as is clear from the contrast between the two (b)-examples in (64).

- (64) a. (Daar) moet je opnieuw over nadenken, (over) dat probleem.  
 there must you again about prt.-think about that problem  
 ‘You must think about that again, that problem.’  
 b. Denk daar<sub>i</sub> opnieuw [<sub>t<sub>i</sub></sub> over] na, (over) dat probleem!  
 think there again about prt about that problem  
 ‘Think about it again, that problem!’  
 b’. \*OP<sub>i</sub> denk opnieuw [<sub>t<sub>i</sub></sub> over] na, (over) dat probleem!  
 think again about prt about that problem

Den Dikken provides a special account for the unacceptability of (64b’) because preposition stranding is possible in the infinitival imperative in (65), for which he also proposes an empty operator movement analysis; he therefore cannot appeal to special properties of operator movement in this case.

- (65) OP<sub>i</sub> opnieuw [<sub>t<sub>i</sub></sub> over] nadenken, (over) dat probleem!  
 again about prt-think about that problem  
 ‘Think about it again, that problem!’

Various solutions have been proposed for the acceptability contrast between (64b’) and (65), which are all of a highly theory-internal nature: for completeness’ sake, we will briefly summarize them. Den Dikken proposes that R-extraction must be licensed by the main verb and that finite imperatives are special in that they are not able to do this. This somewhat *ad hoc* proposal is not needed according to Barbiers (2007), as he claims that empty operator movement in imperatives is parasitic on case assignment: since the complement of the preposition is not assigned case by the verb, it follows that it cannot undergo empty operator movement either. Of course, this does still not account for the fact that the infinitival imperative in (65) is acceptable. Visser (1996) suggests that this contrast between finite and infinitival imperatives follows from the fact that only the latter allow empty operator movement into sentence-initial position: one way of formally expressing this (not proposed by Visser) is by saying that infinitival imperatives do not have an empty imperative operator. Note in passing, that (64b’) is acceptable without the R-pronoun *daar* if the particle *maar* is added: *Denk maar opnieuw over na, (over) dat probleem*. Barbiers (2007/2013) suggests that this may be due to the fact that such particles create an additional position accessible for an empty operator that functions as the complement of a preposition; see Visser (1996) for a proposal that is similar in spirit.

### III. The analysis of *Leg terug, dat boek!* as forum imperative

An entirely different approach to imperatives of the type *Leg terug, dat boek!* ‘Put back, that book!’ can be found in Postma & Rooryck (2007) and, especially, Postma (2013). They claim that such imperatives are forum imperatives, which are formally characterized by the fact that they are always accompanied by a particle. The examples in (66) show that such particles are not run-of-the-mill verbal particles: while the verb *geven* ‘to give’ cannot normally co-occur with the particle *op*, the

particle is possible in the imperative construction in (66b). Postma (2013) refers to such particles as forum particles.

- (66) a. Marie geeft Peter dat boek (\*op).  
 Marie gives Peter that book prt.  
 ‘Marie gives Peter that book.’  
 b. Geef op (dat boek)!  
 give prt. that book

Forum imperative constructions also have various specific semantic properties. The participants involved in the °eventuality expressed by the verb are always discourse-linked (part of the forum): (i) the implied subject refers to the addressee (as in all imperatives), (ii) an implied indirect object typically refers to the speaker, and (iii) the implied direct object typically refers to some entity in the vicinity of the addressee. Property (i) is clear from the fact that in (67a) the subject pronoun must be second person; any other subject pronoun would lead to an unacceptable result. For completeness’ sake, note that the subject pronoun cannot be realized in the middle field of the clause.

- (67) a. Geef op, jij/jullie!  
 give prt. you<sub>sg</sub>/you<sub>pl</sub>  
 b. \*Geef jij/jullie op!  
 give you<sub>sg</sub>/you<sub>pl</sub> prt.

Property (ii) is illustrated in the (a)-examples in (68): while the regular finite imperative allows a goal to be expressed overtly, this is excluded in the case of the forum imperative. Property (iii) is illustrated in the (b)-examples: the noun phrase *dit boek*, which does not refer to a book in the vicinity of the addressee, can be used in the regular imperative but not in the forum imperative.

- (68) a. Geef Peter dat boek! [regular imperative]  
 give Peter that book  
 a'. \*Geef Peter op, dat boek! [forum imperative]  
 give Peter prt. that book  
 b. Geef (me) dit boek! [regular imperative]  
 give me this book  
 b'. <sup>S</sup>Geef op, dit boek! [forum imperative]  
 give prt. this book

The desired eventuality should furthermore be performed in the speaker’s here-and-now, as is illustrated by the fact that the forum particle cannot be used in examples such as (69b), in which *morgen* ‘tomorrow’ situates the intended eventuality after speech time.

- (69) a. Geef (me) morgen dat boek! [regular imperative]  
 give me tomorrow that book  
 ‘Give me that book tomorrow!’  
 b. \*Geef (me) morgen op, dat boek! [forum imperative]  
 give me tomorrow prt. that book

Crucial for our discussion here is that the implied direct object cannot be overtly expressed in the middle field of the clause, but must appear after the forum particle.

- (70) a. \*Geef dat boek op!  
           give that book prt.  
       b. Geef op, dat boek!  
           give prt. that book

A quick look at the examples in (66) to (70) reveals that the main generalization concerning forum imperatives is that the middle field of the construction is often empty: the arguments of the verb are typically left implicit and spatio-temporal adverbial phrases are impossible due to the fact that the desired eventuality should be located in the here-and-now of the speaker. It is, however, not the case that the middle field must be empty: certain adverbs and particles are possible, for example.

- (71) a. Vertel *snel* op, jij/dat verhaal!  
           tell quickly prt. you/that story  
           ‘Tell me quickly, you/that story!’  
       b. Vertel *eens* op, jij/dat verhaal!  
           tell PRT prt. you/that story  
           ‘Come on, tell me, you/that story!’

Now consider the possibility that particle verbs like *teruggeven* ‘to give back’ may also be used in forum imperatives, but that the verbal particle prevents the realization of an additional forum particle like *op* in *Geef op!* ‘Give it to me’. This would predict that particle verbs can be found in the regular and in the forum imperative construction: in the former case nominal objects must be overtly expressed in the middle field of the clause, whereas in the latter case the nominal objects are omitted or expressed in the right periphery of the clause, that is, after the particle.

- (72) a. Geef dat boek terug! [regular imperative]  
           give that book back  
       b. Geef terug! [forum imperative]  
           give back  
       b'. Geef terug, dat boek! [forum imperative]  
           give back that book

This would also account for the fact that there is no problem in overtly expressing the indirect object in examples such as (72a), but that doing so leads to an infelicitous result in the (b)-examples. This was already illustrated by the (b)-examples in (63), which are repeated in a somewhat different form as (73); example (73b) is marked with a number sign to indicate that it would be fully acceptable as a regular imperative if the noun phrase is interpreted as a theme (direct object).

- (73) a. Geef Marie/haar dat boek terug! [regular imperative]  
           give Marie/her that book back  
       b. #Geef Marie/haar terug! [forum imperative]  
           give Marie/her back  
       b'. %Geef Marie/haar terug, dat boek! [forum imperative]  
           give Marie/her back that book

The fact illustrated earlier in (62) that the indirect object can only be placed after the particle if a resumptive pronoun is present also follows from this proposal: example (74a) can be analyzed as a regular imperative with right dislocation of the indirect object; example (74b) should be analyzed as a forum imperative but is unacceptable because the middle field of the construction is not empty and the indirect object refers to someone other than the speaker.

- (74) a. Stuur die/hem dat boek toe, die jongen! [regular imperative]  
 send that/him that book prt. that boy  
 ‘Send him that book, that boy!’
- b. \*Stuur  $t_i$  dat boek toe, die jongen! [forum imperative]  
 send that book prt. that boy

The contrast with respect to preposition stranding in (75) again follows from the fact that arguments of the verb cannot be expressed in the middle field of a forum imperative. Note in passing that on the assumption that (75b) is a forum imperative, there is reason for assuming that the pronominal part of the preposition *over* is missing, which would of course be another source of the ungrammaticality.

- (75) a. Denk daarover na, (over) dat probleem! [regular imperative]  
 think about.it prt about that problem  
 ‘Think about it, that problem!’
- b. \*Denk over na, (over) dat probleem! [forum imperative]  
 think about prt about that problem

#### IV. Conclusion

This section discussed Barbiers (2007) hypothesis that the V1-order of Dutch imperatives is due to the fact that the sentence-initial position is occupied by an empty imperative operator, which blocks topicalization of other constituents. At first sight, his hypothesis seems incompatible with Den Dikken’s (1992) hypothesis that examples such as *Geef terug, dat boek!* ‘Give back, that book!’ involve empty operator movement into sentence-initial position because the sentence-initial position cannot receive two empty operators at the same time. Den Dikken and Barbiers solved this problem by assuming that the empty operator targets a position other than the specifier of CP. Whether taking this step is really needed is not entirely clear given that *Geef terug, dat boek!* may be an instantiation of the so-called forum imperative, which is characterized by the fact that the participants involved in the eventuality expressed by the verb are discourse-linked (and normally left unexpressed). It should be noted, however, that claiming this would leave us with the problem that parasitic gaps are claimed to be possible in examples such as (61): *Berg [zonder pg te lezen] op, dat boek!* ‘Put away that book without reading it’. In our discussion of this, we already indicated that we are not entirely sure whether parasitic gaps in such examples are as acceptable as parasitic gaps licensed by an overtly realized noun phrase, although they are certainly better than expected if we analyze such cases as forum imperatives. Since we have nothing enlightening to say about the precise status of such examples at the moment, we will not digress on this issue here; future research will have to show which of the two competing analyses of *Geef terug, dat boek!* is the most promising one.

Whatever the outcome of this research, we may conclude for the moment that the V1-nature of finite imperative constructions can be accounted for by adopting Barbiers' (2007) proposal that the clause-initial position of such constructions is filled by an empty imperative operator. This is consistent with the hypothesis that the V1-order is normally a superficial *phonetic* phenomenon.

#### 11.2.4. Narrative inversion

In colloquial speech, there are several narrative inversion constructions in which the clause-initial position remains empty. Two prototypical examples can be found in the following joke, taken from the internet.

- (76) a. Komt een man bij de dokter.  
comes a man at the doctor  
'Man goes to the doctor.'
- b. Zegt de dokter: "Goh tijd niet gezien, ziek geweest?".  
says the doctor gosh! time not seen ill been  
'The doctor says: "Long time no see. Been ill?''

The first sentence of the joke in (76a) is the prototypical onset of a joke, as is clear from the fact that it is used as the title of a television program with ultra-short sketches; cf. Bennis (2007) and [nl.wikipedia.org/wiki/Komt\\_een\\_man\\_bij\\_de\\_dokter](http://nl.wikipedia.org/wiki/Komt_een_man_bij_de_dokter). Examples like these should be seen as expletive constructions, in which the °expletive *er* 'there' has been omitted. This is clear from a Google search (6/4/2014), which reveals that both versions in (77a) frequently occur in a jocular context: the example without the expletive *er* resulted in 60 hits while the one with the expletive resulted in 163 hits (in speech the construction without the expletive may in fact be the more frequent one but we have no data on this). Example (77b) shows that both constructions are similar in that they exhibit the definiteness restriction: the subject cannot be a definite noun phrase. From this we may conclude that we are dealing with a special kind of "topic drop" that affects the expletive *er* 'there'.

- (77) a. (Er) komt een man bij de dokter. [...]  
there comes a man at the doctor  
'Man goes to the doctor. [...]
- b. \*(Er) komt de man bij de dokter. [...]  
there comes the man at the doctor

The continuation of the joke in (76b) provides another case of narrative inversion; cf. Den Besten (1983). Again, it does not seem impossible to consider cases like this as a shorter version of a more elaborate structure: it may involve omission of an adverbial phrase that functions as a connective between the two sentences: *toen* 'then', *meteen* 'immediately', *vervolgens* 'next', *daarna* 'after that'. etc. It often is not quite fitting to replace the inverted V1-structure by a non-inverted V2-structure, as illustrated in the (b)-sentence in (78), taken from Zwart (1997); the primed (b)-example would not be a felicitous continuation of (78a). Note in passing that the pronoun *me* in the (b)-examples is an ethical dative (and not a goal argument).

- (78) a. Afijn, ik naar die vent toe.  
 so I to that guy prt.  
 ‘So, I went over to that guy.’
- b. Begint-ie me toch een verhaal op te hangen.  
 starts-he me PRT a story prt. to hang  
 ‘And he starts to tell me some (crazy) story (you wouldn’t believe it).’
- b’. Hij begint me toch een verhaal op te hangen.  
 he starts me PRT a story prt. to hang

In this case, the V1-structure can again be analyzed as a case in which a sentence-initial element is deleted. Another, quite natural alternative for (78a&b) would be as follows: *Afijn, ik naar die vent toe en daar begint-ie me toch een verhaal op te hangen*. In this example, the sentence-initial position of the second conjunct is filled by the more or less semantically void topic element *daar* ‘there’. For completeness’ sake, we need to point out that Zwart (1997:220) postulates that narrative inversion involves some empty operator, but we are not aware of any independently motivated arguments favoring this assumption over the omission analysis suggested above; we therefore leave this for future research. Regardless of the outcome of such research, it seems that we can already safely conclude that narrative V1-constructions with inversion do not seem to create insurmountable problems for the hypothesis that V1-orders are in fact concealed V2-orders: we are dealing with a superficial *phonetic* phenomenon.

### 11.2.5. Other cases

This section discusses a selection of V1-constructions that have received little attention in the formal, theoretical literature. It is therefore not easy to decide whether constructions like these constitute support or present problems for the hypothesis that V1-orders are more generally a superficial *phonetic* phenomenon.

#### 1. Exhortative constructions

Van der Horst (2008:1977ff) observes that V1-constructions are often used as exhortatives. In such cases, the inverted subject is normally the pronoun *wij* ‘we’; the exhortative reading does not arise in (non-inverted) V2-construction. Two of Van der Horst’s examples are given in (79); the first example is taken from François Haversmidt’s *Winteravondvertellingen* (1894) and the second one from Johan Huizinga’s *Erasmus* (1924).

- (79) a. Verplaatsen wij ons nu naar ...  
 move we REFL now to  
 ‘Let us now move to ...’
- b. Trachten we dien geest van [Erasmus] thans iets dieper te peilen.  
 try we the mind of Erasmus now somewhat deeper to probe  
 ‘Let us try to get a somewhat better understanding of Erasmus’ mind.’

Examples of the type in (79) sound quite outdated and bookish to present-day ears: nowadays we would instead make use of the exhortative *laten*-constructions in (80), which are of course also V1-constructions; again the inverted subject is normally the pronoun *wij* ‘we’.

- (80) a. Laten we ons nu verplaatsen naar ...  
 let us REFL now move to  
 b. Laten we trachten ...  
 let us try

The exhortative *laten*-construction has quite a remarkable history, which can be nicely traced in Van der Horst (2008). The construction originated in the middle ages as a periphrastic conjunctive and could only be used with an object pronoun: *laat ons* ... ‘let us’. The construction with a subject pronoun came into existence in the 14<sup>th</sup> century, while the construction with the object pronoun remained the prominent one until the 16<sup>th</sup> century; cf. Van der Horst (2008:439, 665 & 911). The use of the subject pronoun arose especially in the northern part of the Netherlands (to which it seems to be restricted until this date), possibly in analogy to exhortative constructions of the type in (79); cf. Van der Horst (2008:911). In the 18<sup>th</sup> century, the coexistence of *laten wij* and *laat ons* gave rise to speculations about the meaning difference between the two constructions. Normative grammarians claimed that the former was exhortative and the latter permissive; cf. Van der Horst (2008:1459 & 1787). Given the history of the construction, it seems that we can safely conclude that it does not belong to Dutch °core grammar, and should therefore be put aside in the evaluation of the claim that the V1-order is a superficial *phonetic* phenomenon. For more discussion of V1-structures with *laten*, we refer the reader to Section 5.2.3.4, Sub VI.

## II. Conjunctive

Conjunctives may occasionally surface as V1-structures, but this is not necessary; see Van der Horst (2008:336) for examples from Old Dutch that exhibit the same property.

- (81) a. Leve de koningin!  
 live the Queen  
 b. Lang leve de koningin!  
 long live the Queen

Since examples such as (81) are clearly historical relics and thus part of the periphery of the language, we can put these cases aside as irrelevant for our claim that the V1-order is a superficial *phonetic* phenomenon. It should be noted, however, that we find the same property in the more productive construction in (82) which is formed by means of the “past tense” form of the verb; see, e.g., Paardekooper (1986: 16).

- (82) Was hij maar hier!  
 was he PRT here  
 ‘Wish he was here.’

## III. Fixed constructions

There may be many more or less idiomatized constructions that originated as abbreviations of longer constructions. When someone finally decides to see his GP for a flu jab, he may express his premonition that something will go wrong by



saying something like (83a): constructions of this type may have originated as abbreviated forms of the conditional construction in (83b).

- (83) a. Zal je net zien dat de kliniek gesloten is.  
 will you PRT see that the clinic closed is  
 ‘You’ll see that the clinic is closed.’  
 b. Als ik naar de dokter ga dan zal je net zien dat de kliniek gesloten is.  
 if I to the doctor go then will you PRT see that the clinic closed is  
 ‘When I go to my GP, then you’ll see that the clinic is closed.’

Another case, which is also used in more formal settings or in writing, is given in (84a); cf. Van der Horst & Van der Horst (1999:273). An example such as (84a) typically would be used when the final issue of a (mental) list is addressed. It does not seem too far-fetched that we are dealing with an omitted connective like *dan* in (84b).

- (84) a. Blijft/Rest/Resteert nog het probleem van de koffieautomaat.  
 stays/remains/remains still the problem of the coffee.machine  
 ‘The final issue is the problem of the coffee machine.’  
 b. Dan blijft/rest/resteert nog het probleem van de koffieautomaat.  
 then stays/remains/remains still the problem of the coffee.machine  
 ‘Then we still have the remaining issue concerning the coffee machine.’

The two more or less randomly chosen cases discussed in this subsection show that each individual V1-structure should be investigated in its own right before it is possible to decide whether the structure in question may constitute a problem for the hypothesis that the V1-order is a superficial *phonetic* phenomenon. A full evaluation of this hypothesis will have to wait until we have a more exhaustive inventory of V1-constructions at our disposal.

### 11.3. Clause-initial position is filled

This section discusses clauses in which the clause-initial position in representation (85) is filled by some constituent. This results in V2-clauses (that is, main clauses with the finite verb in second position) or embedded clauses with some constituent preceding the complementizer (which is then normally phonetically empty). We refer the reader to Section 9.1 for a more detailed discussion of representation (85).

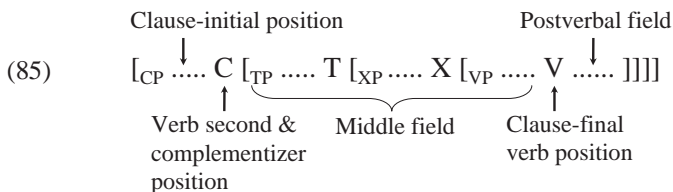

In main clauses, the unmarked filler of the clause-initial position is the subject of the clause, as in (86a), but there are at least four marked constructions in which some other constituent precedes the finite verb: *wh*-questions such as (86b), topicalization constructions such as (86c), and exclamative constructions such as



(86d). The use of °traces in (86b-d) reflects the traditional hypothesis in generative grammar that these examples are derived by movement; traces indicate the base position of the moved phrases (here: the object position in the middle field of the clause). Alternative hypotheses are available, but will not be discussed here.

- (86) a. Jan heeft *Het geuzenboek* van Louis-Paul Boon gelezen. [neutral]  
 Jan has *Het geuzenboek* by Louis-Paul Boon read  
 ‘Jan has read *Het geuzenboek* by Louis-Paul Boon.’
- b. [Welk boek]<sub>i</sub> heeft Jan *t<sub>i</sub>* gelezen? [wh-question]  
 which book has Jan read  
 ‘Which book has Jan read?’
- c. [Dit boek]<sub>i</sub> heeft Jan *t<sub>i</sub>* gelezen. [topicalization]  
 this book has Jan read  
 ‘This book, Jan has read.’
- d. [Wat een boeken]<sub>i</sub> heeft Jan *t<sub>i</sub>* gelezen! [exclamation]  
 what a books has Jan read  
 ‘What a lot of books Jan has read!’

The examples in (87) show that the clause-initial position of declarative embedded clauses normally remains empty; the complementizer precedes the subject and topicalization is excluded. Observe that the complementizer in (87b&c) is in parentheses because this element is normally not phonetically realized in Standard Dutch if the first position is filled by phonetically realized material; if the first position is (phonetically) empty, as in (87a), the phonetic content of the complementizer cannot be omitted.

- (87) a. Marie zegt [<sub>CP</sub> Ø dat [<sub>TP</sub> Jan dit boek niet gelezen heeft]].  
 Marie says that Jan this book not read has  
 ‘Marie says that Jan hasn’t read this book.’
- b. \*Marie zegt [Jan<sub>i</sub> (dat) [<sub>TP</sub> *t<sub>i</sub>* dit boek niet gelezen heeft]].
- c. \*Marie zegt [dit boek<sub>i</sub> (dat) [<sub>TP</sub> Jan *t<sub>i</sub>* niet gelezen heeft]].

The examples in (88) show that the clause-initial position is filled in embedded *wh*-questions, relative clauses and embedded exclamative constructions. It has been noted above that the phonetic content of the complementizer *of/dat* is normally omitted in written and formal Standard Dutch if the clause-initial position is phonetically filled. The complementizers are in parentheses, however, because it is often possible to overtly express the complementizer in such cases in colloquial speech as well as in certain dialects.

- (88) a. Marie vroeg [<sub>CP</sub> wat<sub>i</sub> (of) [<sub>TP</sub> Jan *t<sub>i</sub>* wilde lezen]]. [wh-question]  
 Marie asked what if Jan wanted read  
 ‘Marie asked what Jan wanted to read.’
- b. de boeken [<sub>CP</sub> die<sub>i</sub> (dat) [<sub>TP</sub> hij *t<sub>i</sub>* heeft gelezen]] [relative clause]  
 the books which that he has read  
 ‘the books (that) he has read’
- c. Ik vergat [<sub>CP</sub> [wat een boeken]<sub>i</sub> (dat) [<sub>TP</sub> hij *t<sub>i</sub>* heeft gelezen]]. [exclamative]  
 I forgot what a books COMP he has read  
 ‘I had forgotten that he has read so many books.’

In examples like (86) and (88), the result of movement is immediately visible but there are also constructions for which it has been argued that *wh*-movement affects a phonetically empty element, as a result of which movement can only be detected by the presence of an interpretative gap. An example of such a construction is the so-called comparative deletion construction in (89), in which we indicate the gap by means of *e*. Note in passing that in constructions like these one of the verbs is often omitted under identity; we indicate this here by strikethrough.

- (89)     dat   de tafel [<sub>AP</sub> even lang] ~~is~~ [als   de bank [<sub>AP</sub> e] is]. [comparative deletion]  
           that the table    as long    is as the couch    is  
           ‘that the table is as long as the couch is.’

Note further that certain main clauses with V1-orders have also been analyzed as involving a phonetically element in clause-initial position; we refer the reader to Section 11.2 for a discussion of such cases.

One of the main findings in generative grammar is that the syntactic relation between constituents in clause-initial position and their traces is subject to a set of general conditions; see Ross (1967) and Chomsky (1973/1977), and Cheng & Corver for a very brief historical review (2006). For this reason the movements found in the constructions in (86) and (88) are often referred to by means of a single cover term, *WH*-MOVEMENT; this name is derived from the fact that in English the moved constituents often contains a word starting with *wh*- like the interrogative pronoun *who* in (90a) or the relative pronoun *which* in (90b).

- (90) a. I wonder [*who*<sub>i</sub> you will meet *t*<sub>i</sub> tomorrow].  
       b. the book [*which*<sub>i</sub> you bought *t*<sub>i</sub> yesterday]

The reader should keep in mind, however, that the notion of *wh*-movement covers all movements in (86) and (88), and not only those involving an interrogative or a relative pronoun. The following sections will successively discuss *wh*-movement in *wh*-questions (Section 11.3.1), in relative clauses (Section 11.3.2), in various types of topicalization constructions (Section 11.3.3), in exclamative constructions (Section 11.3.4), and in comparative deletion constructions (Section 11.3.5). Section 11.3.6 addresses the phenomenon of reconstruction, that is, the fact that *wh*-moved phrases behave in certain respects as if they still occupy their base position (the position of their trace); reconstruction is therefore often construed as strong evidence in favor of a movement analysis of *wh*-questions. Section 11.3.7 concludes this section on *wh*-movement with an appendix discussing so-called parasitic gaps, that is, interpretative gaps in the structure that only arise (under certain conditions) if some other gap is present that results from, e.g., *wh*-movement.

### 11.3.1. *Wh*-questions

This section discusses *wh*-movement in so-called *wh*-questions. Section 11.3.1.1 starts with a discussion of *wh*-questions such as given in (91), in which the *wh*-phrase is moved into the initial position of its own clause. We will show that this movement is motivated by the need to form operator-variable chains in the sense of predicate calculus.

- (91) a. Wat<sub>i</sub> leest Peter t<sub>i</sub>?  
 what reads Peter  
 ‘What is Peter reading?’  
 b. Marie vraagt [wat<sub>i</sub> Peter t<sub>i</sub> leest].  
 Marie asks what Peter reads  
 ‘Marie asks what Peter is reading.’

Other issues that will be discussed in Section 11.3.1.1 are the obligatoriness of *wh*-movement in *wh*-questions, pied piping (the fact that *wh*-movement sometimes also affects non-interrogative material that is part of the clausal constituent that includes the *wh*-element), and °stranding (the fact that *wh*-movement sometimes does not affect non-interrogative material that is part of the clausal constituent that includes the *wh*-element).

- (92) a. \*Peter leest wat? [wh-movement is obligatory]  
 Peter reads what  
 b. [Welk boek]<sub>i</sub> leest t<sub>i</sub> Peter? [pied piping of non-interrogative material]  
 which book reads Peter  
 ‘Which book is Peter reading?’  
 c. Wat<sub>i</sub> leest Peter [t<sub>i</sub> voor een boek]? [stranding of non-interrogative material]  
 what reads Peter for a book  
 ‘What kind of book is Peter reading?’

Section 11.3.1.2 continues with a discussion of so-called long *wh*-movement, that is, cases in which a *wh*-phrase is extracted from an embedded clause, as in (93a). There are several restrictions on this type of *wh*-extraction. For example, while long *wh*-movement is fully acceptable from object clauses selected by a verb of saying, it gives rise to a degraded result if the object clause is selected by a factive verb such as *betreuren* ‘to regret’; see the contrast between the examples in (93a&b). Furthermore, long *wh*-movement is completely impossible from adverbial clauses such as (93c). We will discuss a number of factors that may affect the acceptability of this type of long *wh*-movement.

- (93) a. Wat<sub>i</sub> zei Jan [dat Peter t<sub>i</sub> gekocht had]? [non-factive object clause]  
 what said Jan that Peter bought had  
 ‘What did Jan say that Peter had bought?’  
 b. ??Wat<sub>i</sub> betreurde Jan [dat Peter t<sub>i</sub> gekocht had]? [factive object clause]  
 what regretted Jan that Peter bought had  
 Compare: ‘?What did Jan regret that Peter had bought?’  
 c. \*Wat lachte Jan [nadat Peter t<sub>i</sub> gekocht had]? [adverbial clause]  
 what laughed Jan after Peter bought had  
 Compare: ‘\*What did Jan laugh after Peter had bought?’

It should be noted that examples like (93c) cannot be saved by pied piping of the adverbial clause: sentence (94a) is infelicitous as a *wh*-question despite the fact that the same sentence is fully acceptable (with a different intonation contour) if *wat* is interpreted as an existential pronoun, as in (94b).

- (94) a. \*[Nadat Peter wat gekocht had] lachte Jan?  
 after Peter what bought had laughed Jan  
 b. [Nadat Peter wat gekocht had] lachte Jan.  
 after Peter something bought had laughed Jan  
 ‘After Jan had bought something, Jan laughed.’

The unacceptability of both (93c) and (94a) thus shows that in certain syntactic environments a *wh*-element may be inaccessible for *wh*-movement, as a result of which certain questions which can easily be expressed in predicate calculus simply cannot be formulated in natural language by run-of-the-mill *wh*-movement. Section 11.3.1.3 will briefly discuss a set of such syntactic environments in which a *wh*-elements are inaccessible for *wh*-movement, which are often referred to as ISLANDS.

Section 11.3.1.4 concludes with a discussion of so-called multiple *wh*-questions, that is, questions with more than one *wh*-phrase. We will discuss the semantics of such constructions as well as a number of restrictions on their form.

- (95) a. Wie heeft wie geholpen?  
 who has who helped  
 ‘Who has helped who?’  
 b. Wie heeft wat waar verstoppt?  
 who has what where hidden  
 ‘Who has hidden what where?’

#### 11.3.1.1. *Wh*-movement in simplex clauses (short *wh*-movement)

This section discusses *wh*-questions derived by short *wh*-movement, that is, cases in which a *wh*-phrase is moved into the initial position of its own clause; cases of long *wh*-movement, in which a *wh*-phrase is extracted from its own clause and moved into the initial position of some  $\circ$ matrix clause, are postponed until Section 11.3.1.2. The discussion is organized as follows. Subsection I starts by showing that *wh*-movement is near-obligatory in the sense that one *wh*-phrase must be moved into clause-initial position. Subsection II briefly discusses a hypothesis that aims at deriving this obligatoriness of movement from stating that *wh*-movement creates an operator-variable chain in the sense of predicate calculus (although some languages may also use alternative means like scope markers; see, e.g., Cheng (1997), Bayer 2006, and also Section 11.3.1.2, sub V). An example like (96a) can be translated more or less directly into the semantic formula in (96b): if we ignore the feature [-ANIMATE] for the moment, the *wh*-phrase *wat* in clause-initial position corresponds to the question operator  $?x$ , while the  $\circ$ trace of the *wh*-phrase corresponds to the variable *x*. For completeness’ sake, note that in formal semantics the question operator is normally expressed by the lambda operator:  $\lambda x$  READ (Peter, *x*). We will use more informal representations such as (96b).

- (96) a. Wat<sub>i</sub> leest Peter *t*<sub>i</sub>?  
 what reads Peter  
 ‘What is Peter reading?’  
 b.  $?x$  (Peter is reading *x*)

Subsection III restricts the discussion to *wh*-phrases consisting of a single *wh*-word like *wie* ‘who’, *wat* ‘what’ and *hoe* ‘how’; the aim of this subsection is to show that there are no restrictions on *wh*-movement related to the category or the syntactic function of the moved element. Subsection IV briefly shows that the acceptability of embedded *wh*-questions depends on semantic properties of the matrix verb. Subsection V discusses movement of larger *wh*-phrases, that is, phrases containing non-interrogative material besides the *wh*-element such as *wiens boek* ‘whose book’ in (97a). According to the hypothesis to be discussed in Subsection II that *wh*-movement creates an operator-variable chain, it should suffice to simply move the *wh*-element, as the question is only concerned with the identity of the owner/writer of the book, as in the logical formula  $?x$  (Peter is reading  $x$ ’s book); however, example (97b) shows that it is impossible to move the possessive *wh*-pronoun only. The fact that *wh*-movement may (or must) move a larger phrase than is needed for semantic reasons has become known as  $^{\circ}$ pied piping. We will say that in examples such as (97a) the *wh*-element *wiens* obligatorily pied-pipes the non-interrogative part *boek* of the direct object; example (97b) shows that  $^{\circ}$ stranding of this part is excluded.

- (97) a. [Wiens boek]<sub>i</sub> leest  $t_i$  Peter?  
           whose book read Peter  
           ‘Whose book is Peter reading?’  
       b. \*Wiens<sub>i</sub> leest Peter [ $t_i$  boek]?  
           whose reads Peter book

Subsection V will show that pied piping can be forced by the fact that in some cases syntax simply does not allow *wh*-extraction. In other cases, however, stranding is possible or even required. There is, for instance, a contrast between pre- and postpositional phrases: while prepositions are normally pied-piped under *wh*-movement, postpositions are normally stranded. Subsection VI will discuss a number of cases of *wh*-extraction.

- (98) a. Jan is in die boom geklommen? [preposition]  
           Jan is in that tree climbed  
           ‘Jan has climbed into that tree.’  
       a’. In welke boom is Jan geklommen? [pied piping]  
           in which tree is Jan climbed  
           ‘Into which tree has Jan climbed?’  
       b. Jan is die boom in geklommen. [postposition]  
           Jan is that tree into climbed  
           ‘Jan has climbed into that tree.’  
       b’. Welke boom <\*in> is Jan <in> geklommen? [stranding]  
           which tree into is Jan climbed  
           ‘Into which tree has Jan climbed?’

The strongest hypothesis concerning pied piping and stranding would be that the two phenomena are in complementary distribution. We will formalize this by assuming a general constraint “avoid pied piping”, which prohibits pied piping in constructions that allow stranding. Subsection VI will show, however, that there are

a number of potential problems with this constraint: there are cases in which pied piping and stranding are both excluded as well as cases in which they are both possible. For this reason we will briefly discuss the status of the constraint “avoid pied piping” in Subsection VII.

*I. Wh-movement is near-obligatory*

The examples in (99) show that *wh*-movement is sometimes optional in interrogative main clauses; the *wh*-phrase normally occurs in clause-initial position but may also occur in clause-internal position in colloquial speech, provided that it is assigned a high tone, which we indicated by italics; cf. Zwart (2011:22).

- (99) a. Wat ga je doen? [regular form]  
 what go you do  
 ‘What are you going to do?’
- a'. Je gaat *wat* doen? [colloquial speech]  
 you go what do  
 ‘What are you going to do?’
- b. Wanneer ga je naar Utrecht? [regular form]  
 when go you to Utrecht  
 ‘When will you go to Utrecht?’
- b'. Je gaat *wanneer* naar Utrecht? [colloquial speech]  
 you go when to Utrecht  
 ‘When will you go to Utrecht?’

The prosodically marked questions in the primed examples are normally ignored in syntactic descriptions of Standard Dutch, which may be due to the fact that they do not occur in written texts and formal speech. Unfortunately, we will not have much to say about these *wh*-constructions either, for want of sufficient in-depth research, although it is worth mentioning that leaving the *wh*-phrase *in situ* is a typical root phenomenon; Subsection IV will show that it does not occur in embedded *wh*-questions. Note further that the linear strings in the primed examples in (99) are also acceptable if they are construed as °echo-questions: this reading requires the *wh*-element to be assigned emphatic accent. Echo-questions can be used if the hearer has the impression that he did not properly understand the speaker or if he wants to express surprise, disbelief, anger, etc.: echo-question (100a) could be used if B knows that A normally does not bother helping with domestic tasks, and echo-question (100b) could be used to express indignation or anger if A had promised B to spend the day together. We will not discuss echo-questions in what follows here.

- (100) a. A. Ik ga de afwas doen. B. Je gaat *WAT* doen?  
 I go the dishes do you go what do  
 ‘A. I’m going to do the dishes. B. You are going to do WHAT?’
- b. A. Ik ga vandaag naar Utrecht. B: Je gaat *WANNEER* naar Utrecht?  
 I go today to Utrecht you go when to Utrecht  
 ‘A. I’m going to Utrecht today. B. You are going to Utrecht WHEN?’

The discussion of the examples in (99) has shown that *wh*-movement is more or less obligatory: it is the normal means to form a *wh*-question, although occasionally

in colloquial speech it is not found in main clauses with a specific intonation pattern. The proper interpretation of the notion near-obligatoriness of *wh*-movement needs some special attention, though, as it pertains to the interrogative clause as a whole and not to individual *wh*-phrases. That *wh*-questions normally require the clause-initial position to be filled by some *wh*-phrase was already pointed out above. The so-called multiple *wh*-questions in (101) show, however, that it is possible for a *wh*-phrase to stay in its base position, provided the clause-initial position is filled by some other *wh*-phrase; it is in fact impossible to move both *wh*-phrases into clause-initial position, which can be attributed to the restriction that the clause-initial position can be filled by at most one constituent in Dutch; we will return to multiple *wh*-questions in Section 11.3.1.4.

- (101) a. Wie heeft wat gezegd?  
           who has what said  
           ‘Who said what?’  
       a'. \*Wie wat heeft gezegd?  
       b. Wat heeft hij aan wie gegeven?  
           what has he to who given  
           ‘What has he given to whom?’  
       b'. \*Wat aan wie heeft hij gegeven?

This subsection has shown that *wh*-movement is near-obligatory in the sense that the initial position of a *wh*-clauses must be filled by some *wh*-phrase; it is, however, possible for *wh*-phrases to remain in their original position if certain conditions are met, e.g., if the clause-initial position is already filled by some other *wh*-phrase.

## II. A functional motivation for *wh*-movement?

The near-obligatory nature of *wh*-movement in *wh*-questions can be attributed to the fact that this movement is needed to create an operator-variable relation in the sense of predicate calculus; see, e.g., Chomsky (1991) and Dayal (2006: Section 1.1.1). The syntactic representations in the primeless examples in (102), for instance, can be translated more or less directly into the (slightly informal) semantic representations in the primed examples. The preposed *wh*-phrases *wat* ‘what’ and *welk verhaal* ‘which story’ correspond to the question operator  $?x$  plus a restrictor on the variable  $x$  (here: thing/story), while the trace of the *wh*-phrase corresponds to the variable  $x$ .

- (102) a.  $Wat_i$  heeft Peter  $t_i$  gelezen?    b. [ $Welk\ verhaal$ ] $_i$  heeft Peter  $t_i$  gelezen?  
           what has Peter read                    which story has Peter read  
           ‘What has Peter read?’                ‘Which story has Peter read?’  
       a'.  $?x [x: \text{thing}]$  (Peter has read  $x$ )    b'.  $?x [x: \text{story}]$  (Peter has read  $x$ )

Attractive as this may seem, it cannot be the whole story because it is not possible to translate the more complex *wh*-constructions in the primeless examples in (103) directly into the semantic representations given in the primed examples, as only a *subpart* of the *wh*-moved phrase corresponds to the question operator plus restrictor: the possessive pronoun *wiens* ‘whose’ translates into  $?x [x: \text{person}]$ .



- (103) a. [Wiens boek]<sub>i</sub> heeft Peter *t*<sub>i</sub> gelezen?  
 whose book has Peter read  
 ‘Whose book has Peter read?’  
 a’. ?x [x: person] (Peter has read x’s book)  
 b. [Wiens vaders boek]<sub>i</sub> heeft Peter *t*<sub>i</sub> gelezen?  
 whose father’s book has Peter read  
 ‘Whose father’s book has Peter read?’  
 b’. ?x [x: person] (Peter has read x’s father’s book)

The phenomenon of °pied piping thus makes it impossible to propose a one-to-one relationship between syntactic structure and semantic representation: pied piping makes it impossible to state in simple direct terms that *wh*-movement creates an operator-variable chain. This problem is normally solved by assuming some form of °reconstruction of the non-interrogative part of the *wh*-phrase in its original position. That such a mechanism is needed is clear from examples such as (104); since the anaphor *zichzelf* must have a °c-commanding antecedent, the sentence is interpreted as if at least the non-*wh*-part *gerucht over zichzelf* ‘rumor about himself’ still occupies the original position of the *wh*-moved phrase indicated by the trace. We will return to pied piping in Subsection V and to reconstruction in Section 11.3.6.

- (104) [Welk gerucht over zichzelf]<sub>i</sub>] heeft Peter<sub>i</sub> *t*<sub>i</sub> ontkent?  
 which rumor about himself has Peter denied  
 ‘Which rumor about himself has Peter denied?’

Another problem we need to mention here involves multiple *wh*-questions such as (105a). Again, the syntactic structure does not directly correspond with the desirable semantic representation in (105b): because there is only one *wh*-phrase in clause-initial position, we would expect only one operator-variable chain in the corresponding semantic representation, while we seem to need two operator-variable chains to capture the interpretation of (105a). Section 11.3.1.4 will solve this problem by showing that the semantic representation in (105b) is actually not a proper semantic representation of (105a); multiple *wh*-questions do not quantify over entities but over ordered pairs of entities  $\langle x,y \rangle$ , as indicated in the semantic representation in (105b’).

- (105) a. Wie heeft wat gelezen?  
 who has what read  
 ‘Who has read what?’  
 b. ?x ?y (x has read y)  
 b’. ? $\langle x,y \rangle$  (x has read y)

Observe that we omitted the restrictors from our semantic representations in (105). For the sake of simplicity, we will follow this convention from now on whenever the restrictors are not immediately relevant for our discussion.

This subsection discussed the hypothesis that there is a direct link between the obligatory nature of *wh*-movement and the semantic interpretation of *wh*-questions, in the sense that *wh*-movement is instrumental in creating operator-variable chains.



Although we have seen that there are a number of potential problems with this hypothesis, to which we will return in Sections 11.3.1.4 and 11.3.6, we will adopt this hypothesis as a leading idea in the following discussion.

### III. *Categorial status and syntactic function of the wh-phrase*

There seem to be few restrictions on the categorial status of moved *wh*-elements; the only requirement seems to be that an interrogative pro-form be available. We illustrate this here for clausal constituents. The examples in (106) start by showing that all nominal arguments can be questioned.

- (106) • Nominal *wh*-phrases
- a. Jan/Hij heeft Marie/haar die baan aangeboden.  
Jan/he has Marie/her that job prt.-offered  
'Jan/He has offered Marie/her that job.'
  - b. Wie heeft Marie/haar die baan aangeboden? [subject]  
who has Marie/her that job prt.-offered  
'Who has offered Marie/her that job?'
  - c. Wat heeft Jan/hij Marie/haar aangeboden? [direct object]  
what has Jan/he Marie/her prt.-offered  
'What has Jan/he offered [to] Marie/her?'
  - d. Wie heeft ?Jan/hij die baan aangeboden? [indirect object]  
who has Jan/he that job prt.-offered  
'Who has Jan/he offered that job [to]?'

Note that the question mark on *Jan* in (106d) is not intended to suggest that there is a *syntactic* impediment on *wh*-movement of the indirect object if the subject is non-pronominal. The contrast between (106b) and (106d) suggests that there is indeed a tendency to interpret an animate *wh*-phrase in clause-initial position as the subject of the clause, but the fact that the use of a subject pronoun gives rise to a fully felicitous result in both examples shows that this tendency is not syntactic in nature. The examples in (107) show that we find the same tendency in the case of subjects and direct objects. The fact that we do not find a similar tendency in German or English suggests that Dutch clearly has a *computational* disadvantage compared to these languages, in which the intended reading is clear from morphological case marking and word order, respectively.

- (107) a. Wie heeft Jan/hem gezien?  
who has Jan/him seen  
'Who has seen Jan/him?'
- b. Wie heeft ?Jan/hij gezien?  
who has Jan/he seen  
'Who has Jan/he seen?'

PP-arguments like indirect and prepositional objects cannot be replaced by a simple interrogative pro-form. This does not mean that such arguments cannot be *wh*-moved, but that this is only possible if the *wh*-phrase pied-pipes the preposition, as shown in (108). Such examples will be discussed in Subsection V.

- (108) • Prepositional *wh*-phrases
- a. <Aan> wie heeft Jan die baan <\*aan> aangeboden? [indirect object]  
to who has Jan that job prt.-offered  
‘To whom has Jan offered that book?’
- b. <Naar> wie staat Jan <\*naar> te kijken? [prepositional object]  
to who stands Jan to wait  
‘Who is Jan looking at?’

The examples in (109) show that complementives can easily be questioned: we illustrate this by means of three examples of complementives with a different categorial status.

- (109) • Complementive
- a. Wie ben jij eigenlijk? *Een vriend van Jan.* [nominal]  
who are you PRT a friend of Jan  
‘Who are you? I’m a friend of Jan’s.’
- b. Hoe is de nieuwe directeur? *Aardig.* [adjectival]  
how is the new director nice  
‘How is the new director? He’s nice.’
- c. Waar heb je de schaar gelegd? *In de la.* [adpositional]  
where have you the scissors put in the drawer  
‘Where have you put the scissors? In the drawer.’

Example (110) shows that °supplementives can be questioned as well. Note that *hoe* ‘how’ can also be used as a *wh*-adverb so that the interpretation of the question *Hoe vertrok hij?* ‘How has he left’ depends on the context.

- (110) a. Hoe vertrok hij? *Kwaad.* [supplementive]  
how left he angry  
‘How did he leave? He was angry.’
- b. Hoe vertrok hij? *Met de auto.* [adverbial]  
how left he with the car  
‘How did he leave? By car.’

Finally, the examples in (111) show that adverbial phrases with various functions can also be questioned when a *wh*-proform is available. Typical simplex adverbial *wh*-phrases are: *hoe* ‘how’, *hoezo* ‘why/in what way’, *waarom* ‘why’, *wanneer* ‘when’, and *waar* ‘where’.

- (111) • Adverbial *wh*-phrases
- a. Waar slaap ik vanavond? In Peters kamer. [place adverbial]  
where sleep I tonight in Peter’s room  
‘Where will I sleep tonight? In Peter’s room.’
- b. Wanneer vertrekken we? Na de vergadering. [time adverbial]  
when leave we after the meeting  
‘When shall we leave? After the meeting.’
- c. Hoe heb je het gelezen? Oppervlakkig. [manner adverbial]  
how have you it read superficially  
‘How have you read it? Superficially.’

The examples above have amply demonstrated that there are few syntactic restrictions on question formation: clausal constituents with virtually any syntactic function and of any categorial type can be *wh*-questioned. The main restriction is lexical in nature in that there must be a *wh*-word available that can be used to question the intended phrase. This accounts for the fact that non-gradable clausal adverbs such as *misschien* ‘maybe’ cannot be questioned: cf. *\*zeer/hoe misschien* ‘very/how maybe’.

#### IV. *Wh*-movement in embedded clauses

The discussion in the previous subsections was confined to *wh*-movement in main clauses. The primeless examples in (112) show that *wh*-movement is also possible in embedded clauses, and the primed examples show that *wh*-movement is obligatory: the embedded clauses cannot be interpreted as *wh*-questions if the *wh*-phrase stays *in situ*. The number sign in (112a') indicates that the embedded clause is acceptable as a *yes/no*-question if *wat* is interpreted as an existentially quantified personal pronoun (“something”), but this is of course not relevant here.

- (112) a. dat Jan wil weten [*wat* (of) je gaat doen].  
 that Jan wants know what COMP you go do  
 ‘that Jan wants to know what you’re going to do.’  
 a'. #dat Jan wil weten [of je *wat* gaat doen].  
 b. dat Jan wil weten [*wanneer* (of) je naar Utrecht gaat].  
 that Jan wants know when COMP you to Utrecht go  
 ‘that Jan wants to know when you go to Utrecht.’  
 b'. \*dat Jan wil weten [of je *wanneer* naar Utrecht gaat].

The examples in (113) show, however, that embedded *wh*-questions have a limited distribution. The question as to whether they are acceptable depends on the matrix verb; while (112) has shown that *weten* ‘to know’ can license a *wh*-question, the verb *ontkennen* ‘to deny’ cannot.

- (113) a. \*dat Jan ontkent [*wat* (of) je gaat doen].  
 that Jan denies what COMP you go do  
 b. \*dat Jan ontkent [*wanneer* (of) je naar Utrecht gaat].  
 that Jan denies when COMP you to Utrecht go

A warning flag is in order here given that free relatives (relative clauses without a phonetically expressed antecedent) have the appearance of interrogative clauses and can therefore easily be confused with them. They can however be recognized by the fact that they may occur in °argument positions, that is, in the subject/object position preceding the clause-final verbs, as shown in (114a). Caution is only needed when they are extraposed (which is possible with all relative clauses modifying an object) or when there is no verb in clause-final position: cf. *Jan ontkent wat je zegt* ‘Jan denies what you’re saying’.

- (114) a. dat Jan [*wat* je zegt] heeft ontkend.  
 that Jan what you say has denied  
 ‘that Jan has denied what you’re saying.’

- b. dat Jan heeft ontkend [wat je zegt].  
 that Jan has denied what you say  
 'that Jan has denied what you're saying.'

For more discussion of the semantic selection restrictions on embedded clauses, we refer the reader to Section 4.1. The reader is also referred to Section 4.2 for a discussion that embedded infinitival *wh*-questions are mainly found in formal language; in colloquial speech they mainly occur in formulaic expressions such as *Ik weet niet wat te doen/zeggen* 'I don't know what to do/say'. Note in passing that such infinitival clauses are also frequently used as independent expressions (e.g. in instructions or as rhetorical questions): cf. *Wat te doen in het geval van brand* 'What to do in case of fire'. More examples of this type can be found in Vos (1994:148).

### V. Pied piping

Subsection III dealt with *wh*-moved phrases consisting of a single word such as *wie* 'who', *wat* 'what', *hoe* 'how' and *waar* 'where'. This subsection will show that *wh*-movement may also affect larger phrases. This is illustrated in (115b-d) for nominal arguments with an interrogative demonstrative pronoun as determiner.

- (115) a. Jan/Hij heeft Marie/haar die baan aangeboden.  
 Jan/he has Marie/her that job prt.-offered  
 'Jan/He has offered Marie/her that job.'
- b. *Welke functionaris* heeft Marie/haar die baan aangeboden? [subject]  
 which official has Marie/her that job prt.-offered  
 'Which official offered Marie/her that job?'
- c. *Welke baan* heeft Jan/hij Marie/haar aangeboden? [direct object]  
 which job has Jan/he Marie/her prt.-offered  
 'Which job has Jan/he offered [to] Marie/her?'
- d. *Welke sollicitant* heeft <sup>?</sup>Jan/hij die baan aangeboden? [indirect object]  
 which applicant has Jan/he that job prt.-offered  
 'Which applicant has Jan/he offered that book?'

*Wh*-movement of larger phrases has become known as pied piping: the interrogative demonstrative *welke* 'which' is said to pied-pipe the non-interrogative part of the noun phrase into clause-initial position. The reasons for using this notion will be made clear in Subsection A. Subsections B to D continue with a detailed discussion of the restrictions on pied piping of, respectively, NPs, PPs and APs. Subsection E concludes by showing that pied piping of (extended) verbal projections is not possible. We aim at keeping the discussion relatively brief, given that some of the issues are discussed more extensively elsewhere; more detailed discussion on the NP data in Subsection B and the AP data in subsection D can be found in N2.2.1.5 and A3.1.2.4, respectively.

#### A. Pied piping as a repair strategy

The fact that *wh*-moved phrases consisting of a single word such as *wat* 'what' in (116a) move into clause-initial position is expected on the hypothesis discussed in Subsection II that *wh*-movement derives an operator-variable chain in the sense of

predicate calculus. This does not hold, however, for the fact that there are also cases of *wh*-movement in which *wh*-movement applies to phrases including non-interrogative material, like *welke auto* ‘which car’, *wiens auto* ‘whose car’, and *wiens vaders auto* ‘whose father’s car’ in (116b-d); the non-interrogative parts of the *wh*-phrases are in italics.

- (116) a. Wat is de snelste auto?      b. Welke *auto* is de snelste?  
           what is the fastest car      which car is the fastest  
           ‘What is the fastest car?’      ‘Which car is fastest?’  
       c. *Wiens auto* is de snelste?      d. *Wiens vaders auto* is de snelste?  
           whose car is fastest      whose father’s car is the fastest  
           ‘Whose car is fastest?’      ‘Whose father’s car is the fastest?’

The hypothesis that *wh*-movement derives an operator-variable chain requires movement of the interrogative pronouns only; movement of the non-interrogative material in these examples is therefore superfluous from a semantic point of view. Consequently, there must be some other reason for the fact that *wh*-movement of the interrogative demonstrative and possessive pronouns in (116b-d) pied-pipes the non-interrogative parts of these noun phrases. This reason is syntactic in nature: it is simply impossible in Dutch to extract determiners from noun phrases. The examples in (117) show that while it is possible to *wh*-move a full direct object, it is impossible to extract an interrogative demonstrative pronoun from it.

- (117) a. [Welk boek]<sub>i</sub> heeft Marie *t<sub>i</sub>* gelezen?  
           which book has Marie read  
           ‘Which book has Marie read?’  
       b. \*Welk<sub>i</sub> heeft Marie [*t<sub>i</sub>* boek] gelezen?  
           which has Marie book read

The examples in (118) show essentially the same for possessive pronouns: while it is possible to *wh*-move a full direct object, it is impossible to extract (a subpart of) a possessive determiner from it. The (a)-examples provide cases with the formal, genitive form *wiens*, while the (b)-examples provide cases with the more colloquial sequence *wie z’n*; in both cases pied piping is obligatory.

- (118) a. [Wiens boek]<sub>i</sub> heeft Marie *t<sub>i</sub>* gelezen?  
           whose book has Marie read  
           ‘Whose book has Marie read?’  
       a’. \*Wiens<sub>i</sub> heeft Marie [*t<sub>i</sub>* boek] gelezen?  
           whose has Marie book read  
       b. [Wie z’n boek]<sub>i</sub> heeft Marie *t<sub>i</sub>* gelezen?  
           who his book has Marie read  
           ‘Whose book has Marie read?’  
       b’. \*Wie<sub>i</sub> heeft Marie [*t<sub>i</sub>* z’n boek] gelezen?  
           who has Marie his book read

The examples in (119) are added in order to show that the *wh*-element need not be the determiner of the *wh*-moved noun phrase itself but can also be more deeply embedded: the *wh*-element *wiens* is the determiner of the noun phrase *wiens vader*, which in turn is the determiner of the *wh*-moved noun phrase *wiens vaders boek*.

- (119) a. [Wiens vaders boek]<sub>i</sub> heeft Marie *t<sub>i</sub>* gelezen?  
 whose father's book has Marie read  
 'Whose father's book has Marie read?'  
 b. \*[Wiens vaders]<sub>i</sub> heeft Marie [*t<sub>i</sub>* boek] gelezen?  
 whose father's has Marie book read  
 c. \*Wiens<sub>i</sub> heeft Marie [*t<sub>i</sub>* vaders boek] gelezen?  
 whose has Marie father's book read

We conclude from the discussion above that pied piping is a repair strategy that is put to use if *wh*-movement of the *wh*-element itself is blocked for syntactic reasons. Since we will confine ourselves in the next subsections to providing an empirical description of the contexts that disfavor *wh*-extraction and thus favor pied piping, we refer the reader to Corver (1990:ch.7-9) for a more theoretical discussion of the syntactic restrictions on *wh*-extraction (as well as a cross-linguistic examination of the relevant data).

### B. Noun phrases

Example (120a) shows again that pied piping of noun phrases can be triggered by interrogative demonstrative and possessive determiners like *welke* 'which' and *wiens* 'whose'; Subsection A has already shown that this may be related to the fact that it is not possible to extract determiners from noun phrases.

- (120) a. Welk <boek> heeft Marie <\*boek> gelezen? [demonstrative pronoun]  
 which book has Marie read  
 'Which book has Marie read?'  
 b. Wiens <boek> heeft Marie <\*boek> geleend? [possessive pronoun]  
 whose book has Marie borrowed  
 'Whose book has Marie borrowed?'

Interrogative determiners are not only able to pied-pipe head nouns but also various other NP-internal constituents. This is especially conspicuous in the case of postnominal modifiers: while the primeless examples in (121) show that such modifiers can occur in extraposed position, the primed examples show that they must be pied-piped under *wh*-movement; cf. Guéron (1980). Note that the questions in the primed examples are special in that the use of the modifiers presupposes that the speaker has information enabling him to narrow down the set of potential answers: since we may assume that the addressee has greater knowledge of the situation than the speaker and consequently also has this information, explicit mention of the modifier may feel slightly forced. A more extensive discussion of the extraposition and pied-piping behavior of relative clauses can be found in Section N3.3.2.3.

- (121) a. Jan heeft [een boek <met plaatjes>] gekocht <met plaatjes>.  
 Jan has a book with pictures bought  
 'Jan has bought a book with pictures.'  
 a'. [Welk boek <met plaatjes>] heeft Jan gekocht <<sup>\*</sup>met plaatjes>?  
 which book with pictures has Jan bought  
 'Which book with pictures has Jan bought?'

- b. Jan heeft [het boek <dat hij gekocht had>] gelezen <dat hij gekocht had>.  
 Jan has the book that he bought had read  
 ‘Jan has read the book that he had bought.’
- b’. [Welk boek <dat hij gekocht had>] heeft Jan gelezen <\*dat hij gekocht had>?  
 which book that he bought has has Jan read  
 ‘Which book that he has bought has Jan read?’

Subsection A has already shown that the *wh*-element does not have to be an immediate constituent of the pied-piped noun phrase, but can also be more deeply embedded: example (122a) illustrates this again for a possessive pronoun embedded in the determiner of a pied-piped noun phrase. Note in passing that constructions such as (122b) are sometimes judged as less felicitous because the noun phrases tend to become difficult to compute; this also holds for non-interrogative noun phrases like [[*Peters moeders*] *auto*] ‘Peter’s mother’s car’.

- (122) a. We mogen [[haar moeders] *auto*] gebruiken.  
 we are.allowed her mother’s car use  
 ‘We may use her mother’s car.’
- b. [[Wiens moeders] *auto*] mogen we gebruiken?  
 whose mother’s car are.allowed we use  
 ‘Whose mother’s car can we use?’

It also seems possible to embed the *wh*-element *hoe* ‘how’ in a quantifier phrase such as *veel* ‘much/many’, although this fact may be obscured by the orthographic convention to write the formation *hoe* + *veel* as a single word. The fact that *hoeveel* in (123b) corresponds to *heel veel* ‘very many’ in (123a) strongly suggests, however, that we are actually dealing with two separate words.

- (123) a. Marie heeft [[heel veel] boeken] gelezen.  
 Marie has very many books read  
 ‘Marie has read a great many books.’
- b. Hoeveel <boeken> heeft Marie <\*boeken> gelezen? Heel veel!  
 how.many books has Marie read very many  
 ‘How many books has Marie read? Very many!’

Example (123b) also shows that the interrogative quantifier *hoeveel* cannot be extracted from its noun phrase, and thus provides support for the hypothesis put forward in Subsection A that pied piping can be regarded as a repair strategy. Note that extraction of *hoe* is also excluded: \**Hoe<sub>i</sub> heeft Marie [t<sub>i</sub> veel boeken] gelezen?*

Speakers occasionally seem to have varying judgments on pied piping triggered by a more deeply embedded *wh*-element. This can be illustrated quite nicely by examples such as (124b), in which the *wh*-element *hoe* ‘how’ corresponds to the degree adverb *erg* ‘very’ in (124a). In the earlier volume on adjectives (A5.2.1) in this series Broekhuis quoted similar examples as fully acceptable, while Corver (2003:292) has claimed that such examples allow an interpretation as echo-question only. Yet another verdict is levelled by Vos (1994:130), who assigns examples like (124b) a question mark. Clearly, it is difficult to decide whether the markedness of (124b) results from some syntactic constraint or from the computational complexity of the structure, which speakers can easily avoid by using the more or less



synonymous but computationally simpler question *Hoe groot is Els haar auto* 'How big is Els' car?'.  
 (124) a. Els heeft [een [erg grote] auto].  
 Els has a very big car  
 'Els has a very big car.'

- b. % [Een [hoe grote] auto] heeft Els?  
 a how big car has Els  
 'How big a car does Els have?'

For completeness' sake, note that it is also possible to find examples such as (125) on the internet. Although Vos (1994) claims that such examples are acceptable in colloquial speech, we doubt that the construction should be considered as part of standard language as many speakers simply reject it; see Corver (2003) for a more extensive discussion of this construction.

- (125) % [Hoe een grote auto] heeft Els? [cf. *zo'n grote auto* 'such a big car']  
 how a big car has Els  
 'How big a car does Els have?'

The examples discussed so far show that *wh*-elements situated to the *left* of a nominal head may pied-pipe the non-interrogative part of the noun phrase. Pied piping seems to be more difficult, however, if the *wh*-element is situated to the *right* of the nominal head. This contrast becomes immediately clear when we compare the constructions with a prenominal genitive possessor in the (a)-examples of (126) to those with a postnominal *van*-phrase in the (b)-examples; cf. Vos (1994:130).

- (126) a. Marie heeft [Peters<sub>poss</sub> auto] geleend.  
 Marie has Peter's car borrowed  
 'Marie has borrowed Peter's car.'
- a'. [Wiens<sub>poss</sub> auto] heeft Marie geleend?  
 whose car has Marie borrowed  
 'Whose car has Marie borrowed?'
- b. Marie heeft [de auto [van Peter<sub>poss</sub>]] geleend.  
 Marie has the car of Peter borrowed  
 'Marie has borrowed Peter's car.'
- b'. \*[De auto [van wie<sub>poss</sub>]] heeft Marie geleend?  
 the car of who has Marie borrowed

At first sight, example (127a) seems to show that the contrast between the two primed examples in (126) can be derived from the hypothesis that pied piping is a repair strategy: the acceptability of example (127a) suggests that the postnominal *van*-PP can be extracted from the noun phrase. Closer scrutiny reveals, however, that the *van*-PP need not be construed as the possessor of the direct object. First, (127b) shows that the interrogative *van*-PP can also be used if the possessor is expressed by a possessive pronoun, which makes it very unlikely that the *van*-PP also functions as a possessor: cf. \*[*zijn auto van Peter*] 'lit.: his car of Peter'. Second, (127c) shows that the direct object can be pronominalized without affecting the *van*-PP, whereas pronominalization normally affects the full noun phrase. The



examples in (127b&c) therefore show that the *van*-PP must have some other syntactic function; it probably is an indirect object with the thematic role of source (cf. Section 3.3.1.3).

- (127) a. Van wie heeft Marie de auto geleend?  
 of who has Marie the car borrowed  
 b. Van wie heeft Marie zijn<sub>poss</sub> auto geleend?  
 of who has Marie his car borrowed  
 ‘From whom did Marie borrow his car?’  
 c. Van wie heeft Marie hem geleend?  
 of who has Marie him borrowed  
 ‘From who did Marie borrow it?’

The discussion above shows that we should take care not to jump to the conclusion that *wh*-extraction of PPs from noun phrases is possible, but that one should investigate each case in its own right. For example, it is remarkable that most examples that have been analyzed in the literature as cases of *wh*-extraction of PPs from noun phrases involve PPs headed by *van* or *voor*. However, Section N2.2.1.5, sub III, has shown that *van*- and *voor*-PPs can also be used as restrictive adverbial phrases. It is therefore imperative to investigate cases with other prepositions in order to establish conclusively that *wh*-extraction of postnominal PPs is possible, but the primed examples in (128) show that such cases normally do not allow *wh*-extraction; cf. Vos (1994:139-40) and Broekhuis (2014).

- (128) a. Els zal morgen [haar klacht [tegen Peter]] intrekken.  
 Els will tomorrow her complaint against Peter withdraw  
 ‘Els will withdraw her complaint against Peter tomorrow.’  
 a’. \*[Tegen wie]<sub>i</sub> zal Els morgen [haar klacht  $t_i$ ] intrekken?  
 against who will Els tomorrow her complaint withdraw  
 b. Het leger heeft [een aanval [op de president]] verijdeld.  
 the army has an attack on the president prevented  
 ‘The army has prevented an attack on the president.’  
 b’. ??[Op wie] heeft het leger [een aanval  $t_i$ ] verijdeld?  
 on who has the army an attack prevented

Let us now return to the hypothesis that pied piping is a repair strategy. Given that stranding is excluded or at least quite marginal in the primed examples in (128), this hypothesis predicts that the pied piping examples in (129) are acceptable, but this is not borne out: these examples are impossible as *wh*-questions.

- (129) a. \*[Haar klacht [tegen wie]]<sub>i</sub> zal Els morgen  $t_i$  intrekken?  
 her complaint against who will Els tomorrow withdraw  
 b. \*[Een aanval [op wie]]<sub>i</sub> heeft het leger  $t_i$  verijdeld?  
 an attack on who has the army prevented

From this, it follows that the hypothesis that pied piping is a repair strategy should not be interpreted in such a way that pied piping of the remainder of the noun phrase can be used to form the desired question whenever *wh*-extraction is excluded, that is, it may be the case that certain semantically plausible questions

simply cannot be formulated for reasons yet to be determined; see De Vries (2002:section 8.5) for a specific proposal.

C. PPs

The examples in (130) show that *prepositional* phrases with an interrogative pronominal complement require pied piping; this is illustrated for such PPs in various syntactic functions. Since stranding of the preposition would invariably lead to unacceptability, these examples are in full accordance with the hypothesis put forth in Subsection A that pied piping can be regarded as a repair strategy. We will ignore the stranding data in this subsection, but return to them in Subsection VI, where the stranding behavior of *post* and *circumpositional* phrase will be discussed. Note in passing that all examples in (130) involve the [+ANIMATE] pronoun *wie* ‘who’; we will see in Subsection VI that the [-ANIMATE] pronoun *wat* ‘what’ is not possible in this context, but we will also ignore this for the moment.

- (130) a. Op *wie* wacht je? [prepositional object]  
 for whom wait you  
 ‘Who are you waiting for?’
- b. Aan *wie* heb je dat boek gegeven? [indirect object]  
 to whom have you that book given  
 ‘To whom have you given that book?’
- c. Naast *wie* zullen we Peter zetten? [complementive]  
 next.to whom will we Peter put  
 ‘Next to whom shall we place Peter?’
- d. Na *wie* word jij geholpen? [adverbial]  
 after who are you helped  
 ‘After who will you be served?’

The *wh*-element triggering pied piping need not be the complement of the pied-piped PP but can also be more deeply embedded. The examples in (131) illustrate this for a prepositional object, a complementive and an adverbial phrase, in which the *wh*-element functions as the determiner of a nominal complement of the pied-piped PP.

- (131) a. [Op [welk/wiens boek]] zitten we nog te wachten? [prepositional object]  
 for which/whose book sit we still to wait  
 ‘Which/Whose book are we still waiting for?’
- b. [Op [welk/wiens bureau]] heeft Marie het dossier gelegd? [complementive]  
 on which/whose desk has Marie the file put  
 ‘On which/whose desk has Marie put the file?’
- c. [In [welke/wiens kamer]] zullen we vergaderen? [adverbial]  
 in which/whose room will we meet  
 ‘In which/whose room shall we have our meeting?’

The examples in (132) show that the degree of embedding can be even greater. Example (132a) shows that the degree modifier *hoe* ‘how’ of a quantifier of a nominal complement of a PP will ultimately pied-pipe the complete PP. And (132b) shows that the degree modifier *hoe* ‘how’ of an attributive modifier of a nominal

complement of a PP will ultimately pied-pipe the complete PP; a Google search (5/14/14) on the string [*met een hoe grote*] has shown that such examples can easily be found on the internet both in main and in embedded clauses, despite the fact that they are more complex than the disputed example <sup>%</sup>[*Een [hoe grote] auto*] *heeft Els?* ‘How big a car does Els have’ in example (124b) from Subsection B.

- (132) a. [Met [[hoeveel] mensen]] gaan jullie naar Japan?  
 with how.many people go you to Japan  
 ‘With how many people are you going to Japan?’  
 b. [Met [een [hoe grote] groep]] zijn jullie in Japan?  
 wit a how big group are you in Japan  
 ‘With how big a group are you in Japan.’

In the examples discussed so far the *wh*-element is located in prenominal position of the nominal complement of the PP. At first sight, it seems that the result is infelicitous if the *wh*-element is situated in postnominal position, as shown by the primed examples in (133). The percentage signs indicate that examples like these are often claimed to allow an echo-interpretation only (cf. Vos 1994:127), but that there are also speakers who allow them as regular *wh*-questions and attribute their markedness to computational complexity (cf. De Vries 2002:section 8.5).

- (133) a. Marie wacht [op [de broer [van Els]]]  
 Marie wait for the brother of Els  
 ‘Marie is waiting for Els’ brother.’  
 a'. <sup>%</sup>[Op [de broer [van wie]]] wacht Marie?  
 for the brother of who waits Marie  
 b. Marie loopt [achter [de broer [van Els]]].  
 Marie walks behind the brother of Els  
 ‘Marie is walking behind Els’ brother.’  
 b'. <sup>%</sup>[Achter [de broer [van wie]]] loopt Marie?  
 behind the brother of who walks Marie

Vos (1994) has also shown that pied piping is fully acceptable in *wh*-questions like (134a). She suggests that this is only possible if the postnominal PP functions as a modifier, but this would wrongly predict that examples such as (134b) would be unacceptable, given that the relational noun *centrum* clearly selects the PP *van welke stad* (see N1.2.3); to our ears this example has more or less the same status as (134a).

- (134) a. [Op [een taxi [van welk bedrijf]]] wacht u?  
 for a cab of which company wait you  
 ‘For a cab of which company are you waiting?’  
 b. [In [het centrum [van welke stad]]] zou je wel willen wonen?  
 in the center of which city would you PRT want live  
 ‘In the center of which city would you like to live?’

An alternative explanation for the acceptability contrast between the *wh*-examples in (133) and (134) might be that the complex noun phrases in the primed examples in (133) alternate with the structures with a possessive pronoun (*[op/achter [wiens*

*broer*]), while such alternants are not available for the noun phrases in (134). The markedness of the primed examples in (133) can then be attributed to syntactic °blocking, in the sense that the structures with a possessive pronoun are simply favored; this would be in line with De Vries' suggestion that the markedness of the primed examples in (133) is due to their computational complexity.

There may be other factors affecting the acceptability judgments. Vos (1994) claims that an example such as (135a) is unacceptable despite the fact that it seems to involve the same degree of syntactic complexity as the examples in (134). De Vries (2002) considers similar cases acceptable, but difficult to comprehend, which suggests that the infelicitousness of this example may again be non-syntactic in nature. What we would like to suggest here is that the cause of the awkwardness is located in the nature of the nouns involved: the nouns *broer* 'brother' and *vriend* 'friend' in (135) are both relational nouns and can therefore only receive a proper interpretation if the relational argument is known to the addressee. Out-of-context this condition is not fulfilled in (135a) for the noun *vriend* and it may be that this causes the degraded status of this example. That this line of thinking may be on the right track is supported by the fact that example (135a) does improve if we replace the relational noun *vriend* by a non-relational noun such as *meisje* 'girl', as in (135b), which is as acceptable as example (134b).

- (135) a. \*?<sup>?</sup>[Met [de broer [van welke vriend]]] heb je gedanst?  
with the brother of which friend have you danced  
'With the brother of which friend have you danced?'  
b. [Met [de broer [van welk meisje]]] heb je gedanst?  
with the brother of which girl have you danced  
'With the brother of which girl have you danced?'

The discussion above suggests that *wh*-elements in postnominal position are able to trigger pied piping of PPs, unless they are part of a postnominal *van*-PP that has an alternative expression as a prenominal possessive pronoun. The discussion of the examples in (135) has further shown that in some cases there may be non-syntactic factors at play that obscure the proper syntactic generalization; since these factors have not been investigated in full yet, we have to leave them to future research.

#### D. APs

Pied piping of APs is quite restricted and normally involves the interrogative degree adverb *hoe* 'how'. This is illustrated in (136) for a complementive and an adverbially used AP. The fact that the adjectives cannot be stranded shows that cases like these are in accordance with the hypothesis put forward in Subsection A that pied piping is a repair strategy.

- (136) a. Hoe <oud> ben jij <\*oud>? [complementive]  
how old are you  
'How old are you?'  
b. Hoe <zorgvuldig> heb je dat <\*zorgvuldig> gelezen? [adjunct]  
how carefully have you that read  
'How carefully have you read that?'

The degree adverb *hoe* can also be more deeply embedded as part of a gradable degree modifier such as *druk* 'busy' in (137). The (b)-examples show that in such cases pied piping sometimes gives rise to a marked result; the preferred option seems to be *wh*-extraction of the complete adverbial modifier although preferences seem to differ from case to case and speaker to speaker, for which reason Corver (1990:ch.8) marked both (b)-examples as grammatical.

- (137) a. Jan is [[erg druk] bezig].  
 Jan is very lively busy  
 'Jan is very busy.'
- b. [Hoe druk]<sub>i</sub> is Jan [<sub>t<sub>i</sub></sub> bezig]? [stranding]  
 how lively is Jan busy
- b'. <sup>?</sup>[[Hoe druk] bezig]<sub>i</sub> is Jan <sub>t<sub>i</sub></sub>? [pied piping]  
 how lively busy is Jan

The contrast with respect to the stranding behavior of the simple degree modifier *hoe* and the complex modifier *hoe A* is illustrated again in the examples in (138): while the complex *wh*-phrase *hoe goed* in (138a) must be construed as a degree modifier of *bereikbaar*, the simplex *wh*-phrase *hoe* in (138b) cannot; it can only be construed as a manner adverbial.

- (138) a. Hoe goed is dat dorp bereikbaar?  
 how well is that village accessible  
 'How (easily) accessible is that village?'
- b. Hoe is dat dorp bereikbaar?  
 how is that dorp approachable  
 'How can that village be reached?'

The preference for stranding (if real) only holds for cases such as (137), in which the AP is a complementive. In other functions such as supplementive, pied piping is the only option. This contrast is illustrated in (139).

- (139) a. Hoe goed <<sup>?</sup>verzekerd> is uw huis <verzekerd>? [complementive]  
 how well insured is your house  
 'How well is your home insured?'
- b. Hoe goed <verzekerd> ging Jan <\*verzekerd> op vakantie? [supplementive]  
 how well insured went Jan on vacation  
 'How well insured did Jan go on vacation?'

For completeness' sake, the examples in (140) show that adjectives cannot be pied piped by their complement: (140a) shows that *wh*-movement of the PP *op wie* must strand the adjective *boos* and (140b) shows that *wh*-movement of the noun phrase *welke opera* must strand the adjective *zat*.

- (140) a. <Boos> op wie is Peter <boos>?  
 angry at who is Peter  
 'Who is Peter angry with?'
- b. Welke opera <<sup>\*?</sup>zat> is Jan <zat>?  
 which opera fed.up is Jan  
 'Which opera is Jan fed up with?'

We refer the reader to Section A3.1.2.4 for more data and a more extensive discussion. Pied piping of APs by a *wh*-element to the right of the adjectival head does not seem to occur; Subsection VI will show that such *wh*-elements normally strand (part of) the AP.

*E. Verbal (extended) projections*

*Wh*-movement does not pied-pipe verbal projections. Example (141), for instance, shows that *wh*-movement of a direct object cannot pied-pipe the VP it is part of, but must be extracted from it. Note in this connection that Section 11.3.3, sub VIC, will show that °VP-topicalization is possible: [*Een boek gelezen*]<sub>i</sub> heeft Jan *t<sub>i</sub>*.

- (141) a. Wat<sub>i</sub> heeft Jan [<sub>VP</sub> *t<sub>i</sub>* gelezen]?  
 what has Jan read  
 ‘What has Jan read?’  
 b. \*[<sub>VP</sub> Wat gelezen]<sub>i</sub> heeft Jan *t<sub>i</sub>*?  
 what read has Jan

Similarly, a *wh*-phrase that is part of an embedded object clause cannot pied-pipe the clause (despite the fact that topicalization of clauses is possible), but must be extracted from it.

- (142) a. Wat<sub>i</sub> zegt Jan [dat hij *t<sub>i</sub>* gelezen heeft]? [wh-extraction]  
 what says Jan that he read has  
 ‘What does Jan say that he has read?’  
 b. \*[dat hij wat gelezen heeft]<sub>i</sub> zegt Jan *t<sub>i</sub>*? [pied piping]  
 that he what read has says Jan

The patterns in (141) and (142) are of course expected on the basis of the hypothesis put forward in Subsection A that pied piping is a repair strategy. It should be noted, however, that pied piping of an embedded clause is also impossible if *wh*-extraction is blocked, for example, if the *wh*-element is part of an adverbial clause. The examples in (143b-c) show that pied piping and stranding both lead to an unacceptable result and example (143d) shows that refraining from *wh*-movement is not an option either. As a consequence, it is simply impossible to phrase the desired question. Note that the linear strings in (143c&d) are acceptable as declaratives if *wat* is interpreted as the existential quantifier “something”, but this is of course not relevant to our present discussion.

- (143) a. Jan vertrok [nadat hij het boek gekocht had].  
 Jan left after he the book bought had  
 ‘Jan left after he had bought the book.’  
 b. \*Wat<sub>i</sub> vertrok Jan [nadat hij *t<sub>i</sub>* gekocht had]? [wh-extraction]  
 c. \*[Nadat hij wat gekocht had] vertrok Jan? [pied piping]  
 d. \*Jan vertrok [nadat hij wat gekocht had]? [no wh-movement]

The impossibility of formulating certain questions is not as exceptional as it may seem at first sight, as this is generally the case if a *wh*-element occurs in a so-called syntactic island; we will return to this issue in Section 11.3.1.3.

*F. Conclusion*

This subsection has shown that pied piping is possible if the *wh*-element is embedded in a noun phrase, an AP or a PP, but impossible if it is embedded in an (extended) verbal projection. For the cases discussed here it seems observationally adequate to say that pied piping is possible whenever stranding (*wh*-extraction) is excluded. Subsection VI on stranding will discuss more cases that are also covered by this generalization, while Subsection VII will show that there are also cases that run afoul of it. The discussion in this subsection was somewhat complicated by the fact that the judgments in the literature are sometimes contradictory; we argued that this may be due to the interference of a number of non-syntactic factors, which should be further investigated in the future. More extensive data sets on pied piping are given in Corver (1990:ch.7-10), Vos (1994), and De Vries (2002:section 8.5).

*VI. Stranding*

Subsection V discussed cases in which *wh*-movement pied-pipes a clausal constituent. There are, however, also cases of *wh*-movement that partially strand clausal constituents: these will be discussed in this subsection. For reasons of presentation we start with *wh*-extraction from PPs, after which we will discuss cases involving noun phrases and APs. *Wh*-extraction from clauses is not discussed here; some core data were already presented in subsection V and a more detailed treatment will be given in Section 11.3.1.2.

*A. Wh-extraction from PP*

Subsection VC has shown that *wh*-movement of the nominal complement of a prepositional phrase normally pied-pipes the full PP. This subsection will show, however, that there are also cases in which *wh*-movement of the nominal complement strands the adposition; this holds for pronominal, postpositional and circumpositional PPs. Our discussion of these cases is followed by an attempt at an analysis. We conclude with a discussion of stranding by *wh*-movement of the modifier of a PP.

*1. Complements of pronominal PPs (R-extraction)*

The primeless examples in (144) show again that pied piping of prepositional phrases gives rise to an acceptable result regardless of the syntactic function of the PP, while the primed examples show that stranding of the preposition is impossible. In (144) we are dealing with a pronominal complement, *wie* ‘who’; we refer the reader to Subsection VC for examples that show that judgments do not change if the *wh*-element is embedded in the complement of the preposition, such as the demonstrative pronoun *welke* ‘which’ or the possessive pronoun *wiens* ‘whose’.

- (144) • Prepositional phrase with a pronominal *wh*-complement
- a. Naar wie kijk je? [prepositional object]  
 at who look you  
 ‘Who are you looking at?’
- a'. \*Wie<sub>i</sub> kijk je [naar t<sub>i</sub>]?  
 who look you at



- b. Naast wie zullen we Peter zetten? [complementive]  
 next.to whom will we Peter put  
 'Next to whom shall we put Peter?'
- b'. \*Wie zullen we Peter [naast  $t_i$ ] zetten?  
 who will we Peter next.to put
- c. Na wie word jij geholpen? [adverbial]  
 after who are you helped  
 'After who will you be helped?'
- c'. \*Wie word jij [na  $t_i$ ] geholpen?  
 who are you after helped

The results change drastically if the interrogative complement is inanimate. The inanimate pronoun *wat* 'what' normally cannot occur as the complement of a preposition but triggers °R-pronominalization; it surfaces as the °R-word *waar*, which precedes the preposition. The examples in (145) show that *wh*-movement of *waar* may strand the preposition (which we refer to as °R-extraction) if the PP is a complement of the verb or a complementive, but not if it is an adverbial phrase of time or place.

- (145) • Pronominal PPs: *waar* + P
- a. Waar <°naar> kijk je <naar>? [prepositional object]  
 where to look you  
 'What are you looking at?'
- b. Waar <°in> zullen we deze ring <in> stoppen? [complementive]  
 where into will we this ring put  
 'What will we put this ring into?'
- c. Waar <°na> moest hij nu <\*na> weg: het 1<sup>e</sup> of het 2<sup>e</sup> bedrijf? [adverbial]  
 where after must he PRT away the 1<sup>st</sup> or the 2<sup>nd</sup> act  
 'After what did he have to leave: the first or the second act?'

The question marks in (145a&b) are used to express that for many speakers R-extraction is the preferred option in colloquial speech; pied piping is, however, fully acceptable in formal speech and written language. The question mark in example (145c) is used to indicate that the use of the pronominal PP *waarna* 'after what' is slightly clumsy and that speakers would normally use the simplex adverb *wanneer* 'when'; nevertheless, the acceptability contrast between pied piping and stranding is clear. The main conclusion that we can draw from the examples in (145) is that stranding is readily possible in at least certain syntactic configurations. Note that the syntactic restriction is not simply that the PP cannot be an adjunct: some adverbial phrases such as the instrumental PP in (146) do allow *wh*-extraction. We will not discuss the syntactic restrictions on R-extraction here, but refer the reader to the extensive discussion of this in Section P5.3.

- (146) a. Jan heeft de wijnfles met een schroevendraaier geopend.  
 Jan has the wine.bottle with a screw.driver opened  
 'Jan has opened the wine bottle with a screw driver.'
- b. Waar heeft Jan de wijnfles mee geopend?  
 where has Jan the wine.bottle with opened  
 'What has Jan opened the wine bottle with?'



2. *Complements of postpositional phrases*

*Wh*-extraction is also possible with complements of *postpositional* phrases, which have a restricted syntactic use as clausal constituent: they occur as complementives only. The examples in (147b&c) show that the *wh*-element can be the complement of the PP itself or be embedded in the complement of the PP. The use of the dollar sign indicates that example (147b) does not feel fully natural as a *wh*-question, but that the markedness is not syntactic in nature; the reason for assuming the latter is that stranding of the postposition is fully acceptable in (147c).

- (147) • Postpositional phrase with a *wh*-complement
- a. De angstige kat is [die boom in] gevluht.  
the frightened cat is that tree into fled  
'The frightened cat has fled into that tree.'
  - b. Wat <\*>in is de kat <<sup>\$</sup>in> gevluht?  
what in is the cat into fled  
'What has the cat fled into?'
  - c. Welke boom <in> is de kat <in> gevluht?  
which tree into is the cat fled  
'Which tree did the cat flee into?'

It is not immediately clear why stranding the postposition in (147b) gives rise to a marked result. It may be due to the fact that the postposition *in* a priori restricts the set of possible answers to entities with an interior, which suggests that the speaker has specific prior knowledge, which may favor an echo-reading of this example. The echo-reading does not arise in (147c) because the speaker's prior knowledge has been made explicit in the non-interrogative part of the noun phrase; the cat has fled into some tree and the speaker simply wants to know which one.

3. *Complements of circumpositional phrases*

Circumpositional phrases are like postpositional phrases in that they are not used as prepositional objects or adverbial phrases, but occur as complementives only. The examples in (148b&c) show, however, that they also behave like prepositional phrases in that the interrogative pronoun *wie* cannot be extracted by *wh*-movement and that *wh*-movement of the interrogative R-word *waar* strands the remainder of the circumpositional phrase. This is illustrated in (148b&c).

- (148) a. Jan sprong [over Peter/het paaltje heen]?  
Jan jumped over Peter/the pole HEEN  
'Jan jumped over Peter/the pole.'
- b. \*Wie<sub>i</sub> sprong Jan [over t<sub>i</sub> heen]?  
who jumped Jan over HEEN  
'Who did Jan jump over?'
  - c. Waar<sub>i</sub> sprong Jan [over t<sub>i</sub> heen]?  
where jumped Jan over HEEN  
'What did Jan jump over?'

Circumpositional phrases cannot readily be pied-piped as a whole in colloquial speech: the next subsection will show that the unacceptability of (149a) may be

related to the fact that circumpositional phrases allow *wh*-movement to pied-pipe the first member of the circumposition, as shown in (149b); cf. P1.2.5.3 for detailed discussion.

- (149) a. \*?<sub>i</sub>[Over wie heen]<sub>i</sub> sprong Jan t<sub>i</sub>?  
           over who HEEN jumped Jan  
       b. [Over wie]<sub>i</sub> sprong Jan [t<sub>i</sub> heen]?  
           over who jumped Jan HEEN  
           ‘Who did Jan jump over?’

It should be noted that the same reasoning cannot be extended to account for the markedness of (150a), as (150b) is also degraded. The contrast between (149b) and (150b) may however be related to the contrast between the two examples in (148b&c): example (150b) may be syntactically blocked by example (148c), in which even less material has been *wh*-moved; example (149b) is not syntactically blocked because example (148b) is not acceptable.

- (150) a. \*?<sub>i</sub>[Waar over heen] sprong Jan t<sub>i</sub>?  
           where over HEEN jumped Jan  
       b. ??<sub>i</sub>[Waar over]<sub>i</sub> sprong Jan [t<sub>i</sub> heen]?  
           where over jumped Jan HEEN

#### 4. An attempt at analysis

It looks as if a relatively simple explanation can be formulated for the data found in (144)-(150), but it will require a number of brief digressions. First, the fact illustrated in (149b) that circumpositional phrases can be split suggests that the first and second member of the circumposition do not constitute a single lexical unit; Section P1.2.6 concluded from this that circumpositional phrases should actually be analyzed as complex structures in which the second member (here: *heen*) is a postpositional-like element selecting a PP-complement. For our limited descriptive purpose here we will assume the structures in (151), but we refer the reader to Section P1.2.6 for arguments showing that these structures may actually be more complex in the sense that post and circumpositional phrases involve PP-internal movement.

- (151) a. Prepositional phrase: [<sub>PP</sub> P NP]  
       b. Postpositional phrase: [<sub>PP</sub> NP P]  
       c. Circumposition phrase: [<sub>PP</sub> [<sub>PP</sub> P NP] P]

Second, Koster (1987: Section 4.5) argued on the basis of examples like (144), (145) and (147) that the choice between pied piping and stranding depends on two syntactic factors, which we give here in an informal form as the descriptive generalizations in (152); see also Van Riemsdijk (1978). Since prepositions precede their complement, clause (152a) accounts for the unacceptability of stranding in (144). The two clauses in (152) are both satisfied in the case of the pronominal PPs in (145a&b) and the postnominal PPs in (147b&c), which are therefore correctly predicted to allow stranding. Since adverbial clauses are not selected by the verb,

clause (152b) is not satisfied in (145c), which is therefore correctly predicted to be unacceptable.

- (152) *Wh*-movement of a complement may strand the head of a PP if and only if:
- the adpositional head follows its complement; this holds for postpositions and prepositions that head a pronominal PP;
  - the adpositional phrase is selected by the main verb, the head of a dependent of the main verb, the head of a dependent of a dependent of the main verb, etc.

It should be noted, however, that there is a problem with instrumental PPs in examples such as (146) because clause (152b) wrongly predicts *wh*-extraction to be unacceptable in these examples (unless we assume that certain types of adverbial phrases are in some sense dependent on the verb); we leave this problem for future research.

Third, the fact that stranding and pied piping are (normally) in complementary distribution requires us to assume that one of the two is the preferred option. This can be formulated as the constraint in (153), which can be seen as a slightly more precise version of the hypothesis put forward in Subsection VA that pied piping should be regarded as a repair strategy. This fully accounts for the acceptability judgments on stranding and pied piping in the examples in (144), (145) and (147).

- (153) **Avoid pied piping:** strand as much material as possible.

The set of claims in (151)-(153) also provides an account for the acceptability judgments on the circumpositional cases in (148)-(150). Consider again the examples in (148b&c), repeated as (154) in a form consistent with the hypothesis in (151c), according to which PP<sub>2</sub> is the complement of PP<sub>1</sub>.

- (154) a. \*Wie<sub>i</sub> sprong Jan [<sub>PP1</sub> [<sub>PP2</sub> over *t<sub>i</sub>*] heen]?  
 who jumped Jan over HEEN  
 ‘Who did Jan jump over?’  
 b. Waar<sub>i</sub> sprong Jan [<sub>PP1</sub> [<sub>PP2</sub> *t<sub>i</sub>* over] heen]?  
 where jumped Jan over HEEN  
 ‘What did Jan jump over?’

That *wh*-movement of the pronoun *wie* cannot strand the circumposition in (154a) follows immediately from clause (152a): the preposition *over* precedes the pronoun and can therefore not be stranded. Clause (152a) does not prohibit R-extraction, as the preposition *over* follows its complement in pronominal PPs. R-extraction is also allowed by clause (152b): PP<sub>1</sub> is selected by the head of PP<sub>2</sub>, which in its turn is selected by the main verb.

Now, consider again the examples in (149), repeated here in a slightly different form as (155). Example (155b) is predicted to be acceptable because *wh*-movement of PP<sub>2</sub> is in accordance with both clauses in (152): PP<sub>1</sub> is selected by the main verb and the head of PP<sub>1</sub>, *heen*, follows its complement, PP<sub>2</sub>. Since we have already seen that the head of PP<sub>2</sub>, *over*, cannot be stranded, pied piping is allowed by the constraint “avoid pied piping” in (153). Example (155a), on the other hand, is blocked by this constraint, as (155b) pied-pipes less material.

- (155) a. <sup>\*?</sup>[<sub>PP1</sub> [<sub>PP2</sub> Over wie] heen]<sub>i</sub> sprong Jan *t<sub>i</sub>*?  
           over who HEEN jumped Jan  
       b. [<sub>PP2</sub> Over wie]<sub>i</sub> sprong Jan [<sub>PP1</sub> *t<sub>i</sub>* heen]?  
           over who jumped Jan HEEN  
           ‘Who did Jan jump over?’

Now, consider again the examples in (150), repeated here in a slightly different form as (156a&b). The descriptive generalization in (152) allows the structure in (156b) for the same reason as it allows the structure in (155b). The unacceptability of this structure must therefore be due to the constraint “avoid pied piping” in (153). And this is indeed the case: example (154b), repeated here as (156c), is the preferred structure, as it involves less pied-piped material.

- (156) a. <sup>\*?</sup>[<sub>PP1</sub> [<sub>PP2</sub> Waar over] heen]<sub>i</sub> sprong Jan *t<sub>i</sub>*?  
           where over HEEN jumped Jan  
       b. <sup>\*?</sup>[<sub>PP2</sub> Waar over]<sub>i</sub> sprong Jan [<sub>PP1</sub> *t<sub>i</sub>* heen]?  
           where over jumped Jan HEEN  
       c. Waar<sub>i</sub> sprong Jan [<sub>PP1</sub> [<sub>PP2</sub> *t<sub>i</sub>* over] heen]?  
           where jumped Jan over HEEN

This account of the surprising acceptability contrast between (155b) and (156b) completes our description of the acceptability judgment on pied piping/stranding in examples like (144)-(150), in which the *wh*-element is the complement of an adpositional phrase. The next subsection continues with a discussion of PPs stranded by *wh*-movement of their modifier.

### 5. Modifier of PP

Modification of PPs is normally restricted to spatial en temporal PPs. The following discussion of the movement behavior of these modifiers under *wh*-movement will be relatively brief because a more extensive discussion can be found in Sections P3.1 and P3.2. Here we will show that stranding/pied piping is sensitive to the syntactic function of the PPs: while the heads of complementive PPs are normally stranded, the heads of adverbial PPs are pied-piped. Prepositional objects like *op vader* in *Jan wacht op vader* ‘Jan is waiting for father’ are not relevant, as these do not allow modification.

Section P3.1.2 has shown that modifiers of spatial PPs are normally of two kinds: modifiers of orientation like *recht* ‘straight’ in (157a) and modifiers of distance like the adjectival phase *diep*

- (157) a. Jan staat [<sub>PP</sub> recht voor de camera].  
           Jan stands straight in.front.of the camera  
           ‘Jan is standing straight in front of the camera.’  
       b. De olie zit [<sub>PP</sub> diep in de grond].  
           the oil sits deep in the ground  
           ‘The oil is deep in the ground.’

The two types of modifier exhibit different behavior when it comes to modification: modifiers of orientation are modified by approximative modifiers like *zowat* ‘approximately/more or less’ and by *precies* ‘exactly’, while adjectival modifiers of

distance are modified by degree modifiers like *erg/heel* ‘very’.

- (158) a. Jan staat [<sub>PP</sub> zowat/precies recht voor de camera].  
 Jan stands approximately/exactly straight in front of the camera  
 ‘Jan is standing more or less/straight in front of the camera.’
- b. De olie zit [<sub>PP</sub> erg/heel diep in de grond].  
 the oil sits very/very deep in the ground  
 ‘The oil is very deep in the ground.’

It seems that approximative modifiers such as *recht* ‘straight’ do not have an interrogative counterpart. The string *Hoe recht staat Jan voor de camera?* is fully acceptable but does not have the intended interpretation: the phrase *wh*-phrase *hoe recht* does not pertain to the location of Jan with respect to the camera, but to his posture; cf. P3.1.2. This means that the structure in (159a) is unacceptable. Degree modifiers such as *diep* ‘deep’, on the other hand, do have an interrogative counterpart; the (b)-examples are acceptable with the intended interpretation.

- (159) a. \*Hoe recht<sub>i</sub> staat Jan [<sub>PP</sub> *t*<sub>i</sub> voor de camera]?  
 how straight stands Jan in front of the camera
- b. Hoe diep<sub>i</sub> zit de olie [<sub>PP</sub> *t*<sub>i</sub> in de grond]?  
 how deep sits the oil in the ground  
 ‘How deep is the oil in the ground?’
- b’. [<sub>PP</sub> Hoe diep in de grond]<sub>i</sub> zit de olie *t*<sub>i</sub>?  
 how deep in the ground sits the oil  
 ‘How deep is the oil in the ground?’

Given the option of stranding in (159b), the constraint “avoid pied piping” in (153) predicts example (159b’) to be ungrammatical, but nevertheless most of our informants do accept examples of this type. It seems, however, that actual usage is more in line with “avoid pied piping”. A Google search (6/26/2014) on the string [*Hoe diep in de grond zit*] resulted in no more than one relevant hit, whereas [*Hoe diep zit \*in de grond*] resulted in 13 relevant hits; in our search we excluded examples containing the string [*tot hoe*] and checked the remaining results manually.

Example (160a) shows that spatial PPs can also be modified by nominal measure phrases such as *2 kilometer*. Such nominal measure phrases can also be interrogative and again it seems that stranding and pied piping both give rise to acceptable results; cf. Corver (1990:ch.9). Since it is not readily possible by means of a simple Google search to investigate whether actual usage is more in line with the constraint “avoid pied piping”, we leave this issue to future research.

- (160) a. De olie zit [<sub>PP</sub> 2 kilometer onder de grond].  
 the oil sits 2 kilometer under the ground  
 ‘The oil is located 2 kilometers under the surface.’
- b. Hoeveel kilometer<sub>i</sub> zit de olie [<sub>PP</sub> *t*<sub>i</sub> onder de grond]?  
 how many kilometers sits the oil under the ground  
 ‘How many kilometers is the oil under the surface?’
- b’. [<sub>PP</sub> Hoeveel kilometer onder de grond]<sub>i</sub> zit de olie *t*<sub>i</sub>?  
 how many kilometers under the ground sits the oil  
 ‘How many kilometers is the oil under the surface?’

In all examples above the spatial PPs function as complementives. If the spatial PP functions as an adverbial phrase, pied piping is obligatory. This is illustrated in the examples in (161) and (162) for adjectival degree modifiers and nominal measure phrases, respectively.

- (161) a. De speleoloog verongelukte [<sub>PP</sub> diep onder de grond].  
the speleologist was.killed deep under the ground  
‘The speleologist had a fatal accident deep underground.’
- b. \*Hoe diep<sub>i</sub> verongelukte de speleoloog [<sub>PP</sub> *t<sub>i</sub>* onder de grond]?  
how deep was.killed the speleologist under the ground
- b’. [<sub>PP</sub> Hoe diep onder de grond]<sub>i</sub> verongelukte de speleoloog?  
how deep under the ground was.killed the speleologist  
‘How deep underground did the speleologist have a fatal accident?’
- (162) a. De speleoloog verongelukte [<sub>PP</sub> 80 meter onder de grond].  
the speleologist was.killed 80 meter under the ground  
‘The speleologist had a fatal accident 80 meters underground.’
- b. \*Hoeveel meter<sub>i</sub> verongelukte de speleoloog [<sub>PP</sub> *t<sub>i</sub>* onder de grond]?  
how many meter was.killed the speleologist under the ground
- b’. [<sub>PP</sub> Hoeveel meter onder de grond]<sub>i</sub> verongelukte de speleoloog?  
how many meter under the ground was.killed the speleologist  
‘How many meters underground did the speleologist have a fatal accident?’

Temporal PPs are normally used as adverbial phrases and the (b)-examples in (163) show that in such cases *wh*-movement triggers pied piping. This finding was confirmed by our Google searches (7/2/2014) on the search strings [*hoe lang na*] and [*hoe lang \* na*]: the first search string resulted in nearly 200 hits, most of which instantiated the relevant construction, whereas a cursory look at the first 100 results for the second search string showed that *hoe lang* and the *na*-PP must be construed as independent adverbial phrases when they are not adjacent.

- (163) a. De speleoloog overleed [<sub>PP</sub> kort na het ongeval].  
the speleologist died shortly after the accident  
‘The speleologist died shortly after the accident.’
- b. \*Hoe lang<sub>i</sub> overleed de speleoloog [<sub>PP</sub> *t<sub>i</sub>* na het ongeval]?  
how long died the speleologist after the accident
- b’. [<sub>PP</sub> Hoe lang na het ongeval]<sub>i</sub> overleed de speleoloog?  
how long after the accident died the speleologist  
‘How long after the accident did the speleologist die?’

The discussion above has shown that *wh*-movement of a modifier may strand a PP used as a complement but not as an adverbial, which is in line with our discussion in Section 11.3.1.3 that adverbial phrases are normally islands for extraction. We further found that the (b)-examples in (159) and (160) constitute potential problems for the constraint “avoid pied piping” in (153), although the results of a Google search suggests that actual usage may be more in line with this constraint. For more discussion of (*wh*-movement of) adjectival and nominal modifiers of PPs, we refer the reader to Chapter P3.

*B. Wh-extraction from noun phrases*

This subsection can be brief because there is little to add to what has been said in Subsection VB; we will confine ourselves to repeating some of the main findings. First, we saw that pied piping is obligatory if the *wh*-phrase is prenominal such as a demonstrative or a possessive pronoun. One example is repeated here as (164).

- (164) Welk/Wiens <boek> heeft Marie <\*boek> gelezen?  
 which/whose book has Marie read  
 ‘Which/Whose book has Marie read?’

This leaves us with postnominal PPs like the possessive PP *van Peter* in (165a). Example (165b) shows that such examples are different from examples like (164) in that pied piping is excluded, and example (165b') furthermore suggests that, in accordance with the constraint “avoid pied piping” in (153), stranding is possible.

- (165) a. Marie heeft [de auto [van Peter<sub>poss.</sub>]] geleend.  
 Marie has the car of Peter borrowed  
 ‘Marie has borrowed up Peter’s car.’  
 b. \*[De auto [van wie<sub>poss.</sub>]] heeft Marie geleend?  
 the car of who has Marie borrowed  
 b'. Van wie heeft Marie de auto geleend?  
 of who has Marie the car borrowed

Things are, however, more complicated than this. The examples in (166) show that the *van*-PP in (165b') need not be construed as the possessor of the noun phrase, but may also be analyzed as an indirect object (source). First, (166a) shows that the interrogative *van*-PP can also be used if the possessor is expressed by a possessive pronoun, which makes it very unlikely that the *van*-PP functions as a possessor: cf. \*[*zijn auto van Peter*] ‘lit.: his car of Peter’. Second, (166b) shows that the direct object can be pronominalized without affecting the *van*-PP, whereas pronominalization normally affects all noun phrase internal elements.

- (166) a. Van wie heeft Marie zijn<sub>poss</sub> auto geleend?  
 of who has Marie his car borrowed  
 ‘From whom did Marie borrow his car?’  
 b. Van wie heeft Marie hem geleend?  
 of who has Marie him borrowed  
 ‘From whom did Marie borrow it?’

Subsection VB has shown further that it is very hard (if not impossible) to construct cases that do not allow some alternative analysis; *wh*-moved *van*- and *voor*-PPs, for example, can in many cases plausibly be analyzed as restrictive adverbial phrases; see also N2.2.1.5, sub III. Finally, it was shown that in many cases postnominal PPs cannot be extracted; one case illustrating this ban on stranding of the noun phrase is repeated in (167b). Example (167b') is added to show that pied piping is likewise excluded, which means that the intended question can simply not be phrased.

- (167) a. Els zal morgen [haar klacht [tegen Peter]] intrekken.  
 Els will tomorrow her complaint against Peter withdraw  
 ‘Els will withdraw her complaint against Peter tomorrow.’



- b. \*[Tegen wie]<sub>i</sub> zal Els [haar klacht *t*<sub>i</sub>] morgen intrekken?  
 against who will Els her complaint tomorrow withdraw
- b'. \*[Haar klacht [tegen wie]]<sub>i</sub> zal Els morgen *t*<sub>i</sub> intrekken?  
 her complaint against who will Els tomorrow withdraw

The above suggests that noun phrases are absolute islands for *wh*-extraction, although more research is needed to establish this firmly; a similar claim was made earlier by Horn (1974), Bach & Horn (1976), Koster (1978:81) and, at least for definite noun phrases, by Fiengo & Higginbotham (1981). Subsection VII will return to this issue and discuss one possible counterexample, the so-called *wat voor* split.

### C. *Wh*-extraction from APs

This subsection is again relatively brief given that much of what will be said here is discussed more extensively in Sections A2.3 and A3.1.4. We start by showing that *wh*-movement of a prepositional/nominal complement of an AP normally does not trigger pied piping. The result of *wh*-movement of the modifier of an AP depends on the nature of the modifier: some trigger pied piping whereas others are compatible with stranding.

#### 1. *PP*-complements

Section A2.1 has shown that adjectives typically select a PP as their complement. Although such complements can normally either precede or follow the adjective, their base-position is the one following the adjective. There are at least three arguments in favor of the claim that the pre-adjectival position of prepositional complements is normally derived by leftward movement. We will illustrate this here by means of the examples in (168), in which the adjective *boos* 'angry' selects an *over*-PP as its complement. First, (168a) shows that the *over*-PP cannot be placed between the modifier *erg* 'very' and the adjective *boos*; given that complements are normally generated closer to the selecting head than modifiers, this would be unexpected if the *voor*-PP were base-generated in pre-adjectival position. Second, the °freezing principle requires that stranded prepositions occupy their base-position; the fact that the stranded preposition *over* cannot precede the adjective in (168b) therefore shows that the PP originates in post-adjectival position. Finally, the (c)-examples show that topicalization of the full AP is not possible if the PP-complement precedes the adjective; this strongly suggests that the PP is external to the AP if it is in pre-adjectival position.

- (168) a. Jan is <over die opmerking> erg boos <over die opmerking>.  
 Jan is about that remark very angry  
 'Jan is angry about that remark.'
- b. Jan is *er* nog <\*over> erg boos <over>.  
 Jan is there still about very angry  
 'Jan is still angry about it.'
- c. Erg boos over die opmerking is Jan niet.  
 very angry about that remark is Jan not
- c'. \*Over die opmerking erg boos is Jan niet.  
 about that remark very angry is Jan not



Example (168a) suggests that the *over*-PP can be moved out of the AP into a landing site in the middle field of the clause, which is supported by the fact that the PP can be separated from the AP by a clausal adverb: cf. *Jan is over die opmerking waarschijnlijk erg boos* ‘Jan is probably very angry about that remark’. It therefore need not surprise us that the PP can also be *wh*-moved in isolation; cf. (169a). Example (169b) in fact shows that pied piping of the full AP leads to a degraded result, which is, of course, predicted by the constraint “avoid pied piping” in (153).

- (169) a. Over welke opmerking is Jan [boos  $t_i$ ]?  
 about which remark is Jan angry  
 ‘About which remark is Jan angry?’  
 b. ??[Boos over welke opmerking]<sub>i</sub> is Jan  $t_i$ ?  
 angry about which remark is Jan

For more extensive discussion of leftward movement of prepositional complements of adjectives, we refer the reader to Section A2.3.1, which also discusses a number of potentially problematic cases for the brief sketch given here.

## 2. Nominal complements

Section A2.2 has shown that certain adjectives are able to take a nominal argument; cf. Van Riemsdijk (1983). Two examples are given in (170). We added German examples in order to show that the case of the nominal argument depends on the adjective not on the copular verb; *zat/überdrüssig* ‘fed up’ select genitive, while *vertrouwd/geläufig* select dative case. Case assignment thus shows that the nominal object is an argument of the adjective (and not of the verb).

- (170) a. Peter is deze opera zat. [Dutch]  
 Peter is this opera fed.up  
 a'. Peter ist dieser Oper<sub>genitive</sub> überdrüssig. [German]  
 Peter is this opera fed.up  
 ‘Peter is fed up with this opera.’  
 b. Deze omgeving is hem erg vertrouwd. [Dutch]  
 this area is him very familiar  
 b'. Diese Umgebung ist ihm<sub>dative</sub> sehr geläufig. [German]  
 this area is him very familiar  
 ‘This area is very familiar to him.’

A potential problem with these cases is that the regular °constituency tests do not show that the adjective and the genitive/dative noun phrase form a constituent; cf. Section A2.3.2. It is for instance awkward to place them into sentence-initial position together; judgments differ from case to case and from speaker to speaker, but examples like (171a&b) are generally considered degraded. The primed examples show that the noun phrase and the adjective can both be topicalized in isolation.

- (171) a. % [Deze opera zat]<sub>i</sub> is Peter nog niet  $t_i$ .  
 this opera fed.up is Peter yet not  
 ‘Peter is not yet fed up with this opera.’  
 a'. Deze opera is Peter nog niet zat.  
 a''. Zat is Peter deze opera nog niet.

- b. <sup>%</sup>[Hem vertrouwd]<sub>i</sub> is deze omgeving nog niet <sub>t<sub>i</sub></sub>.  
 him familiar is this area still not  
 ‘This area is not yet familiar to him.’  
 b’. Hem is deze omgeving nog niet vertrouwd.  
 b’’. Deze omgeving is hem nog niet vertrouwd.

The questionable acceptability of the primeless examples suggests that, for some unknown reason, the nominal argument *must* be moved leftward into some AP-external position. This is in fact also suggested by the fact that the nominal complement of the adjective must precede the modifier *erg* ‘very’ in the examples in (172) and can even be separated from the AP by a clausal adverb such as *waarschijnlijk* ‘probably’: cf. Cinque (1993:252).

- (172) a. Peter is <deze opera> erg <\*deze opera> zat.  
 Peter is this opera very fed.up  
 ‘Peter is very fed up with of this opera.’  
 a’. Peter is deze opera waarschijnlijk zat.  
 Peter is this opera probably fed.up  
 ‘He is probably fed up with this opera.’  
 b. Deze omgeving is <hem> erg <\*hem> vertrouwd.  
 this area is him very familiar  
 ‘This area is very familiar to him.’  
 b’. Deze omgeving is hem waarschijnlijk vertrouwd.  
 this area is him probably familiar  
 ‘This area is probably familiar to him.’

Given the discussion above it will not come as a surprise that *wh*-movement of the nominal argument cannot pied-pipe the adjective.

- (173) a. Welke opera ben je zat? [stranding]  
 which opera are you fed.up  
 ‘Which opera are you fed up with?’  
 a’. \*Welke opera zat ben je? [pied piping]  
 b. Wie is deze omgeving nog niet vertrouwd? [stranding]  
 who is this area yet not familiar  
 ‘To whom is this area not yet familiar?’  
 b’. \*Wie vertrouwd is deze omgeving nog niet? [pied piping]

For completeness’ sake, we add the examples in (174) to show that *wh*-movement of the (modified) adjectives *hoe zat/bekend* themselves strands the nominal argument.

- (174) a. Hoe zat ben je deze opera? [stranding]  
 how fed.up are you this opera  
 ‘How fed up are you with this opera?’  
 a’. \*Deze opera hoe zat ben je? [pied piping]  
 b. Hoe vertrouwd is deze omgeving jou? [stranding]  
 how familiar is the area you  
 ‘How familiar is this area to you?’  
 b’. \*Jou hoe vertrouwd is deze omgeving? [pied piping]

3. *Modifiers*

The (a)-examples show that *wh*-movement of the interrogative degree modifier *hoe* ‘how’ obligatorily pied-pipes the AP; stranding of the adjectival head leads to a severely degraded result.

- (175) a. Jan is erg verslaafd.  
 Jan is very addicted
- b. [Hoe verslaafd]<sub>i</sub> is Jan *t*<sub>i</sub>? [pied piping]  
 how addicted is Jan
- b'. \*Hoe<sub>i</sub> is Jan [*t*<sub>i</sub> verslaafd]? [stranding]  
 how is Jan addicted

Things are different, however, if the adjective is modified by a gradable degree adverb. The interrogative counterpart of (176) is compatible both with pied piping and stranding although the latter seems to be somewhat preferred (but judgments seem to differ from case to case and from speaker to speaker); cf. Section A3.1.2.4.

- (176) a. Jan is zwaar verslaafd.  
 Jan is heavily addicted  
 ‘Jan is severely addicted.’
- b. ?[Hoe zwaar verslaafd]<sub>i</sub> is Jan *t*<sub>i</sub>? [pied piping]  
 how heavily addicted is Jan
- b'. Hoe zwaar<sub>i</sub> is Jan [*t*<sub>i</sub> verslaafd]? [stranding]  
 how heavily is Jan addicted  
 ‘How severely addicted is Jan?’

A similar contrast can be found in the case of nominal modifiers, although there is a slight complication in this case. First, consider the examples in (177), which show that pied piping is obligatory if the measure adjective *lang* ‘long’ is modified by the interrogative degree modifier *hoe* ‘how’.

- (177) a. Het zwembad is erg lang.  
 the pool is very long
- b. [Hoe lang]<sub>i</sub> is het zwembad *t*<sub>i</sub>? [pied piping]  
 how long is the pool
- b'. \*Hoe is het zwembad [*t*<sub>i</sub> lang]? [stranding]  
 how is the pool long

Example (178a) shows that measure adjectives like *lang* can also be modified by a noun phrase. The (b)-examples show that in this case stranding gives rise to a marked but acceptable result; judgments again seem to differ from case to case and from speaker to speaker.

- (178) a. Het zwembad is [100 meter lang].  
 the pool is 100 meter long  
 ‘The pool is 100 meters long.’
- b. ??[Hoeveel meter lang]<sub>i</sub> is het zwembad *t*<sub>i</sub>? [pied piping]  
 how.many meters long is the pool
- b'. ?Hoeveel meter is het zwembad [*t*<sub>i</sub> lang]? [stranding]  
 how.many meter is the pool long

The markedness of (178) is probably of a non-syntactic nature; it may be an instance of blocking, due to the fact that the intended question can be more economically expressed by means of example (177b). That we are not dealing with a syntactic restriction is clear from the fact that nominal modifiers of the type in (178) can also be used in examples like (179), where the degree modifier *te* ‘too’ blocks the use of the interrogative degree modifier *hoe* ‘how’. This means that syntactic blocking does not apply in this case and the result in (179b’) is indeed fully acceptable. For more discussion of the behavior of modifiers of measure adjectives like *lang* ‘long’ in (178) and (179), we refer the reader to Section A3.1.4.2.

- (179) a. Het zwembad is [5 centimeter te lang].  
the pool is 5 centimeter too long  
‘The pool is 5 centimeters too long.’
- b. <sup>??</sup>[Hoeveel centimeter te lang]<sub>i</sub> is het zwembad *t*<sub>i</sub>? [pied piping]  
how.many centimeter too long is the pool
- b’. Hoeveel centimeter is het zwembad [*t*<sub>i</sub> te lang]? [stranding]  
how.many centimeter is the pool too long

The examples above have shown that *wh*-movement of simplex modifiers like *hoe* ‘how’ obligatorily pied-pipe the full AP. *Wh*-movement of more complex modifiers like *hoe zwaar* ‘how heavily’ in (176), *hoe lang* ‘how long’ in (177) and *hoeveel (centi)meter* ‘how many centimeters’ do allow stranding. The fact that pied piping is allowed as a marked option alongside stranding is again a potential problem for the constraint “avoid pied piping” in (153).

### VII. A note on the avoidance of pied piping

Subsection VI has shown that, depending on various factors, *wh*-movement of a subpart of a clausal constituent may involve pied piping of the full clausal constituent or stranding of its non-interrogative part. The two options are normally in complementary distribution, which was formally accounted for by means of the constraint “avoid pied piping” in (153). We have seen, however, that there are also a number of potential problems for this constraint. We suggested that in at least some of these problematic cases, pied piping is a marked/disfavored option, in accordance with what one might expect on the basis of the “avoid pied piping” constraint, although it should be added that it is still an open question whether this claim will stand further scrutiny. This subsection adds one problem for the “avoid pied piping” constraint that seems uncontroversial: the pied piping/stranding behavior of so-called *wat voor*-phrases. Since the relevant data are extensively discussed in Section N4.2.2.3, we will illustrate the problem by means of direct objects only. The examples in (180) show that *wat voor*-phrases freely allow both options.

- (180) a. [Wat voor een boeken]<sub>i</sub> heeft Peter *t*<sub>i</sub> gekocht? [pied piping]  
what for a books has Peter bought  
‘What kind of books has Peter bought?’
- b. Wat<sub>i</sub> heeft Peter [*t*<sub>i</sub> voor een boeken] gekocht? [stranding/*wat voor* split]  
what has Peter for a books bought  
‘What kind of books has Peter bought?’

One way out would be to assume that the two options express different meanings or obey different conditions on their actual use, in which case one might assume that the constraint “avoid pied piping” can be overridden by certain considerations of meaning/actual usage. However, to our knowledge this has never been claimed to be the case. This suggests that “avoid pied piping” is not a hard and fast rule; future research should investigate what other factors may affect its application.

### 11.3.1.2. *Wh-extraction from embedded clauses (long wh-movement)*

This section discusses a special case of *wh*-extraction, which we will refer to as LONG *wh*-MOVEMENT. This type of *wh*-movement is special in that it is apparently unbounded: it may cross an in principle indefinite number of clausal boundaries (although in actual fact the number is of course limited for practical reasons). We illustrate this in (181): in (181a) and (181b) *wh*-movement crosses, respectively, one and two clausal boundaries.

- (181) a. Wat<sub>i</sub> zegt Marie [dat Peter *t*<sub>i</sub> gekocht heeft]?  
 what says Marie that Peter bought has  
 ‘What does Marie say that Peter has bought?’
- b. Wat<sub>i</sub> denkt Jan [dat Marie zegt [dat Peter *t*<sub>i</sub> gekocht heeft]]?  
 what think Jan that Marie says that Peter bought has  
 ‘What do you think that Marie says that Peter has bought?’

Long-distance dependencies of the type in (181) apparently go against the general finding in generative grammar that syntactic dependencies are local, which can normally be taken to mean at least “clause-bound”. There is, however, reason for assuming that *wh*-movement in (181) does not apply in one fell swoop, but in a so-called cyclic fashion; see Chomsky (1973), and Boeckx (2008) for a more recent discussion. The derivation thus proceeds as indicated in (182): the *wh*-phrase *wat* is first moved into the initial position of its own clause (the first cycle), from where it is subsequently moved on into the clause-initial position of the next higher clause (the second cycle), etc. The primed traces in (182) indicate all intermediate landing sites of the *wh*-phrase and show that all individual movements are local, provided that we assume that the initial position of a clause functions as an “escape hatch” for the *wh*-phrase.

- (182) a. Wat<sub>i</sub> zegt Marie [*t'*<sub>i</sub> dat Peter *t*<sub>i</sub> gekocht heeft]?  
 what says Marie that Peter bought has  
 ‘What does Marie say that Peter has bought?’
- b. Wat<sub>i</sub> denkt Jan [*t''*<sub>i</sub> dat Marie zegt [*t'*<sub>i</sub> dat Peter *t*<sub>i</sub> gekocht heeft]]?  
 what thinks Jan that Marie says that Peter bought has  
 ‘What do you think that Marie says that Peter has bought?’

Despite the fact that long *wh*-movement can be broken up in smaller, local movement steps, we will follow general practice in using the notion of long *wh*-movement as a convenient descriptive term for *wh*-extraction from embedded clauses. For convenience, we will often omit the intermediate (primed) traces from our structural representations if they are not relevant for our discussion.

Long *wh*-movement is a severely restricted phenomenon subject to various stringent conditions. Subsection I starts by showing that this does not hold for the *wh*-moved phrase itself: the same set of elements allowing local *wh*-movement may undergo long *wh*-movement. If long *wh*-movement consists of a sequence of local movement steps, this is of course expected. Subsection II will show, however, that there are some more or less concealed issues with long *wh*-movement of subjects, which are related to the so-called °complementizer-trace filter. Subsections III and IV continue to show that there are constraints on the embedded clause from which *wh*-movement takes place as well as the matrix verb. Subsection V provides a brief comparison of long *wh*-movement with other strategies to establish “long” *wh*-dependencies, which can be found in certain dialects of Dutch as well as German. Since Subsections I-V are only concerned with finite clauses, Subsection VI concludes with a discussion of long *wh*-movement from infinitival clauses; such cases have received much less attention in the literature, but are interesting in their own right because they have a number of special properties.

*I. Restrictions on the moved element*

Long *wh*-movement does not seem to differ from local *wh*-movement when it comes to the syntactic functions of the moved elements. The examples in (183) show that it may affect clausal constituents of all types: argument, complementive and adjunct. Just as in the case of local *wh*-movement, the only requirement seems to be that an interrogative form is available. Recall that we will leave out the intermediate trace in the clause-initial position of the embedded clause if this is not immediately relevant for our discussion. Note that the *wh*-phrase *wanneer* ‘when’ in (183d) can also be construed as a modifier of the matrix-clause, but this is of course not the reading intended here.

- (183) a. *Wie<sub>i</sub> zei/dacht je [dat t<sub>i</sub> dat boek gekocht had]? [subject]*  
 who said/thought you that that book bought has  
 ‘Who did you say/think had bought that book.’
- b. *Wat<sub>i</sub> zei/dacht je [dat Peter t<sub>i</sub> gekocht heeft]? [object]*  
 what said/thought you that Peter bought has  
 ‘What did you say/think that Peter has bought?’
- c. *Hoe oud<sub>i</sub> zei/dacht je [dat dit fossiel t<sub>i</sub> was]? [complementive]*  
 how old said/thought you that this fossil was  
 ‘How old did you say/think that this fossil was?’
- d. *Wanneer<sub>i</sub> zei/dacht je [dat Peter t<sub>i</sub> vertrokken was]? [adjunct]*  
 when said/thought you that Peter left had  
 ‘When do you say/think that Peter had left?’

The examples in (184) further show that long *wh*-movement is not confined to clausal constituents but may also be applied to *wh*-elements embedded in clausal constituents (provided that local *wh*-movement also allows stranding). We illustrate this in (184) by means of, respectively, an interrogative modifier of an adjectival complementive and a split *wat voor*-phrase in (184b).

- (184) a. Hoe zwaar<sub>i</sub> denk je [dat Jan [<sub>AP</sub> t<sub>i</sub> verslaafd] is]?  
 how heavily think you that Jan addicted is  
 ‘How severely addicted do you think that Jan is?’  
 b. Wat<sub>i</sub> denk je [dat Peter [<sub>NP</sub> t<sub>i</sub> voor een boeken] gekocht heeft]?  
 what think you that Peter for a books bought has  
 ‘What kind of books do you think that Peter has bought?’

## II. Complementizer-trace effects

The examples discussed in the previous subsection suggest that long *wh*-movement does not impose any special conditions on the syntactic function of the moved element. It is nevertheless necessary to say more about long *wh*-movement of subjects given that it triggers special effects in various languages. This is illustrated for English in the examples in (185), which show that long *wh*-movement of subjects but not of objects requires omission of the complementizer *that*. Chomsky & Lasnik (1977) exclude the configuration [... [<sub>C</sub> that] t<sub>i</sub> ...] by means of the so-called *that*-trace filter, but since it is possible to find similar facts in languages other than English, we will use the more general term complementizer-trace filter.

- (185) a. Who<sub>i</sub> do you think [(*\*that*) t<sub>i</sub> will read the letter]? [subject]  
 b. What<sub>i</sub> do you think [(*that*) John will do t<sub>i</sub>]? [object]

Long *wh*-movement of subjects also triggers a special effect in French. The translation of (185a) in (186a) shows that the subject trace cannot occur if the declarative complementizer appears in its regular form, *que*, but requires it to surface as *qui*; cf. Kayne (1976). Example (186b) further shows that this *que/qui* alternation does not apply in the case of long *wh*-movement of, e.g., an object.

- (186) a. Qui<sub>i</sub> crois-tu [qui/*\*que* t<sub>i</sub> lira la lettre]? [subject]  
 who think-you that/*that* read<sub>future</sub> the letter  
 ‘Who do you think will read the letter?’  
 b. Que<sub>i</sub> crois-tu [que/*\*qui* Jean fera t<sub>i</sub>]? [object]  
 what think-you that/*that* Jean do<sub>future</sub>  
 ‘What do you think that Jean will do?’

The Dutch translations of the examples in (185)/(186) in the primeless examples in (187) suggest that the subject-object asymmetry found in English and French does not occur in Standard Dutch, as they are both fully acceptable; cf. Dekkers (1999). It seems that for at least some speakers the question as to whether the subject-object asymmetry shows up depends on the type of interrogative noun phrase: while non-D-linked subject pronouns such as *wie* ‘who’ in (187a) easily allow long *wh*-movement without any special ado, °D-linked subjects such as *welke jongen* ‘which boy’ in (187a’) are marked (but certainly not ungrammatical) for such speakers.

- (187) a. Wie<sub>i</sub> denk je [dat t<sub>i</sub> de brief zal lezen]? [subject]  
 who think you that the letter will read  
 ‘Who do you think will read the letter?’  
 a’. <sup>?</sup>Welke jongen<sub>i</sub> denk je [dat t<sub>i</sub> de brief zal lezen]? [subject]  
 which boy think you that the letter will read  
 ‘Which boy do you think will read the letter?’



- b. Wat<sub>i</sub> denk je [dat Jan t<sub>i</sub> zal doen]? [object]  
 what think you that Jan will do  
 ‘What do you think that Jan will do?’

A possible reason for the difference in acceptability of the two (a)-examples may be that, despite appearances, the traces of the two *wh*-phrases do not occupy the same position in the clause. We will first illustrate the difference in location by means of the examples in (188) and (189) without a definite object. The examples in (188) show that long *wh*-movement of *wie* requires the presence of the expletive *er* ‘there’; long *wh*-movement of *welke jongen* is severely degraded if *er* is not present and again marked for some speakers with *er* present.

- (188) a. Wie<sub>i</sub> denk je [dat \*(er) t<sub>i</sub> gelogen heeft]?  
 who think you that there lied has  
 ‘Who do you think has lied?’  
 b. Welke jongen<sub>i</sub> denk je [dat \*(<sup>?</sup>er) t<sub>i</sub> gelogen heeft]?  
 which boy think you that there lied has  
 ‘Which boy do you think has lied?’

What is crucial for our argument is not so much the admittedly subtle effect of D-linking on the acceptability of an overt expletive in the two examples in (188), but the contrast between the examples in (188) and those in (189); while omission of the expletive is completely excluded in (188), it is (at least marginally) allowed in (189).

- (189) a. Wie heeft <sup>?</sup>(er) gelogen?  
 who has there lied  
 ‘Who has lied?’  
 b. Welke jongen heeft (<sup>?</sup>er) gelogen?  
 which boy has there lied  
 ‘Which boy has lied?’

The acceptability contrasts indicated in (188) and (189) can be accounted for by appealing to the complementizer-trace filter. First consider the two (a)-examples. Since the expletive *er* is right-adjacent to the declarative complementizer *dat* in (188) or the finite verb in non-subject-initial clauses such as *Gisteren heeft er iemand gelogen* ‘Yesterday someone lied’, it can be assumed to occupy the regular subject position. If we further assume that absence of the expletive indicates that the subject has been moved into the regular subject position (a marked option for non-D-linked *wie*), the acceptability difference between the two (a)-examples follows from the complementizer-trace filter: if the expletive *er* is not present, the C-position is immediately followed by a *wh*-trace, which is prohibited if the C-position is filled by the complementizer *dat* but allowed if it is filled by the finite verb. The contrast is even clearer in the case of the two (b)-examples, due to the fact signaled by the markedness of *er* that D-linked *wh*-phrases are preferably *wh*-moved via the regular subject position.

Let us now return to the contrast between (187a) and (187a’). At first sight, the proposal above does not seem to help much to account for this, as these examples do not contain the expletive *er*. If this indicates, as suggested above, that the subject



has been *wh*-moved via the regular subject position, we would predict these examples to be both unacceptable, contrary to fact. However, the fact that the expletive is not realized is not due to the position of the subject but to yet another factor, which was discussed in Section N8.1.4, namely that the realization of expletives is not only sensitive to the (in)definiteness of the subject, but also depends on the presence of presuppositional material in the clause. Consider the examples in (190), in which the subjects are all interpreted as non-specific indefinites, and in which *er* should not be construed spatially (“there”) but as a pure expletive.

- (190) a. dat <sup>?</sup>(er) iemand een boek gekocht heeft.  
 that there someone a book bought has  
 b. dat (<sup>?</sup>er) iemand het boek gekocht heeft.  
 that there someone the book bought has  
 c. dat (\*er) iemand het gekocht heeft.  
 that there someone it bought has

The contrast between the two examples in (190a&b) shows that the definiteness of the object may affect the distribution of the expletive *er*. This is even clearer in (190c), where the referential personal pronoun *het* blocks realization of the expletive. Consequently, in order to show that the acceptability of long *wh*-movement of the subject depends on D-linking, we also have to control for the definiteness of the object. This has been done in the examples in (191), which show that with an indefinite object omission of the expletive again has a severely degrading effect in the case of long but not in the case of local *wh*-movement. The contrast between the primeless and primed examples (191) thus shows again that *wh*-movement of subjects is sensitive to the complementizer-trace filter.

- (191) a. Wie<sub>i</sub> denk je [dat <sup>\*?</sup>(er) t<sub>i</sub> een boek gekocht heeft]?  
 who think you that there a book bought has  
 ‘Who do you think has bought a book?’  
 a’. Wie<sub>i</sub> heeft <sup>?</sup>(er) t<sub>i</sub> een boek gekocht?  
 who has there a book bought  
 ‘Who has bought a book?’  
 b. Welke jongen<sub>i</sub> denk je [dat <sup>??</sup>(<sup>?</sup>er) t<sub>i</sub> een boek gekocht heeft]?  
 which boy think you that there a book bought has  
 ‘Which boy do you think has bought a book?’  
 b’. Welke jongen<sub>i</sub> heeft (<sup>?</sup>er) t<sub>i</sub> een boek gekocht?  
 which boy has there a book bought  
 ‘Which boy has bought a book?’

It is important to note that the complementizer-trace filter crucially involves a *phonetically realized complementizer*. This is clear from the examples in (192), which show that local *wh*-movement into the clause-initial position of the embedded clause does not require the presence of the expletive *er*, that is, that the empty complementizer  $\emptyset$  does not trigger the complementizer-trace effect. The primed examples in (191) have already shown that the complementizer-trace filter crucially involves a *phonetically realized complementizer*, not just a phonetically filled C-position, as finite verbs in second position do not evoke this effect.

- (192) a. Ik vraag me af [wie<sub>i</sub> Ø <sup>?</sup>(er) t<sub>i</sub> gelogen heeft]?  
 I wonder REFL prt. who COMP there lied has  
 'I wonder who has lied.'
- b. Ik vraag me af [welke jongen<sub>i</sub> Ø (<sup>?</sup>er) t<sub>i</sub> gelogen heeft]?  
 I wonder REFL prt. which boy COMP there lied has  
 'I wonder which boy has lied.'

We conclude this discussion of complementizer-trace effects by raising a warning flag related to the fact that Maling & Zaenen (1978) have suggested that there are regional varieties of Dutch in which the expletive *er* can be freely omitted. Although this claim is controversial, there may indeed be a certain amount of individual variation in speaker judgments when it comes to dropping the expletive in the examples discussed in this subsection. For a more detailed discussion, we refer the reader to Bennis (1986:section 3.6.1).

### III. Restrictions on the syntactic function of the embedded clause

The acceptability of long *wh*-movement depends on properties of the embedded clause from which the *wh*-phrase is extracted. The examples in (193) show that the embedded verb must be an argument of its matrix clause; long *wh*-movement from complementive or adverbial clauses is prohibited.

- (193) a. De directeur had verwacht [dat hij een bonus zou krijgen]. [direct object]  
 the manager had expected that he a bonus would receive  
 'The manager had expected that he would receive a bonus.'
- a'. Wat<sub>i</sub> had de directeur verwacht [dat hij zou t<sub>i</sub> krijgen]?  
 what had the manager expected that he would receive  
 'What had the manager expected that he would receive?'
- b. Het probleem is [dat de directeur een te grote bonus krijgt]. [complementive]  
 the problem is that the manager a too big bonus receives  
 'The problem is that the manager receives a big bonus.'
- b'. \*Wat<sub>i</sub> is het probleem [dat de directeur t<sub>i</sub> krijgt]?  
 what is the problem that the manager receives
- c. De directeur juichte [toen hij een vette bonus kreeg]. [adverbial]  
 the manager cheered when he a fat bonus received  
 'The manager shouted with joy when he received a fat bonus.'
- c'. \*Wat<sub>i</sub> juichte de directeur [toen hij t<sub>i</sub> kreeg]?  
 what cheered the manager when he received

The examples in (194) show that long *wh*-movement is also blocked from argument clauses if they are introduced by the anticipatory pronoun *het* 'it'. This would follow immediately from the observation above if we assume that the anticipatory pronoun is the "true" argument of the verb while the clause is an adjunct or a right-dislocated (that is, clause-external) element.

- (194) a. De directeur had het verwacht [dat hij een bonus zou krijgen].  
 the manager had it expected that he a bonus would receive  
 'The manager had expected it that he would receive a bonus.'
- b. \*Wat<sub>i</sub> had de directeur het verwacht [dat hij t<sub>i</sub> zou krijgen]?  
 what had the manager it expected that he would receive

Long *wh*-movement is not only possible from object clauses but also from subject clauses, as is clear from the fact that impersonal passivization of (193a') gives rise to a fully acceptable result; this is shown in (195a'). Use of an anticipatory pronoun again blocks long *wh*-movement, as is clear from the fact that the passivized counterpart of example (194b) is unacceptable; this is shown in (195b'). For completeness' sake, the primeless examples show that the corresponding cases without long *wh*-movement are both acceptable.

- (195) a. Er werd verwacht [dat hij een bonus zou krijgen].  
 there was expected that he a bonus would receive  
 'It was expected that he would receive a big bonus.'
- a'. Wat<sub>i</sub> werd er verwacht [dat hij zou t<sub>i</sub> krijgen]?  
 what was there expected that he would receive
- b. Het werd verwacht [dat hij een bonus zou krijgen].  
 it was expected that he a bonus would receive  
 'It was expected that he would receive a big bonus.'
- b'. \*Wat<sub>i</sub> werd het verwacht [dat hij zou t<sub>i</sub> krijgen]?  
 what was it expected that he would receive

It should be noted, however, that at least some speakers perceive an argument-adjunct asymmetry in the case of subject clauses. So, while all speakers accept argument extraction both from object and subject clauses, some speakers consider adjunct extraction from subject clauses to yield a worse result than from object clauses; this is illustrated by, respectively, the (a)- and (b)- examples in (196). It suggests that subject but not object clauses are weak islands for *wh*-movement.

- (196) a. Wat<sub>i</sub> verwacht Peter [dat Marie morgen t<sub>i</sub> zal kopen]?  
 what expects Peter that Marie tomorrow will buy  
 'What does Peter expect that Marie will buy tomorrow?'
- a'. Wat<sub>i</sub> wordt er verwacht [dat Marie morgen t<sub>i</sub> zal kopen]?  
 what is there expected that Marie tomorrow will buy
- b. Wanneer<sub>i</sub> verwacht Peter [dat Marie een nieuwe auto t<sub>i</sub> zal kopen]?  
 when expects Peter that Marie a new car will buy  
 'When does Peter expect that Marie will buy a new car?'
- b'. %Wanneer<sub>i</sub> wordt er verwacht [dat Marie een nieuwe auto t<sub>i</sub> zal kopen]?  
 when is there expected that Marie a new car will buy

The acceptability of the passive example in (195a') raises the expectation that long *wh*-movement is also possible from subject clauses in unaccusative constructions. This seems to be borne out by the fact that the modal verb *blijken* 'to turn out' licenses long *wh*-movement provided the anticipatory pronoun *het* 'it' is not present; cf. Bennis (1986:ch.2). Even speakers who consider *wh*-extraction in example (197b) marked with the expletive *er* will agree that there is a sharp contrast in acceptability with regard to the version with the anticipatory pronoun *het*.

- (197) a. Er/Het is gebleken [dat Jan staatsgeheimen verkocht heeft].  
 there/it is appeared that Jan secrets.of.state sold has  
 'It has turned out that Jan has sold official secrets.'

- b. Wat<sub>i</sub> is er/\*het gebleken [dat Jan t<sub>i</sub> verkocht heeft]?  
 what is there/it appeared that Jan sold has

Long *wh*-movement from subject clauses is nevertheless quite rare due to the fact that subject clauses are normally obligatorily introduced by the anticipatory pronoun *het*. For example, the modal verb *schijnen* ‘to seem’ differs from *blijken* in that it does not allow the impersonal construction with the expletive *er* ‘there’, so that long *wh*-movement is categorically excluded.

- (198) a. Het/\*Er schijnt [dat Jan staatsgeheimen verkocht heeft].  
 it/there seems that Jan secrets.of.state sold has  
 ‘It seems that Jan has sold official secrets.’  
 b. \*Wat<sub>i</sub> schijnt het/er [dat Jan t<sub>i</sub> verkocht heeft]?  
 what seems it/there that Jan sold has

The primeless examples in (199) show that the anticipatory pronoun *het* cannot appear if the subject clause is in sentence-initial position, while the primed examples show that long *wh*-movement is nevertheless impossible. This shows that long *wh*-movement is only possible from subject clauses in clause-final position, although it is not clear whether this should be considered a restriction on *wh*-movement, as subject clauses are never possible in the middle field of the clause: cf. Koster (1978).

- (199) a. [Dat Jan staatsgeheimen verkocht had] bleek al snel.  
 that Jan secrets.of.state sold had turned.out PRT quickly  
 ‘It turned out quickly that Jan had sold official secrets.’  
 a’. \*Wat<sub>i</sub> bleek [dat Jan t<sub>i</sub> verkocht had] al snel?  
 what appeared that Jan sold had PRT quickly  
 b. [Dat Jan staatsgeheimen verkocht had] was duidelijk.  
 that Jan secrets.of.state sold had was clear  
 ‘It was clear that Jan had sold official secrets.’  
 b’. \*Wat<sub>i</sub> was [dat Jan t<sub>i</sub> verkocht had] duidelijk?  
 what was that Jan sold had clear

We conclude with a brief digression on matrix verbs that normally select a prepositional object such as *klagen (over)* ‘to complain about’. Although Section 2.3.1, sub VI, has shown that many of these verbs allow the anticipatory pronominal PP to be omitted if the prepositional object is clausal, long *wh*-movement is normally excluded.

- (200) a. Jan klaagt (erover) [dat Marie zijn aantekeningen weg gegooid heeft].  
 Jan complains about.it that Marie his notes away thrown has  
 ‘Jan complains (about it) that Marie has thrown away his notes.’  
 b. \*Wat<sub>i</sub> klaagt Jan (erover) [dat Marie t<sub>i</sub> weg gegooid heeft]?  
 what complains Jan about.it that Marie away thrown has

The verb *hopen (op)* ‘to hope for’ appears to be an exceptional case. Example (201a) first shows that this verb selects a prepositional object; the use of a nominal object (without *op*) leads to an unacceptable result. Example (201b) shows that the

anticipatory pronominal PP *erop* can easily be dropped if the object is clausal; it is in fact the preferred option. Example (201c) finally shows that long *wh*-movement is acceptable if the pronominal PP is not present.

- (201) a. De directeur hoopt \*(op) een grote bonus.  
 the manager hopes for a big bonus  
 ‘The manager is hoping for a big bonus.’  
 b. De directeur hoopt (’erop) [dat hij een grote bonus krijgt].  
 the manager hopes for.it that he a big bonus receives  
 ‘The manager hopes that he will receive a big bonus.’  
 c. Wat<sub>i</sub> hoopt de directeur (\*erop) [dat hij t<sub>i</sub> krijgt]?  
 what hopes the director for.it that he receives  
 ‘What does the manager hope that he will receive?’

The examples in (201) therefore suggest that verbs selecting a prepositional object may license long *wh*-extraction after all. But things are not so simple, given that pronominalization of the embedded clause in (201c) may result in *het*: *De directeur hoopt het* ‘The manager hopes [for] it’. In fact *het* can also be used as an anticipatory pronoun with *hopen*: *De directeur hoopt het [dat hij een grote bonus krijgt]* ‘The manager hopes [it] that he will get a big bonus’. This shows that *hopen* can actually be a transitive verb if it selects a clausal complement. From this we conclude that the acceptability of (201c) does not count as a counterexample to the claim that *wh*-extraction is not possible from prepositional object clauses.

#### IV. Bridge verbs

Subsection III has shown that long *wh*-movement is only possible if the embedded clause has the syntactic function of subject or direct object. This does not mean, however, that long *wh*-movement is possible from any subject or direct object clause, as this may also depend on properties of the matrix predicate: while certain matrix verbs may function as so-called °bridge verbs, others cannot. An important factor involved is factivity: a bridge verb is non-factive in the sense that its use does not imply that the speaker presupposes the truth of the proposition expressed by the complement clause. This accounts for the acceptability contrast between the two (b)-examples in (202); while the use of *weten* ‘to know’ in (202a) implies that the speaker presupposes the proposition “Peter bought an Ipad” to be true, the use of *denken* ‘to think’ does not.

- (202) a. Marie denkt/weet [dat Peter een nieuwe Ipad gekocht heeft].  
 Marie thinks/knows that Peter a new Ipad bought has  
 ‘Marie thinks/knows that Peter has bought a new Ipad.’  
 b. Wat<sub>i</sub> denkt Marie [dat Peter t<sub>i</sub> gekocht heeft]? [non-factive]  
 what thinks Marie that Peter bought has  
 ‘What does Marie think that Peter has bought?’  
 b’. \*Wat<sub>i</sub> weet Marie [dat Peter t<sub>i</sub> gekocht heeft]? [factive]  
 what knows Marie that Peter bought has

There are various other factors that determine whether a specific verb licenses long *wh*-movement. For example, although verbs of saying are typically non-factive,

they do not allow long *wh*-movement when they also express a manner component: while the “neutral” verb *zeggen* ‘to say’ readily allows long *wh*-movement, the verb *fluisteren* ‘to whisper’, the meaning of which includes the additional manner component “*without vibration of the vocal cords*”, does not.

- (203) a. Marie zegt/fluistert [dat Peter een nieuwe Ipad gekocht heeft].  
 Marie says/whispers that Peter a new Ipad bought has  
 ‘Marie says/whispers that Peter has bought a new Ipad.’  
 b. Wat<sub>i</sub> zegt Marie [dat Peter t<sub>i</sub> gekocht heeft]?  
 what says Marie that Peter bought has  
 ‘What does Marie say that Peter has bought?’  
 c. \*Wat<sub>i</sub> fluistert Marie [dat Peter t<sub>i</sub> gekocht heeft]?  
 what whispers Marie that Peter bought has

The discussion above suffices to illustrate that it is not sufficient for long *wh*-movement that the embedded clause is an argument of the verb but that the matrix verb must also satisfy certain criteria in order to be able to function as a bridge verb. For more discussion, we refer the reader to Section 5.1.6, where the distinction between bridge and non-bridge predicates is discussed in greater detail. More restrictions on long *wh*-movement will be discussed in Section 11.3.1.3, where we will focus on so-called islands for *wh*-movement.

*V. Long wh-movement is obligatory and leaves an intermediate trace*

Long *wh*-movement is obligatory in Standard Dutch in order to make a question in which a constituent of an embedded clause takes scope over a matrix clause; if long *wh*-movement is excluded for some reason, such a question can simply not be formed. Since adverbial clauses do not allow long *wh*-movement (cf. Subsection III), it is impossible to question the object *een vette bonus* ‘a big bonus’ in (204a), as is clear from the fact that the two (b)-examples in (204) are both unacceptable as regular *wh*-questions. The number sign indicates that with the right intonation pattern the utterance in (204b) can be interpreted as an °echo-question or with an existential interpretation of *wat* ‘something’, but we can ignore this here.

- (204) a. De directeur juichte [toen hij een vette bonus kreeg].  
 the manager cheered when he a fat bonus received  
 ‘The manager shouted with joy when he received a big bonus.’  
 b. #De directeur juichte [toen hij wat kreeg]?  
 the manager cheered when he what received  
 b’. \*Wat<sub>i</sub> juichte de directeur [toen hij t<sub>i</sub> kreeg]?  
 what cheered the manager when he received

That long *wh*-movement is obligatory to derive questions in which a constituent of an embedded clause has matrix scope is also clear from examples like (205), in which the object clause, as opposed to the adjunct clause in (204), does allow long *wh*-movement: the contrast between the two (b)-examples show that leaving the *wh*-phrase *in situ* blocks the question interpretation. Observe that we added the intermediate trace *t’<sub>i</sub>* to the representation in (205b’) because its presence will become relevant in the discussion below.

- (205) a. Marie denkt [dat ik een olifant gezien heb].  
 Marie thinks that I an elephant seen have  
 ‘Marie thinks that I have seen an elephant.’  
 b. #Marie denkt [dat ik wat gezien heb]?  
 Marie thinks that I what seen have  
 b’. Wat<sub>i</sub> denkt Marie [*t*<sub>i</sub> dat ik *t*<sub>i</sub> gezien heb]?  
 what thinks Marie that I seen have  
 ‘What does Marie think that I have seen?’

The obligatoriness of long *wh*-movement is expected on the hypothesis (discussed in Section 11.3.1.1, sub II) that *wh*-movement is needed to create an operator-variable chain. However, it leaves unexplained that Standard Dutch differs markedly from some of its dialects (as well as German) in that it does not allow so-called partial *wh*-movement and/or *wh*-doubling. Partial *wh*-movement is illustrated in (206a) by means of an example taken from Barbiers, Koeneman & Lekakou (2010); it is characterized by the fact that the actual scope position of the *wh*-phrase (here: *wie*) is marked by some place holder (here: the *wh*-element *wat*); the *wh*-phrase cannot remain in its clause-internal base position, but must at least move into the clause-initial position of its own clause.

- (206) a. Wat denk je [wie ik gezien heb]? [Dialect from Overijssel]  
 what think you who I seen have  
 ‘Who do you think that I have seen?’  
 b. \*Wat denk je [wie ik gezien heb]? [Standard Dutch]  
 what think you who I seen have

*Wh*-doubling is illustrated in example (207a), and is characterized by the fact that the *wh*-phrase does not only occupy its scope position but also the clause-initial position of the embedded clause; see Boef (2013) for a discussion of a similar phenomenon in relative clauses.

- (207) a. Wie denk je [wie ik gezien heb]? [Dialect from Drenthe]  
 who think you who I seen have  
 ‘Who do you think that I have seen?’  
 b. \*Wie denk je [wie ik gezien heb]? [Standard Dutch]  
 who think you who I seen have

Barbiers, Koeneman & Lekakou argue that the two examples in (206) and (207) can be seen as the result of cyclic movement if we adopt Chomsky’s (1995:ch.3) copy theory of movement, according to which movement is a two-step operation: the content of the “moved” phrase is first copied and subsequently inserted in some higher position. The difference between long *wh*-movement and *wh*-doubling is simply that in the former case only the highest copy is phonetically spelled-out, whereas in the latter case all copies in clause-initial position are spelled-out; this is indicated in (208), in which strikethrough indicates that the copy is not spelled out.

- (208) a. Wie<sub>i</sub> denk je [wie<sub>i</sub> C [ik ~~wie~~<sub>i</sub> gezien heb]]? [*wh*-doubling]  
 b. Wie<sub>i</sub> denk je [~~wie~~<sub>i</sub> C [ik ~~wie~~<sub>i</sub> gezien heb]]? [long *wh*-movement]



Partial *wh*-movement is analyzed in essentially the same way as *wh*-doubling, with this difference that *wat* ‘what’ is considered a *partial* copy of *wie* ‘who’; these pronouns are the spell-out of virtually the same set of features with the exception of [+HUMAN], which is lacking in *wat*; see Barbiers, Koeneman & Lekakou (2010) for details. If the suggested analysis is on the right track, this would provide evidence in favor of the cyclic movement approach to long *wh*-movement. It should be noted, however, that the proposal is controversial; we refer to Schippers (2012:ch.4) and Pankau (2014) for extensive reviews of various proposals and further discussion.

VI. Long *wh*-movement from infinitival clauses

Section 5.2 has shown that there three formally different types of infinitival clauses: *om* + *te*-infinitivals, *te*-infinitivals and bare infinitivals. A few typical examples are given in (209).

- (209) a. Jan beloofde [om PRO het boek naar Els te sturen]. [*om* + *te*-infinitival]  
 Jan promised COMP the book to Els to send  
 ‘Jan promised to send the book to Els.’
- b. Jan beweerde [<sub>TP</sub> PRO het boek naar Els te sturen]. [*te*-infinitival]  
 Jan claimed the book to Els to send  
 ‘Jan claimed to send the book to Els.’
- c. Jan wilde [PRO het boek naar Els sturen]. [bare infinitival]  
 Jan wanted the book to Els send  
 ‘Jan wanted to send the book to Els.’

It seems that long *wh*-movement from *om* + *te*-infinitival clauses gives rise to a more degraded result than long *wh*-movement from *te*-infinitival clauses. This can be easily demonstrated by means of the verb *proberen* ‘to try’, as this verb is possible with both clause types; although some speakers object to the two primed examples in (210), our informants consider (210a’) much worse than (210b’). Observe that we give the examples in the perfect tense in order to show that both examples involve extraposed clauses. The labels CP/TP indicate that the two types of infinitival clause differ in size; we refer the reader to Section 5.2.2 for extensive discussion of the claim that *om* + *te*-infinitivals are CPs, while *te*-infinitivals are TP.

- (210) a. Jan heeft geprobeerd [<sub>CP</sub> om PRO het boek naar Els te sturen]. [*om* + *te*-inf.]  
 Jan has tried COMP the book to Els to send  
 ‘Jan has tried to send the book to Els.’
- a’. <sup>\*?</sup>Wat<sub>i</sub> heeft Jan geprobeerd [<sub>CP</sub> om PRO *t*<sub>i</sub> naar Els te sturen]?  
 what has Jan tried COMP to Els to send  
 ‘What has Jan tried to send to Els?’
- b. Jan heeft geprobeerd [<sub>TP</sub> PRO het boek naar Els te sturen]. [*te*-infinitival]  
 Jan has tried the book to Els to send  
 ‘Jan has tried to send the book to Els.’
- b’. <sup>%</sup>Wat<sub>i</sub> heeft Jan geprobeerd [<sub>TP</sub> PRO *t*<sub>i</sub> naar Els te sturen]?  
 what has Jan tried to Els to send  
 ‘What has Jan tried to send to Els?’

The degraded status of examples such as (210a') suggests that *om* + *te*-infinitivals differ from finite declarative clauses in that they do not accommodate cyclic *wh*-movement, which may in fact be in line with the finding in Section 11.3.1.1, sub IV, that embedded infinitival *wh*-questions are not common in colloquial speech. If true, this entails that long *wh*-movement from *te*-infinitivals in examples like (210b') differs from long *wh*-movement from finite declaratives in that it must apply in one fell swoop; this is of course also suggested by the fact that TPs do not contain the position normally associated with *wh*-movement, the specifier of CP. That *wh*-movement in one fell swoop is possible in (210b') is not surprising in light of the fact discussed in Section 5.2.2.3 that extraposed *te*-infinitivals are semi-transparent in the sense that they allow the infinitival clause to be split, as illustrated in (211). If this split is the result of leftward scrambling of the object *het boek*, there is no obvious reason for assuming that leftward *wh*-movement of the interrogative pronoun *wat* 'what' would be impossible in (210b').

- (211) %Jan heeft *het boek* geprobeerd *naar Els te sturen*.  
 Jan has the book tried to Els to send  
 'Jan has promised to send the book to Els.'

Section 5.2.2.3 has further shown that there are two types of *te*-infinitivals. The semi-transparent type, which was already illustrated in the (b)-examples in (210), is characterized by the fact that the matrix verb appears as a participle in the perfect tense and that splitting the infinitival clause is considered marked by at least some speakers. The transparent type is characterized by the fact that the matrix verb appears as an infinitive in the perfect tense and that splitting of the infinitival clause is obligatory in the northern variety of standard Dutch as a result of verb clustering. This type can again be illustrated by means of the matrix verb *proberen* 'to try', as this verb may also take transparent *te*-infinitivals as its object. Examples like (212a) exhibit monoclausal behavior and it is therefore not surprising that *wh*-movement of the object of the infinitival verb *sturen* 'to send' is fully acceptable for all speakers.

- (212) a. Jan heeft *het boek naar Els proberen<sub>infinitive</sub> te sturen*.  
 Jan has the book to Els try to send  
 'Jan has promised to send the book to Els.'  
 b. *Wat<sub>i</sub> heeft Jan t<sub>i</sub> naar Els proberen te sturen?*  
 what has Jan to Els try to send  
 'What has Jan tried to send to Els?'

Bare infinitival complements always exhibit monoclausal behavior; the examples in (213) show that, as expected, bare infinitivals freely allow *wh*-movement of the complement of the infinitival verb.

- (213) a. Jan heeft *het boek naar Els willen sturen*.  
 Jan has the book to Els want to send  
 'Jan has tried to send the book to Els.'  
 b. *Wat<sub>i</sub> heeft Jan t<sub>i</sub> naar Els willen sturen?*  
 what has Jan to Els want send  
 'What has Jan wanted to send to Els?'

The discussion above suggests that cyclic *wh*-movement does not apply in the case of an infinitival complement clause, and that *wh*-extraction from such clauses must therefore apply in one fell swoop. It should be noted, however, that the literature has not paid much attention to *wh*-extraction from *om* + *te*- and *te*-infinitivals so far and that it might be useful to investigate our claim here in more depth, as judgments are not always very clear (perhaps caused by the interference of constructions with infinitival goal clauses, which are likewise introduced by *om*: cf. *Wat doet u om af te vallen?* ‘What do you do to lose weight?’).

### 11.3.1.3. *Islands for question formation*

Section 11.3.1.1 has shown that *wh*-movement is a near-obligatory operation in the formation of *wh*-questions, as it is needed to create operator-variable chains. From a semantic point of view the formation of such chains requires preposing of the *wh*-element only, but if some syntactic restriction blocks extraction of this element, *wh*-movement may also pied-pipe a larger phrase. If such a restriction does not apply, stranding normally is the preferred option. Section 11.3.1.2 has further shown that embedded clauses cannot be pied-piped by *wh*-movement; consequently, if long *wh*-movement is impossible for some reason, certain semantically plausible questions simply cannot be formed.

The seminal work of Ross (1967) has made it clear that there is a wide range of constructions that resist the formation of semantically plausible *wh*-questions. We will refer to such cases as ISLANDS for question formation, thus taking the notion of island in a slightly stricter sense than is normally done by not only excluding *wh*-extraction (stranding) but also pied piping; the reason is purely practical given that stranding and pied piping were already discussed in Section 11.3.1.1. As this section will focus on the empirical data from Standard Dutch, we refer the reader to Szabolsci (2006), Müller (2011) and Boeckx (2012) for recent theoretical approaches to island phenomena.

#### 1. *Factive islands: the distinction between strong and weak islands*

Section 11.3.1.2, sub IV, has shown that long *wh*-movement is normally excluded from factive clauses. This is illustrated again in example (214b): while long *wh*-movement is fully acceptable with the non-factive matrix verb *denken* ‘to think’, it gives rise to a degraded result with the factive matrix verb *weten* ‘to know’. It must be noted, however, that some speakers do allow long *wh*-movement if the *wh*-phrase is °D-linked such as *welk boek* ‘which book’ in (214b’). Recall that we do not include the intermediate trace in the initial position of the embedded clause if this is not immediately relevant for our discussion.

- (214)
- Long *wh*-movement from factive islands
    - a. Jan dacht/wist [dat Marie zijn boek gekocht had].  
Jan thought/knew that Marie his book bought had  
‘Jan thought/knew that Marie had bought his book.’
    - b. Wat<sub>i</sub> dacht/\*wist Jan [dat Marie t<sub>i</sub> gekocht had]?  
what thought/knew Jan that Marie bought had
    - b’. Welk boek<sub>i</sub> dacht/<sup>°</sup>wist Jan [dat Marie t<sub>i</sub> gekocht had]?  
which book thought/knew Jan that Marie bought had

The percentage sign in (214b') indicates that judgments differ from speaker to speaker and from case to case; the (b)-examples in (214) improve for many speakers if we substitute the factive verb *betreuren* 'to regret' for *weten* 'to know', as in (215).

- (215) a. <sup>?</sup>Wat<sub>i</sub> betreurde Jan [dat Marie t<sub>i</sub> gekocht had]?  
 what regretted Jan that Marie bought had  
 b. <sup>?</sup>Welk boek<sub>i</sub> betreurde Jan [dat Marie t<sub>i</sub> gekocht had]?  
 which book regretted Jan that Marie bought had

That there is a great deal of speaker variation is clear from the fact that the judgments on examples such as (215a) found in the linguistic literature also vary considerably: some researchers reject examples of this type as fully ungrammatical (e.g. Hoeksema 2006:147), while others accept them as fully acceptable (e.g. Bennis 1986:104) or suggest some intermediate status (Barbiers 1998). The diacritics here should not be considered as the expression of absolute but of relative judgments: the use of a double question mark in (215a) instead of an asterisk at least does justice to the fact that this example deteriorates enormously when the anticipatory pronoun *het* 'it' is added (cf. \*Wat<sub>i</sub> betreurde Jan het [dat Marie t<sub>i</sub> gekocht had]?) and that it is less felicitous than examples such as (215b), which involve extraction of a D-linked *wh*-phrase. Examples such as (215b) are sometimes given as fully acceptable in the literature (e.g. Zwart 2011:209) but since at least some speakers feel uncomfortable with them, we have added a question mark.

The crucial thing for our present discussion is that the acceptability contrast between long *wh*-movement of non-D-linked and D-linked *wh*-phrases from factive complements is beyond doubt. This contrast shows that certain islands are not STRONG (absolute), but WEAK (selective) in that they block *wh*-extraction of certain elements but not others. It is often claimed that weak-island violations are sensitive to the referential properties of the *wh*-phrase in the sense that extraction is only possible if the descriptive part of the *wh*-phrase denotes a certain pre-established set of entities in the domain of discourse; see Szabolsci (2006; section 5) and the references cited there. D-linked *wh*-phrases such as *welk boek* 'which book' satisfy this criterion, while non-D-linked pronouns *wie* 'who' and *wat* 'what' normally do not and at best presuppose the existence of some entity that satisfies the description of the predicative part of the question. Example (216b) shows that weak islands normally also block long *wh*-movement of non-arguments like adverbial adjuncts (but see Szabolsci 2006 for some exceptional cases).

- (216) a. Jan dacht/wist [dat Marie zijn boek bij Amazon gekocht had].  
 Jan thought/knew that Marie his book at Amazon bought had  
 'Jan thought/knew that Marie had bought his book at Amazon.'  
 b. Waar<sub>i</sub> dacht/\*wist Jan [dat Marie zijn boek t<sub>i</sub> gekocht had]?  
 where thought/knew Jan that Marie his book bought had

## II. Embedded questions

*Wh*-extraction is not possible from embedded interrogative clauses: this holds for polar *yes/no*-questions as well as for *wh*-questions. That *yes/no*-questions are islands for question formation is illustrated in (217b); the fact that the *wh*-phrase *welk boek* 'which book' is D-linked shows that such islands are strong.

- (217) a. Jan vroeg [of Marie het boek gekocht had].  
 Jan asked if Marie the book bought had  
 ‘Jan asked whether Marie had bought the book.’  
 b. \*Welk boek<sub>i</sub> vroeg Jan [of Marie t<sub>i</sub> gekocht had]?  
 which book asked Jan whether Marie bought had

Although examples such as (217b) are not often explicitly discussed, its degraded status can readily be accounted for by assuming that the clause-initial position of the embedded clause is not accessible for the *wh*-phrase due to the presence of a phonetically empty polar question operator. This assumption may be needed anyway in order to exclude *wh*-movement in polar main clauses like (218a); *wh*-movement is possible only if the position preceding the finite verb is radically empty, which accounts for the fact that (218b) is a pure *wh*-question that does not leave room for a polar interpretation. For completeness’ sake, we added example (218c) to show that the *wh*-element cannot remain *in situ* either.

- (218) a. OP<sub>[+Q]</sub> Koopt Peter het boek?  
 buys Peter the book  
 ‘Does Peter buy the book?’  
 b. Welk boek<sub>i</sub> koopt Peter t<sub>i</sub>?  
 which book buys Peter  
 ‘Which book does Peter buy?’  
 c. \*OP<sub>[+Q]</sub> Koopt Peter welk boek?  
 buys Peter which book

If the clause-initial position of embedded polar questions is indeed occupied by a phonetically empty question operator, the unacceptability of long *wh*-movement of (217b) follows from the standard analysis in generative grammar that *wh*-extraction cannot apply in a single movement step, but must proceed via the clause-initial position of the object clause. This analysis can be straightforwardly extended to account for the unacceptability of cases like (219), in which long *wh*-movement takes place from embedded *wh*-questions. Observe that (219c) is fully acceptable if the adverbial phrase modifies the °matrix clause, but this is of course not the reading intended here (as is indicated by the °trace t<sub>j</sub>).

- (219) a. \*Wat<sub>j</sub> vroeg je [wie<sub>i</sub> t<sub>i</sub> t<sub>j</sub> gekocht heeft]? [non-D-linked]  
 what asked you who bought has  
 ‘What did you ask who has bought?’  
 b. \*Welk boek<sub>j</sub> vroeg je [wie<sub>i</sub> t<sub>i</sub> t<sub>j</sub> gekocht heeft]? [D-linked]  
 which book asked you who bought has  
 ‘Which book did you ask who has bought?’  
 c. \*Wanneer<sub>j</sub> vroeg je [wie<sub>i</sub> t<sub>i</sub> t<sub>j</sub> vertrokken was]? [adverbial adjunct]  
 when asked you who left had  
 ‘When did you ask who had left?’

*Wh*-islands have been reported to be weak in many languages, including English. This does not seem to be the case in Dutch, as most speakers seem to consider all examples in (219) to be (equally) bad; see, e.g., Koster (1987:192ff.) and Zwart (2011:208). However, Koster (1987:22) claimed that long movement is more

acceptable if the *wh*-phrase in the clause-initial position of the embedded clause is not a subject, as in the examples in (220), to which Koster assigns a mere question mark. It should further be noted that Koopman & Sportiche (1985) have claimed that long *wh*-movement of PPs in examples such as (220a') is more acceptable than long *wh*-movement of objects in examples such as (220b'), although Koster (1987) does not seem to agree with this. To our knowledge, *wh*-island violations of this sort have not been discussed elsewhere and since their precise status is not clear to us, we simply mark them with a percentage sign.

- (220) a. Jan wil weten [welk boek<sub>i</sub> jij t<sub>i</sub> aan Marie gegeven hebt].  
 Jan wants know which book you to Marie given have  
 'Jan wants to know which book you have given to Marie.'
- a'. %Aan wie<sub>j</sub> wil Jan weten [welk boek<sub>i</sub> jij t<sub>i</sub> t<sub>j</sub> gegeven hebt]?  
 to whom wants Jan know which book you given have
- b. Jan wil weten [aan wie<sub>j</sub> jij dit boek t<sub>j</sub> gegeven hebt].  
 Jan wants know to whom you this book given have  
 'Jan wants to know to whom you have given this book.'
- b'. %Welk boek<sub>j</sub> wil Jan weten [aan wie<sub>j</sub> jij t<sub>i</sub> t<sub>j</sub> gegeven hebt]?  
 to whom wants Jan know to whom you given have

### III. Subject clauses

Long *wh*-movement typically involves extraction from direct object clauses. It is sometimes claimed that long *wh*-movement from subject clauses is excluded; cf. Huang (1982). Examples supplied to illustrate this normally involve subject clauses in non-extrapolated position or subject clauses introduced by the anticipatory pronoun *het* 'it'; see, e.g., Zwart (2011:202ff.). Section 11.3.1.2, sub III, has already shown, however, that there are subject clauses in extrapolated position that allow long *wh*-movement if the anticipatory pronoun *het* is not present. We illustrate this again in (221b) by means of the passive counterpart of the construction in (221a) with an object clause. The fact that the extracted phrase is the non-D-linked pronoun *wat* 'what' in fact shows that subject clauses are not even weak islands.

- (221) a. Wat<sub>i</sub> had de directeur verwacht [dat hij zou t<sub>i</sub> krijgen]? [direct object]  
 what had the manager expected that he would receive  
 'What had the manager expected that he would receive?'
- b. Wat<sub>i</sub> werd er verwacht [dat hij zou t<sub>i</sub> krijgen]? [subject]  
 what was there expected that he would receive

The fact that long *wh*-movement from subject clauses is nevertheless rare is due to the fact that such clauses are normally preceded by the anticipatory pronoun *het* if they occur in extrapolated position; see Section 11.3.1.2, sub III, for more details.

### IV. Adjunct clauses

Adverbial clauses differ from argument clauses in that they always constitute islands for *wh*-formation; cf. Huang (1982). This is illustrated in (222) for adverbial clauses indicating time and reason. The fact that the primed examples involve the D-linked phrase *Welke foto's* 'which pictures' shows that adjunct clauses are strong islands for *wh*-movement.

- (222) a. Marie vertrok [toen Jan zijn vakantiefoto's wou laten zien].  
 Marie left when Jan his vacation.pictures wanted let see  
 'Marie left when Jan wanted to show his vacation pictures.'
- a'. \*Welke foto's vertrok Marie [toen Jan  $t_i$  wou laten zien]?  
 which pictures left Marie when Jan wanted let see
- b. Marie vertrok [omdat Jan zijn vakantiefotos wou laten zien].  
 Marie left because Jan his vacation.pictures wanted let see  
 'Marie left because Jan wanted to show his vacation pictures.'
- b'. \*Welke foto's vertrok Marie [omdat Jan  $t_i$  wou laten zien]?  
 which pictures left Marie because Jan wanted let see

### V. Complex noun phrases

Section 11.3.1.1, sub VB has shown that, contrary to what is commonly assumed, there are reasons for assuming that noun phrases are islands for postnominal *wh*-phrases. This was argued on the basis of examples such as (223), which show that both the stranding and the pied piping option are excluded.

- (223) a. Els zal morgen [haar klacht [tegen Peter]] intrekken.  
 Els will tomorrow her complaint against Peter withdraw  
 'Els will withdraw her complaint against Peter tomorrow.'
- b. \*[Tegen wie]<sub>i</sub> zal Els [haar klacht  $t_i$ ] morgen intrekken?  
 against who will Els her complaint tomorrow withdraw
- c. \*[Haar klacht [tegen wie]]<sub>i</sub> zal Els morgen  $t_i$  intrekken?  
 her complaint against who will Els tomorrow withdraw

The islandhood of noun phrases for *wh*-phrases embedded in postnominal clauses is uncontroversial. This holds regardless of the syntactic status of the postnominal clause: the (a)-examples show this for a clausal complement and the (b)-examples for a relative clause. The fact that the primed examples involve D-linked noun phrases shows that complex noun phrases are strong islands for *wh*-movement. For completeness' sake, it should be mentioned that extraposition of the relative clause does not improve the result.

- (224) a. De directeur heeft [het gerucht [dat Jan deze baan krijgt]] bevestigd.  
 the manager has the rumor that Jan this job gets confirmed  
 'The manager has confirmed the rumor that Jan will get the job.'
- a'. \*Welke baan<sub>i</sub> heeft de directeur [het gerucht [dat Jan  $t_i$  krijgt]] bevestigd?  
 which job has the manager the rumor that Jan gets confirmed
- b. Marie heeft [de man [die haar boek gerecenseerd had]] ontmoet.  
 Marie has the man who her book reviewed had met  
 'Marie has met the man who had reviewed her book.'
- b'. \*Welk boek<sub>i</sub> heeft Marie [de man [die  $t_i$  gerecenseerd had]] ontmoet?  
 which book has Marie the man who reviewed had met

### VI. Coordinate structures

Islands for question formation are normally clausal in nature due to the fact that non-sentential clausal constituents regularly allow either stranding or pied piping; see Section 11.3.1.1, sub V and VI. Coordinate structures are, however, notable



exceptions to this. The examples in (225) first show that the full coordinate structure can be easily questioned.

- (225) a. Jan heeft [[een boek] en [een CD]] gekocht.  
 Jan has a book and a CD bought  
 ‘Jan has bought a book and a CD.’  
 b. Wat<sub>i</sub> heeft Jan t<sub>i</sub> gekocht? [[Een boek] en [een CD]].  
 what has Jan bought a book and a CD  
 ‘What has Jan bought? A book and a CD.’

It is, however, impossible to question one of the conjuncts: the (a)-examples in (226) show that *wh*-movement of one of the conjuncts while stranding the remainder of the coordinate structure is excluded; the (b)-examples show that pied piping of the complete coordinate structure is excluded as well.

- (226) a. \*Wat<sub>i</sub> heeft Jan [[een boek] en [ t<sub>i</sub> ]] gekocht?  
 what has Jan a book and bought  
 a'. \*Wat<sub>i</sub> heeft Jan [[ t<sub>i</sub> ] en [een CD]] gekocht?  
 what has Jan and a CD bought  
 b. \*[[Een boek] en [wat]]<sub>i</sub> heeft Jan t<sub>i</sub> gekocht?  
 a book and what has Jan bought  
 b'. \*[[Wat] en [een CD]]<sub>i</sub> heeft Jan t<sub>i</sub> gekocht?  
 what and a CD has Jan bought

Although it is not entirely clear what the correct representation of “split” coordinate structures like (227a) is, it might be interesting to note that such cases do not allow question formation either.

- (227) a. Jan heeft een boek gekocht, en (ook) een CD.  
 Jan has a book bought and also a CD  
 ‘Jan has bought a book as well as a CD.’  
 b. \*Wat heeft Jan t<sub>i</sub> gekocht, en (ook) een CD.  
 what has Jan bought and also a CD

The examples above have shown that *wh*-extraction from coordinated structures is not possible. A potential exception is the so-called across-the-board movement, which may extract *wh*-phrases from coordinated structures provided that all the conjuncts are affected in a parallel way. Note that the strikethrough in (228b) is the result of backward °conjunction reduction, which need not bother us here.

- (228) a. Welk boek<sub>i</sub> zal [[Jan t<sub>i</sub> bewonderen] maar [Marie t<sub>i</sub> verafschuwen]].  
 which book will Jan admire but Marie loathe  
 ‘Which book will Jan admire and Marie loathe?’  
 b. Aan wie<sub>i</sub> zal [[Jan een boek t<sub>i</sub> ~~geven~~] en [Peter een CD t<sub>i</sub> geven]]?  
 to whom will Jan a book give and Peter a CD give  
 ‘To whom will Jan give a book and Peter give a CD.’

Observe that across-the-board movement always involves subextraction from a conjunct, that is, it must leave a remnant. This is shown by the unacceptability of examples like (229a). It is not clear, however, whether this is due to a syntactic

constraint, as example (229b) shows that *wh*-movement of the full coordinate structure is also impossible. The use of the dollar sign indicates that we may be dealing with a simple economy effect because the answer to *Wat heeft Jan gekocht?* may involve a list: *Een boek, een plaat, ...* ‘A book, a record, ...’.

- (229) a. \**Wat<sub>i</sub> heeft Jan [[t<sub>i</sub>] en [ t<sub>i</sub>]] gekocht?*  
           what has Jan and bought  
       b. *§[Wat en wat] heeft Jan t<sub>i</sub> gekocht?*  
           what and what has Jan bought

Given that the *wh*-phrase in across-the-board movement constructions is associated with two independent gaps, it is controversial whether the examples in (228) are derived by *wh*-movement in a run-of-the-mill fashion. We will not digress on this theoretical issue here but refer the reader to De Vries (2014) for extensive discussion.

### VII. A note on resumptive prolepsis

Standard German differs from Standard Dutch in that many speakers of German do not allow long *wh*-movement constructions such as (230a). Such speakers may employ various alternative strategies in order to overcome this problem, one of which is using the resumptive prolepsis construction illustrated in (230b), in which a proleptic phrase (here: *von welchem Maler*) obligatorily binds a resumptive pronoun within the embedded clause; see Salzmann (2006) for extensive discussion.

- (230) a. *°Wen<sub>i</sub> glaubst du [dass Petra t<sub>i</sub> liebt]?* [German]  
           who think you that Petra loves  
           ‘Who do you think that Petra likes?’  
       b. *Von welchem Maler<sub>i</sub> glaubst du [dass Petra ihn<sub>i</sub> liebt].*  
           of which painter think you that Petra him loves  
           ‘Which painter do you think that Petra likes?’

The resumptive prolepsis construction is not unique to speakers that do not allow long *wh*-movement, as is clear from the fact that in Standard Dutch, the two constructions in (231) are possible side by side.

- (231) a. *Wie<sub>i</sub> denk je [dat Marie/zij t<sub>i</sub> bewondert]?* [Dutch]  
           who think you that Marie/she admires  
           ‘Who do you think that Marie/she admires?’  
       b. *Van welke schilder<sub>i</sub> denk je [dat Marie hem<sub>i</sub> bewondert]?*  
           of which painter think you that Marie him admires

The long *wh*-movement and resumptive prolepsis construction exhibit a number of similarities, to which we will return in Section 11.3.6. These may make one think that they are both derived by means of *wh*-movement (in which case something special should be said about the use of the preposition *von/van* and the insertion of the resumptive pronoun). Salzmann (2006) argues, however, that there are various reasons not to adopt this line of thinking. One of the main reasons is that the resumptive prolepsis construction is not sensitive to islands. This is illustrated in (232) for factive islands: while (232a) shows that long *wh*-movement gives rise to a

degraded result for many speakers, (232b) shows that the corresponding resumptive prolepsis construction is fully acceptable.

- (232) a. <sup>%</sup>Welk boek<sub>i</sub> wist Jan niet [dat Els t<sub>i</sub> gekocht had]? [wh-movement]  
 which book knew Jan not that Els bought had  
 b. Van welk boek<sub>i</sub> wist Jan niet [dat Els het<sub>i</sub> gekocht had]? [prolepsis]  
 of which book knew Jan not that Els it bought it  
 ‘Of which book didn’t Jan know that Els had bought?’

Assuming that the resumptive prolepsis construction is derived by *wh*-movement becomes even less plausible when we consider strong islands, like the embedded questions in (233). The contrast between the primeless and primed examples shows that while long *wh*-movement is impossible, the corresponding resumptive prolepsis constructions are again fully acceptable.

- (233) a. \*Welk boek<sub>i</sub> wist Jan niet [of Els t<sub>i</sub> gekocht had]? [wh-movement]  
 which book knew Jan not if Els bought had  
 a’. Van welk boek<sub>i</sub> wist Jan niet [of Els het<sub>i</sub> gekocht had]? [prolepsis]  
 of which book knew Jan not if Els it bought had  
 ‘Of which book didn’t Jan know if Els had bought it?’  
 b. \*Welk boek<sub>i</sub> wist Jan niet [wie t<sub>i</sub> gekocht had]? [wh-movement]  
 which book knew Jan not who bought had  
 b’. Van welk boek<sub>i</sub> wist Jan niet [wie het<sub>i</sub> gekocht had]? [prolepsis]  
 of which book knew Jan not who it bought had  
 ‘Of which book didn’t Jan know who had bought it?’

If *wh*-movement is not involved in the derivation of the resumptive prolepsis construction, the proleptic phrase must find its origin within the matrix clause. Consequently, the (obligatory) coindexing in the examples above must be due to the normal conditions on °binding of referential pronouns, which does not seem to pose any special problems as the pronoun is free in its local domain; cf. Section N5.2.1.5. An appeal to the normal mechanisms involved in binding would also immediately explain the fact illustrated in example (234) that the proleptic phrase may serve as the antecedent of two (or more) resumptive pronouns.

- (234) Van welk boek<sub>i</sub> wist Jan niet [of hij het<sub>i</sub> wilde kopen]  
 of which book knew Jan not if he it wanted buy  
 [voordat hij het<sub>i</sub> gelezen had]?  
 before he it read had  
 ‘Of which book didn’t Jan know if he wanted to buy it before he had read it?’

A *wh*-movement approach, on the other hand, would certainly need various additional provisos to account for this option because *wh*-phrases in clause-initial position are normally associated with only a single °argument position: the interrogative pronoun *who* in (235a), for example, functions as a subject, as is clear from the fact that (235b) is a felicitous answer to (235a), but it cannot simultaneously function as a subject and an object, as is clear from the fact that (235b’) is not a felicitous answer to (235a).

- (235) a. Who will meet?  
 b. John and Mary (will meet). [appropriate answer]  
 b'. John (will meet) Mary. [inappropriate answer]

That the proleptic phrase must be independently licensed within the matrix clause may also account for the fact that resumptive prolepsis is especially common with a limited number of predicates, including *denken* 'to think', *geloven* 'to believe', *hopen* 'to hope', *vermoeden* 'to suspect', *vertellen* 'to tell', *vrezen* 'to fear', (*niet weten* 'to know (not)') *zeggen* 'to say', and *zich afvragen* 'to wonder'. The unacceptability of example (236b) follows immediately if the predicate *vertrekken* 'to leave' is not able to license a proleptic *van*-phrase. The *wh*-movement approach to resumptive prolepsis, on the other hand, would have to explain why adjuncts differ from embedded questions in this respect, which will be difficult in the light of the fact that they both behave as strong islands in other contexts.

- (236) a. \*Welk bericht<sub>i</sub> vertrok Peter [nadat hij <sub>t<sub>i</sub></sub> gelezen had]?  
 which message left Peter after he read had  
 b. \*Van welk bericht<sub>i</sub> vertrok Peter [nadat hij het<sub>i</sub> gelezen had]?  
 of which message left Peter after he it read had

For completeness' sake, we conclude by noting that resumptive prolepsis is also possible in constructions such as (237b'), in which the proleptic phrase is associated with the adverbial proform *er* 'there'.

- (237) a. Jan wist niet dat/of ik in Amsterdam gewoon had.  
 Jan knew not that.if I in Amsterdam lived had  
 'Jan didn't know that/whether I had lived in Amsterdam.'  
 b. In welke stad wist Jan niet <sup>?dat/\*of</sup> ik gewoon <sub>t<sub>i</sub></sub> had.  
 in which town knew Jan not that/if I lived had  
 b'. Van welke stad wist Jan niet <sup>?dat/\*of</sup> ik *er* gewoon had.  
 of which town knew Jan not that/if I there lived had

#### 11.3.1.4. Multiple *wh*-questions

Section 11.3.1.1, sub II, has shown that *wh*-movement is normally obligatory in Standard Dutch, which may be accounted for by the hypothesis that *wh*-movement derives an operator-variable chain in the sense of predicate calculus: an example like (238a) can be translated more or less directly into the informal semantic formula in (238b).

- (238) a. Wat<sub>i</sub> leest Peter <sub>t<sub>i</sub></sub>?  
 what reads Peter  
 'What is Peter reading?'  
 b. ?<sub>x</sub> (Peter reads <sub>x</sub>)

Notable exceptions to the obligatoriness of *wh*-movement are the so-called multiple *wh*-questions of the type in (239); in examples like these only a single *wh*-phrase is moved into clause-initial position while the second (third, etc.) is left *in situ*; all *wh*-phrases must be accented (which is indicated by small caps).

- (239) a. WIE heeft WAT gelezen?  
 who has what read  
 ‘Who has read what?’  
 b. WIE heeft WIE WAT gegeven?  
 who has who what given  
 ‘Who has given what to whom?’

This section discusses questions of the type in (239). Subsection I starts by discussing two characteristics of multiple *wh*-questions: (i) they have a so-called pair-list reading, and (ii) all *wh*-phrases must be accented. Subsection II continues with a discussion of the syntactic function of the *wh*-phrases involved in multiple *wh*-questions. Subsection III discusses the fact that the second (third, etc.) *wh*-phrase in (239) cannot undergo *wh*-movement but remains *in situ*, and relates this to the fact that the *wh*-phrase *in situ* may occur in strong islands. Subsection IV concludes by discussing word order restrictions on multiple *wh*-questions: the *wh*-phrases involved tend to appear in the unmarked order of their non-interrogative counterparts. Before we start, we should raise a warning flag since the examples like (239) can also be interpreted as (multiple) echo-questions; native speakers should therefore avoid reading the examples in the following subsections with an exclamative contour.

### *I. Semantic and phonetic characteristics: the pair-list reading and intonation*

In multiple questions, *wh*-movement applies to just a single *wh*-phrase; the second (third, etc.) is left *in situ*. At first, this may seem surprising given the hypothesis discussed in Section 11.3.1.1, sub II, that *wh*-movement is needed to create operator-variable chains. For this reason it has been argued that examples like (240a) involve covert (invisible) movement of the second *wh*-phrase; see, e.g., May (1985) and Lasnik & Saito (1992). It might also be the case, however, that the second *wh*-phrase may remain *in situ* because it does not take scope independently, as the formula ?x ?y (x has read y) does not properly express the meaning of example (240a). Multiple questions instead have a so-called PAIR-LIST reading, which is given in (240b). A proper answer thus consists of a list of ordered pairs <x,y>: Marie has read *Max Havelaar* by Multatuli, Jan has read *De Kapellekensbaan* by Louis-Paul Boon, Els has read *De zondvloed* by Jeroen Brouwers, etc.

- (240) a. WIE heeft WAT gelezen?  
 who has what read  
 ‘Who has read what?’  
 b. ?<x,y> (x has read y)

We refer the reader to Van Riemsdijk & Williams (1986:ch.13), Dayal (2006) and Bayer (2006) for reviews of proposals that are able to derive the pair-list reading without movement of the second *wh*-phrase. In order to avoid confusion it should be pointed out that the notion of ordered pair used above of course refers to the specific case of just two *wh*-phrases. The notion of n-tuple would have been more appropriate in order to include cases with three or more *wh*-phrases such as (241a), but we will follow the general practice of simply using the notion pair-list reading.

- (241) a. WIE heeft WAT aan WIE gegeven?  
 who has what to whom given  
 ‘Who has given what to whom?’  
 b. ? $\langle x, y, x \rangle$  (x has given y to z)

Example (242a) shows that multiple questions need not be main clauses but can also be embedded. An informal semantic representation of this example is given in (242b): John wondered for which ordered pairs  $\langle x, y \rangle$  it is true that x has read y.

- (242) a. Jan vroeg zich af [WIE WAT heeft gelezen].  
 Jan wondered REFL prt who what has read  
 ‘Jan wondered who has read what.’  
 b. Jan wondered: ? $\langle x, y \rangle$  (x has read y)

The *wh*-phrases in (240a), (241a) and (242a) are clause-mates, but this is not necessary: example (243a) shows that the second *wh*-phrase can also be more deeply embedded. This example again has a pair-list reading, which is given in (243b). A proper answer should provide a list of pairs  $\langle x, y \rangle$  such that it is true that x says that Peter is reading y: Marie says that Peter is reading *Max Havelaar*, Jan says that Peter is reading *De Kapellekensbaan*, etc.

- (243) a. WIE zegt [dat Peter WAT leest]?  
 who says that Peter what reads  
 ‘Who says that Peter is reading what?’  
 b. ? $\langle x, y \rangle$  (x says that Peter is reading y)

It is important to note that pair-list readings do not arise if the second *wh*-phrase occupies a scope position itself. This is illustrated in (244), in which *wat* ‘what’ is *wh*-moved into the initial position of the embedded clause (as indicated by the trace; note that we do not indicate the trace of the matrix subject *who* for the sake of simplicity of representation). Examples like these can only be interpreted as in (244b); proper answers to such questions identify the agent of the matrix verb, but not the theme of the embedded verb: *Marie* (*vroeg zich af wat Peter leest*) ‘Marie (wondered what Peter is reading)’.

- (244) a. Wie vroeg zich af [wat<sub>i</sub> Peter t<sub>i</sub> leest]?  
 who wondered REFL prt. what Peter reads  
 ‘Who wonders what Peter is reading?’  
 b. ?x (x wondered: ?y (Peter is reading y))

Multiple questions do not only have a special meaning but also a characteristic intonation pattern: both *wh*-phrases must be accented, which has been indicated in the examples above by small caps. This will help us to distinguish multiple *wh*-questions from regular *wh*-questions like the primeless examples in (245), in which the unaccented pronoun *wat* is interpreted existentially, that is, with the meaning ‘something’. This results in the informal semantic representations given in the primeless examples.

- (245) a. WIE heeft (er) wat gelezen?  
 who has there something read  
 ‘Who has read something?’  
 a’.  $?x \exists y$  (x has read y)  
 b. Jan vroeg zich af [WIE (er) wat heeft gelezen].  
 Jan wondered REFL prt. who there something has read  
 ‘Jan wondered who has read something.’  
 b’. Jan wondered:  $?x \exists y$  (x has read y)

The examples in (245a&b) also show that it is possible to include the expletive *er* ‘there’ in regular questions, which is consistent with the fact that the non-D-linked subject pronoun *wie* ‘who’ is compatible with it; cf. *Wie komt er?* ‘Who is coming?’. Although judgments are subtle, it seems clear to us that adding the expletive to multiple questions like (240a)/(242a) is more difficult. If the judgments on the resulting examples in (246) are indeed correct, this suggests that *wh*-phrases in multiple questions are (to a certain extent) D-Linked. This would of course fit in nicely with the pair-list readings of such questions, as these seem to involve entities from the domain of discourse. We leave this suggestion for future research.

- (246) a.  $?WIE$  heeft er WAT gelezen?  
 who has there what read  
 ‘Who has read what?’  
 b.  $?Jan$  vroeg zich af [WIE er WAT heeft gelezen].  
 Jan wondered REFL prt. who there what has read  
 ‘Jan wondered who has read what.’

## II. Syntactic function of the *wh*-phrases

The *wh*-phrases in the examples given in Subsection I are all arguments. The examples in (247) show more specifically that the subject may form a pair with the direct object, the indirect object, or a triple with both objects.

- (247) a. WIE heeft WAT aan Peter gegeven?  
 who has what to Peter given  
 ‘Who has given what to Peter?’  
 b. WIE heeft zijn boek aan WIE gegeven?  
 who has his book to whom given  
 ‘Who has given his book to whom?’  
 c. WIE heeft WAT aan WIE gegeven?  
 who has what to whom given  
 ‘Who has given what to whom?’

The examples in (248) show that the subject need not be involved; the pair may also involve two objects; the two examples in (248) illustrate this for constructions with respectively a nominal and a prepositional indirect object.



- (248) a. WIE heeft Jan/hij WAT gegeven?  
 who has Jan/he what given  
 ‘Who has Jan/he given what?’  
 b. WAT heeft Jan/hij aan WIE gegeven?  
 what has Jan/he to whom given  
 ‘What has Jan/he given to whom?’

The fact illustrated above that *in situ wh*-phrases can be embedded in prepositional indirect objects raises the expectation that they can also be embedded in prepositional objects. The examples in (249) shows that this prediction is borne out. It should be noted that the acceptability of example (249b) is special in that the sequence *op wat* ‘for what’ is normally replaced by the pronominal PP *waarop* ‘for what’ in (249b’), but a Google search (7/17/2014) shows that both sentences occur on the internet; the number of results, which have been manually checked, are given within square brackets.

- (249) a. WIE wacht op WIE?  
 who waits for who  
 ‘Who is waiting for whom?’  
 b. WIE wacht op WAT? [3 hits]  
 who waits for what  
 ‘Who is waiting for what?’  
 b’. WIE wacht WAAR op? [9 hits]  
 who waits where for  
 ‘Who is waiting for what?’

Given the special nature of the (b)-examples in (249) we will provide one more example of this alternation with the phrasal verb *recht hebben (op)* ‘to be entitled to’ in (250). Both forms occur relatively frequently on the internet; the raw results of our Google search (7/17/2014) are again given within square brackets. Example (250b) is interesting in its own right, as it shows that the R-pronoun *waar* is preferably moved leftward (the non-split pattern does occasionally occur on the internet but is much less frequent). This shows that the earlier claim that the second *wh*-phrase remains *in situ* is only true in as far as it cannot undergo *wh*-movement.

- (250) a. WIE heeft recht op WAT? [36 hits]  
 who has right to what  
 ‘Who is entitled to what?’  
 b. WIE heeft WAAR recht op? [51 hits]  
 who has right to what  
 ‘Who is entitled to what?’

Multiple *wh*-questions are not affected by the location of the prepositional object (cf. Koster (1987:213); the primeless examples in (251) show that the object *op wie/wat* can occur before or after the main verb in clause-final position; example (251b’) shows that in the case of the pronominal PP *waarop*, the placement before the main verb seems to give a better result.

- (251) a. WIE heeft <op WIE> gewacht <op WIE>?  
 who has for who waited  
 ‘Who has waited for whom?’
- b. WIE heeft <op WAT> gewacht <op WAT>?  
 who has for who waited  
 ‘Who has waited for what?’
- b’. WIE heeft <WAARop> gewacht <?waarOP>?  
 who has for.what waited  
 ‘Who has waited for what?’

Multiple *wh*-questions are also possible with *wh*-adjuncts. This holds especially for spatial *waar* ‘where’ and temporal *wanneer* ‘when’, but it is also at least marginally possible for adjuncts like *waarom* ‘why’ and *hoe* ‘how’ (the latter are impossible in English if the first *wh*-phrase is a subject; see Lasnik & Saito 1992:ch.1). In order to give an indication of the relative frequency of these cases, we give the raw results of our Google search (7/17/2014) on the string [*wie heeft waar/wanneer/waarom/hoe*] within square brackets. The results for *hoe* are rather flattering as they include many cases in which *hoe* functions as a degree modifier but natural examples do occur; (252c) is in fact taken from the internet.

- (252) a. WIE heeft WAAR/WANNEER geslapen? [245/242 hits]  
 who has where/when slept  
 ‘Who has slept where/when?’
- b. WIE heeft WAAROM geklaagd? [28 hits]  
 who has why complained
- c. WIE heeft HOE gestemd? [23 hits]  
 who has how voted

Haider (2010: Section 3.4) claims that the difference between English and Dutch (and German) is a more general difference between VO- and OV-language. Haider also notes that adverbs like *waar* ‘where’ and *wanneer* ‘when’ can co-occur in multiple questions, while adverbs like *waarom* ‘why’ and *hoe* ‘how’ cannot (regardless of their order); we illustrate this in (253).

- (253) a. WANNEER heb je WAAR geslapen?  
 when have you where slept  
 ‘When have you slept where?’
- b. \*WAAROM heb je de televisie HOE gerepareerd?  
 why have you the television how repaired
- b’. \*HOE heb je de televisie WAAROM gerepareerd?  
 how have you the television why repaired

Note that the (b)-examples are fully acceptable if the second *wh*-phrase is omitted, so that we must be dealing with a co-occurrence restriction on *waarom* and *hoe*; we refer the reader to Haider (2010:119ff.) for the claim that this restriction is universal and should be related to the semantic type of these adverbial phrases.

### III. Island-sensitivity

Subsection I mentioned that the fact that the second (third, etc.) *wh*-phrase is left *in situ* has led to the claim that it undergoes covert (invisible) movement. A serious problem for this claim is that the second *wh*-phrase may occur in various positions in which traces of *wh*-phrases normally cannot. We will illustrate this here for a number of islands that are strong in Dutch; see Section 11.3.1.3. In order to not complicate the discussion unnecessarily, we confine ourselves to *wh*-phrases functioning as arguments.

#### A. Embedded questions

The examples in (254) show first that while long *wh*-movement from an embedded *yes/no*-question is impossible, it is fairly easy to associate a *wh*-phrase embedded in a *yes/no*-question with a *wh*-phrase in the matrix clause. Example (254a) again requires a pair-list answer: Marie wonders whether Peter is reading *Max Havelaar*, Jan wonders whether Peter is reading *De Kapellekensbaan*, etc.

- (254) a. WIE vraagt zich af [of Peter WAT leest]?  
 who wonders REFL prt. if Peter what reads  
 ‘Who wonders whether Peter is reading what?’  
 b. \*Wat<sub>i</sub> vraagt Jan zich af [of Peter t<sub>i</sub> leest]?  
 what wonders Jan REFL prt whether Peter reads

The examples in (255) provide similar examples with embedded *wh*-questions; while long *wh*-movement from an embedded *yes/no*-question is impossible, it is again fairly easy to associate a *wh*-phrase embedded in a *wh*-question with a *wh*-phrase in the matrix clause. Since the embedded subject *who* is in a scope position and so does not participate in the multiple question (see the discussion of (244a) in Subsection I), (255a) requires a pair-list reading of the following type: Marie wonders who read *Max Havelaar*, Jan wonders who read *De Kappelekensbaan*, etc.

- (255) a. WIE vroeg zich af [WIE WAT leest]?  
 who wonders REFL prt. who what reads  
 ‘Who wonders who is reading what?’  
 b. \*Wat<sub>i</sub> vroeg Jan zich af [wie t<sub>i</sub> leest]?  
 who wonders Jan REFL prt. who reads

For completeness’ sake, observe that (255a) is ambiguous. It can also be interpreted as a regular question with an embedded multiple question: ?x wondered: ?<y,z> (y has read z). On this interpretation, the question can simply be answered by a single noun phrase: *Marie* (*vroeg zich af wie wat leest*) ‘Marie (wondered who is reading what)’.

#### B. Adjunct clauses

The examples in (256) show that while long *wh*-movement from an adjunct clause is impossible, it is fairly easy to associate a *wh*-phrase embedded in an adjunct clause with a *wh*-phrase in the matrix clause. Note in passing that the adjunct follows the complementive *jaloers* and must therefore be in clause-final position.

- (256) a. WIE werd jaloers [nadat Peter WAT gekregen had]?  
 who became jealous after Peter what gotten had  
 ‘Who became jealous after Peter had gotten what?’  
 b. \*Wat<sub>i</sub> werd Jan jaloers [nadat Peter t<sub>i</sub> gekregen had]?  
 what became Jan jealous after Peter gotten had

### C. Complex noun phrase

The examples in (257) show that while long *wh*-movement from a complement clause of a noun is impossible, it is fairly easy to associate a *wh*-phrase embedded in such a complement clause with a *wh*-phrase in the matrix clause. Observe that the complement clause need not be adjacent to the noun but may also be placed in clause-final position: cf. *WIE heeft het gerucht verspreid [dat Peter WAT gezegd had]*.

- (257) a. WIE heeft [het gerucht [dat Peter WAT gezegd had]] verspreid?  
 who has the rumor that Peter what said had spread  
 ‘Who has spread the rumor that Peter had said what?’  
 b. \*Wat<sub>i</sub> heeft Jan [het gerucht [dat Peter t<sub>i</sub> gezegd had]] verspreid?  
 what has Jan the rumor that Peter said had spread

We expect similar judgments for examples like (258) with relative clauses but our informants seem to have difficulties with examples like (258a); the contrast with (258b) is still clear, however.

- (258) a. %WIE kent [de man [die WAT gezegd had]]?  
 who knows the man REL what said had  
 ‘Who knows the main who said what?’  
 b. \*Wat kent Jan [de man [die t<sub>i</sub> gezegd had]]?  
 what knows Jan the man REL said had

For completeness’ sake, the examples in (259) are added to show that simple noun phrases that uncontroversially block *wh*-extraction of their PP-complement do not block the association of a *wh*-phrase with the subject of the matrix clause. Observe that the PP-complement may also be in extraposed position; cf. *WIE zal morgen zijn klacht intrekken tegen WIE?*

- (259) a. WIE zal morgen [zijn klacht [tegen WIE]] intrekken?  
 who will tomorrow his complaint against who withdraw  
 ‘Who will withdraw his complaint against who tomorrow?’  
 b. \*[Tegen wie]<sub>i</sub> zal Jan [zijn klacht t<sub>i</sub>] morgen intrekken?  
 against who will Jan his complaint tomorrow withdraw

### D. Coordinate structures

Coordinate structures differ from the strong islands discussed in the previous subsections in that they do not allow embedding of the *in situ wh*-phrase. The (a)- and (b)-examples are all unacceptable, the only option being replacement of the full coordinate structure by a single *wh*-phrase, as in the (c)-examples.

- (260) a. \*Wie heeft [[een boek] en [wat]] gekocht?  
 who has a book and what bought  
 a'. \*Wat<sub>i</sub> heeft Jan [[een boek] en [ t<sub>i</sub>]] gekocht?  
 what has Jan a book and bought  
 b. \*Wie heeft [[wat] en [een CD]] gekocht?  
 who has what and a CD bought  
 b'. \*Wat<sub>i</sub> heeft Jan [[ t<sub>i</sub>] en [een CD]] gekocht?  
 what has Jan and a CD bought  
 c. WIE heeft WAT gekocht?  
 who has what bought  
 'Who has bought what?'  
 c'. Wat<sub>i</sub> heeft Jan t<sub>i</sub> gekocht?  
 what has Jan bought  
 'What has Jan bought?'

### E. Conclusion

The multiple *wh*-questions in the first three subsections above are all rated as being fully grammatical, although it may be that some speakers have problems with them for reasons related to their complexity. However, what is at stake here are the relative acceptability contrasts with the fully unacceptable *wh*-extraction cases, which all native speakers of Dutch will be able to replicate; see Bayer (2006:389) for similar pairs from German. We may therefore conclude that strong islands may normally embed the second (third, etc) *wh*-phrase in multiple *wh*-questions, with one notable exception: embedding the second *wh*-phrases in a coordinate structure is impossible. The fact that the formation of a multiple *wh*-question is normally not island-sensitive can be seen as an argument against the covert *wh*-movement approach of generative grammar from the 1980's, which found its more or less definite form in Lasnik & Saito (1992); we refer the reader to the seminal work in Hornstein (1995) for a relatively early argument in favor of eliminating covert movement from the theory.

### IV. Superiority condition

Multiple questions with interrogative pro-forms like *wat* 'what' and *waar* 'where' seem to adhere to fairly strict order restrictions in the sense that the canonical word order is not affected by *wh*-movement. The examples in (261) show that in transitive constructions the subject normally precedes the direct object, just as in declarative clauses such as *dat* <\**dat boek*> *Jan* <*dat boek*> *gekocht heeft* (which we give here in its embedded form to eliminate the interference of topicalization).

- (261) a. WIE<sub>Subject</sub> heeft WAT<sub>DO</sub> gekocht?  
 who has what bought  
 'Who has bought what?'  
 b. \*?WAT<sub>DO</sub> heeft WIE<sub>Subject</sub> gekocht?  
 what has who bought

It is worth noting that examples like (261b) are claimed to be acceptable in German (cf. Haider (2010:115), which may be due to the fact that the order of subjects and objects is less strict in German than in Dutch.

For ditransitive constructions the tendency to preserve the unmarked order in multiple *wh*-questions means that the order of the nominal arguments will be: subject > indirect object > direct object. We illustrate this in (262) for multiple *wh*-questions based on the reference sentence *dat Jan/Hij Marie/haar een boek wil geven* ‘that Jan/he wants to give Marie/her a book’. The asterisk in (262b’) indicates that the intended interpretation is not available.

- (262) a. WIE<sub>Subject</sub> wil Marie/haar<sub>IO</sub> WAT<sub>DO</sub> geven? [subject > direct object]  
 who wants Marie/her what give  
 a’. \*WAT<sub>DO</sub> wil WIE<sub>Subject</sub> Marie/haar<sub>IO</sub> geven?  
 b. WIE<sub>Subject</sub> wil WIE<sub>IO</sub> een boek<sub>DO</sub> geven? [subject > indirect object]  
 who want who a book give  
 b’. \*WIE<sub>IO</sub> wil WIE<sub>Subject</sub> een boek geven?  
 c. WIE<sub>IO</sub> wil Jan/hij<sub>Subject</sub> WAT<sub>DO</sub> geven? [indirect object > direct object]  
 who wants Jan/he what give  
 c’. ??WAT<sub>DO</sub> wil Jan/hij<sub>Subject</sub> WIE<sub>IO</sub> geven?

Subjects and direct objects tend to precede prepositional indirect objects in multiple *wh*-questions, although speakers seem to be less rigid in this case. We illustrate this in (263) for questions based on the reference sentence *dat Jan een boek aan Marie wil geven* ‘that Jan wants to give a book to Marie’. The fairly acceptable status of (263b’) might be related to the fact that the prepositional indirect object may precede direct objects in focus constructions; cf. *dat Jan aan Marie een BOEK wil geven*.

- (263) a. WIE<sub>Subject</sub> wil een boek aan WIE<sub>IO</sub> geven? [subject > prepositional IO]  
 who wants a book to whom give  
 a’. ??Aan WIE<sub>IO</sub> wil WIE<sub>Subject</sub> een boek geven?  
 b. WAT<sub>DO</sub> wil Jan aan WIE<sub>IO</sub> geven? [direct object > prepositional IO]  
 what wants Jan to whom give  
 b’. ?Aan WIE<sub>IO</sub> wil Jan WAT<sub>DO</sub> geven?

NOM-DATIVE verbs normally allow the °DO-subject and the indirect object to occur in both orders and this also seems to hold for multiple *wh*-questions with these verbs. We show this in (264) for questions based on the reference sentence *dat <dat boek> Peter <dat boek> goed is bevallen* ‘that that book pleases Peter much’. One should be aware that examples of this kind cannot be used to argue that Dutch is like German in that it does not impose any ordering restrictions on the subject and the object in multiple *wh*-questions.

- (264) a. WAT<sub>Subject</sub> is WIE<sub>IO</sub> goed bevallen? [DO-subject > indirect object]  
 what is who well pleased  
 ‘What has pleased who much?’  
 b. WIE<sub>IO</sub> is WAT<sub>Subject</sub> goed bevallen? [indirect object > DO-subject]  
 who is what well pleased

Subjects and direct objects normally precede prepositional objects, and (265) shows that this order is maintained in multiple *wh*-questions. The (a)-examples are based on the reference sentence *dat Jan op zijn vader wacht* ‘that Jan is waiting for his

father' and the (b)-examples on the reference sentence *dat de rechter Peter tot het betalen van een boete veroordeelde* 'that the judge sentenced Peter to pay a fine'.

- (265) a. WIE<sub>Subject</sub> wacht op WIE<sub>PO</sub>? [subject > prepositional object]  
 who waits for who  
 'Who is waiting for who?'  
 a'. <sup>??</sup>Op WIE<sub>PO</sub> wacht WIE<sub>Subject</sub>?  
 b. WIE<sub>DO</sub> veroordeelde de rechter tot WAT<sub>PO</sub>? [direct object > prep. object]  
 who sentenced the judge to what  
 'Who did the judge sentence to what?'  
 b'. <sup>\*?</sup>Tot WAT<sub>PO</sub> veroordeelde de rechter wie<sub>DO</sub>?

Subjects normally also precede spatial/temporal adverbial phrases. Although there may be a slight preference for objects to precede such adjuncts, both orders seem to be acceptable in multiple *wh*-questions, which is in line with the fact that the order of objects and spatial/temporal adverbial phrases also varies in the middle field of the clause: *dat hij <de man> gisteren/in Amsterdam <de man> heeft ontmoet* 'that he met the man yesterday/in Amsterdam'.

- (266) a. WIE<sub>Subject</sub> heeft hem<sub>DO</sub> WAAR/WANNEER ontmoet? [subject > adjunct]  
 who has him where/when met  
 a'. <sup>??</sup>WAAR/WANNEER heeft WIE<sub>Subject</sub> hem<sub>DO</sub> ontmoet?  
 b. Wie<sub>DO</sub> heeft hij WAAR/WANNEER ontmoet? [direct object > adjunct]  
 who has he where/when met  
 b'. <sup>(?)</sup>WAAR/WANNEER heeft hij WIE<sub>DO</sub> ontmoet? [adjunct > direct object]  
 where/when has he who met

The generalization that seems to cover all the cases above is that the *wh*-phrase whose canonical position is closest to the clause-initial position will be the one that undergoes *wh*-movement. This generalization may perhaps follow from some version of Chomsky's (1973) SUPERIORITY CONDITION (in which <sup>o</sup>superiority refers to asymmetric <sup>o</sup>c-command) if we adopt the view that linear order is ultimately derived from the structural, hierarchical relation between phrases; see Kayne (1994) for an influential formalization of this idea. We will not explore this option here, but simply use the notion of superiority condition as a convenient label for the generalization mentioned above.

Although the superiority condition provides a relatively adequate description of the order of the interrogative pro-forms in the earlier examples, it seems to run afoul of cases involving more complex *wh*-phrases. This can be illustrated fairly easily by means of examples with a complex *wh*-subject and a complex *wh*-object; many speakers allow both order orders in (267). We refer the reader to Dayal (2006: Section 2) for a review of similar facts from English.

- (267) a. WELKE student heeft WELK boek gelezen?  
 which student has which book read  
 'Which student has read which book?'  
 b. <sup>%</sup>Welk boek heeft welke student gelezen?  
 which book has which student read  
 'Which book has which student read?'



11.3.2. *Relative clauses*

This section discusses the role of as well as the restrictions on *wh*-movement in the formation of relative clauses (henceforth: relativization). Example (268) shows that relativization involves movement of some relative element such as the relative pronoun *die* ‘who’ into the initial position of the relative clause; as a result, the relative element immediately follows its antecedent.

- (268) [De man [die<sub>i</sub> ik gisteren  $t_i$  ontmoet heb]] is vertrokken.  
 the man who I yesterday met have is left  
 ‘The man who I met yesterday has left.’

This section is relatively brief since the reader will find an extensive discussion of relative clauses in Section N3.3.2, so that there is little need to digress on side issues. For example, it is shown there that there are virtually no restrictions on the syntactic function or the form of the *wh*-moved relative element; as in the case of question formation, relativization allows any clausal constituent to undergo *wh*-movement provided that a proper relative form is available. We will therefore focus on the movement behavior of these relative elements. Subsection I starts by showing that *wh*-movement of the relative element is obligatory: it is not possible to leave it *in situ*. Subsection II discusses °pied piping and °stranding. Subsection III continues with a number of cases in which the relative element undergoes long *wh*-movement, and also discusses a number of island configurations. Subsection IV concludes with a brief discussion of so-called cleft constructions like *Het is Peter [die ik wil spreken]* ‘It is Peter who I want to speak’, as the internal structure of embedded clauses in such constructions resembles relative clauses quite closely.

The overall conclusion of the following discussion will be that *wh*-phrases and relative elements exhibit similar movement behavior in most respects. There are, however, two important differences that we will mention here. First, *wh*-movement of relative elements applies in embedded clauses only, which is simply due to the fact that relative clauses are constituents within a noun phrase. Second, since relative clauses have at most one antecedent, they also have at most one relative element: there is no such thing as a multiple relative construction.

I. *Wh-movement of the relative element is obligatory*

There are good reasons for assuming that relative elements are like *wh*-phrases in that they are moved into the position preceding the complementizer. This cannot be shown for Standard Dutch, however, because the phonetic content of the complementizer is obligatorily elided in relative clauses, as is indicated in (269a) by strikethrough. It is nevertheless quite plausible, as many Flemish and Frisian dialects do allow the complementizer to be overtly expressed; see Pauwels (1958), Dekkers (1999:ch.3), Barbiers et al. (2005:section 1.3.1), Boef (2013:ch.3), and the references cited there. Example (269b) shows that movement of the relative element is obligatory; leaving it *in situ* results in ungrammaticality.

- (269) a. [De man [<sub>CP</sub> die<sub>i</sub> ~~dat~~ [<sub>IP</sub> ik gisteren *t<sub>i</sub>* ontmoet heb]]] is vertrokken.  
 the man who that I yesterday met have is left  
 ‘The man who I met yesterday has left.’
- b. \*[De man [<sub>CP</sub> dat [<sub>IP</sub> ik gisteren *die* ontmoet heb]]] is vertrokken.  
 the man that I yesterday who met have is left

The obligatoriness of movement can again be motivated semantically by assuming that *wh*-movement of the relative element creates an open proposition (that is, a one-place predicate) which can be used to modify the head noun. On this view, a relative clause is semantically similar to an attributive modifier like *boze* in *de boze man* ‘the angry man’, which is likewise a one-place predicate. This more or less classical idea is attractive, of course, given that it suggests that the role of *wh*-movement in question formation and relativization can be unified. Although there is currently a debate going on about the question as to whether the derivation of relative clauses given in (269) is fully correct, we will simply assume that the suggested semantic motivation for *wh*-movement in relative clauses is on the right track and that any syntactic account of relativization should be able to accommodate it in order to be tenable; we refer to Bianchi (1999), De Vries (2002:ch.4) and Salzmann (2006:ch.1) for extensive reviews of the debate mentioned above.

## II. Pied piping and stranding

If *wh*-movement in relative clauses is indeed motivated by the need to create an open proposition, we would again expect that it is precisely the relative element that must be moved into clause-initial position. This raises the question as to whether *wh*-movement will trigger pied piping if syntactic constraints prohibit extraction. The examples in (270) show that this is indeed the case: as *wh*-movement of the italicized relative element would suffice to create the wanted open predicate, pied piping of the larger phrase should be motivated by appealing to a syntactic restriction that prohibits extraction of the relative element from the noun phrase *wiens vader* ‘whose father’.

- (270) a. [De jongen [[<sub>NP</sub> *wiens vader*]; ik gisteren *t<sub>i</sub>* ontmoet heb]] is ziek.  
 the boy whose father I yesterday met have is ill  
 ‘The boy whose father I met yesterday is ill.’
- b. \*[De jongen [*wiens<sub>i</sub>* ik gisteren [<sub>NP</sub> *t<sub>i</sub>* vader] ontmoet heb]] is ziek.  
 the boy whose I yesterday father met have is ill

The restrictions on extraction of relative elements are more or less the same as those on extraction on *wh*-elements. In order to avoid a full repetition of the discussion on stranding and pied piping in Section 11.3.1.1, we will illustrate this for PPs only. The examples in (271) first show that *prepositional* objects like *naar wie* ‘at who’ require pied piping. However, if the PP has the pronominalized form *waarnaar* (which is easier to get for human entities in relative clauses than in *wh*-questions as the result of the presence of an antecedent with the feature [+HUMAN]) stranding is possible and may even be preferred (although we do not have frequency data available to corroborate this).

- (271) a. [De jongen [[<sub>PP</sub> naar *wie*]<sub>i</sub> je *t*<sub>i</sub> kijkt]] is mijn broer.  
 the boy at who you look is my brother  
 ‘The boy you are looking at is my brother.’
- a'. \*[De jongen [*wie*<sub>i</sub> je [<sub>PP</sub> naar *t*<sub>i</sub>] kijkt]] is mijn broer.  
 the boy who you at look is my brother
- b. <sup>(2)</sup>[De jongen [[<sub>PP</sub> *waar* naar]<sub>i</sub> je *t*<sub>i</sub> kijkt]] is mijn broer.  
 the boy where at you look is my brother  
 ‘The boy you are looking at is my brother.’
- b'. [De jongen [*waar*<sub>i</sub> je [<sub>PP</sub> *t*<sub>i</sub> naar] kijkt]] is mijn broer.  
 the boy where you at look is my brother

The examples in (272) show the same thing for *prepositional* complementives; see P4.2.1.1 for extensive discussion of the fact that verbs of location like *zitten* ‘to sit’ take a complementive. If the complement of the preposition is the interrogative pronoun *wie*, pied piping is obligatory, whereas stranding seems to be the preferred option in the case of pronominal PPs.

- (272) a. De kat zit [<sub>PP</sub> bij Peter].  
 the cat sits with Peter  
 ‘The cat is sitting with Peter.’
- b. De man [[<sub>PP</sub> bij *wie*]<sub>i</sub> de kat *t*<sub>i</sub> zit] is mijn broer.  
 the man with who the cat sits is my brother  
 ‘The man the cat is sitting with is my brother.’
- b'. \*De man [*wie*<sub>i</sub> de kat [<sub>PP</sub> bij *t*<sub>i</sub>] zit] is mijn broer.  
 the man who the cat with sits is my brother
- c. <sup>3</sup>De man [[<sub>PP</sub> *waar*<sub>i</sub> bij] de kat *t*<sub>i</sub> zit] is mijn broer.  
 the man where with the cat sits is my brother  
 ‘The man the cat is sitting with is my brother.’
- c'. De man [*waar*<sub>i</sub> de kat [<sub>PP</sub> *t*<sub>i</sub> bij] zit] is mijn broer.  
 the man where the cat with sits is my brother

*Postpositional* complementives differ from *prepositional* ones in that they do not allow pied piping but require stranding of the postposition. We illustrate this in (273) by means of the complementive *de boom in* ‘into the tree’.

- (273) a. De kat is [<sub>PP</sub> de boom in] geklommen.  
 the cat is the tree into climbed  
 ‘The cat has climbed into the tree.’
- b. De boom [*die*<sub>i</sub> de kat [<sub>PP</sub> *t*<sub>i</sub> in] geklommen is] is heel groot.  
 the tree which the cat into climbed is is very big  
 ‘The tree which the cat has climbed into is very big.’
- b'. \*De boom [[*die* in]<sub>i</sub> de kat *t*<sub>i</sub> geklommen is] is heel groot.  
 the tree which into the cat climbed is is very big

The examples in (274), finally show that *circumpositional* complementives such as *tussen wie door* must be split: the first member of the circumposition plus the *wh*-phrase *tussen wie* is preposed while the second member *door* stays *in situ*.

- (274) a. Jan is [tussen de bewakers door] geglipt  
 Jan is between the guards DOOR slipped  
 ‘Jan has slipped past between the guards.’  
 b. de bewakers [[tussen wie]<sub>i</sub> Jan [<sub>t<sub>i</sub></sub> door] is geglipt]  
 the guards between who Jan DOOR is slipped  
 ‘the guards between whom Jan has slipped past’  
 b’. \*de bewakers [tussen wie door]<sub>i</sub> Jan <sub>t<sub>i</sub></sub> is geglipt]  
 the guards between who DOOR Jan is slipped

The judgments on the examples above show that, as in questions, pied piping and stranding are more or less in complementary distribution; the formation of *wh*-questions and relativization seem in fact to exhibit essentially the same pattern. This suggests that we will be able to account for the examples in (271)–(274) by adopting the set of assumptions from Section 11.3.1.1, sub VI, including the “avoid pied piping” constraint; We refer the reader to this subsection for the general line of reasoning, which can be straightforwardly applied to the examples in (271) to (274).

### III. Long *Wh*-movement and islands

Relativization is compatible with long *wh*-movement: we illustrate this in example (275) for a direct object and an adverbial phrase extracted from an object clause.

- (275) a. de man [die<sub>i</sub> ik dacht [dat jij <sub>t<sub>i</sub></sub> gesproken had]]  
 the man who I thought that you spoken had  
 ‘the man who I thought that you had spoken with’  
 b. de stad [waar<sub>i</sub> ik denk [dat jij Jan <sub>t<sub>i</sub></sub> zal ontmoeten]]  
 the city where I think that you Jan will meet  
 ‘the city where I think that you will meet Jan’

As in the case of *wh*-question formation, long *wh*-movement is only possible from argument clauses; the examples in (276) show that adjunct clauses prohibit extraction of both arguments and adjuncts and should therefore be considered strong islands for *wh*-movement of relative elements.

- (276) a. Ik vertrek [nadat jij je lezing gegeven hebt].  
 I left after you your talk given have  
 ‘I’ll leave after you’ve presented your lecture.’  
 a’. \*de lezing [die<sub>i</sub> ik vertrek [nadat jij <sub>t<sub>i</sub></sub> gegeven hebt]]  
 the talk which I leave after you given have  
 Compare: ‘\*the talk which I will leave after you’ve presented’  
 b. Ik vertrek [voordat jij in Amsterdam aankomt].  
 I depart before you in Amsterdam arrive  
 ‘I’ll depart before you arrive in Amsterdam.’  
 b’. \*de stad [waar<sub>i</sub> ik vertrek [voordat jij <sub>t<sub>i</sub></sub> aankomt]]  
 the city where I depart before you arrive  
 Compare: ‘\*the city where I’ll depart before you arrive’

Long *wh*-movement requires that the matrix clause contains a so-called bridge verb. Example (277b) shows for *wh*-questions that while long *wh*-movement is fully acceptable with the verb *zeggen* ‘to say’, it is not easily possible with verbs of

saying that express a manner component like *schreeuwen* ‘to yell’. Example (277c) shows that we find the same contrast with long *wh*-movement in relative clauses.

- (277) a. Marie zegt/schreeuwt [dat Peter een auto gestolen heeft].  
 Marie says/yells that Peter a car stolen has  
 ‘Marie says/yells that Peter has stolen a car.’
- b. Wat<sub>i</sub> zegt/\*schreeuwt Marie [dat Peter t<sub>i</sub> gestolen heeft]?  
 what says/yells Marie that Peter stolen has  
 ‘What does Marie say that Peter has stolen?’
- c. de auto [die Marie zegt/\*schreeuwt [dat Peter t<sub>i</sub> gestolen heeft]]  
 the car which Marie says/yells that Peter stolen has  
 ‘the car which Marie says that Peter has stolen’

It seems, however, that the set of bridge verbs is not identical for the two constructions. While Section 11.3.1.2 has shown that object clauses selected by factive verbs like *weten* ‘to know’ are weak islands for long *wh*-movement in *wh*-questions, this does not seem to hold for long *wh*-movement in relative clauses. A corpus of long *wh*-movement constructions manually collected by Jack Hoeksema in fact shows that *weten* is the most frequent bridge verb in relative clauses derived by long *wh*-movement; cf. Table 5.2 in Schippers (2012). Although Schippers does not give concrete examples that illustrate the bridge function of *weten*, a Google search (7/27/2014) on the search string [*die ik wist dat*] shows that this construction is indeed relatively frequent; the examples in (278) provide two attested examples. Observe that example (278a) seems to show that long *wh*-movement of subject pronouns does not give rise to the °complementizer-trace effect in relative clauses for at least some speakers; see also Van der Auwera (1984), Boef (2013:35), and Coppen (2013).

- (278) a. Er is niemand [...] [die<sub>i</sub> ik weet [dat t<sub>i</sub> dat doet]].  
 that is nobody who I know that that does
- b. Er zijn twee dingen [die<sub>i</sub> ik weet [dat ik t<sub>i</sub> niet moet doen]].  
 there are two things that I know that I not should do  
 ‘There are two things which I know I shouldn’t do.’

It should be noted, however, that speakers seem to differ in their appreciation of relative clauses with long *wh*-movement. Salzmann (2006:153), for example, notes that some speakers prefer resumptive prolepsis constructions like (279) to long *wh*-movement constructions like (278).

- (279) a. Er is niemand [...] [van wie<sub>i</sub> ik weet [dat hij dat doet]].  
 there is nobody of who I know that he that does  
 ‘There is nobody of whom I know that he is doing that.’
- b. Er zijn twee dingen [waar<sub>i</sub>-van ik weet [dat ik ze<sub>i</sub> niet moet doen]].  
 there are two things which-of I know that I them not should do  
 ‘There are two things which I know I shouldn’t do.’

The island-sensitivity of *wh*-questions and relative clauses does not differ when it comes to strong islands. We will illustrate this here for embedded questions only. Example (280a) involves an embedded polar *yes/no* question and (280b) shows that

such clauses block long *wh*-movement of relative elements; the competing resumptive prolepsis construction in (280c) does give rise to an acceptable result. The examples in (281) show the same by means of an embedded *wh*-question.

- (280) a. Ik vroeg me af [of Jan dat boek gelezen had].  
 I asked REFL prt. if Jan that book read had  
 'I wondered whether Jan had read that book.'
- b. \*het boek [dat<sub>i</sub> ik me afvroeg [of Jan t<sub>i</sub> gelezen had]]  
 the book which I REFL prt.-wondered if Jan read had
- c. het boek [waar<sub>i</sub>-van ik me afvroeg [of Jan het<sub>i</sub> gelezen had]]  
 the book which-of I REFL prt.-wondered if Jan it read had  
 'the book about which I was wondering whether Jan had read it'
- (281) a. Ik vroeg me af [wie dat boek gelezen had].  
 I asked REFL prt. who that book read had  
 'I wondered who had read that book.'
- b. \*het boek [dat<sub>i</sub> ik me afvroeg [wie t<sub>i</sub> gelezen had]]  
 the book which I REFL prt.-wondered who read had
- c. het boek [waar<sub>i</sub>-van ik me afvroeg [wie het<sub>i</sub> gelezen had]]  
 the book which-of I REFL prt.-wondered who it read had  
 'the book about which I was wondering who had read it'

#### IV. Cleft and pseudo-cleft constructions

This subsection briefly discusses *wh*-movement in so-called cleft and pseudo-cleft constructions. The cleft construction illustrated in (282a) is characterized by the fact that it involves the subject pronoun *het* 'it', a contrastively focused complementive (here: *je vriend*) and a clause that closely resembles a relative clause. However, the clause does not function as a modifier of the complementive, as is clear from the fact that it neither restricts the denotation of the head noun *vriend* 'friend' nor provides additional information about the referent of the definite noun phrase *je vriend* 'your friend'. Instead, examples like (282a) express identity statements: the person who stole the book is identified as your friend. That we are not dealing with a modifier of the complementive is also clear from the fact that the clause cannot occur adjacent to it if there is a verb in clause-final position; restrictive and non-restrictive relative clauses are normally possible in preverbal position. The number sign indicates that examples like (282b) cannot be interpreted as an identity statement, although it can be used to refer to a certain friend who also happens to be a thief.

- (282) a. dat het je VRIEND is [die t<sub>i</sub> het boek gestolen heeft].  
 that it your friend is who the book stolen has  
 'that it is your friend who has stolen the book.'
- b. #dat het je VRIEND [die t<sub>i</sub> het boek gestolen heeft] is.  
 that it your friend who the book stolen has is  
 'that it is your friend who has stolen the book.'

In the linguistic literature on Dutch, cleft constructions have received little attention, which may be related to the fact that some researchers consider it a

barbarism, which replaces the more regular construction that uses accent only, as in *Je VRIENDJE heeft het boek gestolen* ‘Your friend has stolen the book’; see Paardekooper (1986:901), who seems to think that French influence plays a role here. Paardekooper analyzes the clause as an extraposed subject introduced by the anticipatory pronoun *het*. The reason is that it can also be preposed, as in (283a), which results in a construction that closely resembles the English pseudo-cleft construction. The fact that (283a) is more or less equivalent to (283b) further suggests that the clause is a free relative, and this is indeed what is suggested by Paardekooper as well as Smits (1989:section 4.2).

- (283) a. [Die het boek gestolen heeft] is je VRIEND.  
 who the book stolen has is your friend  
 ‘Who has stolen the book is your friend.’
- b. Degeen [die het boek gestolen heeft] is je VRIEND.  
 the-person who the book stolen has is your friend  
 ‘The person who has stolen the book is your friend.’

De Vries (2002) voices some scepticism about claims that constructions of the type above should be identified with English cleft and pseudo-cleft constructions because the Dutch constructions have hardly been studied in their own right so far and it is not clear whether the findings for English carry over to Dutch. Since a detailed discussion will have to await until future research has clarified this issue, we confine ourselves here to noting that the movement of the relative-like element *die* into clause-initial position exhibits the hallmarks of *wh*-movement: the examples in (284), for instance, show that it is not clause-bound but nevertheless island-sensitive in that it cannot be extracted from an embedded question or an adjunct clause.

- (284) a. Het is je VRIEND [die ik denk [dat  $t_i$  het boek gestolen heeft]].  
 it is your friend who I think that the book stolen has  
 ‘that it is your friend who I think has stolen the book.’
- b. \*Het is je VRIEND [die ik me afvraag [of  $t_i$  het boek gestolen heeft]].  
 it is your friend who I REFL wonder if the book stolen has
- c. \*Het is je VRIEND [die ik huil [omdat  $t_i$  mijn boek gestolen heeft]].  
 it is your friend who I cry because my book stolen has

### 11.3.3. Topicalization

This section discusses topicalization, the phenomenon that in main clauses virtually any clausal constituent (and sometimes also parts thereof) may precede the finite verb in second position. Subsection I starts by showing that, as in the case of question formation, the moved constituent can have a wide range of syntactic functions and can be of any category. Subsection II continues by comparing topicalization to question formation (as well as relativization) in order to motivate the claim that it is derived by *wh*-movement; we will see that, apart from the fact that topicalization is a root phenomenon, there are indeed compelling reasons for assuming *wh*-movement to be involved in the derivation. Subsection III repeats some arguments from Section 9.3 for rejecting the traditional view that subject-initial sentences are necessarily derived by topicalization; exclusion of such



sentences from the set of topicalization constructions will lead to the conclusion that such constructions have two characteristic properties: they exhibit subject-verb inversion and have a non-neutral reading. Subsection IV explores the latter issue, and will show that topicalized phrases often play a special role in discourse; they express a contrastive °focus, act as a topic, or perform a special function in the organization of the discourse. Given this, we may expect for contrastively focused phrases and topics at least that *wh*-movement may pied-pipe a larger phrase if syntactic restrictions prohibits extraction and subsection V shows that this expectation is indeed borne out. Subsection VI continues with a discussion of topicalization of clauses and smaller verbal projections: such cases are special because *wh*-movement of such constituents is not possible in the case of question formation and relativization. Subsection VII concludes with a comparison of topicalization in Dutch and English, and will show that there are a number of conspicuous differences, which raises the question as to whether the two should be considered phenomena of the same kind.

*I. Syntactic function and categorial status of the topicalized element*

The traditional generative analysis holds that main clauses are derived by placing the finite verb in the second position of the clauses, the so-called C-position in (285), followed by topicalization of some constituent into the so-called clause-initial position, the specifier of CP; see Section 11.1 for details.

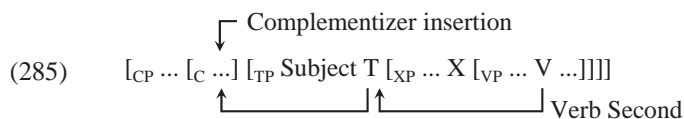

There seem to be virtually no restrictions on the syntactic function or the categorial status of the topicalized element. The examples in (286) start by showing this for nominal arguments: subjects, direct and indirect objects are all possible in sentence-initial position.

- (286)
- Nominal arguments
  - a. Marie/Ze heeft haar broer/hem die baan aangeboden. [subject]  
 Marie/she has her brother/him that job prt.-offered  
 ‘Marie/She has offered her brother/him that job.’
  - b. DIE BAAN heeft ze her brother/him aangeboden. [direct object]  
 that job has she her brother/him prt.-offered  
 ‘That job, she has offered [to] her brother/him.’
  - c. Haar BROER/HEM heeft ze die baan aangeboden. [indirect object]  
 her brother/him has she that job prt.-offered  
 ‘Her brother/Him, she has offered that job.’

There are, however, two important differences between subject-initial sentences and sentences with an object in first position. First, clause-initial objects can be considered to be semantically marked in that they act as discourse topics or contrastive foci, or have some other special function in the organization of the discourse, while this does not necessarily hold for clause-initial subjects. Second,

topicalized objects are often characterized by a special intonation pattern: the objects in (286b&c), but not the clause-initial subjects in (286a), must be accented, as is clear from the fact the latter but not the former can be a reduced pronoun. This suggests that subject-initial sentences may also be syntactically different from constructions with topicalized objects; we will return to this issue in Subsection III.

Next, the examples in (287) show that it is also possible to topicalize prepositional objects: (287a) illustrates this for a prepositional indirect object and (287b) for the prepositional object of *kijken* (*naar*) ‘to look (at)’.

- (287) • Prepositional arguments
- a. Aan haar BROER/HEM heeft ze die baan aangeboden. [indirect object]  
to her brother/him has she that job prt.-offered  
‘His her brother/him, she has offered that job to.’
  - b. Naar dat HUIS staat Jan al een uur te kijken. [prepositional object]  
at that house stands Jan already an hour to look  
‘That house, Jan has been staring at for an hour.’

Complementives can also be topicalized: we illustrate this in (288) by means of three examples with complementives of a different categorial status; they show that noun phrases, APs and PPs can all be topicalized.

- (288) • Complementive
- a. Een LIEFHEBBER van Jazz ben ik niet echt. [nominal]  
a devotee of jazz am I not really  
‘A devotee of jazz, I am not really.’
  - b. AARDIG is de nieuwe directeur beslist. [adjectival]  
nice is the new director definitely  
‘Nice, the new director definitely is.’
  - c. In de LA heb ik de schaar gelegd. [adpositional]  
into the drawer have I the scissors put  
‘In the drawer, I have put the scissors.’

Adjuncts can also be topicalized. Example (289a) shows this for °supplementives and examples (289b&c) for adverbial phrases. Observe that we did not mark the adverbial phrases for accent; assigning accent is possible but does not seem to be necessary. We will return to this issue in Subsection IV.

- (289) • Adjuncts
- a. KWAAD liep hij weg. [supplementive]  
angry walked he away  
‘Angry, he walked away.’
  - b. Op zolder slapen de kinderen. [place adverbial]  
on attic sleep the children  
‘In the attic, the children sleep/are sleeping.’
  - c. Na de vergadering vertrekken we. [time adverbial]  
after the meeting leave we  
‘After the meeting, we will leave.’

The discussion above has shown that topicalization is like *wh*-question formation in that constituents with various syntactic functions (argument, complementive and adjunct) and of various different forms (noun phrase, AP and PP) can be moved into sentential-initial position. Topicalization differs from *wh*-movement, however, in that it also allows preposing of clauses; this is illustrated in (290) for a finite clause. We return to topicalization of clauses in Subsection VI. Accent can be assigned at various places within the preposed clause.

- (290) • Clauses
- a. Ik verwacht niet [dat hij dat boek wil hebben].  
I expect not that he that book wants have  
'I don't expect that he wants to have that book.'
  - b. [Dat hij dat boek wil hebben] verwacht ik niet.

The examples in (291) show that it is also possible to topicalize the complement of perfect and passive auxiliaries, a phenomenon known as VP-topicalization. The (a)-examples show that topicalization of the participle is possible both with and without the direct object; the (b)-examples show that subjects are normally not affected. VP-topicalization will also be discussed in Subsection VI. Accent will normally be assigned to the object if it is pied piped by VP-topicalization.

- (291) • VP-topicalization
- a. Ze hebben mijn huis nog niet geschilderd. [perfect]  
they have my house yet not painted  
'They haven't painted my house yet.'
  - a'. [<Mijn huis> geschilderd] hebben ze <mijn huis> nog niet.
  - b. Mijn huis wordt volgend jaar geschilderd. [passive]  
my house be next year painted  
'My house will be painted next year.'
  - b'. Geschilderd wordt mijn huis volgend jaar.

## II. Topicalization is a subcase of *wh*-movement

Topicalization involves movement of some constituent into the initial position of the main clause. It resembles the formation of *wh*-questions in that the movement targets the position immediately preceding the finite verb; this is illustrated again in the (b)-examples in (292). This observation is not trivial; this does not hold for a language like English. We return to this in Subsection VII.

- (292) a. Jan heeft gisteren dat boek gelezen.  
Jan has yesterday that book read  
'Jan read that book yesterday.'
- b. Welk boek<sub>i</sub> heeft Jan gisteren t<sub>i</sub> gelezen? [wh-question]  
which book has Jan yesterday read  
'Which book did Jan read yesterday?'
  - b'. Dat boek<sub>i</sub> heeft Jan gisteren t<sub>i</sub> gelezen. [topicalization]  
that book has Jan yesterday read  
'That book, Jan read yesterday.'

The (b)-examples in (293) show that topicalization differs from question formation (and relativization) in that it is a root phenomenon. It cannot apply in embedded clauses.

- (293) a. Marie zei [dat Jan dat boek gelezen heeft].  
 Marie said that Jan that book read has  
 ‘Marie said that Jan has read that book.’
- b. Marie vroeg [welk boek<sub>i</sub> Jan t<sub>i</sub> gelezen heeft]. [wh-question]  
 Marie asked which book Jan read has  
 ‘Marie asked which book Jan has read.’
- b'. \*Marie zei [dat boek<sub>i</sub> Jan t<sub>i</sub> gelezen heeft]. [topicalization]  
 Marie said that book Jan read has

There is no way in which embedded topicalization in examples such as (293b') can be improved. The examples in (294), for instance, show that Dutch does not have the option found in German to have topicalization in embedded clauses with verb-second, as embedded verb-second is categorically prohibited in Dutch. We refer the reader to Haider (1985/2010) and Barbiers (2005: Section 1.3.1.8) for a discussion of embedded verb-second in, respectively, German and a number of non-standard varieties of Dutch; the German example in (294a) is taken from Müller (1998:42) in a slightly adapted form.

- (294) a. Marie sagte [dieses Buch<sub>i</sub> habe<sub>conjunctive</sub> sie t<sub>i</sub> bereits gelesen]. [German]  
 Marie said this book has she already read  
 ‘Marie said that this book, she had already read.’
- b. \*Marie zei [dit boek<sub>i</sub> had ze t<sub>i</sub> al gelezen]. [Dutch]  
 Marie said this book had she already read

The examples in (294) also show that embedded topicalization cannot occur with a phonetically expressed complementizer, unlike what is the case in English examples such as (295a); cf., e.g., Chomsky (1977), Baltin (1982) and Lasnik & Saito (1992). Since there is no *a priori* reason to think that Dutch topicalization targets a different position than English topicalization, we have added example (295b'), in which the complementizer *dat* ‘that’ precedes the topicalized phrase.

- (295) a. Marie thinks [that this book<sub>i</sub> you should read t<sub>i</sub>]. [English]
- b. \*Marie denkt [dit boek<sub>i</sub> dat je zou t<sub>i</sub> moeten lezen]. [Dutch]  
 Marie thinks this book that you would must read
- b'. \*Marie denkt [dat dit boek<sub>i</sub> je t<sub>i</sub> zou moeten lezen]. [Dutch]  
 Marie thinks that this book you would must read

Examples (296a&b) show that topicalization is like question formation in that it allows long *wh*-movement if a bridge verb such as *denken* ‘to think’ is present. It should be noted, however, that long topicalization is like relativization in that it is possible with a wider range of verbs than question formation; cf. Schippers (2012:105). For instance, the factive verb *weten* ‘to know’ permits long topicalization (and long relativization), but not long *wh*-movement. It should further be noted that some speakers prefer the resumptive prolepsis construction in (296c) to the somewhat marked long topicalization construction in (296b).

- (296) a. Welk boek<sub>i</sub> denk/\*weet je [dat Jan *t*<sub>i</sub> gekocht heeft]? [wh-question]  
 which book think/know you that Jan bought has  
 ‘Which book do you think that Jan has bought?’
- b. <sup>(2)</sup>Dit boek<sub>i</sub> denk/weet ik [dat Jan *t*<sub>i</sub> gekocht heeft]. [topicalization]  
 this book think.know I that Jan bought has  
 ‘This book I think/know that Jan has bought.’
- c. Van dit boek<sub>i</sub> denk/weet ik [dat Jan het<sub>i</sub> gekocht heeft]. [prolepsis]  
 of this book think/know I that Jan it bought has  
 ‘As for this book, I think/know that Jan has bought it.’

That topicalization involves *wh*-movement is also suggested by the fact that it is island-sensitive, just like question formation and relativization. We illustrate this in (297b) by means of an embedded polar question. For completeness’ sake, we have added (297b’) to show that the intended meaning can be expressed by means of a resumptive prolepsis construction.

- (297) a. Ik vraag me af [of Jan dat boek gekocht heeft]?  
 I wonder REFL prt. if Jan that book bought has  
 ‘I wonder whether Jan has bought that book.’
- b. \*Dat boek<sub>i</sub> vraag ik me af [of Jan *t*<sub>i</sub> gekocht heeft]?  
 that book wonder I REFL prt. if Jan bought has
- b’. Van dat boek<sub>i</sub> vraag ik me af [of Jan het<sub>i</sub> gekocht heeft]?  
 of that book wonder I REFL prt. if Jan it bought has  
 ‘As for this book, I am wondering whether Jan has bought it.’

Example (298b) illustrates the island-sensitivity of topicalization by means of an adjunct island. In this case, the resumptive prolepsis construction is not available as an alternative because the verb *huiden* ‘to cry’ does not license a resumptive *van*-PP.

- (298) a. Jan huilt [omdat Marie dat boek gestolen heeft].  
 Jan cries because Marie that book stolen has  
 ‘Jan is crying because Marie has stolen that book.’
- b. \*Dat boek<sub>i</sub> huilt Jan [omdat Marie *t*<sub>i</sub> gestolen heeft].  
 that book cries Jan because Marie stolen has

This subsection has shown that topicalization exhibits various hallmarks of *wh*-movement: it targets the clause-initial position, it can be extracted from clauses selected by bridge verbs and it is island-sensitive. What sets it apart from *wh*-movement and relativization is that it is a root phenomenon; it cannot target the initial position of embedded clauses. We refer to Hoekstra & Zwart (1994), Sturm (1996) and Zwart & Hoekstra (1997) for a discussion of the question as to whether this shows that topicalization targets a different position than *wh*-movement, as in fact would be claimed in the cartographic approach initiated by Rizzi (1997).

### III. Subject-initial clauses versus topicalization constructions

The standard view in generative grammar is that topicalization is responsible for verb second in declarative main clauses in Dutch. The verb is first moved into the C-position immediately preceding the canonical subject position, after which the specifier position of CP is filled by some topicalized phrase. This implies that

subject-initial main clauses such as (299a) must be derived by topicalization, as indicated in the representation in (299b).

- (299) a. Mijn zuster/Zij/Ze heeft dit boek gelezen. [subject]  
 my sister/she/she has this book read  
 ‘My sister/she has read this book.’

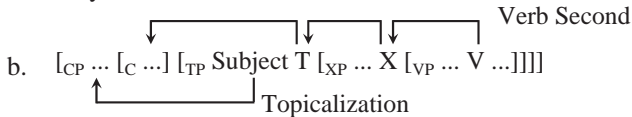

If the derivation in (299) is correct, we would expect the placement of subjects to be subject to similar restrictions as other cases of topicalization, like in the examples in (300). We seen in Subsection I, however, that subjects crucially differ from objects in that they need not be accented. The effect is even more conspicuous with weak (phonetically reduced) pronouns; while (299a) shows that the weak subject pronoun *ze* ‘she’ is fully acceptable in sentence-initial position, weak object pronouns like *’r* ‘her’ in (300a&b) are not because they cannot be accented; see, e.g., Bouma (2008:34) for more discussion. Adverbial PPs with a weak pronominal complement can be topicalized if the preposition can be assigned accent; see Salverda (2000).

- (300) a. Mijn ZUSTER/HAAR/\*’r heb ik nog niet gezien. [direct object]  
 my sister/her/her have I yet not seen  
 ‘My sister/her I haven’t seen yet.’
- b. Op mijn ZUSTER/HAAR/\*’r wil ik niet wachten. [PP-object]  
 for my sister/her/her want I not wait  
 ‘My sister/Her I don’t want to wait for.’
- c. NAAST ’r zat een aardige heer.  
 next.to her sat a kind gentleman  
 ‘Next to her sat a kind gentleman.’

The same contrast is found with the weak R-word *er*: the examples in (301) show that expletive *er*, which is normally assumed to occupy the regular subject position, can easily occur in sentence-initial position, but that this is excluded for *er* functioning as a locative pro-form or the pronominal part of a PP; topicalization is only possible with strong forms like *daar* ‘there’ and *hier* ‘here’; see, e.g., Bouma (2008:29-30). We will ignore here that things are slightly complicated by the fact that (sentence-initial) *er* may sometimes have more than one function; we refer the reader to Section P5.5.3 for discussion and examples.

- (301) a. Er spelen veel kinderen op straat. [expletive *er*]  
 there play many children on street  
 ‘There are many children playing in the street.’
- b. Daar/\*Er spelen de kinderen graag. [locative *er*]  
 there/there play the children gladly  
 ‘The children like to play there.’
- c. Daar<sub>i</sub>/\*Er<sub>i</sub> wacht ik niet [ *t<sub>i</sub>* op]. [pronominal part of PP]  
 there/there wait I not for  
 ‘That I won’t wait for.’

That this contrast should have an impact on our syntactic analysis is clear from the fact illustrated in (302) that subject pronouns do exhibit a similar behavior as object pronouns if they are extracted from an embedded clause: whereas noun phrases like *mijn zuster* ‘my sister’ and strong (phonetically non-reduced) subject pronouns such as *zij* give rise to a reasonably acceptable result, topicalization is excluded if the subject pronoun is weak.

- (302) a. <sup>(?)</sup>Mijn ZUSTER<sub>i</sub>/ZIJ<sub>i</sub> zei Jan [dat *t<sub>i</sub>* dit boek gelezen had].  
 my sister/she said Jan COMP this book read had  
 ‘My sister/she, Jan said had read the book.’  
 b. \*Ze<sub>i</sub> zei Jan [dat *t<sub>i</sub>* dit boek gelezen had].  
 she said Jan COMP this book read had

Section 9.3 concluded from this that regular subject-initial constructions do not involve topicalization but are derived by simply placing the subject in the regular subject position, the specifier of the T(ense) head. This resulted in the following derivations of subject-initial clauses and topicalization constructions; cf. Travis (1984) and Zwart (1992/1997). Note that these analyses suggest that subject-verb inversion is a hallmark of topicalization constructions; cf. Salverda (1982/2000).

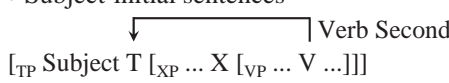
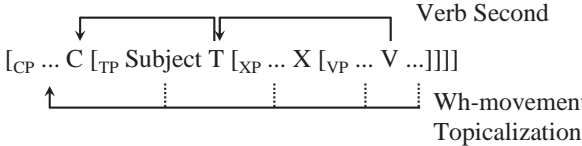
- (303) a. • Subject-initial sentences  

  
 b. • Topicalization constructions  

Observe that we are not claiming here that subjects cannot be topicalized, but only that they are not topicalized if they occur in a neutrally pronounced sentence. Examples like (304a) with contrastive accent on the subject may involve topicalization. That they do so is strongly suggested by expletive constructions like (304b); since it is normally assumed that the expletive *er* ‘there’ occupies the regular subject position, the subject *niemand* can only occur in sentence-initial position as a result of topicalization. We added the locational adverbial phrase *op de vergadering* to example (304b) to block a locative interpretation of *er* ‘there’ in order to ensure that *er* indeed functions as an expletive.

- (304) a. Mijn ZUSTER heeft dit boek gelezen.  
 my sister has this book read  
 ‘My sister/she has read this book.’  
 b. NIEMAND was er op de vergadering.  
 nobody was there at the meeting  
 ‘Nobody was there at the meeting.’

The analyses suggested in (303) are interesting in view of the fact that subject-initial clauses are the most neutral form of an utterance from a semantic view point: while



topicalized phrases are special in that they play a specific role in structuring the discourse, sentence-initial subjects are often neutral in this respect. The representations in (303) thus enable us to express formally this by postulating that like question formation and relativization, topicalization is semantically motivated; see Dik (1978: Section 8.3.3), Haegeman (1995), Rizzi (1997), and many others. This will be the main topic of Subsection IV.

#### *IV. Information structure: focus and topic*

The information structure of a clause is closely related to its intonation pattern. In utterances like the (b)-examples in (305), which present new information only if intended as an answer to the question in (305a), the main accent is located at the end of the clause, normally on the constituent preceding the clause-final verbs; see Section 13.1, sub III, for a more detailed discussion. We will refer to utterances with this intonation pattern as neutral clauses (in order to not complicate things we will discuss main clauses only).

- (305) a. Wat is er gebeurd?  
 what is there happened  
 ‘What has happened?’
- b. Jan heeft Marie een BRIEF gestuurd.  
 Jan has Marie a letter sent  
 ‘Jan has sent Marie a letter.’
- b’. Jan heeft een brief naar MARIE gestuurd.  
 Jan has a letter to Marie sent  
 ‘Jan has sent a letter to Marie.’

The intonation pattern of utterances can be affected by the information structure of the clause. In the primed examples in (306), which contain both presupposed and new information if used as answers to the questions in the primeless examples, the main accent must be located in the new information of the clause (henceforth: the new-information °focus); in the cases at hand, this results in the placement of the main accent in a more leftward position. For more information about assignment of main accent in clauses we refer the reader to Booij (1995).

- (306) a. Wie heeft Jan een brief gestuurd? [question]  
 who has Jan a letter sent  
 ‘Who has Jan sent a letter?’
- a’. Hij heeft MARIE een brief gestuurd. [answer]  
 Jan has Marie a letter sent  
 ‘He has sent Marie a letter.’
- b. Wat heeft Jan naar Marie gestuurd? [question]  
 what has Jan to Marie sent  
 ‘What has Jan sent to Marie?’
- b’. Hij heeft een BRIEF naar Marie gestuurd. [answer]  
 Jan has a letter to Marie sent  
 ‘Jan has sent a letter to Marie.’

The following subsections will show that topicalization may also affect the intonation pattern of utterances; we will see that the way in which the intonation pattern is affected depends on the impact topicalization has on the information structure of the clause. There are also a number of cases in which topicalization does not seem to have such a great impact on the intonation of the clause; we will discuss some of the prototypical cases. Before we start, we want to note that the literature exhibits a great deal of variation when it comes to information-structural notions like focus and topic; cf. Erteschik-Shir (2007) for an extensive review. We aim at staying close to the use of these notions in É. Kiss' (2002:ch.1-6) description of the Hungarian clause, in which these notions play a prominent role.

A. *Contrastive/restrictive focus*

The NEW-INFORMATION focus can also be placed in sentence-initial position as a result of topicalization. So, next to the answers in the primed examples in (306), we also find utterances like (307a&b). The parentheses indicate that the presuppositional part of such answers is normally omitted.

- (307) a. MARIE (heeft hij een brief gestuurd). [answer to (306a)]  
 Marie has he a letter sent  
 'Marie, he has sent a letter.'
- b. Een BRIEF (heeft hij naar Marie gestuurd). [answer to (306b)]  
 a letter has he to Marie sent  
 'A letter, he has sent to Marie.'

Jansen (1981: Section 4.2.1) claims that focus topicalization of the type in (307) is not very frequent (in non-interrogative contexts), which raises the question as to whether we are simply dealing with new-information focus or whether utterances such as (307) have some *additional* property. We tend to think that the accents in these topicalization constructions are stronger than those in the primed examples in (306), which may suggest that topicalization constructions express CONTRASTIVE or RESTRICTIVE focus in the sense that the proposition holds for the focussed phrases, to the exclusion of any other referent; see Section 13.3.2 for more discussion.

This would be in line with the fact that utterance (307a) expresses that in the relevant domain of discourse only Marie was sent a book by Jan: if it were to turn out that Jan also sent a letter to Peter and that the speaker uttering (307a) was aware of that, he could be accused of not being fully informative by withholding information. The same would hold for utterance (307b) if it turned out that Jan also sent cocaine to Marie.

That we are dealing with restrictive focus is also supported by the fact that it is often impossible to topicalize non-specific indefinite noun phrases, as these are typically used for introducing new information but cannot easily be used in a contrastive or a restrictive fashion. Example (308a') shows, for example, that topicalization of the existential pronoun *iemand* gives rise to a highly marked result, and (308b') shows that topicalization of an indefinite noun phrase such as *een pianist* is restricted to cases in which the speaker contradicts a certain presupposition on the part of the addressee: it would be acceptable as a reaction to

the following question: *Hoe was je ontmoeting met die cellist gisteren?* ‘How was your meeting with that cellist yesterday?’.

- (308) a. Ik heb gisteren IEMAND ontmoet.  
I have yesterday someone met  
‘I met someone yesterday.’  
a'. <sup>??</sup>IEMAND heb ik gisteren ontmoet.  
b. Ik heb gisteren een PIANIST ontmoet.  
I have yesterday a pianist met  
‘I met a pianist yesterday.’  
b'. <sup>#</sup>Een PIANIST heb ik gisteren ontmoet.

The negative pronoun *niemand* ‘nobody’, on the other hand, can be topicalized in constructions such as (309a) if the speaker wants to express that he did expect to see in Amsterdam at least one person from the given domain of discourse. Similarly, example (309b) expresses that the speaker did not expect to be able to meet in Amsterdam all individuals in the given domain of discourse.

- (309) a. NIEMAND heb ik in Amsterdam gezien (zelfs JAN niet).  
nobody have I in Amsterdam seen even Jan not  
‘Nobody, I have seen in Amsterdam (not even Jan).’  
b. IEDEREEN heb ik in Amsterdam kunnen ontmoeten (zelfs MARIE).  
everybody have I in Amsterdam can meet even Marie  
‘Everyone, I have been able to meet in Amsterdam (even Marie).’

Another indication that we are not dealing with mere new-information focus is that the topicalized phrase may be preceded by an (emphatic) focus particle like *zelfs* ‘even’, *alleen* ‘solely’, *slechts/maar* ‘only’: cf. Barbiers (1995:ch.3).

- (310) a. Zelfs MARIE heeft hij een brief gestuurd.  
even Marie has he a letter sent  
‘He has even sent Marie a letter.’  
b. Alleen MARIE heeft hij een brief gestuurd.  
only Marie has he a letter sent  
‘Only Marie he has sent a letter.’  
c. Slechts TWEE studenten haalden het examen.  
only two students passed the exam  
‘Only two students passed the exam.’

For want of more detailed information on the question as to whether topicalized focus phrases indeed necessarily express more than merely new information, we have to leave our suggestions above to future research.

### *B. Aboutness topic*

The sentence-initial position is typically occupied by an ABOUTNESS TOPIC, a phrase referring to an entity about which the sentence as a whole provides more information. Although the three examples in (311) express the same propositions, they provide additional information about completely different topics: in (311a) the topic is the subject *Jan*, in (311b) the topic is the direct object *de brief* ‘the letter’,

and in (311c) the topic is embedded in the °complementive *naar*-PP. Observe that the comments in (311) typically contain new information and thus also contain sentence accent (which is again placed on the constituent preceding the clause-final verbs if the full comment consists of new information).

- (311) a. [<sub>TOPIC</sub> JAN] [<sub>COMMENT</sub> heeft de brief naar MARIE gestuurd].  
 Jan has the letter to Marie sent  
 ‘Jan has sent the letter to Marie.’
- b. [<sub>TOPIC</sub> De BRIEF] [<sub>COMMENT</sub> heeft Jan naar MARIE gestuurd].  
 the letter has Jan to Marie sent  
 ‘The letter, Jan has sent to Marie.’
- c. [<sub>TOPIC</sub> Naar MARIE] [<sub>COMMENT</sub> heeft Jan de BRIEF gestuurd].  
 to Marie has Jan the letter sent  
 ‘To Marie, Jan has sent the letter.’

The new information in (311) is provided by an argument, but the examples in (312) show that this can also be an adverbial element that can be used contrastively, such as the negative adverb *niet*, which can be contrasted with the affirmative marker *wel*, or adverbs such as *morgen* ‘tomorrow’, which can be contrasted with adverbs like *vandaag* ‘today’ or *nu* ‘now’. For more examples, see Salverda (2000:100-1).

- (312) a. PETER heb ik nog NIET gezien.  
 Peter have I not yet seen  
 ‘Peter, I haven’t seen yet.’
- b. Het BOEK moet je MORGEN maar lezen.  
 the book must you tomorrow PRT read  
 ‘The book, you should read tomorrow.’

The aboutness topic is always part of the domain of discourse, which means that it must satisfy certain criteria: (i) it must be referential in the sense that it refers to an entity or set of entities and (ii) it must be specific, that is, the entity or set of entities must be identifiable in the domain of discourse. This implies that the aboutness topic is prototypically a proper noun, a referential personal pronoun, a definite noun phrase, a specific indefinite noun phrase, or a PP containing such a noun phrase; see É. Kiss (2002: chapter 2).

### C. Contrastive topics

CONTRASTIVE TOPICS differ from aboutness topics in that they need not be referential or specific; the examples in (313) show that they can be non-individual-denoting elements like bare plurals, indefinite noun phrases, adverbial phrases and verbal particles; examples such as (313a&b) are of course also possible with definite noun phrases (*de zwaan/zwanen* ‘the swan/swans’) but this is not illustrated here. Contrastive topics are accented and followed by a brief fall in intonation on the following comment, which gives rise to a typical “hat” contour marked by the symbols “/” and “\”. Contrastive topic constructions convey that there is an alternative topic for which an alternative comment holds (cf. É. Kiss 2002: Section

2.7); we made this explicit in the examples in (313) by adding the part within parentheses.

- (313) a. [<sub>TOPIC</sub> /ZWANEN] [<sub>COMMENT</sub> \heb ik NIET gezien] (maar GANZEN WEL).  
 swans have I not seen but geese AFF  
 ‘I haven’t seen swans, but I did see geese.’
- b. [<sub>TOPIC</sub> /Een ZWAAN] [<sub>COMMENT</sub> \heb ik NIET gezien] (maar WEL een GANS).  
 a swan have I not seen but AFF a goose  
 ‘I haven’t seen a swan, but I did see a goose.’
- c. [<sub>TOPIC</sub> /OMHOOG] [<sub>COMMENT</sub> \ga ik met de LIFT] (maar OMLAAG via de TRAP).  
 up go I by the elevator but down via the stairs  
 ‘Up I will use the elevator, but down I will take the stairs.’
- d. [<sub>TOPIC</sub> /TEGEN] [<sub>COMMENT</sub> \stemden de SOCIALISTEN] (VOOR de LIBERALEN).  
 against voted the socialists for the liberals.  
 ‘The conservatives voted against (the bill), the liberals for.’

The intonation pattern found in utterances like (313) is also possible with individual-denoting elements like the topics in (311). Applying the “hat” contour to these examples will result in similar contrastive readings as those in (313). For completeness’ sake, note that examples such (313d) refute the persistent claim that verbal particles cannot be topicalized (cf., e.g., Zwart 2011:72); this is possible provided that they stand in opposition to another verbal particle (cf. Hoeksema 1991a) and thus allow a contrastive interpretation. We refer the reader to Section 13.3.2, sub II, for a more detailed discussion of contrastive topics.

#### D. Topic shift

The distal demonstrative pronouns *die* ‘that’ and *dat* ‘that’ are very common in sentence-initial position. These pronouns are used to refer to some referent in the immediately preceding context, as in example (314). We added indices in order to unambiguously indicate the intended interpretation of the pronoun. Topicalized demonstratives differ from the topicalized phrases discussed so far in that they need not have contrastive accent; see, e.g., Salverda (1982/2000) and Bouma (2008:45).

- (314) a. Heb je Jan<sub>i</sub> gezien? Nee, die<sub>i</sub> is ziek.  
 have you Jan seen no DEM is ill  
 ‘Did you see Jan? No, he is ill.’

The demonstrative can be accented, in which case it receives a contrastive/restrictive focus interpretation. If it remains unstressed, it typically indicates topic shift, that is, a change of aboutness topic. In this respect distal demonstratives differ crucially from referential personal pronouns like *hij* ‘he’ or *zij* ‘she’, which typically refer to continuous topics. This is illustrated by means of the examples in (315); that the distal demonstrative brings about topic shift is clear from the fact that it cannot refer to the subject (the default topic) of the preceding sentence; referential pronouns are not subject to this restriction. We will not digress on topic shift here but refer the reader to Section N5.2.3.2.2, sub IA, for a more extensive discussion.

- (315) a. [Jan<sub>i</sub> ontmoette Els<sub>j</sub>] en [hij<sub>i</sub>/\*die<sub>i</sub> vertelde haar<sub>j</sub> dat ... ]  
 Jan met Els and he/DEM told her that  
 b. [Jan<sub>i</sub> ontmoette Els<sub>j</sub>] en [ze<sub>j</sub>/die<sub>j</sub> vertelde hem<sub>i</sub> dat ... ]  
 Jan met Els and she/DEM told him that

Note further that distal demonstrative pro-forms like *die* ‘that’ and *dat* ‘that’ in sentence-initial position are often omitted in speech; we refer the reader to Section 11.2.2 for discussion of this.

### E. Connectives

The previous subsection has shown that unstressed demonstratives can be used to indicate a topic shift and are thus quite important for a smooth continuation of the discourse. Other topicalized elements with a similar function are connectives like *daarom/dus* ‘therefore’, and *desondanks* ‘nevertheless’, which are neither topical nor focal in nature but are simply used to indicate the relation between two successive sentences; cf. Salverda (1982).

- (316) a. [Marie is ziek] en [daarom kan ik niet komen].  
 Marie is ill and therefore can I not come  
 ‘Marie is ill and therefore I cannot come.’  
 b. [Marie is ziek] maar [desondanks zal ik komen].  
 Marie is ill but nevertheless will I come  
 ‘Marie is ill but nevertheless I will come.’

### F. Formal movement: movement without semantic effect

The cases of topicalization discussed in the previous subsections are all functionally motivated by information-structural considerations or considerations related to the organization of discourse. There are, however, many cases in which it is not so clear what the functional motivation of topicalization would be. Consider the examples in (317): it has been claimed that the locational PP in (317a) must be interpreted contrastively and thus be assigned accent, whereas the locational PP in (317b) can be interpreted neutrally and thus be pronounced without any phonetic prominence.

- (317) a. In UTRECHT heeft Marie haar broer bezocht.  
 in Utrecht has Marie her brother visited  
 ‘In Utrecht Marie has visited het brother.’  
 b. In Utrecht is Els erg populair.  
 in Utrecht is Els very popular  
 ‘In Utrecht, Els is still very popular.’

This contrast between the two examples has been related to the semantic contribution of the PPs. The PP in (317a) is event-related in the sense that it is part of what is asserted: Marie has met Jan & this eventuality took place in Utrecht. This reading has the property that omission of the locational PP is possible without affecting the truth value of the assertion. The PP in (317b), on the other hand, is not event-related but is used to restrict the speaker’s claim; this reading has the property that omission of the locational PP may affect the truth value of the assertion: from the fact that Els is popular in Utrecht we cannot infer that she is popular elsewhere.

The contrast between the two examples in (318) shows that the difference between the two readings is associated with a difference in location of the PP in the middle field of the clause: while the PP can easily precede the subject in (318b), this gives rise to a marked result in (318a) (although the latter example improves if the subject is assigned contrastive accent). We refer to Maienborn (2001) for a more detailed discussion.

- (318) a. dat <??in Utrecht> Marie <in Utrecht> haar broer bezocht heeft.  
 that in Utrecht Marie her brother visited has  
 ‘that Marie has visited her brother in Utrecht.’  
 b. dat <in Utrecht> Els <in Utrecht> erg populair is.  
 that in Utrecht Els very popular is  
 ‘that in Utrecht Els is still very popular.’

There is a wide range of (especially) adverbial phrases that are not directly event-related, and which may occur in sentence-initial positions with no or little emphasis; see Kooij (1978), Salverda (1982/2000) and Florijn (1992). These include at least certain restrictive temporal, modal, and speaker-related adverbials.

- (319) a. In de middeleeuwen waren heksen heel gewoon. [restrictive temporal]  
 in the middle ages were witches very common  
 ‘In the Middle Ages, witches were very common.’  
 b. Misschien komt Peter straks nog. [modal]  
 maybe comes Peter later PRT  
 ‘Maybe Peter will come later.’  
 c. Helaas kan Peter niet komen. [speaker-related]  
 unfortunately can Peter not come  
 ‘Unfortunately, Peter cannot come.’

Examples of the type in (317b) and (319) are sometimes accounted for by introducing special mechanisms. Odijk (1995:section 2.1), for instance, proposes that adverbials like *misschien* ‘maybe’ and *helaas* ‘unfortunately’ can be base-generated in sentence-initial position. Alternatively, Frey (2006) claims in his discussion of similar German examples that all elements that may (optionally) precede the subject can be moved into the sentence-initial position simply in order to satisfy the V2-requirement; topicalization of such elements is thus predicted not to have any effect on the information structure of the clause. Frey claims that this is confirmed by the fact that dative objects can be topicalized without any special effect in passive and unaccusative constructions; the topicalized phrase in the primed examples in (320) should be able to receive a neutral interpretation in terms of information structure and should not require any special phonetic prominence.

- (320) a. dat Peter/hem/’m gisteren een gratis maaltijd werd aangeboden.  
 that Peter/him/’m yesterday a free meal was prt-offered  
 ‘that a free meal was offered to Peter/him yesterday.’  
 a’. Peter/Hem/\*’m werd gisteren een gratis maaltijd aangeboden.  
 Peter/him/’m was yesterday a free meal prt.-offered  
 ‘A free meal was offered to Peter/him yesterday.’



- b. dat Peter/hem/'m die voorstelling goed bevallen is.  
 that Peter/him/him that show well pleased is  
 'that that show has pleased Peter/him a lot.'
- b'. Peter/Hem/\*'m is die voorstelling goed bevallen.  
 Peter/him/him is that show well pleased  
 'That show has pleased Peter/him a lot.'

Although it does seem to be the case that the topicalized dative objects do not need any special emphasis, the primed examples nevertheless show that they differ from sentence-initial subjects in that they are not able to take the form of the weak pronoun 'm 'him' (see also Bouma 2008:26); this may be incompatible with Frey's claim. Because the judgments on the contrast between the two examples in (317) are subtle anyway, we have to leave it to future research to further investigate whether formal movement in the sense of Frey really exists; it might be interesting, for example, to see whether Frey's claim that the presumed cases of formal movement do not involve any form of prosodic prominence can be confirmed by an in-depth phonetic investigation.

#### V. *Pied piping and stranding*

Subsection IV has shown that topicalization is often semantically motivated. If we restrict ourselves to those forms of topicalization related to information-structure, we can say that topicalization may be used to create a focus-background, a topic-comment, or a topic-focus structure. As in the case of *wh*-question, we would expect that it would suffice to topicalize the focus/topic element, and this raises the question as to whether topicalization may trigger pied piping. It seems that we have to answer this question in the affirmative. Consider the question answer-pair in (321). We have seen that questions like (321a) involve pied piping: while movement of the interrogative pronoun *wiens* 'whose' would in principle suffice to form the desired operator-variable chain, syntactic restrictions force movement of the complete noun phrase *wiens boek* 'whose book'. Since the focus in the answer in (321b) corresponds to the *wh*-pronoun *wiens* we can immediately conclude that topicalization of a focus may trigger pied piping.

- (321) a. [Wiens boek]<sub>i</sub> heb je *t<sub>i</sub>* gekocht?  
 whose book have you bought  
 'Whose book have you bought?'
- b. [JANS boek]<sub>i</sub> heb ik *t<sub>i</sub>* gekocht  
 Jan's book have I bought  
 'Jan's book, I have bought.'

The same can be illustrated by means of the question-answer pair in (322): while *wh*-movement of the nominal complement of the preposition *op* suffices in principle to create the desired operator-variable chain in (322a), the restrictions on preposition stranding in Dutch force movement of the complete PP *op wie* 'for who'. As the focus in answer (322b) corresponds to the *wh*-phrase *wie*, this example again shows that topicalization of a focused phrase may trigger pied piping.

- (322) a. [Op wie]<sub>i</sub> wacht je t<sub>i</sub>?  
 for who wait you  
 ‘Who are you waiting for?’  
 b. [Op JAN]<sub>i</sub> wacht ik t<sub>i</sub>.  
 for Jan wait I  
 ‘Jan, I am waiting for.’

That pied piping depends on independent syntactic constraints can be seen once again by considering the question-answer pair in (323); the question in (323a) shows that stranding of prepositions is possible if the complement is an R-word like *waar*. The fact that the focused constituent *de post* ‘the post’ must pied-pipe the preposition *op* shows that pied piping cannot be semantically motivated.

- (323) a. Waar<sub>i</sub> wacht je [t<sub>i</sub> op]?  
 where wait you  
 ‘What are you waiting for?’  
 b. [Op de POST]<sub>i</sub> wacht ik t<sub>i</sub>.  
 for the post wait I  
 ‘The mail, I am waiting for.’

The examples in (324) illustrate that topicalization of contrastively accented phrases may also trigger pied piping.

- (324) a. [[JANS boek]<sub>i</sub> zal ik t<sub>i</sub> kopen] (maar ELS’ boek niet).  
 Jan’s book will I buy but Els’ book not  
 ‘Jan’s book I will buy, but Els’ book I won’t.’  
 b. [[Op JAN]<sub>i</sub> zal ik t<sub>i</sub> wachten] (maar op ELS niet).  
 for Jan will I wait but for Els not  
 ‘Jan I will wait for, but I won’t for Els.’  
 c. Mijn moeder is 115 jaar, maar [ZO oud<sub>i</sub> [word ik echt niet t<sub>i</sub>]].  
 my mother is 115 year but that old become I really not  
 ‘My mother is 115 years old, but that old I really won’t become.’

Although it is known that stranding and pied piping are relevant notions in the domain of topicalization (cf. Van Riemsdijk 1978), the literature normally focuses on *wh*-movement and relativization, because these allow us to investigate these phenomena without having to appeal to discourse; to our knowledge there is no detailed investigation of pied piping in topicalization contexts that takes information-structural considerations into account. We tend to think that there are not a great many differences vis-à-vis question formation and relativization but this should be confirmed by a more careful investigation than we are able to conduct here.

#### *VI. Topicalization of verbal projections*

Topicalization differs from question formation and relativization in that it allows *wh*-movement of certain types of clauses and other verbal projections. This difference is due to the fact that question formation and relativization normally affect some pronoun or other pro-form while topicalization affects full focus/topic phrases. This means that in the case of question formation and relativization the

only way to get a clause in clause-initial position would be by pied piping, but this is prohibited across-the-board: *wh*-movement of a (part of a) clausal constituent is not able to pied-pipe the containing clause.

- (325) a. *Wat zei hij?* Dat hij Peter niet gelooft. [question formation]  
 what said he that he Peter not believes  
 ‘What did he say? That he doesn’t believe Peter.’
- b. De opmerking [*die me hindert*] is dat hij Peter niet gelooft. [relativization]  
 the remark that me bothers is that he Peter not believes  
 ‘The remark that bothers me is that he doesn’t believe Peter.’
- c. [<sub>Focus/Topic</sub> Dat hij Peter niet gelooft] hindert me. [topicalization]  
 that he Peter not believes annoys me  
 ‘That he doesn’t believe Peter annoys me.’

It is often claimed that constructions with a topicalized verbal projection (and argument clauses in particular) should be analyzed as °left-dislocation constructions with a deleted (phonetically empty) resumptive pronoun; see Koster (1978) and Odiijk (1998) for, respectively, a fairly early and a fairly recent discussion of this issue. This subsection will also consider whether the topicalization constructions discussed in this subsection have a corresponding left-dislocation construction in order to see whether this claim can be maintained. Subsection A starts by discussing topicalization of (finite and infinitival) argument clauses, which is followed in Subsection B by a discussion of topicalization of adverbial clauses. Subsection C addresses VP-topicalization, that is, topicalization of verbal complements of non-main verbs. Subsection D summarizes some of the main findings and draws some general conclusions.

### A. Argument clauses

Chapter 5 has shown that there are various syntactic types of argument clauses. The main division is that between finite and non-finite clauses, and the latter can be subdivided further into *om* + *te*-infinitival, *te*-infinitival and bare infinitival clauses. We discuss these (sub)types in the following subsections.

#### 1. Finite clauses

The singly-primed examples in (326) show that finite subject and direct object clauses can readily be topicalized, and the doubly-primed examples show that such clauses may also appear in left-dislocated position, followed by the resumptive pronoun *dat* ‘that’ in clause-initial position. These examples thus seem to support the hypothesis that topicalization constructions are left-dislocation constructions with a phonetically empty resumptive element. An additional argument in favor of this hypothesis is that the anticipatory pronoun *het* ‘it’ in the primeless examples cannot be used in the singly-primed topicalization constructions. This would follow immediately if these constructions indeed contained a phonetically empty resumptive subject/object pronoun: the anticipatory pronoun *het* could then simply not appear for the same reason that it cannot appear in the doubly-primed examples—it cannot be assigned an independent syntactic function.

- (326) a. Het hindert me [dat hij Peter niet gelooft]. [subject]  
 it annoys me that he Peter not believes  
 'It annoys me that he doesn't believe Peter.'  
 a'. [Dat hij Peter niet gelooft] hindert (\*het) me.  
 a''. [Dat hij Peter niet gelooft], dat hindert me.  
 b. Hij betwistte (het) [dat hij te laat was]. [direct object]  
 he disputed it that he too late was  
 'He disputed (it) that he was late.'  
 b'. [Dat hij te laat was] betwistte hij (\*het).  
 b''. [Dat hij te laat was], dat betwistte hij.

Things are different in the case of verbs selecting a prepositional object. Even verbs that do not require an anticipatory pronominal PP to be present do not allow topicalization of the clause. Left dislocation, on the other hand, is fully acceptable.

- (327) a. Jan twijfelde (erover) [of hij het boek zou kopen]. [PP-complement]  
 Jan doubted about.it if he the book would buy  
 'Jan doubted (about it) whether he would buy the book.'  
 b. \*[Of hij het boek zou kopen] twijfelde Jan (erover).  
 c. [Of hij het boek zou kopen], daar twijfelde Jan over.

Example (328) shows that omission of the pronominal part of the discontinuous PP *daar ... over* in example (327b) also gives rise to an unacceptable result for most speakers (although some speakers seem to accept it at a pinch). The impossibility of omitting *daar* poses a problem for the hypothesis that the topicalization constructions above are left-dislocation constructions with a phonetically empty resumptive element, and requires the introduction of some auxiliary hypothesis to regulate the deletion of resumptive pronouns.

- (328) % [Of hij het boek zou kopen] twijfelde Jan over.  
 whether he the book would buy doubted Jan about

Topicalization of finite argument clauses seems to be quite unrestricted. One exceptional case, taken from Odijk (1998), is given in (329). Although Odijk's judgment on (329b) is correct, it should be noted that example (329a) is an innovation in the language, as is clear from the fact that this use is not included in the latest (14<sup>th</sup>) edition of the Van Dale dictionary. Furthermore, many of our informants give an affirmative answer to the question as to whether (329a) should be considered an abbreviation of the more regular expression *Jan belde om te zeggen dat hij ziek was*; compare the translation of (329a) which was taken from Odijk's article. We therefore provisionally conclude that topicalization of finite argument clauses is always possible.

- (329) a. Hij belde [dat hij ziek was].  
 he called that he ill was  
 'He called to say that he was ill.'  
 b. \*[Dat hij ziek was] belde hij.

2. *Om + te-* and *te*-infinitival clauses

It is less clear to what extent *om + te-* and *te*-infinitival clauses can be preposed. Koster (1987:129) claims for *te*-infinitivals that this is “often difficult” and subsequently assigns them an asterisk. Zwart (1993:263) presents a case of topicalization of a *te*-infinitive as fully acceptable, while Odijk (1995:12) claims that such cases “are always somewhat marginal”; in later work, Zwart (2011:112) assigns two question marks to both topicalized *om + te-* and *te*-infinitival clauses. We agree that topicalization of *om + te-* and *te*-infinitivals normally gives rise to a marked result, but we also feel that topicalization leads to a markedly worse result in the case of *om + te-* infinitivals; this is what we try to express by means of our diacritics on the two singly-primed examples in (330). The left-dislocation constructions in the doubly-primed examples seem fully acceptable (although speakers again seem to vary somewhat in their judgments). Observe that the contrast between the singly- and doubly-primed examples is unexpected on the hypothesis that topicalization constructions are left-dislocation constructions with a deleted (phonetically empty) resumptive pronoun.

- (330) a. Jan<sub>i</sub> weigert [(om) PRO<sub>i</sub> weg te gaan]. [om + te-infinitival]  
 Jan refuses COMP away to go  
 ‘Jan refuses to leave.’  
 a'. \*?[(om) PRO<sub>i</sub> weg te gaan] weigert Jan<sub>i</sub>.  
 a''. [(om) PRO<sub>i</sub> weg te gaan], dat weigert Jan<sub>i</sub>.  
 b. Jan<sub>i</sub> probeert al tijden [PRO<sub>i</sub> de auto te repareren]. [te-infinitival]  
 Jan tries already ages the car to repair  
 ‘Jan has been trying for ages to repair the car.’  
 b'. ?[PRO<sub>i</sub> de auto te repareren] probeert Jan<sub>i</sub> al tijden.  
 b''. [PRO<sub>i</sub> de auto te repareren], dat probeert Jan<sub>i</sub> al tijden.

The examples in (330) involve direct object clauses. In (331), we give similar examples with a verb selecting a prepositional object.

- (331) a. Jan<sub>i</sub> klaagde (erover) [PRO<sub>i</sub> niet te kunnen komen].  
 Jan complained about.it not to be.able come  
 ‘Jan complained about not being able to come.’  
 b. \*[PRO<sub>i</sub> niet te kunnen komen] klaagde Jan<sub>i</sub> (erover).  
 c. [PRO<sub>i</sub> niet te kunnen komen] daar klaagde Jan<sub>i</sub> over.

Example (332) shows that omission of the pronominal part of the discontinuous PP *daar ... over* in the left-dislocation construction (331b) gives rise to a quite marked result for most speakers. This is again problematic for the claim that topicalization constructions are left-dislocation constructions with a phonetically empty resumptive element.

- (332) % [Niet te kunnen komen] klaagde Jan over.  
 not to be.able come complained Jan about

The discussion above is typical for opaque and semi-transparent infinitival clauses which may occur in extraposed position; cf. Section 5.2.2.3. There are a number of additional, complicating issues for transparent *te*-infinitivals, that is, infinitivals that

exhibit verb clustering and the °*infinitivus-pro-participio* effect. However, because topicalization of *te*-infinitival normally gives rise to a marked result and we can discuss the same issues by means of fully acceptable cases in which a bare infinitival clause is topicalized, we will address these issues in the next subsection.

### 3. *Bare infinitivals*

At first sight, topicalization of bare VPs seems easily possible, but closer scrutiny soon reveals that there are at least two complicating issues. The first issue is related to the fact that on general bare infinitival clauses are obligatorily split as a result of verb clustering. This phenomenon is illustrated in (333a) for the bare infinitival complement of the modal main verb *willen* ‘to want’. When we now consider the corresponding examples in (333b&c) notice to our surprise that clause splitting is optional (although we should note that *dat hij graag die problemen oplossen wil* is possible as a marked order). The primed examples are added to show that both topicalization constructions alternate with a left-dislocation counterpart, as predicted by the hypothesis that the topicalization constructions are left-dislocation constructions with a deleted (phonetically empty) resumptive pronoun.

- (333) a. *dat hij <die problemen> graag wil <\*die problemen> oplossen.*  
 that he those problems gladly wants prt.-solve  
 ‘that he dearly to solve those problems.’
- b. *Die problemen oplossen wil hij graag.*  
 b’. *Die problemen oplossen, dat wil hij graag.*  
 c. *Oplossen wil hij die problemen graag.*  
 c’. *Oplossen, dat wil hij die problemen graag.*

A second problematical factor is related to the *Infinitivus-Pro-Participio* (IPP) effect. Example (334a) first shows that in perfect-tense constructions the matrix verb does not appear as a past participle but as an infinitive. The singly-primed examples in (334) show that the IPP-effect disappears in the topicalization constructions, regardless of whether the infinitival clause is split or not. The primed examples show the same for the corresponding left-dislocation constructions.

- (334) a. *Hij had die problemen graag willen/\*gewild oplossen.*  
 he had those problems gladly want/wanted prt.-solve  
 ‘He had wanted to solve those problems very much.’
- b. *Die problemen oplossen had hij graag gewild/\*willen.*  
 b’. *Die problemen oplossen, dat had hij graag gewild/\*willen.*  
 c. *Oplossen had hij die problemen graag gewild/\*willen.*  
 c’. *Oplossen, dat had hij die problemen graag gewild/\*willen.*

The set of data in (333) and (334) thus shows that the core properties of constructions with transparent infinitives (clause splitting and IPP) disappear if the infinitival clause is topicalized. Although this has been known for a long time, there are still no theoretical accounts of it that meet with general acceptance. This is related to the current state of theories for these two phenomena. First, there are many competing theories on verb clustering that are more or less successful in describing the core data (see Section 7.5), but these are often quite different in

nature and therefore also require quite different approaches to the (b)- and (c)-examples in (333). Second, there are only a few theories available for the IPP-effect, and most of these are highly controversial, so that we can at best conclude from the data in (334) that the IPP-effect only arises if the embedded main verb is physically located in the verbal cluster, a suggestion supported by examples such as (335), which show that the IPP-effect must be preserved if the full (non-finite part of the) verb cluster is topicalized.

- (335) Willen/\*Gewild oplossen had hij die problemen graag.  
 want/wanted prt.-solve had he those problems gladly  
 'He had dearly wanted to solve those problems very much.'

We will return to the problem of clause splitting illustrated in examples (333b&c) in Subsection C on VP-topicalization, but have to leave the other questions and issues to future research.

The remainder of this subsection is devoted to an issue regarding topicalization of bare infinitival argument clauses that is more specifically related to accusativus-cum-infinitivo constructions such as (336a), in which we have again italicized the full complement clause. Example (336b'') shows that it is impossible to topicalize the full bare infinitival clause: the subject *die man* must remain in the middle field of the matrix clause. The two remaining (b)-examples show that the direct object *de boeken* can but need not be part of the topicalized phrase. Observe that we added the negative adverb *niet* 'not' to (336b''), as these topicalization constructions are natural only if the middle field contains some material next to the subject of the matrix verb.

- (336) a. dat hij *die man de boeken* niet zag stelen.  
 that he that man the books not saw steal  
 'that he didn't see the man steal the books.'  
 b. Stelen zag hij die man de boeken niet.  
 b'. De boeken stelen zag hij die man niet.  
 b''. \*Die man de boeken stelen zag hij niet.

One way of accounting for contrast between (336b') and (336b'') might be to appeal to the fact that while the object of the infinitival clause can be assigned accusative case by the infinitival verb *stelen* 'to steal', the subject of the infinitival clause must be assigned accusative case by the matrix verb *zien* 'to see', as is clear from the fact that it can be replaced by the object pronoun *hem* 'him'; cf. Section 5.2.3.3. It might be that topicalization as in (336b'') makes the latter, exceptional form of case assignment impossible; see Lasnik's (1999) discussion of "raising to object" in English for a line of thinking that may indeed have this effect. A potential (but not insurmountable) problem for this suggestion is that it is sometimes claimed that the subject can be part of the topicalized clause if it is indefinite, as in (337b''); cf. Odijk (1998:204). We again added the negative adverb *niet* 'not' to this example in order to make it more natural, but even then many speakers find examples like these highly questionable, for which reason we have assigned it a percentage sign.



- (337) a. dat hij *iemand de boeken zag stelen*.  
 that he someone the books saw steal  
 'that he saw someone steal the books.'  
 b. Stelen zag hij iemand de boeken.  
 b'. De boeken stelen zag hij iemand.  
 b''. <sup>0</sup>Iemand de boeken stelen zag hij niet.

### B. Adverbial clauses

From a syntactic point of view, topicalization of adverbial clauses seems quite unrestricted; we illustrate this in (338) for finite adverbial clauses of various kinds.

- (338) a. Voordat ik vertrek, bezoek ik mijn moeder. [temporal]  
 before I leave visit I my mother  
 'Before I leave, I will visit my mother.'  
 b. Omdat/Doordat Jan ziek is, gaat het feest niet door. [reason/cause]  
 because/because Jan ill is continue the party not prt.  
 'Because Jan is ill, the party is cancelled.'  
 c. Als je op deze knop drukt, gaat de computer aan. [conditional]  
 if one on this button presses goes the computer on  
 'If one presses this button, the computer starts up.'  
 d. Ondanks dat hij ziek was, was hij aanwezig. [concessive]  
 despite that he ill was was he present  
 'Despite his illness, he was present.'

This does not mean, however, that anything goes. Topicalization of an adverbial result clause such as (339a'), for instance, is distinctly odd. We marked this example with a dollar sign in order to indicate that its markedness is probably of a non-syntactic nature, and simply reflects the general tendency to present eventualities in the order of their actual occurrence: cf. *Jan stond op en kleeedde zich aan* 'Jan got up and dressed' versus <sup>\$</sup>*Jan kleeedde zich aan en stond op*. Example (339b') presents another marginal case of topicalization that can potentially be accounted for in a similar way.

- (339) a. Jan ging naar buiten zodat hij meer licht had. [result]  
 Jan went to outside so.that he more light had  
 'Jan went outside so that he would have more light.'  
 a'. <sup>\$</sup>Zodat hij meer licht had, ging hij naar buiten.  
 b. Je mag komen, mits je je gedraagt. [conditional]  
 you may come provided you REFL behave  
 'You may come provided that you behave.'  
 b'. <sup>\$</sup>Mits je je gedraagt, mag je komen.

The examples in (340) show that infinitival adverbial clauses are like finite ones in that they normally can be topicalized easily. Note in passing that goals differ from results in that they can be topicalized, which may be due to the fact that a goal comes into existence before the action that aims at realizing it.

- (340) a. Alvorens te vertrekken, bezoek ik mijn moeder. [temporal]  
 before to leave visit I my mother  
 ‘Before leaving, I will visit my mother.’  
 b. Om meer licht te krijgen, ging Jan naar buiten. [goal]  
 COMP more light to get went Jan to outside  
 ‘In order to get more light, Jan went outside.’

For completeness’ sake, we want to note that it is generally not easy to left-dislocate adverbial clauses; this is illustrated in (341a) for the temporal adverbial clause in (338a). Conditional clauses are a notable exception; this is illustrated in (341b) for the conditional clause in (338c).

- (341) a. \*Voordat ik vertrek, dan bezoek ik mijn moeder. [temporal]  
 before I leave then visit I my mother  
 ‘Before I leave, I will visit my mother.’  
 b. Als je op deze knop drukt, dan gaat de computer aan. [conditional]  
 if one on this button presses then goes the computer on  
 ‘If one presses this button, the computer starts up.’

The unacceptability of examples such as (341a) suggests that the hypothesis formulated for argument clauses that topicalization constructions are actually left-dislocation constructions with a deleted (phonetically empty) resumptive pronoun cannot readily be applied to adverbial clauses.

### C. Complements of non-main verbs (*VP*-topicalization)

The previous subsections have shown that (finite and infinitival) clauses functioning as clausal constituents can normally be topicalized. This subsection shows that the same holds for verbal complements of non-main verbs. We will discuss the three cases in (342), that is, non-main verbs that take a complement headed by a past/passive participle, a *te*-infinitive and a bare infinitive. Because these cases all involve contrastive accent on the topicalized phrase and all receive a contrastive interpretation, we may safely assume that we are dealing with focus constructions.

- (342) a. Hij heeft nooit geschaakt. [past/passive participle]  
 he has never played.chess  
 ‘He has never played chess.’  
 a’. GESCHAAKT heeft hij nooit.  
 b. Hij zit daar te schaken. [te-infinitive]  
 he sits there to play.chess  
 ‘He is playing chess over there.’  
 b’. <sup>3</sup>Te SCHAKEN zit hij daar.  
 c. Hij gaat morgen schaken. [bare infinitive]  
 he goes tomorrow play.chess  
 ‘He is going to play chess tomorrow.’  
 c’. SCHAKEN gaat hij morgen.

1. *Perfect tense and passive constructions*

Perfect tense constructions like (343a) easily allow topicalization of the perfect participle. The resulting construction in (343a') is potentially problematic as topicalization seems to affect a *single word*, while *wh*-movement normally affects *phrases*. The (b)-examples show, however, that it is also possible to topicalize verb phrases.

- (343) a. Hij heeft dat boek nog nooit gelezen.  
 he has that book yet never read  
 'He has never read that book.'
- a'. GELEZEN heeft hij dat boek nog nooit.
- b. Hij heeft nog nooit boeken gelezen.  
 he has yet never books read  
 'He has never read any books.'
- b'. [BOEKEN gelezen] heeft hij nog nooit.

Den Besten & Webelhuth (1987) argue that the contrast between the two primed examples in (343) is only apparent and that they both involve topicalization of a verb phrase (VP); the difference in size of the topicalized VP is merely a side effect of some other phenomenon of Dutch, viz. °scrambling. When we consider the two primeless examples in (343) we see that the direct objects occupy different locations: the definite object *dat boek* precedes the adverbial phrase *nog nooit* while the indefinite object *boeken* 'books' follows it. Den Besten & Webelhuth argue that this is due to leftward movement (scrambling) of the definite object to some position external to the VP; the two primeless examples in (343) thus have the (simplified) structures given in the primeless examples in (344). If these are the input for VP-topicalization, we end up with the structures in the primed examples.

- (344) a. Hij heeft dat boek<sub>i</sub> nog nooit [<sub>VP</sub> *t<sub>i</sub>* gelezen]. [scrambling of object]  
 he has that book yet never read
- a'. [<sub>VP</sub> *t<sub>i</sub>* GELEZEN]<sub>j</sub> heeft hij dat boek<sub>i</sub> nog nooit *t<sub>j</sub>*. [VP-topicalization]
- b. Hij heeft nog nooit [<sub>VP</sub> boeken gelezen]. [no scrambling of object]  
 he has yet never books read
- b'. [<sub>VP</sub> BOEKEN gelezen]<sub>j</sub> heeft hij nog nooit *t<sub>j</sub>*. [VP-topicalization]

On this view the apparent movement of the participle is the result of movement of the remnant of the VP *after* scrambling, and Den Besten & Webelhuth therefore refer to this type of topicalization as remnant VP-topicalization. There are various empirical arguments in favor of an analysis of this kind. First, we predict that elements that are difficult to scramble normally cannot be stranded by VP-topicalization either. This holds, e.g., for the complementive AP *ziek* 'ill' in the copular construction in (345); the examples in (345b&b') show that it must be taken along under VP-topicalization. For completeness' sake, we added (345b'') to show that the actual position of the complementive in the middle field does not affect the acceptability judgments.

- (345) a. Hij is <\*ziek> gelukkig niet <ziek> geworden.  
 he is ill fortunately not become  
 'Fortunately, he hasn't become ill.'

- b. [ZIEK geworden]<sub>j</sub> is hij gelukkig niet *t<sub>j</sub>*.
- b'. \*[*t<sub>i</sub>* Geworden]<sub>j</sub> is hij ziek<sub>i</sub> gelukkig niet *t<sub>j</sub>*.
- b''. \*[*t<sub>i</sub>* Geworden]<sub>j</sub> is hij gelukkig niet ziek<sub>i</sub> *t<sub>j</sub>*.

The examples in (346) show essentially the same for complementives like the AP *paars* 'purple' and the PP *in zijn spaarpot* 'in his money box' in resultative constructions (although it should be noted that these examples improve if the complementives are given emphatic accent). For completeness' sake, note that the structures in the primed examples are somewhat simplified, e.g., by not indicating the movement of the direct object; cf. (349) below.

- (346) a. Hij heeft het hek <\*paars> gisteren <paars> geverfd.  
 he has the gate purple yesterday painted  
 'Yesterday he painted the gate purple.'
- a'. [PAARS geverfd]<sub>j</sub> heeft hij het hek *t<sub>j</sub>*.
- a''. \*[*t<sub>i</sub>* GEVERFD] heeft hij het hek paars<sub>i</sub> *t<sub>j</sub>*.
- b. Hij heeft het geld <\*in zijn spaarpot> gisteren <in zijn spaarpot> gestopt.  
 he has the money in his money.box yesterday put  
 'Yesterday he put the money in his money box.'
- b'. [In zijn SPAARPOT gestopt]<sub>j</sub> heeft hij het geld *t<sub>j</sub>*.
- b''. \*[*t<sub>i</sub>* GESTOPT]<sub>j</sub> heeft hij het geld [in zijn spaarpot]<sub>i</sub> *t<sub>j</sub>*.

Second, we expect that elements that normally scramble into some more leftward position in the middle field must be stranded by VP-topicalization. The examples in (347) show that this prediction is borne out for weak (phonetically reduced) pronouns like *het* 'it'.

- (347) a. Hij heeft <het> nog nooit <\*het> gelezen.  
 he has it yet never read  
 'He has never read it yet.'
- b. [*t<sub>i</sub>* GELEZEN]<sub>j</sub> heeft hij het<sub>i</sub> nog nooit *t<sub>j</sub>*.
- b'. \*[Het GELEZEN]<sub>j</sub> heeft hij nog nooit *t<sub>j</sub>*.

Third, example (348a) shows that scrambling of the definite noun phrase *de auto* is optional (or, more precisely, depends on whether or not it introduces new information) and we therefore expect that it can optionally be stranded (again depending on its information-structural status). The (b)-examples show that this is again borne out.

- (348) a. Ik heb <de auto> gisteren <de auto> gerepareerd.  
 I have the car yesterday repaired  
 'Yesterday I repaired the car.'
- b. [*t<sub>i</sub>* GEREPAREERD]<sub>j</sub> heb ik de auto<sub>i</sub> wel *t<sub>j</sub>* (maar nog niet GEWASSEN).  
 repaired have I the car AFF but yet not washed  
 'I have REPAIRED the car (but I haven't WASHED it yet).'
- b'. [De AUTO gerepareerd]<sub>j</sub> heb ik wel *t<sub>j</sub>* (maar nog niet [het HEK geverfd]).  
 the car repaired have I AFF but yet not the gate painted  
 'I have repaired the car (but I haven't painted the gate yet).'

Finally, since scrambling need not affect all VP-internal elements equally, we expect that VP-topicalization may strand some of these elements while taking along some of the others. This was in fact already illustrated in (346), in which VP-topicalization takes along the complementive while stranding the direct object, which is base generated as the logical SUBJECT of the complementive phrase in a so-called small clause configuration; cf. Section 2.2. The remnant VP-topicalization approach would thus assign to these examples the structural representations in (349).

- (349) a.  $[[_{\text{SMALL CLAUSE}} t_i \text{ PAARS}] \text{ geverfd}]_j$  heeft hij het hek<sub>i</sub>  $t_j$ .  
 b.  $[[_{\text{SMALL CLAUSE}} t_i \text{ In zijn SPAARPOT}] \text{ gestopt}]_j$  heeft hij het geld<sub>i</sub>  $t_j$ .

The same can be shown by means of the double object construction in (350b): while the indirect object is stranded in the middle field of the clause, the direct object is still part of the topicalized VP.

- (350) a. De gemeente heeft de koning nog niet eerder een concert aangeboden.  
 the municipality has the king yet not before a concert prt.-offered  
 'The municipality hasn't yet offered the King a concert before.'  
 b.  $[t_i \text{ Een CONCERT aangeboden}]_j$  heeft de gemeente de koning<sub>i</sub> nog niet eerder  $t_j$ .

Example (351) provides one more example with the verb *beveiligen* 'to safeguard' that selects a direct and a prepositional object: in the primed example the PP-object is taken along under VP-topicalization, while the direct object is stranded.

- (351) a. Hij heeft zijn huis nog niet tegen inbraak beveiligd.  
 he has his house yet not against burglary safeguarded  
 'He hasn't safeguarded his house against burglary yet.'  
 b.  $[t_i \text{ Tegen INBRAAK beveiligd}]_j$  heeft hij zijn huis<sub>i</sub> nog niet  $t_j$ .

At first sight, it seems that extraposed complement clauses can optionally be stranded under VP-topicalization, which would be surprising given that such clauses normally do not scramble. This impression may be deceptive, however, because postverbal complement clauses can also be right-dislocated, as is clear (352a). They can be introduced by the anticipatory pronoun *het*. That pied piped clauses are extraposed while stranded clauses are left-dislocated is suggested by the fact that the former do not allow the addition of the anticipatory pronoun while the latter actually prefer it to be present.

- (352) a. Jan wil (het) niet beloven [dat hij komt].  
 Jan wants it not promise that he comes  
 'Jan doesn't want to promise (it) that he will come.'  
 b. [Beloven [dat hij komt]] wil hij (\*het) niet.  
 promise that he comes wants he it not  
 b'. [Beloven] wil hij ?(het) niet [dat hij komt].  
 promise wants he it not that he comes

The discussion above has shown that the remnant VP-topicalization approach is quite successful in accounting for a number of core properties of VP-topicalization. There are, however, also a number of potential problems. We restrict our discussion

here to one problem that can be illustrated on the basis of Standard Dutch, and refer the reader to Haider (1990) for a number of potential problems more specifically related to German. The problem in question, which was signaled by Den Besten & Webelhuth (1990), concerns the position of stranded prepositions. Section P5.3 has shown that stranded prepositions must be adjacent to the verb(s) in clause-final position. This suggests that they occupy a VP-internal position and we therefore expect that they must be taken along under VP-topicalization, but this is not borne out. The (b)-examples in (353) illustrate this by means of the discontinuous pronominal PP *er ..op* 'on it'.

- (353) a. Hij had er niet op gerekend.  
           he had there not on counted  
           'He hadn't counted on it.'  
       b. GEREKEND had hij er niet op.  
       b'. \*OP gerekend had hij er niet.

It must be noted, however, that this problem only occurs on the traditional assumption that PP-complements are base-generated as complements of verbs, but that it has been argued on independent grounds that PP-complements are actually base-generated external to the lexical projection of the verb (cf. Barbiers 1995:ch.4), or perhaps even created in the course of the derivation (cf. Kayne 2004). If we adopt one of these proposals, the pattern in (353) is in fact expected: see Broekhuis (2008:115ff.) and references cited there.

The primed examples in (354) show that passive constructions also allow topicalization of the participle. Again we may assume that we are dealing with topicalization of VPs in both cases, although the VP-internal traces are now coindexed with the noun phrase that has been promoted to subject.

- (354) a. Dat boek wordt niet meer gelezen.  
           that book is no longer read  
           'That book isn't read any more.'  
       a'. [<sub>*t*<sub>i</sub></sub> GELEZEN]<sub>*j*</sub> wordt dat boek<sub>*i*</sub> niet meer *t*<sub>*j*</sub>.  
       b. Zijn huis is nog niet tegen inbraak beveiligd.  
           his house is yet not against burglary safeguarded  
           'His house is not yet burglarproof.'  
       b'. [<sub>*t*<sub>i</sub></sub> Tegen INBRAAK beveiligd]<sub>*j*</sub> is zijn huis<sub>*i*</sub> nog niet *t*<sub>*j*</sub>.

It seems that the subject of a passive construction can sometimes marginally remain VP-internal if it is indefinite, but then the regular subject position is normally filled by the expletive *er* if the middle field does not contain any presuppositional material.

- (355) a. Er worden bijna geen boeken meer gelezen.  
           there are almost no books any.more read  
           'Books are hardly read any more.'  
       b. [BOEKEN gelezen] worden \*(<sup>?</sup>er) bijna niet meer.  
           books read are there almost not any.more

Haider (1990) claims for German that indefinite subjects of active monadic verbs can also be taken along by VP-topicalization (which would be in line with the current view that such subjects are base-generated in a VP-internal position). This gives rise to a rather marginal result in Dutch, as is illustrated in the (a)-examples for the intransitive verb *spelen* ‘to play’ and in the (b)-examples for the unaccusative verb *sterven* ‘to die’.

- (356) a. Er hebben hier nog nooit kinderen gespeeld. [intransitive]  
 there have here yet never children played  
 ‘Children have never played here.’  
 a’. \*[Kinderen gespeeld]<sub>i</sub> hebben (er) hier nog nooit *t<sub>i</sub>*.  
 b. Er zijn daardoor nog nooit patiënten gestorven. [unaccusative]  
 there are by.that yet never patients died  
 ‘Patients have never died because of that so far.’  
 b’. \*[Patiënten gestorven]<sub>i</sub> zijn (er) daardoor nog nooit *t<sub>i</sub>*.

Haider also claims that indefinite subjects of dyadic verbs can be taken along under VP-topicalization provided that the object is stranded. The primed examples in (357) show that this is impossible in Dutch if the verb is transitive, while it gives rise to a marginal result if it is unaccusative (that is, a NOM-DAT verb).

- (357) a. Er heeft nog nooit een buitenlander die derby gewonnen. [transitive]  
 there has yet never a foreigner that derby won  
 ‘A foreigner has never won that derby so far.’  
 a’. \*[Een buitenlander *t<sub>i</sub>* gewonnen]<sub>j</sub> heeft [die (derby)]<sub>i</sub> nog nooit *t<sub>j</sub>*.  
 b. Er is hem nog nooit een ongeluk overkomen. [NOM-DAT verb]  
 there is him yet never an accident happened  
 ‘He has never had an accident so far.’  
 b’. <sup>??</sup>[*t<sub>i</sub>* Een ongeluk overkomen]<sub>j</sub> is hem<sub>i</sub> nog nooit *t<sub>j</sub>*.

The acceptability contrast between the two primed examples in (357) can probably be attributed to the fact that Standard Dutch does not allow the object of a transitive verb to scramble across the subject, while is quite normal for the object to precede the subject in clauses headed by NOM-DAT verbs; cf. Section 2.1.3. This contrast can therefore be taken as support for the remnant VP-topicalization approach.

## 2. *Te*-infinitives

Subsection A has shown that topicalization of *te*-infinitival clauses is normally at least somewhat marked. The same seems to hold for *te*-infinitival complements of the semi-aspectual verbs like *zitten* ‘to sit’. As in perfect and passive constructions, the direct object of the main verb may be taken along with VP-topicalization or be stranded in the middle field, depending on whether it expresses “new” or presupposed information. Judgments on the primed examples seem to vary from speaker to speaker and range from marked to ungrammatical; the examples seem to improve if some element in the middle field of the clause can be assigned emphatic accent: cf. <sup>?</sup>*Te* LEZEN zit hij dat boek altijd HIER.



- (358) a. Hij zit hier altijd boeken te lezen.  
 he sits here always books to read  
 'He is always reading books here.'  
 a'. ?[BOEKEN te lezen] zit hij hier altijd.  
 b. Hij zit dat boek altijd hier te lezen.  
 he sits that book always here to read  
 'He is always reading that book here.'  
 b'. ?[<sub>t<sub>i</sub></sub> Te lezen] zit hij dat boek<sub>i</sub> altijd hier.

It seems that VP-topicalization of verbal projections headed by a *te*-infinitive exhibits more or less the same properties as topicalization of verbal projections headed by a past/passive participle, but we will not illustrate this here because all examples are minimally perceived as marked.

### 3. Bare infinitives

Topicalization of bare infinitival complements of non-main verbs like the aspectual verbs inchoative *gaan* 'to go', *komen* 'to come', and *blijven* 'to stay' is easily possible. As in perfect and passive constructions, the direct object of the main verb may be taken along with VP-topicalization or be stranded in the middle field of the clause, depending on whether it expresses new or presupposed information.

- (359) a. Hij gaat vandaag bloemen plukken.  
 he goes today flowers pick  
 'He is going to pick flowers today.'  
 a'. [BLOEMEN plukken]<sub>i</sub> gaat hij vandaag <sub>t<sub>i</sub></sub>.  
 b. Hij gaat de bloemen vandaag plukken.  
 he goes the flowers today pick  
 'He is going to pick the flowers today.'  
 b'. [<sub>t<sub>i</sub></sub> PLUKKEN]<sub>j</sub> gaat hij de bloemen<sub>i</sub> vandaag <sub>t<sub>j</sub></sub>.

It seems that the remnant VP-topicalization approach is also descriptively adequate for cases of this type. The examples in (360) first show that elements such as the complementives *paars* and *in zijn spaarpot*, which are normally not scrambled, are taken along by the preposed VP. The doubly-primed examples improve a little bit if the complementive is assigned emphatic stress.

- (360) a. Hij gaat het hek paars verven.  
 he goes the gate purple paint  
 'He is going to paint the gate purple.'  
 a'. PAARS verven gaat hij het hek.  
 a''. \*VERVEN gaat hij het hek paars.  
 b. Hij gaat het geld in zijn spaarpot stoppen.  
 he goes the money in his money.box put  
 'He is going to put the money in his money box.'  
 b'. In zijn SPAARPOT stoppen gaat hij het geld.  
 b''. \*STOPPEN gaat hij het geld in zijn spaarpot.

Because the direct objects originate as logical SUBJECTS of the complementives, the singly-primed examples also show that VP-topicalization may take along some VP-internal element while stranding other VP-internal elements (here: the direct object) in the middle field of the clause. This is shown in the simplified structures of these examples in (361).

- (361) a. [[<sub>SMALL CLAUSE</sub>  $t_i$  PAARS] verven]<sub>j</sub> gaat hij het hek<sub>i</sub>  $t_j$ .  
 b. [[<sub>SMALL CLAUSE</sub>  $t_i$  In zijn SPAARPOT] stoppen]<sub>j</sub> gaat hij het geld<sub>i</sub>  $t_j$ .

A similar apparent VP-split can be shown by means of the double object construction in (362b): while the indirect object is stranded in the middle field of the clause, the direct object is still part of the topicalized VP.

- (362) a. De gemeente gaat de koning volgende week een concert aanbieden.  
 the municipality goes the King next week a concert prt.-offer  
 'The municipality is going to offer the King a concert next week.'  
 b. [ $t_i$  Een CONCERT aanbieden]<sub>j</sub> gaat de gemeente de koning<sub>i</sub> volgende week  $t_j$ .

Example (363) provides one more example with the verb *beveiligen* 'to safeguard' that selects a direct and a prepositional object: in the primed example the PP-object is taken along under VP-topicalization, while the direct object is stranded.

- (363) a. Hij gaat zijn huis snel tegen inbraak beveiligen.  
 he goes his house soon against burglary safeguard  
 'He is going to safeguard his house against burglary soon.'  
 b. [ $t_i$  Tegen INBRAAK beveiligen]<sub>j</sub> gaat hij zijn huis<sub>i</sub> snel  $t_j$ .

The fact that stranded prepositions cannot be part of the preposed VP is again potentially problematic for the remnant VP-topicalization approach, but we have already mentioned that this is in fact expected under some more recent hypotheses concerning the nature of PP-complements.

- (364) a. Hij gaat er niet op wachten.  
 he goes there not for wait  
 'He is not going to wait for it.'  
 b. WACHTEN gaat hij er niet op.  
 b'. \*Op wachten gaat hij er niet.

The examples in (365) show that indefinite subjects can only marginally be part of topicalized VPs if the main verb is monadic, and the examples in (366) show that in the case of dyadic verbs we find again a contrast in this respect between transitive and unaccusative (NOM-DAT) verbs.

- (365) a. Er komen volgende week kinderen spelen. [intransitive]  
 there come next week children play  
 'Children are going to play here next week.'  
 a'. \*[Kinderen spelen]<sub>j</sub> komen (er) volgende week  $t_i$ .  
 b. Er gaan daardoor patiënten sterven. [unaccusative]  
 there go by.that patients die  
 'Patients are going to die because of that.'  
 b'. \*[Patiënten sterven]<sub>j</sub> gaan (er) daardoor  $t_i$ .

- (366) a. Er gaat nooit een buitenlander die derby winnen. [transitive]  
 there goes never a foreigner that derby win  
 ‘A foreigner is never going to win that derby.’  
 a’. \*[Een buitenlander  $t_i$  winnen] $_j$  gaat [die (derby)] $_i$  nooit  $t_j$ .  
 b. Er gaat hem iets naars overkomen. [NOM-DAT verb]  
 there goes him something nasty happen  
 ‘Something nasty is going to happen to him.’  
 b’. ??[ $t_i$  iets naars overkomen] $_j$  gaat hem $_i$  niet  $t_j$ .

The examples above make it clear that VP-topicalization of bare infinitives exhibits more or less the same behavior as VP-topicalization of past/passive participles.

#### 4. A special case

The examples in (367) provide a special case of VP-topicalization: these examples show that VP-topicalization can also occur if there is no non-main verb, but that in the resulting structure the verb-second position must be filled by the “dummy” verb *doen* ‘to do’. As the second position of the clause can only be occupied by finite verbs, tense and agreement cannot be expressed by the main verb but must be transferred to a finite form of *doen*. We refer the reader to Section 6.4.3 for more discussion of this “dummy” use of *doen*.

- (367) a. Hij verkoopt zijn postzegels beslist niet.  
 he sells his stamps definitely not  
 ‘He definitely won’t sell his stamps.’  
 a’. [ $t_i$  Verkopen] $_j$  doet hij zijn postzegels $_i$  beslist niet  $t_j$ .  
 sell does he his stamps definitely not  
 b. Hij verzamelt geen postzegels meer.  
 he collects no stamps any.more  
 ‘He doesn’t collect stamps any more.’  
 b’. [Postzegels verzamelen] $_i$  doet hij niet meer  $t_i$ .  
 stamps collect does he not any.more

#### 5. VP-topicalization and left dislocation

This subsection has provided a discussion of VP-topicalization based on Den Besten & Webelhuth’s (1987) remnant VP-topicalization approach, according to which VP-topicalization can be preceded by scrambling of VP-internal material. The attractive appeal of this approach is that it immediately accounts for the fact that the elements stranded in the middle field of the clause can be semantically licensed by the verb heading the VP in clause-initial position, as these stranded elements are base-generated within this VP. The fact that the noun phrase *dat boek* in (368a) is interpreted as the theme argument of *lezen* ‘to read’ is simply due to the fact that this thematic role is assigned to the position occupied by its trace  $t_i$ , that is, the position originally held by this noun phrase. The two examples in (368) therefore do not differ in any crucial way when it comes to the assignment of thematic roles.

- (368) a. [<sub>VP</sub> *t<sub>i</sub>* GELEZEN]<sub>j</sub> heeft hij dat boek<sub>i</sub> nog nooit *t<sub>j</sub>*.  
           read      has  he  that book yet never  
           ‘He has never read that book yet.’
- b. [<sub>VP</sub> BOEKEN gelezen]<sub>i</sub> heeft hij nog nooit *t<sub>i</sub>*.  
           books  read      has  he  yet  never  
           ‘He has never read books yet.’

All acceptable VP-topicalization constructions discussed in the previous subsections alternate with left-dislocation constructions; the addition of the resumptive pronoun *dat* ‘that’ never affects the acceptability judgments given in the previous subsection for the topicalization construction. This is illustrated in (369) for the examples in (368).

- (369) a. [<sub>VP</sub> *t<sub>i</sub>* GELEZEN], DAT heeft hij dat boek<sub>i</sub> nog nooit *t<sub>j</sub>*.  
           read          that has  he  that book yet never  
           ‘He has never read that book yet.’
- b. [Boeken gelezen], DAT heeft hij nog nooit.  
           books  read      that has  he  yet  never  
           ‘He has never read books yet.’

Such left-dislocation constructions potentially undermine the argument in favor of the remnant VP-topicalization approach based on the assignment of thematic roles because they may force us to introduce some special mechanism to account for the fact that the “stranded” elements are interpreted as part of the clause-external, left-dislocated VP. So, if we introduce a special mechanism to account for the fact that the noun phrase *dat boek* ‘that book’ in (369a) is interpreted as the direct object of the participle *gelezen*, we do not have to appeal to scrambling in order to account for the fact that the same holds for example (368a). It should be noted, however, that there are also proposals according to which left-dislocation is simply a special case of topicalization; in such analyses, which will be discussed in Section 14.2, sub VII/VIII, the argument based on the assignment of thematic roles can probably be maintained in full force.

Moreover, much is still not well-understood. Müller (1998:221), for instance, approvingly cites unpublished work by Truckenbrodt that shows that German behaves more in accordance with what is predicted by Den Besten & Webelhuth’s (1987) proposal in allowing constructions like (369b), in which the left dislocated phrase is a “full” VP, but prohibiting constructions like (369a), in which the left-dislocated phrase is a remnant VP. In fact, some speakers report the same for cases in which a bare infinitival complement is topicalized/left-dislocated. The examples in (370a) first show that topicalization is fully acceptable to all speakers of Dutch, whereas the corresponding left-dislocation construction (370b) seems degraded. Note further the left dislocation becomes acceptable to all speakers if we insert the “dummy” verb *doen*; the topicalization construction, on the other hand, is not compatible with *doen* in Standard Dutch.

- (370) a. Lezen gaat hij die boeken niet (\*doen).  
           read  goes he those books not  do  
           ‘He isn’t going to read those books.’

- b. Lezen, dat gaat hij die boeken niet <sup>??</sup>(doen).  
 read that goes he those books not do  
 'He isn't going to read those books.'

Second, the examples in (371) show that most speakers consider left dislocation at least marginally acceptable if the preposed VP contains the direct object (see Odijk 1995), although they may still prefer the addition of the "dummy" verb *doen*. Adding *doen* to the topicalization construction is impossible. For completeness' sake, note that (371a) can be construed as a topic drop construction, provided that the phrase *boeken lezen* is followed by an intonation break.

- (371) a. Boeken lezen gaat hij niet (\*doen).  
 books read goes he not do  
 'He isn't going to read books.'  
 b. Boeken lezen, dat gaat hij niet <sup>?</sup>(doen).  
 books read that goes he not do  
 'He isn't going to read books.'

VP-topicalization constructions such as (372) with a finite form of "dummy" *doen* 'to do' in second position do not seem to raise similar restrictions as constructions with a non-main verb: the two left-dislocation constructions in (372) seem to be equally acceptable for most speakers.

- (372) a. Verkopen doet hij zijn postzegels beslist niet.  
 sell does he his stamps definitely not  
 'He is definitely not selling his stamps.'  
 a'. Verkopen, dat doet hij zijn postzegels beslist niet.  
 sell that does he his stamps definitely not  
 'He is definitely not selling his stamps.'  
 b. Postzegels verzamelen doet hij niet meer.  
 stamps collect does he not any.more  
 'He doesn't collect stamps anymore.'  
 b'. Postzegels verzamelen, dat doet hij niet meer.  
 stamps collect that does he not any.more  
 'He doesn't collect stamps anymore.'

The discussion above shows that more research is needed in order to clarify the relation between VP-topicalization and left-dislocation, as well as its implications for the remnant VP-topicalization approach adopted in the discussion above. We refer the reader to Müller (1998) for additional arguments in favor of this approach, and Haider (1990) and Fanselow (2002) for arguments against it based on German.

#### D. Conclusion

The previous subsections have shown that, broadly speaking, it is possible to topicalize finite clauses. Infinitival clauses exhibit a more varied behavior: *om* + *te*-infinitivals seem to resist topicalization, while topicalization of bare infinitivals is fully acceptable; judgments on topicalization of *te*-infinitivals seem to vary from speaker to speaker but these topicalizations are normally considered marginal, or marked at least. VP-topicalization, that is, topicalization of the complements of non-

main verbs, is possible if these are headed by a past/passive participle or a bare infinitive, and again marked in the case of *te*-infinitives. To our knowledge there are no theoretical proposals that aim at accounting for this pattern.

We also investigated whether the topicalization constructions discussed in the previous subsections alternate with left-dislocation constructions, since it is often claimed that the former are actually derived from the latter by deletion of the resumptive element. This claim is not fully supported by the empirical facts, which are summarized in Table 1.

Table 1: *Topicalization and left dislocation of clauses and other verbal projections*

		TOPICALIZATION	LEFT DISLOCATION
FINITE	argument (SU, DO)	✓	✓
	argument (PP)	*	✓
	adverbial	✓	*
	adverbial (conditional)	✓	✓
INFINITIVAL	<i>om</i> + <i>te</i> -infinitive	*	✓
	<i>te</i> -infinitives	?	✓
	bare infinitives	✓	✓
VP- TOPICALIZATION	past/passive participle	✓	✓
	<i>te</i> -infinitival	?	?
	bare infinitival (full)	✓	✓
	bare infinitival (remnant)	✓	?

### VII. Some differences between English and Dutch topicalization

English topicalization and Dutch topicalization seem to differ in various non-trivial respects. First consider the English examples in (373). The (a)-examples show that while *wh*-movement of the interrogative object *which book* triggers subject-verb inversion (or *do*-support if there is no auxiliary verb) in main clauses, topicalization of the direct object *this book* does not. The (b)-examples show that while *wh*-phrases like *which book* cannot co-occur with a complementizer in embedded clauses, topicalized phrases can although the result is marginal for some speakers. Note that whereas the *wh*-phrase is normally assumed to precede the empty complementizer position, the topicalized phrase must follow the complementizer.

- (373) a. Which book should I read?  
 a'. This book, you should read.  
 b. I wonder [which book (\*that) I should read].  
 b'. %I believe [that this book you should read].

Chomsky (1977) proposed that topicalization in English is like question formation in that it is derived by means of *wh*-movement (but see Baltin 1982 and Lasnik & Saito 1992 for alternative proposals). His analysis is given in a slightly adapted form as (374), where “Topic” refers to the topicalized phrase, which is associated to the following clause by being coindexed with a phonetically empty operator that is *wh*-moved into clause-initial position.

- (374) Topic<sub>i</sub> [<sub>CP</sub> OP<sub>i</sub> C [<sub>TP</sub> ... t<sub>i</sub> ...]]

If we assume that the topicalized phrase indicated by “Topic” is a sentence-external element, the structural representation in (374) is able to account for a number of characteristic properties of Dutch topicalization. First, the Dutch counterparts of the (a)-examples in (373) given in (375) show that Dutch topicalization behaves like question formation in that it obligatorily triggers subject-verb inversion.

- (375) a. Welk boek<sub>i</sub> moet ik *t*<sub>i</sub> lezen?  
 which book must I read  
 b. Dit boek<sub>i</sub> [<sub>CP</sub> OP<sub>i</sub> moet je *t*<sub>i</sub> lezen].  
 this book must you read

Second, topicalization exhibits the typical qualities of *wh*-movement: example (376) shows that it is not clause-bound but nevertheless island-sensitive in that it cannot be extracted from an embedded question or an adjunct clause.

- (376) a. Dit boek<sub>i</sub> [<sub>CP</sub> OP<sub>i</sub> denk ik [<sub>CP</sub> dat ik *t*<sub>i</sub> moet lezen]].  
 this book think I that I must read  
 b. \*Dit boek<sub>i</sub> [<sub>CP</sub> OP<sub>i</sub> vraag ik me af [<sub>CP</sub> of ik *t*<sub>i</sub> moet lezen]].  
 this book wonder I REFL prt. if I must read  
 c. \*Dit boek<sub>i</sub> [<sub>CP</sub> OP<sub>i</sub> huil ik [<sub>CP</sub> omdat ik *t*<sub>i</sub> moet lezen]].  
 this book cry I because I must read

Third, the examples in (377) show that Dutch topicalization differs from question formation in that it is categorically rejected in embedded clauses (contrary to what has been shown for English in the (b)-examples in (373)). This would follow immediately if we assume that the topicalization structure in (374) cannot be embedded: this is illustrated in (377b) for an embedded clause with the finite verb in clause-final position and in (377b') for an embedded clause with verb-second (which is an acceptable option in German).

- (377) a. Ik vraag me af [welk boek (of) ik *t*<sub>i</sub> moet lezen].  
 I wonder REFL prt. which book COMP I must read  
 b. \*Ik denk [<(dat)> dit boek<sub>i</sub> (<dat>) je *t*<sub>i</sub> moet lezen].  
 I think that this book that you must read  
 b'. \*Ik denk [dit boek<sub>i</sub> moet je *t*<sub>i</sub> lezen].  
 I think this book must you read

The analysis in (374) treats topicalization in essentially the same way as the left-dislocation constructions in (378); the only difference is that topicalization involves a phonetically empty operator or, alternatively, derives it from examples like (378) by deletion of the phonetic content of the *wh*-moved element.

- (378) a. Dit boek<sub>i</sub> [<sub>CP</sub> dat<sub>i</sub> moet je *t*<sub>i</sub> lezen]]. [cf. (375b)]  
 this book that must you read  
 ‘This book you should read it.’  
 b. Dit boek<sub>i</sub> [dat<sub>i</sub> denk ik [dat ik *t*<sub>i</sub> moet lezen]]. [cf. (376a)]  
 this book that think I that I must read  
 ‘This book, I think I should read it.’



The strongest hypothesis would therefore be that left dislocation of the type in (378) and topicalization alternate freely. This hypothesis does not seem to be tenable, however, given that there are certain differences between the two constructions. The examples in (379), for instance, show that while topicalization of quantified expressions like *iedereen* ‘everyone’ and *niemand* ‘no one’ can easily be realized, they cannot occur in left-dislocation constructions. This requires the additional *ad hoc* stipulation that the empty operator and the overt pronoun differ in that only the latter prohibits a quantified antecedent; we refer the reader to Section 14.2 for more examples.

- (379) a. *Iedereen<sub>i</sub> [OP<sub>i</sub>/\*die<sub>i</sub> heb ik t<sub>i</sub> gezien (behalve Peter)].*  
 everyone OP/them have I seen except Peter  
 ‘I have seen everyone (except Peter).’  
 b. *Niemand<sub>i</sub> [OP<sub>i</sub>/\*die<sub>i</sub> heb ik t<sub>i</sub> gezien (behalve Peter)].*  
 no.one OP/them have I seen except Peter  
 ‘I have seen no one (except Peter).’

Example (380) further shows that the analysis in (374) requires that we assume that the *wh*-moved empty operator cannot strand a preposition. This is again *ad hoc* since examples like (380b) show that empty operators are normally able to do this; see Section A6.5.4.1 for an extensive discussion of such constructions.

- (380) a. *Deze schoenen<sub>i</sub> [daar<sub>i</sub>/\*OP<sub>i</sub> voetbalt Peter [t<sub>i</sub> mee]].*  
 these shoes there/OP plays.soccer Peter with  
 ‘These shoes, Peter plays soccer with them.’  
 b. *Deze schoenen<sub>i</sub> zijn zeer geschikt [OP<sub>i</sub> om PRO [t<sub>i</sub> mee] te voetballen].*  
 these shoes are very suitable COMP with to play.soccer  
 ‘These shoes are very suitable suitable for playing soccer.’

The contrasts in (379) and (380) casts serious doubts on the analysis in (374), especially because they follow without much ado under the alternative analysis, according to which topicalization involves *wh*-movement of the topicalized phrase itself. The unacceptability of examples (381a’&b’), for example, can simply be accounted for by the independently motivated assumption that demonstrative pronouns like *die* normally cannot refer to quantified phrases (if we ignore so-called °bound variable readings); cf. *\*Niemand<sub>i</sub> was aanwezig, maar die<sub>i</sub> werd niet gemist*. And the contrast between the two (c)-examples follows from the well-established fact that prepositions can only be stranded if the PP undergoes °R-pronominalization.

- (381) a. [*Iedereen<sub>i</sub> heb ik t<sub>i</sub> gezien (behalve Peter)*].  
 a’. *\*Iedereen<sub>i</sub> [die<sub>i</sub> heb ik t<sub>i</sub> gezien (behalve Peter)]*.  
 b. [*Niemand<sub>i</sub> heb ik gezien (behalve Peter)*].  
 b’. *\*Niemand<sub>i</sub> [die<sub>i</sub> heb ik gezien (behalve Peter)]*.  
 c. *\*Deze schoenen<sub>i</sub> voetbalt Peter [t<sub>i</sub> mee]*.  
 c’. *Deze schoenen<sub>i</sub> [daar<sub>i</sub> voetbalt Peter [t<sub>i</sub> mee]]*.

Of course, rejection of (374) as the proper structural representation of topicalization constructions also has its problems. For example, it would result in the loss of the elegant account for the fact that the Dutch topicalization is a root phenomenon, that is, that it applies in main clauses only. For this reason, it seems premature to make a definitive choice between the two options and we therefore leave this issue to future research. The reader is referred to Section 14.2 for a more extensive discussion of left dislocation.

#### 11.3.4. *Wh*-exclamatives

Exclamations can be made in many ways. In this section we are particularly interested in exclamative clauses with a designated exclamative element in first position. These are called *wh*-exclamatives because the designated element is a *wh*-word such as *wat* ‘what’ in (382); see Section A3.1.2, sub V, for a more extensive discussion of the distribution of this element. We will ignore the use of *welk(e)* ‘which’ and *hoe* ‘how’ found in formal language and writing: cf. <sup>S</sup>*Welk een dwaasheid (is dat)!* ‘what folly that is!’ and <sup>S</sup>*Hoe spannend (is dat)!* ‘How exciting that is!’.

- |          |  |     |  |
|----------|--|-----|--|
| (382) a. | Wat ben jij sterk!<br>what are you strong<br>‘How strong you are!’ | a’. | Wat ben jij een sterke vrouw!<br>what are you a strong woman<br>‘What a strong woman you are!’ |
| b.       | Wat sterk ben jij!<br>what strong are you<br>‘How strong you are!’ | b’. | Wat een sterke vrouw ben jij!<br>what a strong woman are you<br>‘What a strong woman you are!’ |

Subsection I starts with a discussion of the semantics of *wh*-exclamatives on the basis of examples like (382a&a’); we will show that although it is generally assumed that *wh*-exclamatives give rise to an extremely-high-degree or an extremely-high-quantity reading, their meaning can be more adequately expressed in terms of “higher than expected”. Subsection II discusses two syntactic subtypes of *wh*-exclamative clauses, which are illustrated by, respectively, the (a)- and (b)-examples in (382). The first type is characterized by the fact that the first position of the clause is occupied by the exclamative *wh*-element only, while in the second type the exclamative *wh*-element is part of a larger phrase in initial position. This may give rise to the hypothesis that the exclamative *wh*-element is base-generated as part of a larger phrase, and that the (a)-examples are derived by stranding part of this larger phrase, while the (b)-examples are derived by °pied piping it. We will show that this hypothesis is not viable and, more specifically, that the (a)-examples are in fact not derived by *wh*-movement at all. Subsection III continues by showing that *wh*-exclamatives can also be embedded but that this requires the exclamative element to be embedded in a larger phrase in the initial position of the embedded clause; this is illustrated in the examples in (383). Furthermore the exclamative element may be different: while in main clauses the *wh*-element is always *wat* in colloquial speech, example (383a) shows that it sometimes must be realized as *hoe* ‘how’ in embedded contexts.

- (383) a. Ik was vergeten [hoe/\*wat sterk jij bent].  
 I was forgotten how/what strong you are  
 'I had forgotten how strong you are.'
- a'. \*Ik was vergeten [hoe/wat jij sterk bent].  
 I was forgotten how/what you strong are
- b. Ik was vergeten [wat een sterke vrouw jij bent].  
 I was forgotten what a strong woman you are  
 'I had forgotten what a strong woman you are.'
- b'. \*Ik was vergeten [wat jij een sterke vrouw bent].  
 I was forgotten what you a strong woman are

The *wh*-exclamatives discussed in this section are merely instances of a wider range of constructions that can be used as exclamations. It is not the case, however, that all exclamations are relevant for syntactic descriptions; an exclamation such as *Bah!* 'Yuk!', for example, should rather be described in lexicographic terms. Subsection IV will provide a review of such constructions and discuss the question as to whether the various types should be given a syntactic or some other account. For want of in-depth syntactic investigations, this review will be necessarily of a preliminary nature.

### *I. Meaning*

This subsection discusses the meaning of *wh*-exclamative constructions. It is often claimed that such exclamatives have an "extremely high degree" or an "extremely large quantity" reading, and Subsections A to C therefore start with a discussion of these prototypical readings. It has been suggested, however, that these readings do not constitute the core meaning of *wh*-exclamatives but are derived from two more basic properties: (i) *wh*-exclamatives are like *wh*-questions in that they behave semantically as operator-variable constructions (see Subsections A to C), and (ii) they are factive in the sense that the speaker presupposes the proposition expressed by the non-*wh*-part of the exclamative to be true (subsection D). Subsection E will show that this enables us to derive a range of context-sensitive interpretations that can be characterized as "higher-than-expected-degree" or "larger-than-expected-quantity" readings.

#### *A. The extremely-high-degree reading*

*Wh*-exclamatives often express an extremely high degree. This can be illustrated by means of example (384a), in which the exclamative *wh*-element *wat* 'what' expresses that the addressee has worked to a degree that exceeds a certain contextually given norm. This extremely-high-degree reading arises only if the *wh*-element does not function as an independent clausal constituent; cf. Bennis (1995/1998). In (384b), for instance, the *wh*-element *hoe* 'how' functions as a manner adverb and this leads to an interrogative interpretation. Similarly, the *wh*-element *wat* functions as a direct object in (384c) and the construction must again be interpreted as a question. Ignore the elements  $\Delta_i$  and  $t_i$  in (384), which will be discussed shortly.

- (384) a. Wat<sub>i</sub> heb jij vandaag Δ<sub>i</sub> gewerkt! [wh-exclamative]  
 what have you today worked  
 ‘Boy, how you have worked today!’
- b. Hoe<sub>i</sub> heb jij vandaag t<sub>i</sub> gewerkt? [wh-interrogative]  
 how have you today worked  
 ‘How did you work today?’
- c. Wat heb je gedaan? [wh-interrogative]  
 what have you done  
 ‘What have you done?’

Nevertheless, Corver (1990) and Zanutinni & Portner (2003) hypothesize that *wh*-phrases in questions and exclamatives perform a comparable function; they are operators that bind some variable in the clause. This means that questions and exclamations are similar in that they both denote open propositions or, in other words, sets of alternative propositions. The manner adverb *hoe* ‘how’ in question (384b), for instance, gives rise to an open proposition that denotes a set of alternative propositions that differ in manner: the addressee may have worked well, badly, hard, with pleasure, with reluctance, etc. The exclamative construction in (384a) can likewise be seen as an open proposition, but in this case the alternative propositions differ in degree (here: intensity) only, for which reason we have represented the variable by means of the Greek capital Δ. The representation in (384a) of course does not yet answer the question as to why this example is normally used to express an *extremely high* degree, that is, that the addressee has worked *exceptionally* hard. We will return to this question in Subsection D.

We have claimed above that exclamative *wat* in (384a) does not function as a clausal constituent. In order to substantiate this, we should show that *wat* differs from *hoe* in (384b) in that it cannot be used as a manner adverb. A first reason for assuming this is that (384a) does not allow an interrogative interpretation: if the *wh*-phrase *wat* were a manner adverbial, this would of course be quite surprising. Another reason is that exclamative *wat* is also possible if a manner adverb is overtly expressed; this is shown in (385a), in which *wat* can be assumed to bind a degree variable Δ of the manner adverb *hard*. Note in passing that it is not likely that Δ stands for a *wh*-trace of exclamative *wat* in this example given that degree adverbs normally cannot be extracted from pre-adjectival position by *wh*-movement. The (b)-examples illustrate this for the degree adverb *hoe* by showing that this *wh*-element obligatorily pied-pipes the full AP.

- (385) a. Wat<sub>i</sub> heb jij vandaag [<sub>AP</sub> Δ<sub>i</sub> hard] gewerkt! [wh-exclamative]  
 what have you today hard worked  
 ‘Boy, have you worked hard today!’
- b. \*Hoe<sub>i</sub> heb jij vandaag [<sub>AP</sub> t<sub>i</sub> hard] gewerkt? [wh-interrogative]  
 how have you today hard worked
- b’. [<sub>AP</sub> Hoe hard]<sub>i</sub> heb jij vandaag t<sub>i</sub> gewerkt?  
 how hard have you today worked  
 ‘How hard did you work today?’

That *wh*-movement is not involved in the derivation of the type of *wh*-exclamatives under discussion is also clear from the fact illustrated in (386a) that *wat* can bind a

degree variable embedded in an attributive modifier of a noun phrase. The (b)-examples show that *wh*-movement of the degree modifier *hoe* again gives rise to an unacceptable result in questions, as does, in fact, *wh*-movement of the full attributively used AP; the only option is movement of the full noun phrase, in (386a'').

- (386) a. Wat<sub>i</sub> is dat [NP een [AP Δ<sub>i</sub> mooi] boek]!  
 what is that a beautiful book  
 'What a beautiful book that is!'
- b. \*Hoe<sub>i</sub> is dat [NP een [AP t<sub>i</sub> mooi] boek]?  
 how is that a beautiful book
- b'. \*[AP Hoe mooi]<sub>i</sub> is dat [NP een t<sub>i</sub> boek]?  
 how beautiful is that a book
- b''. [NP een [AP hoe mooi] boek]<sub>i</sub> is dat t<sub>i</sub>?  
 a how beautiful book is that  
 'How beautiful a book is that?'

Subsection II will provide more evidence for assuming that the derivation of examples like (384a), (385a) and (386a) does not involve *wh*-movement, but for the moment we will simply assume that exclamative *wat* is base-generated in clause-initial position in suchlike examples. Furthermore, we assume that exclamative *wat* requires a degree variable to be present in order to be licit. This requirement can be made to follow from a generally accepted economy constraint on natural language that states that an operator is only licit if it actually binds a variable: if an operator does not bind a variable, it is superfluous and should be omitted. This BAN ON VACUOUS QUANTIFICATION is also empirically motivated, as it provides a simple account for the acceptability contrast between the two examples in (387), taken from Krijgsman (1983). Under the plausible assumption that the phonetically empty degree variable Δ can only occur with gradable adjectives, exclamative *wat* can be licensed by a gradable adjective such as *groot* 'big' but not by a non-gradable adjective such as *houten* 'wooden'. Note that the number sign indicates that (387b) is marginally acceptable if *wat* is associated with some contextually determined gradable property that is left implicit with, e.g., the meaning "impressive", an option also found in the fully acceptable sentence *Wat is dat een huis!* 'What an impressive house that is!'.

- (387) a. Wat<sub>i</sub> is dat [een [AP Δ<sub>i</sub> groot] huis]!  
 what is that a big house  
 'What a big house that is!'
- b. #Wat<sub>i</sub> is dat [een [AP houten] huis]!  
 what is that a wooden house

The ban on vacuous quantification may also account for the acceptability contrast between (388a) and (388b); the fact that (388a) is fully acceptable is due to the fact that the degree modifier *erg* is gradable itself, as shown by *[[heel erg] mooi]*, while the degraded status of (388b) is due to the fact that *zeer* is not gradable, as shown by *\*[[heel zeer] mooi]*; cf. Krijgsman (1983). The same can perhaps be said for comparative forms such as *mooier* 'more beautiful' in (388c), as these cannot be

modified by degree adverbs like *heel* either (cf. \**heel mooier*), although this raises the potential problem that comparatives do allow modification by quantifiers like *veel* ‘much’ (cf. *veel mooier* ‘much more beautiful’); we leave this problem to future research.

- (388) a. Wat<sub>i</sub> is dat [<sub>NP</sub> een [<sub>AP</sub> [<sub>Δ<sub>i</sub></sub> erg] mooi] boek]!  
 what is that a very beautiful book  
 ‘What a very beautiful book that is!’  
 b. \*Wat is dat [<sub>NP</sub> een [<sub>AP</sub> zeer mooi] boek]!  
 what is that a very beautiful book  
 c. \*Wat is dat een [<sub>NP</sub> een mooier boek]!  
 what is that a more.beautiful book

The acceptability contrast between (389a) and (389b) also follows from the ban on vacuous quantification: example (389a) is acceptable because exclamative *wat* is properly binding a degree variable associated with the gradable quantifier *veel* in (389a), while (389b) is unacceptable because cardinal numbers are not gradable and thus cannot introduce a degree variable. Example (389c) is unacceptable for the same reason: a definite noun phrase like *het antwoord* ‘the answer’ does not contain a degree variable.

- (389) a. Wat<sub>i</sub> weet jij [<sub>NP</sub> [<sub>Δ<sub>i</sub></sub> veel] dingen]!  
 what know you many things  
 ‘How much you know!’  
 b. \*Wat weet jij [<sub>NP</sub> [een miljoen] dingen]!  
 what know you a million things  
 c. \*Wat weet jij het antwoord!  
 what know you the answer

The fact that we can easily account for the acceptability judgments in (387) to (389) by means of the ban on vacuous quantification provides strong support for the hypothesis that *wh*-elements in *wh*-exclamatives function as operators that must bind a phonetically empty degree variable.

### B. The extremely-large-quantity reading

The extremely-high-degree reading discussed in Subsection A is not the only reading found with *wh*-exclamatives: if the *wh*-element in clause-initial position is associated with a certain type of noun phrase, an extremely-large-quantity reading may also arise; a prototypical example is (390a). The examples in (390b&c) show that the noun phrase must satisfy certain criteria in order for the extremely-large-quantity reading to be possible: a count noun such as *boek* ‘book’ must be plural and the noun phrase must contain the spurious indefinite article *een*; the notion “spurious” is used here because the indefinite article *een* normally cannot be used in plural noun phrases; see N5.1.

- (390) a. Wat heb jij een boeken!  
 what have you a books  
 ‘What a lot of books you have!’  
 b. #Wat heb jij een boek!  
 what have you a book  
 c. \*Wat heb jij boeken!  
 what have you books

The number sign in (390b) indicates that this example is at least marginally acceptable with an extremely-high-degree reading, in which case *wat* is associated with some contextually determined gradable property that is left implicit, such as “impressive”; the same in fact holds for (390a), which is therefore ambiguous; see Subsection C for more examples of such ambiguities.

A non-count noun like *water* ‘water’ is also compatible with an extremely-large-quantity reading: it appears in the singular (as it does not have a plural form), but must again be preceded by the spurious indefinite article *een*, as is clear from the fact that example (391b) is unacceptable.

- (391) a. Wat ligt daar een water!  
 what lies there a water  
 ‘So much water over there!’  
 b. \*Wat ligt daar water!  
 what lies there water

If Zanutinni & Portner (2003) are correct in assuming that exclamative *wh*-phrases are operators that must bind some variable, the acceptability contrasts in (390) and (391) strongly suggests that the spurious article *een* is able to introduce a variable ranging over quantities; see Bennis (1998) for a similar conclusion.

### C. Ambiguity

Plural noun phrases such as (392a), which contain both a gradable attributively used adjective and the spurious article *een*, are ambiguous between an extremely-high-degree and an extremely-large-quantity reading. If we omit the spurious article, as in (392b), the extremely-large-quantity reading becomes unavailable. If we omit the gradable adjective, as in (392c), the extremely-large-quantity reading becomes the most prominent one (although an extremely-high-degree reading remains at least marginally possible with respect with some contextually determined gradable property that is left implicit). If we omit both the spurious article and the gradable adjective, the result is unacceptable.

- (392) a. Wat heeft Jan [<sub>NP</sub> een mooie boeken]! [ambiguous]  
 what has Jan a beautiful books  
 ‘What (a lot of) beautiful books Jan has!’  
 b. Wat heeft Jan [<sub>NP</sub> mooie boeken]! [extremely high degree]  
 what has Jan beautiful books  
 ‘What beautiful books Jan has!’



- c. Wat heeft Jan [<sub>NP</sub> een boeken]! [extremely large quantity]  
 what has Jan a books  
 ‘What a lot of books Jan has!’
- d. \*Wat heeft Jan [<sub>NP</sub> boeken]! [uninterpretable]  
 what has Jan books

The interpretations and judgments above are all expected if the spurious indefinite article *een* and gradable adjectives are able to introduce a degree variable that can be bound by the exclamative operator *wat*. However, if the spurious article *een* and the gradable adjective *mooi* in (392) are indeed both able to introduce a degree variable, we expect example (392a) to simultaneously express the extremely-high-degree and the extremely-large-quantity reading, given that Subsection IIB will show that exclamative *wat* is able to bind more than one variable. It does seem that example (392a) is capable of expressing these two readings simultaneously, but it is not clear that this is obligatory given that the extremely-high-degree reading is the most prominent and for some speakers even the only possible one. If the extremely-large-quantity reading is optional, we may have to conclude that spurious *een* has some other function in addition to the introduction of a quantity variable; we leave this issue for future research.

#### D. Factivity

Since Elliott (1974) and Grimshaw (1979) it has generally been accepted that exclamatives are factive in the sense of Kiparsky & Kiparsky (1970) that the speaker presupposes the truth of the proposition expressed by the utterance. So, a speaker uttering the exclamative in (384a), repeated here as the first part of (393), presupposes that the addressee did work today. This is clear from the fact that this utterance cannot felicitously be followed by the question given as the second part of (393), as it questions the truth of the presupposed proposition. We indicated this by means of the dollar sign.

- (393) Wat<sub>i</sub> heb jij vandaag gewerkt! <sup>\$</sup>Of heb je vandaag niet gewerkt?  
 what have you today worked or have you today not worked  
 ‘How you have worked today! Or didn’t you work today?’

Exclamations crucially differ in this respect from questions. This is clear from the examples in (394). While the exclamation in (394a) cannot be followed felicitously by the question *Of heb je geen boeken gekocht?* because it questions the truth of the presupposed proposition, the question in (394b) can readily be followed by it; this shows that the speaker does not presuppose that the addressee has bought books by uttering the question *Welke boeken heb je gekocht?*

- (394) a. Wat heb jij een boeken gekocht! <sup>\$</sup>Of heb je geen boeken gekocht?  
 what have you a books bought or have you no books bought  
 ‘How many books you have bought! Or haven’t you bought any books?’
- b. Welke boeken heb je gekocht? Of heb je geen boeken gekocht?  
 which books have you bought or have you no books bought  
 ‘Which books did you buy? Or haven’t you bought any books?’

Elliott and Grimshaw further support the claim that exclamatives are factive by showing that they cannot be selected by non-factive verbs; while we do find exclamative clauses as complements of the factive verb *weten* ‘to know’, such clauses do not occur as complements of the non-factive verb *beweren* ‘to contend’.

- (395) a. Marie weet [wat een mooie boeken Peter heeft].  
 Marie knows what a beautiful books Peter has  
 ‘Marie knows what beautiful books Peter has.’  
 b. \*Marie beweert [wat een mooie boeken Peter heeft].  
 Marie contends what a beautiful books Peter has

That the speaker presupposes the truth of the proposition expressed by the embedded exclamative is also clear from the acceptability contrast indicated in (396): cf. Grimshaw (1979:283). Because the speaker presupposes the truth of the proposition expressed by the exclamative, the use of the first person pronoun leads to an incoherent result in (396b) as the speaker cannot deny to have knowledge about the truth of a proposition that he is presupposing to be true. Example (396a), on the other hand, is coherent; the speaker can easily deny that Marie has knowledge about the truth of a proposition that he is presupposing to be true.

- (396) a. Marie weet niet [wat een mooie boeken Peter heeft].  
 Marie knows not what a beautiful books Peter has  
 ‘Marie doesn’t know what beautiful books Peter has.’  
 b. <sup>s</sup>Ik weet niet [wat een mooie boeken Peter heeft].  
 I know not what a beautiful books Peter has  
 ‘I do not know what a beautiful books Peter has.’

### E. Widening

Subsections A through C have shown that *wh*-exclamatives prototypically express an extremely-high-degree or an extremely-large-quantity reading. Other notions often used in describing the interpretation of exclamatives include “surprise”, “unexpectedness”, “emotional reaction” and “noteworthiness”. Now consider the *wh*-exclamatives in (397), which are used to express that the book under discussion is very expensive and thus seem to imply the truth of the propositions expressed by the declarative clauses in the primed examples.

- |   |   |
|---|---|
| (397) a. Wat is dat boek duur!<br>what is that book expensive<br>‘How expensive that book is!’    | a'. Dat boek is zeer duur.<br>that book is very expensive<br>‘That book is very expensive.’         |
| b. Wat is dat een duur boek!<br>what is that an expensive book<br>‘How expensive a book that is!’ | b'. Dat is een zeer duur boek.<br>that is a very expensive book<br>‘That is a very expensive book.’ |

It would be wrong, however, to conclude that the primeless and primed sentences are equivalent, as there are many cases in which speakers could easily use the primed examples without necessarily being able to use the primeless examples. To present-day standards, for instance, a hardcover 300 page book that costs 100 euro’s would normally be called very expensive, so that any speaker could easily use the primed examples in (397) to discuss such a book. A speaker who opens the book

and finds out that the book is written by a popular, best-selling novelist would probably also be able to use exclaimatives like (397a&b). On the other hand, a linguist who knows that the book is on linguistics would probably not use these exclaimatives since he knows that many scientific publishers ask twice as much for similar publications. This shows that the *expectation* of the speaker is a decisive factor in determining the appropriateness of the use of *wh*-exclaimatives.

Zanutinni & Portner (2003) claim that the notions mentioned above are not basic and are actually pragmatic implicatures derived from the two core properties of *wh*-exclaimatives we have already discussed in the previous subsections. First, such exclaimatives are constructions in which an operator binds a degree/quantity variable and thus denote a set of alternative propositions that differ in degree or quantity. Second, *wh*-exclaimatives are factive; the speaker presupposes the truth of the proposition expressed by the non-*wh*-part of the exclamation.

Zanutinni & Portner's claim that the notions normally used to characterize the interpretation of *wh*-exclaimatives are pragmatic implicatures is based on a particular view on discourse semantics. In any conversation, there is a set of propositions that the speaker and addressee equally hold true, the so-called COMMON GROUND. For a sentence to be successfully asserted, the proposition it contains must be added to the common ground. Because the truth of the proposition expressed by the non-*wh*-part of a *wh*-exclaimative is already presupposed, such exclaimatives are less useful for assertion. Because every utterance must have some function, *wh*-exclaimatives must have a function –other than assertion– that is compatible with their factivity; Zanutinni & Portner propose that this function is affecting, or more specifically, WIDENING the common ground.

We will explain the notion of widening on the basis of the examples in (398). Assume that the common ground includes a height scale applicable to adult humans, which ranges from 1.70 to 1.90 meter. The assertion expressed by (398a) would establish that Jan occupies a high position on this scale. Zanutinni & Portner claim that the *wh*-exclaimative in (398b) *widens* this scale and locates Jan on the *extended part* of it; this derives the extremely-high-degree reading discussed in Subsection A. Note in passing that we might also expect an extremely-low-degree reading of (398b) to arise, but this can be excluded by Grice's (1975) Maxim of Quantity because the use of *groot* 'tall' will be blocked for expressing this reading by its more informative antonym, *klein* 'short'.

- |          |               |                    |                 |                       |
|----------|---------------|--------------------|-----------------|-----------------------|
| (398) a. | Jan is groot. | a'.                | Peter is klein. |                       |
|          | Jan is tall   |                    | Peter is short  |                       |
|          | b.            | Wat is Jan groot!  | b'.             | Wat is Peter klein!   |
|          |               | what is Jan tall   |                 | what is Peter short   |
|          |               | 'How tall Jan is!' |                 | 'How short Peter is!' |

Although Zanutinni & Portner do not discuss this, it seems that their reasoning does not necessarily lead to an extremely-high-degree reading of exclaimatives; what is predicted is simply a *higher-than-expected*-degree reading, and it seems that this is correct. Suppose Jan has a garden that needs intensive watering. In order to save drinking water, he has installed a 2000 liter water tank fed by rainwater. After a modest shower he inspects the contents of the tank and finds that it is already half

full. Since this is much more than he had expected, he can easily express his surprise by using the exclamative in (399a); the crucial point is that we are not dealing with an extremely high degree, but simply with a higher-than-expected degree. After the water tank has been completely filled, there is a drought. Jan starts watering the garden and after two weeks he peeks into the water tank, and to his surprise the tank is still half full. Since this is much more than he had expected, he can readily express his surprise by using the exclamative in (399b); the crucial point is again that we are not dealing with an extremely high degree, but with a higher-than-expected degree. For the use of *al* ‘already’ and *nog* ‘still’ in these examples, we refer the reader to Sections A3.2.2, A3.2.3, and A3.3.1.

- (399) a. Wat is de waterbak al vol!  
 what is the water.tank already full  
 ‘How full the water tank already is!’  
 b. Wat is de waterbak nog vol!  
 what is the water.tank still full  
 ‘How full the water tank still is!’

The examples in (399), which were inspired by a similar example provided by Castroviejo (2006), which was also cited in Villalba (2008), clearly show that the extremely-high-degree reading prototypically found in *wh*-exclamatives is not an inherent part of the meaning of *wh*-exclamatives. This reading is pragmatically derived from the more semantic basic properties of exclamatives, as is clear from the fact that it arises under the proper *contextual* circumstances only.

## II. Two syntactic types of *wh*-exclamative

*Wh*-exclamatives come in two different forms; the exclamative *wh*-phrase can be part of a larger phrase that occupies the clause-initial position or it can occupy this position on its own. This was already illustrated in example (382); more examples are given in (400). For reasons that will become clear shortly, we will refer to the (a)-examples as the non-split pattern and to the (b)-examples as the pseudo-split pattern.

- (400) a. Wat snel is die auto!            a'. Wat een snelle auto heb jij!  
 what fast is that car                what a fast car            have you  
 ‘How fast that car is!’                ‘What a fast car you have!’  
 b. Wat is die auto snel!            '. Wat heb jij een snelle auto!  
 what is that car fast                what have you a fast car  
 ‘How fast that car is!’                ‘What a fast car you have!’

The main question in this subsection will be whether or not *wh*-movement is involved in the derivation of the *wh*-exclamatives in (400). In order to establish this, we should show that the two constructions exhibit at least the three characteristic properties of *wh*-movement listed in (401).

- (401) a. There is an obligatory interpretative gap, viz., the trace left by *wh*-movement.  
 b. The antecedent-trace relation can be non-local in °bridge-verb contexts.  
 c. The antecedent-trace relation is island-sensitive.

Our survey will lead to the conclusion that the non-split pattern in the (a)-examples does involve *wh*-movement of the phrase containing the *wh*-element *wat* into clause-initial position, whereas the *wh*-element *wat* in the pseudo-split pattern in the (b)-examples is base-generated in clause-initial position. The latter claim motivates the use of the notion pseudo-split pattern for the (b)-examples in (400), as these do not involve actual splitting of a larger phrase by *wh*-movement. Subsection A and B successively discuss the non-split and the pseudo-split pattern.

#### A. Non-split pattern

Non-split exclamative *wh*-phrases may perform several syntactic functions. The examples in (402) show that they can easily be used as arguments and predicates; the *wh*-phrases are related to an interpretive gap within the clause with the function of, respectively, subject, direct object and complementive. Because this shows that non-split *wh*-exclamative constructions exhibit the characteristic property of *wh*-movement in (401a), we indicate the interpretive gap by means of a trace. The remainder of this subsection will show that this is fully justified as the non-split pattern also exhibits the other characteristic properties of *wh*-movement in (401b&c).

- (402) a. [Wat een mooie boeken]<sub>i</sub> staan er *t*<sub>i</sub> in die kast! [subject]  
 what a beautiful books stand there in that bookcase  
 ‘What beautiful books there are in that bookcase!’
- b. [Wat een mooie boeken]<sub>i</sub> heb je *t*<sub>i</sub> gekocht! [direct object]  
 what a beautiful books have you bought  
 ‘What beautiful books you have bought!’
- c. [Wat mooi]<sub>i</sub> zijn die boeken *t*<sub>i</sub>! [complementive]  
 what beautiful are those books  
 ‘How beautiful those books are!’

The *wh*-movements indicated in (402) are obligatory; the unacceptability of the examples in (403) shows that leaving the *wh*-phrase in the position indicated by the trace results in ungrammaticality. The number sign in (403c) indicates that this example is acceptable without an exclamative intonation if *wat* is interpreted as an intensifier with the meaning ‘quite’; we will ignore this reading here. It should further be noted that, for unknown reasons, example (403c) improves considerably if the particle *maar* is added: *Die boeken zijn maar wat mooi!* We leave this issue for further research.

- (403) a. \*Er staan [wat een mooie boeken] in die kast!  
 there stand what a beautiful books in that bookcase
- b. \*Je hebt [wat een mooie boeken] gekocht!  
 you have what a beautiful books bought
- c. #Die boeken zijn wat mooi!  
 those books are what beautiful

The obligatoriness of *wh*-movement follows if we assume that exclamative *wat* must be moved into clause-initial position in order to create an exclamative operator-variable configuration; see the discussion in Subsection I. As the initial position of a clause can be occupied by a single constituent only, we should also

conclude that exclamative *wat* can be part of a larger phrase and is able to pied-pipe this larger phrase under *wh*-movement. That pied piping is common in non-split *wh*-exclamatives can also be illustrated by means of the examples in (404) in which exclamative *wat* is more deeply embedded in a prepositional object/complementive: *wh*-movement of *wat* triggers movement of the full PP.

- (404) a. [Over *wat* een rare onderwerpen]<sub>i</sub> schrijft hij toch *t*<sub>i</sub>! [PP-complement]  
 about what a strange topics writes he PRT  
 ‘What strange topics he writes about!’  
 b. [Op *wat* een grote stoel]<sub>i</sub> zit jij *t*<sub>i</sub>! [PP-complementive]  
 on what a big chair sit you  
 ‘What a big chair you are sitting in!’

Pied piping also occurs if exclamative *wat* is part of an adverbial phrase. This is illustrated in (405) by means of, respectively, an adjectival and prepositional adverbial phrase of manner.

- (405) a. [Wat zorgvuldig]<sub>i</sub> heb jij *t*<sub>i</sub> gewerkt!  
 what carefully have you worked  
 ‘How meticulously you have worked!’  
 b. [Met *wat* een grote zorgvuldigheid]<sub>i</sub> heb jij *t*<sub>i</sub> gewerkt!  
 with what a great care have you worked  
 ‘With what a great care you have worked!’

The examples in (404) and (405) again illustrate that non-split *wh*-exclamatives exhibit the characteristic property of *wh*-movement in (401a): the *wh*-phrase in clause-initial position is the antecedent of an interpretative gap within the clause with various functions: argument, complementive and adverbial.

Let us now continue with property (401b), according to which the antecedent-trace relation can be non-local in bridge-verb contexts. Extraction of an exclamative *wh*-phrase from an embedded clause always gives rise to a somewhat marked result, but there seems to be a consensus that it is possible if the matrix clause is headed by a bridge verb such as *zeggen* ‘to say’; cf. Krijgsman (1983:132), Corver (1990:ch.4) and Bennis (1998).

- (406) a. <sup>(?)</sup>[*Wat* een mooie boeken]<sub>i</sub> zei hij [dat er *t*<sub>i</sub> in die kast staan]! [subject]  
 what a beautiful books said he that there in that bookcase stand  
 ‘What beautiful books he said are in that bookcase!’  
 b. <sup>(?)</sup>[*Wat* een mooie boeken]<sub>i</sub> zei hij [dat je *t*<sub>i</sub> gekocht hebt]! [direct object]  
 what a beautiful books said he that you bought have  
 ‘What beautiful books he said you have bought!’  
 c. <sup>(?)</sup>[*Wat* mooi]<sub>i</sub> zei hij [dat die boeken *t*<sub>i</sub> zijn]! [complementive]  
 what beautiful said he that those books are  
 ‘How beautiful he said those books are!’

That the examples in (406) are indeed relatively good becomes especially clear when we compare them to the examples in (407) in which the matrix clause is headed by the factive, non-bridge verb *betreuren* ‘to regret’. In order to make the interpretation of these examples more plausible, we have replaced the adjective *mooi* ‘beautiful’ by the adjective *saai* ‘boring’, but the results are still infelicitous.

We conclude from the contrast between the two sets of examples in (406) and (407) that non-split *wh*-exclamatives exhibit property (401b): the antecedent-trace relation can be non-local in bridge-verb contexts.

- (407) a. \*[Wat een saaie boeken]<sub>i</sub> betreurde hij [dat er  $t_i$  in die kast staan]!  
 what a boring books regretted he that there in that bookcase stand  
 b. \*[Wat een saaie boeken]<sub>i</sub> betreurde hij [dat je  $t_i$  gekocht hebt]!  
 what a boring books regretted he that you bought have  
 c. \*[Wat saai]<sub>i</sub> betreurde hij [dat die boeken  $t_i$  zijn]!  
 what boring regretted he that those books are

Finally, we show that non-split *wh*-exclamatives are sensitive to islands. First, the examples in (408) show that exclamative *wh*-phrases cannot be extracted from interrogative clauses.

- (408) a. \*[Wat een mooie boeken]<sub>i</sub> vroeg hij [of er  $t_i$  in die kast staan]!  
 what a beautiful books asked he if there in that bookcase stand  
 b. \*[Wat een mooie boeken]<sub>i</sub> vroeg hij [of je  $t_i$  gekocht hebt]!  
 what a beautiful books asked he if you bought have  
 c. \*[Wat mooi]<sub>i</sub> vroeg hij [of die boeken  $t_i$  zijn]!  
 what beautiful asked he whether those books are

Krijgsman (1983) shows that non-split *wh*-exclamatives are also sensitive to complex noun phrase configurations: example (409b) illustrates that it is impossible to extract an exclamative *wh*-phrase from a relative clause.

- (409) a. Jan verdedigde [de stelling [dat kernenergie zeer gevaarlijk is]].  
 Jan defended the thesis that nuclear.energy very dangerous is  
 'Jan defended the claim that nuclear energy is very dangerous.'  
 b. \*[Wat gevaarlijk]<sub>i</sub> verdedigde Jan [de stelling [dat kernenergie  $t_i$  is]]!  
 what dangerous defended Jan the thesis that nuclear.energy is

The examples in (408) and (409) thus show that non-split *wh*-exclamatives also exhibit the third, and final, characteristic property of *wh*-movement in (401c): the island-sensitivity of the antecedent-trace relation. It is therefore safe to conclude that *wh*-movement is involved in the derivation of non-split *wh*-exclamatives.

### B. Pseudo-split pattern

Now that we have established that the non-split pattern is derived by *wh*-movement, our next task is to show that the pseudo-split pattern does not involve *wh*-movement. Consider example (410), which provides the pseudo-split counterparts of the non-split *wh*-exclamatives in (402).

- (410) a. Wat staan er een mooie boeken in die kast! [subject]  
 what stand there a beautiful books in that bookcase  
 'What beautiful books are in that bookcase?'  
 b. Wat heb je een mooie boeken gekocht! [direct object]  
 what have you a beautiful books bought  
 'What beautiful books you have bought!'



- c. Wat zijn die boeken mooi! [complementive]  
 what are those books beautiful  
 ‘How beautiful those books are!’

The previous subsection has argued that the *wh*-phrases in clause-initial position in the non-split exclamatives in (402) are constituents, and a conceivable analysis of the split exclamatives in (410) would therefore be that *wh*-movement of exclamative *wat* doesn’t have to pied-pipe the remainder of the larger constituent but may also strand it. This would give rise to the representations in (411), with *t* representing the *wh*-trace of exclamative *wat*.

- (411) • Incorrect analysis of the pseudo-split *wh*-exclamatives in (410)  
 a. Wat<sub>i</sub> staan er [<sub>t<sub>i</sub></sub> een mooie boeken] in die kast!  
 b. Wat<sub>i</sub> heb je [<sub>t<sub>i</sub></sub> een mooie boeken] gekocht!  
 c. Wat<sub>i</sub> zijn die boeken [<sub>t<sub>i</sub></sub> mooi]!

The discussion below will show, however, that this analysis is not tenable: *wh*-movement cannot be involved in the derivation of the pseudo-split pattern. Instead, we will be led to assume that exclamative *wat* is base-generated in clause-initial position and that it enters into a °syntactic dependency relation with a degree variable introduced by the gradable adjective *mooi* ‘beautiful’ (in the present examples that receive a higher-than-expected-degree reading). The correct analysis of the examples in (410) is therefore the one sketched in (412), in which  $\Delta$  stands for the degree variable and the indices indicate the syntactic dependency relation between exclamative *wat* and the variable.

- (412) • Correct analysis of the pseudo-split *wh*-exclamatives in (410)  
 a. Wat<sub>i</sub> staan er [een [ $\Delta$ <sub>i</sub> mooie] boeken] in die kast!  
 b. Wat<sub>i</sub> heb je [een [ $\Delta$ <sub>i</sub> mooie] boeken] gekocht!  
 c. Wat<sub>i</sub> zijn die boeken [ $\Delta$ <sub>i</sub> mooi]!

The two analyses cannot easily be evaluated on the basis of the examples in (410), as they give rise to more or less similar, since *wh*-extraction is possible from interrogative *wat voor*-phrases functioning as subject or object. Evaluation is possible, however, on the basis of the pseudo-split counterparts of the non-split *wh*-exclamative in (404), in which exclamative *wat* is embedded in a PP. The primeless examples in (413) show that the pseudo-split counterparts of these examples are fully acceptable. The *wh*-movement analysis would assign to these examples the structures in the singly-primed examples, while the alternative hypothesis according to which exclamative *wat* is base-generated in clause-initial position is given in the doubly-primed examples.

- (413) a. Wat schrijft hij toch over een rare onderwerpen! [PP-complement]  
 what writes he PRT about a strange topics  
 ‘What strange topics he writes about!’  
 a’. Wat<sub>i</sub> schrijft hij toch [<sub>PP</sub> over [<sub>NP</sub> <sub>t<sub>i</sub></sub> een rare onderwerpen]]!  
 a’’. Wat<sub>i</sub> schrijft hij toch [<sub>PP</sub> over [<sub>NP</sub> een [<sub>AP</sub>  $\Delta$ <sub>i</sub> rare] onderwerpen]]!

- b. Wat zit jij op een grote stoel! [PP-complementive]  
 what sit you on a big chair  
 'What a big chair you are sitting in!'
- b'. Wat<sub>i</sub> zit jij [PP op [NP t<sub>i</sub> een grote stoel]]!  
 b''. Wat<sub>i</sub> zit jij [PP op [NP een [AP Δ<sub>i</sub> grote] stoel]]!

What we will show now is that the syntactic representations in (413a'&b') are syntactically ill-formed, which leaves us with the structures in the doubly-primed examples. We will do so with the help of a brief discussion of so-called *wat voor*-phrases, which are used to form questions and arguably do involve *wh*-movement. The examples in (414) show that such *wat voor*-phrases at first sight behave exactly like *wh*-exclamatives in that they optionally split in certain cases; the reader can verify this by comparing the examples in (414) to the *wh*-exclamatives in (402a&b) and (410a&b).

- (414) a. [Wat voor een boeken]<sub>i</sub> staan er t<sub>i</sub> in die kast? [subject]  
 what for a books stand there in that bookcase  
 'What kind of books are there in that bookcase?'
- a'. Wat<sub>i</sub> staan er [t<sub>i</sub> voor een boeken] in die kast?  
 what stand there for a books in that bookcase  
 'What kind of books are there in that bookcase?'
- b. [Wat voor een boeken]<sub>i</sub> heb je t<sub>i</sub> gekocht? [direct object]  
 what for a books have you bought  
 'What kind of books have you bought?'
- b'. Wat<sub>i</sub> heb je [t<sub>i</sub> voor een boeken] gekocht?  
 what have you for a books bought  
 'What kind of books have you bought?'

However, *wat voor*-constructions exhibit a crucially different behavior from *wh*-exclamative phrases in that the split pattern is impossible if the *wat voor*-phrase is the complement of a preposition. It is important to note that the impossibility of the split pattern is in conformity with the fact that *wh*-movement from prepositional phrases is normally excluded, the only exception being *wh*-movement from pronominalized PPs of the form *waar* + P 'P + what'.

- (415) a. [Over wat voor een onderwerpen]<sub>i</sub> schrijft hij t<sub>i</sub>? [PP-complement]  
 about what for a topics writeS he  
 'About what kind of topics is he writing?'
- a'. \*Wat<sub>i</sub> schrijft hij [PP over [NP t<sub>i</sub> voor een onderwerpen]]?  
 what writes he about for a topics
- b. [PP Op wat voor een stoel] zit jij t<sub>i</sub>? [PP-complementive]  
 on what for a chair sit you  
 'In what kind of chair are you sitting?'
- b'. \*Wat<sub>i</sub> zit jij [PP op [NP t<sub>i</sub> voor een stoel]]?  
 what sit you on for a chair

In short, the fact that the primed examples are unacceptable shows that Dutch prepositional phrases do not only constitute islands for *wh*-extraction of their

nominal complements but also for subparts of their nominal complement. Now that we have established this, we can return to the pseudo-split *wh*-exclamatives in (413). The fact that the two singly-primed structures derived by *wh*-movement are in all relevant respects identical to the unacceptable primed examples in (415) shows that they are syntactically ill-formed. We should therefore conclude that the postulation of a *wh*-trace was incorrect and that the alternative analysis in the doubly primed examples in (413), according to which exclamative *wat* binds the degree variable introduced by the gradable adjective, is to be preferred.

A similar argument can be built on the basis of the pseudo-split counterparts of the adverbial *wh*-phrases in (405), which are given in (416); the *wh*-movement hypothesis assigns to these constructions the representations in the singly-primed examples while the alternative hypothesis provides the structures in the doubly-primed examples. Because the earlier discussion of the examples in (413) to (415) has already shown that representation (416b') is syntactically ill-formed, we will focus on the exclamative in (416a).

- (416) a. Wat heb jij zorgvuldig gewerkt!  
           what have you carefully worked  
           ‘How meticulously you have worked!’  
    a'. Wat<sub>i</sub> heb jij [<sub>AP</sub> t<sub>i</sub> zorgvuldig] gewerkt!  
    a''. Wat<sub>i</sub> heb jij [<sub>AP</sub> Δ<sub>i</sub> zorgvuldig] gewerkt!  
    b. Wat heb jij met een grote zorgvuldigheid gewerkt!  
           what have you with a great care worked  
           ‘With what a great care you have worked!’  
    b'. Wat<sub>i</sub> heb jij [<sub>PP</sub> met [<sub>NP</sub> t<sub>i</sub> een grote zorgvuldigheid]] gewerkt!  
    b''. Wat<sub>i</sub> heb jij [<sub>PP</sub> met [<sub>NP</sub> een [<sub>AP</sub> Δ<sub>i</sub> grote] zorgvuldigheid]] gewerkt!

The reason to exclude analysis (416a') has to do with the fact that it violates another independently motivated restriction on *wh*-movement, viz., that *wh*-movement of degree modifiers such as *hoe* ‘how’ triggers pied piping of the full adverbial phrase of manner; stranding of the non-*wh*-part of the phrase gives rise to a severely degraded result. The fact that the unacceptable structure in (417b) resembles (416a') again disfavors the *wh*-movement analysis.

- (417) a. [<sub>AP</sub> Hoe zorgvuldig]<sub>i</sub> heb jij gewerkt?  
           how carefully have you worked  
           ‘How carefully have you worked?’  
    b. \*Hoe<sub>i</sub> heb je [<sub>AP</sub> t<sub>i</sub> zorgvuldig] gewerkt?  
           how have you carefully worked

The discussion above has shown that pseudo-split exclamative constructions are not sensitive to certain well-established islands for *wh*-movement, and thus do not exhibit the characteristic property of *wh*-movement in (401c). Pseudo-split *wh*-exclamatives do not exhibit the property in (401b) either. The examples in (418) show that the relation between the exclamative element *wat* and its associate (the trace/degree variable cannot be established in a non-local fashion in bridge-verb contexts; cf. Krijgsman (1983:150), Corver (1990:ch.4) and Bennis (1998).

- (418) a. \*Wat zei hij [dat er een mooie boeken in die kast staan]! [subject]  
 what said he that there a beautiful books in that bookcase stand  
 b. \*Wat zei hij [dat Marie een mooie boeken gekocht had]! [direct object]  
 what said he that Marie a beautiful books bought had  
 c. \*Wat zei hij [dat die boeken mooi zijn]! [complementive]  
 what said he that those books beautiful are

The unacceptability of the pseudo-split *wh*-exclamatives in (418) is hard to explain under a *wh*-movement approach. One possibility would be to assume that the unacceptability is related to the fact that *wat* is subextracted from a noun/adjectival phrase. The acceptability of the examples in (419) shows, however, that such subextraction *is* possible in the case of uncontroversial *wh*-constructions involving *wat voor*-phrases; cf. Corver (1990) and Bennis (1998).

- (419) a. Wat<sub>i</sub> zei hij [dat er [t<sub>i</sub> voor een boeken] in die kast staan].  
 what said he that there for a books in that bookcase stand  
 ‘What kind of books said he are in the bookcase?’  
 b. Wat<sub>i</sub> zei hij [dat Marie [t<sub>i</sub> voor een boeken] gekocht had].  
 what said he that Marie for a books bought had  
 ‘What kind of books said he Marie had bought?’

An alternative account for the unacceptability of the examples (418) can be built on the earlier suggestion that exclamative *wat* must enter in a syntactic dependency relation with the degree variable introduced by the gradable adjective *mooi* ‘beautiful’. Given that such syntactic dependencies are normally clause-bound, no relation can be established between the exclamative operator *wat* and the degree variable introduced by the gradable adjective *mooi* ‘beautiful’; the two elements are simply not sufficiently local, as the former is located in the main clause while the latter is located in the embedded clause. Note that the clause-bound nature of the syntactic dependency makes it impossible to test whether the pseudo-split pattern is sensitive to islands evoked by, e.g., embedded interrogative or relative clauses, as these imply that the syntactic dependency crosses a clause boundary: the pseudo-split counterparts of the non-split examples in (407) to (409) are therefore (correctly) predicted to be impossible anyway.

*C. More differences between non-split and pseudo-split wh-exclamatives*

The conclusion that non-split and pseudo-split *wh*-exclamatives have different underlying structures is consistent with the fact that they exhibit different syntactic behavior in other respects as well. The examples in (420), for instance, show that they differ with respect to the presence of spurious *een*: while *een* is obligatorily present in non-split *wh*-exclamatives such as (420a) with a higher-than-expected-degree reading, it can easily be left out in the corresponding pseudo-split counterpart.

- (420) a. [Wat \*(een) mooie boeken]<sub>i</sub> heb jij t<sub>i</sub> gekocht!  
 what a beautiful books have you bought  
 ‘What beautiful books you have bought!’  
 b. Wat<sub>i</sub> heb jij [(een) [Δ<sub>i</sub> mooie] boeken] gekocht!  
 what have you a beautiful books bought  
 ‘What a beautiful books you have bought!’

We have already mentioned in Subsection IC that it is somewhat surprising that spurious *een* can be present in pseudo-split *wh*-exclamatives such as (420b) with a higher-than-expected-degree reading; we expect it to introduce a quantity variable which is not reflected in the meaning. It has been argued, however, that the obligatory presence of spurious *een* in non-split *wh*-exclamatives is not only related to meaning but may also have a syntactic motivation; see Bennis et al. (1998) for discussion. Such an approach to the obligatoriness of spurious *een* in non-split *wh*-exclamatives would be incompatible with the claim that the pseudo-split constructions are derived from the same base structures as their non-split counterparts, given that we would then predict spurious *een* to be obligatory in the pseudo-split pattern as well. The contrast between the two examples in (420) with respect to spurious *een* thus indirectly supports the conclusion that non-split and pseudo-split *wh*-exclamatives have different underlying structures.

The conclusion that pseudo-split *wh*-exclamatives do not involve *wh*-movement may also account for the fact that a single exclamative *wh*-element is able to bind more than one variable; cf. Corver (1990:110). This is illustrated in (421): the presence of the spurious article *een* in the examples in (421a&b) first shows that exclamative *wat* can be associated with either the subject or the object; the relative acceptability of (421c) further shows that *wat* can also be associated with both the subject and the object.

- (421) a. Wat hebben er [*een* mensen] goederen gedoneerd!  
 what have there a people goods donated  
 ‘What a lot of people have donated things!’
- b. Wat heeft Marie [*een* goederen] gedoneerd!  
 what has Marie a goods donated  
 ‘What a lot of things Marie has donated!’
- c. <sup>(?)</sup>Wat hebben er [*een* mensen] [*een* goederen] gedoneerd!  
 what have there a people a goods donated  
 ‘What a lot of people have donated what a lot of things!’

This would be very difficult to account for under a *wh*-movement analysis given that the one-to-many relation in (421c) is not found in the case of uncontroversial *wh*-extraction. We illustrate this by means of questions with the *wat voor* split: although the examples in (422a&b) show that subjects and objects both allow the *wat voor* split, example (422c) shows that *wat* cannot be associated with two *wh*-traces; see Section 11.3.7, sub I, for a more detailed discussion of this restriction.

- (422) a. Wat<sub>i</sub> hebben er [<sub>i</sub> voor een mensen] goederen gedoneerd?  
 what have there for a people goods donated  
 ‘What kind of of people have donated things?’
- b. Wat<sub>i</sub> heeft Marie [<sub>i</sub> voor een goederen] gedoneerd?  
 what has Marie for a goods donated  
 ‘What kind of goods has Marie donated?’
- c. \*Wat<sub>i</sub> hebben er [<sub>i</sub> voor een mensen] [<sub>i</sub> voor een goederen] gedoneerd?  
 what have there for a people for a goods donated  
 ‘What kind of of people have donated what kind of things?’

Note, finally, that while example (423b) is notably better than (422c), example (423b) is much worse than (421c). The contrast between the two examples in (423) would again be surprising if pseudo-split *wh*-exclamatives were derived by *wh*-movement of exclamative *wat*.

- (423) a. \*Wat hebben er [een mensen] [wat een goederen] gedoneerd!  
 what have there a people what a goods donated  
 ‘What a lot of people have donated what a lot of things!’  
 b. Wat<sub>i</sub> hebben er [<sub>t<sub>i</sub></sub> voor een mensen] [wat voor een goederen] gedoneerd?  
 what have there for a people what for a goods donated  
 ‘What kind of people have donated what kind of things?’

### III. *Wh*-exclamatives can be main or non-main clauses

The discussion of *wh*-exclamatives in the previous subsections has focused on exclamative main clauses, that is, we have looked at cases in which the *wh*-phrase occupies the initial position of the main clause. Subsection ID has briefly mentioned, however, that there are also embedded exclamative clauses. This subsection will show that such embedded cases differ from their main clause counterparts in various respects. The first difference is illustrated in (424): while main clauses allow both the non-split and the pseudo-split pattern, embedded exclamatives allow the non-split pattern only.

- (424) a. Ik was vergeten [[wat een aardige vrouw]<sub>i</sub> Marie t<sub>i</sub> is].  
 I was forgotten what a nice woman Marie is  
 ‘I’d forgotten what a nice woman Marie is.’  
 b. \*Ik was vergeten [wat<sub>i</sub> Marie [een [<sub>Δ<sub>i</sub></sub> aardige] vrouw] is].  
 I was forgotten what Marie a nice woman is

The examples in (425) illustrate a second difference: the exclamative *wh*-element *hoe* ‘how’ can sometimes be used in embedded contexts.

- (425) a. Ik was vergeten [[hoe aardig]<sub>i</sub> Marie t<sub>i</sub> is].  
 I was forgotten how nice Marie is  
 ‘I’d forgotten how nice Marie is.’  
 b. \*Ik was vergeten [hoe<sub>i</sub> Marie [<sub>Δ<sub>i</sub></sub> aardig] is].  
 I was forgotten hoe Marie nice is

The examples in (426) show that this option is only available if the preposed *wh*-phrase is adjectival in nature, that is, *hoe* ‘how’ is excluded if the preposed *wh*-phrase is a noun phrase.

- (426) a. Ik was vergeten [[wat/\*hoe een aardige vrouw]<sub>i</sub> Marie t<sub>i</sub> is].  
 I was forgotten what/how a nice woman Marie is  
 ‘I’d forgotten what a nice woman Marie is.’  
 b. Ik was vergeten [[hoe/\*wat aardig]<sub>i</sub> Marie t<sub>i</sub> is].  
 I was forgotten how/what nice Marie is  
 ‘I’d forgotten how nice Marie is.’

The examples in (427) show that embedded *wh*-exclamatives differ in this respect from main clause *wh*-exclamatives, as the use of *hoe* ‘how’ is normally excluded in the latter case; cases like (427b) are normally found in formal language and (older) writing only and considered obsolete.

- (427) a. [Wat/\*Hoe een aardige vrouw]<sub>i</sub> is Marie *t*<sub>i</sub>!  
 what/how a nice woman is Marie  
 ‘What a nice woman Marie is!’
- b. [Wat/#Hoe aardig]<sub>i</sub> is Marie *t*<sub>i</sub>!  
 what/how nice is Marie  
 ‘How kind nice is!’

The fact that *hoe* is only acceptable in embedded clauses such as (426b) may give rise to the idea that there are in fact no embedded *wh*-exclamative constructions; we may be dealing with special uses of embedded *wh*-questions instead given that *hoe* is the designated interrogative element in questions such as (428).

- (428) [Hoe aardig]<sub>i</sub> is Marie *t*<sub>i</sub>?  
 how nice is Marie  
 ‘How nice is Marie?’

The hypothesis that apparent embedded *wh*-exclamative constructions are actually interrogative deserves serious consideration, as certain questions can indeed be used as exclamatives, a typical example being *Wat heb je nu weer gedaan?!* ‘What stupid things have you done now?!’. We will show, however, that this hypothesis runs into several potential problems. First, it leaves unexplained why the main clause counterparts of the embedded clauses with a nominal *wh*-phrase in (429a&b) cannot be used as regular questions: the number signs in the primed examples indicate that such main clauses are acceptable but only as exclamations.

- (429) a. Ik weet [[wat een boeken]<sub>i</sub> hij heeft *t*<sub>i</sub>].  
 I know what a books he has  
 ‘I know what a large quantity of books he has.’
- a'. # [Wat een boeken]<sub>i</sub> heeft hij *t*<sub>i</sub>?  
 what a books has he
- b. Ik weet [[wat een mooie boeken]<sub>i</sub> hij heeft *t*<sub>i</sub>].  
 I know what a beautiful books he has  
 ‘I know what fine books he has.’
- b'. # [Wat een mooie boeken]<sub>i</sub> heeft hij *t*<sub>i</sub>?  
 what a beautiful books has he

That we cannot interpret the primed examples in (429) as questions probably means that we should restrict the prohibition of embedded exclamatives to cases in which the fronted *wh*-phrase is adjectival in nature. While it is actually very difficult to implement this idea, there are also empirical reasons for assuming that it is not on the right track. Elliott (1974) and Grimshaw (1979) have shown, for example, that while interrogative *wh*-elements cannot readily co-occur with degree modifiers, this is easily possible with exclamative *wh*-elements. This is illustrated in (430) for the degree modifier *vreselijk* ‘terribly’: while the question in (430b) is quite marked,



example (430a) is completely natural with a higher-than-expected-degree reading. This contrast would be hard to explain if apparent embedded *wh*-exclamatives were in fact interrogatives.

- (430) a. Ik weet [[hoe vreselijk groot]<sub>i</sub> hij <sub>t<sub>i</sub></sub> is].  
 I know how terribly tall he is  
 'I know how terribly tall is.'  
 b. <sup>s</sup>[Hoe vreselijk groot]<sub>i</sub> is hij <sub>t<sub>i</sub></sub>?  
 how terribly tall is he

Furthermore, there is good reason for assuming that examples such as (431a) are structurally ambiguous. This can be brought out by the fact that Dutch allows overtly realization of the complementizer in constructions like these in speech. The (b)-examples show that the complementizer may be *of* 'whether', which can be seen as a typical quality of embedded interrogative clauses, but can also be *dat* 'that', which is a characteristic of non-interrogative clauses. Although judgments are not fully clear, it seems that the embedded clause in (431b) must indeed be interpreted as interrogative, while the embedded clause in (431b') is preferably interpreted as exclamative (although some speakers also allow an interrogative interpretation).

- (431) a. Ik weet [[hoe groot]<sub>i</sub> hij <sub>t<sub>i</sub></sub> is]. [ambiguous]  
 I know how tall he is  
 'I know how tall he is.'  
 b. Ik weet [[hoe groot]<sub>i</sub> of hij <sub>t<sub>i</sub></sub> is]. [question reading only]  
 I know how tall comp he is  
 'I know how tall he is.'  
 b'. Ik weet [[hoe groot]<sub>i</sub> dat hij <sub>t<sub>i</sub></sub> is]. [exclamative reading preferred]  
 I know how tall comp he is  
 'I know how tall he is.'

Judgments may become clearer for some speakers if we add the degree adverb *vreselijk* 'terribly' to the adjectival phrases in (431). In accordance with the fact illustrated in (430b) that this disfavors the interrogative interpretation, example (432a) receives a higher-than-expected-degree reading and the example with the complementizer *of* in (432b) seems degraded.

- (432) a. Ik weet [[hoe vreselijk groot]<sub>i</sub> hij <sub>t<sub>i</sub></sub> is]. [exclamative reading preferred]  
 I know how terribly tall he is  
 'I know how terribly tall he is.'  
 b. <sup>??</sup>Ik weet [[hoe vreselijk groot]<sub>i</sub> of hij <sub>t<sub>i</sub></sub> is].  
 I know how terribly tall comp he is  
 'I know how terribly tall he is.'  
 b'. Ik weet [[hoe vreselijk groot]<sub>i</sub> dat hij <sub>t<sub>i</sub></sub> is].  
 I know how terribly tall comp he is  
 'I know how terribly tall he is.'

The discussion above has shown that the hypothesis that the presumed embedded exclamative clauses are actually interrogative clauses runs into various problems; we refer the reader to Elliott (1974) and Grimshaw (1979) for more

problems based on English. If we conclude from this that we are dealing with true embedded exclamatives, there are still at least two difficult questions to answer: Why is the pseudo-split pattern excluded in embedded clauses and how is it that the *wh*-element *hoe* ‘how’ can be used in embedded clauses only? We have to leave these issues to future research.

#### *IV. Exclamations versus exclamatives*

The *wh*-constructions discussed in the previous subsections are by no means the only way to form exclamations. In fact, there are many types of exclamations, but it is not the case that all types are of interest for syntactic research. It seems that syntax has very little to say about exclamations that consist of a single word (often interjections) like *goddank!* ‘thank goodness!’, *bah!* ‘yuck!’, *asjemenou!* ‘good heavens’, or lexicalized phrases like *Lieve hemel* ‘good heavens’ or *Mijn god* ‘My God!’, as their use as exclamations is mainly a matter of lexical meaning. According to Castroviejo Miró (2008) exclamations such as those in (433) are not a subject matter of syntax either but of pragmatics; we are dealing with regular declarative expressions that are *used* as exclamations.

- (433) a. Wat vind je van dit schilderij? Dat is fantastisch!  
 what find you of this painting that is great  
 ‘What do you think of this painting? It’s great!’  
 b. Kom je morgen? Ja, ik kijk ernaar uit!  
 come you tomorrow yes I look to.it out  
 ‘Are you coming tomorrow? Yes, I am looking forward to it!’

Another typical example already mentioned in subsection III is the question in (434a), in which the exclamative intonation contour indicates that a special non-interrogative interpretation is intended; this example is used to express a reproach. We are thus dealing with a similar phenomenon as in (434b), in which a question is used as an order. Examples like these belong to the domain of pragmatics that investigates indirect speech acts; we refer the reader to the seminal paper by Searle (1975) and the brief review of speech act theory in Huang (2009).

- (434) a. Wat heb je nu (weer) gedaan?!  
 what have you now PRT done  
 ‘For God’s sake, what have you done now?!’  
 b. Wil je daar alsjebieft mee ophouden?!  
 want you there please with prt.-stop  
 ‘Will you, please, stop doing that?!’

What the cases mentioned so far have in common is their special exclamative intonation contour, which is a clue for the hearer that a certain construction is intended as an exclamation. Syntactic research is more interested in exclamations that have certain special syntactic features; such exclamations are normally referred to as exclamative constructions or EXCLAMATIVES. Next to the *wh*-exclamatives which have been the main interest of our discussion in the previous subsections, there are several other types of exclamative construction, which we will briefly discuss in Subsection A. Subsection B discusses a number of other cases that can be

used as exclamations but which we believe would be more profitably analyzed in terms of the lexicon or language use. For want of in-depth syntactic investigations, the discussion will necessarily be of a preliminary nature.

*A. Other types of exclamative constructions*

Consider again the *wh*-exclamatives in (435). We have seen that these constructions have various characteristic properties. First, they involve the exclamative *wh*-element *wat*, which acts as an exclamative operator. Second, the exclamative operator is licensed by binding a variable introduced by a gradable adjective and/or the spurious article *een*. Third, the operator and the variable enter into a syntactic dependency relation, which means that they must be part of the same clause. The examples in (435) also illustrate that *wh*-exclamatives come in two types: non-split *wh*-exclamatives like the primeless examples, which are derived by *wh*-movement, and pseudo-split *wh*-exclamatives like the primed examples, which involve base-generation of the exclamative operator *wat* in sentence-initial position.

- (435) a. [Wat een mooie boeken]<sub>i</sub> staan er *t<sub>i</sub>* in die kast!  
 what a beautiful books stand there in that bookcase  
 ‘What beautiful books there are in that bookcase!’
- a'. Wat staan er een mooie boeken in die kast!  
 what stand there a beautiful books in that bookcase  
 ‘What beautiful books are in that bookcase!’
- b. [Wat mooi]<sub>i</sub> zijn die boeken *t<sub>i</sub>*!  
 what beautiful are those books  
 ‘How beautiful those books are!’
- b'. Wat zijn die boeken mooi!  
 what are those books beautiful  
 ‘How beautiful those books are!’

The introduction to this subsection has shown that the use of an exclamative intonation pattern is not sufficient for concluding that we are dealing with exclamatives, that is, exclamations that are syntactically marked as such. We must therefore appeal to other properties in order to establish this. Subsection I has shown that *wh*-exclamatives are characterized by the fact that they have a higher-than-expected-degree or a larger-than-expected-quantity reading; we will use this as first distinguishing feature of exclamative constructions. Subsection IA has further shown that the exclamative *wh*-element is not licensed as a clausal constituent but as an exclamative operator; we will consider the presence of this element a second characteristic of exclamative constructions. Similarly, we will consider the presence of spurious article *een* as an important clue, although we must be more careful in this case because it can also occur in other construction types such as the interrogative *wat voor*-construction: cf. *Wat voor een boeken heb je gekocht* ‘What kind of books have you bought?’. From these three criteria we can safely conclude that we are dealing with genuine exclamative constructions in the examples in (436); it seems in fact reasonable to assume that they are derived from the primeless examples in (435) by some form of ellipsis.

- (436) a. Wat een mooie boeken!                      b. Wat mooi!  
           what a beautiful books                      what beautiful  
           ‘What beautiful books!’                      ‘How beautiful!’

Other potential cases of exclamative constructions are given in (437a). These examples have a higher-than-expected-degree or a larger-than-expected-quantity reading; both examples in fact allow the two readings, although we have only indicated the most prominent one within square brackets. The fact that the noun phrases in these examples contain the spurious article *een* can be seen as an additional clue that we are dealing with exclamative constructions. If so, we should raise the question how the degree/quantity variable introduced by the adjective/spurious article is bound. Bennis (1998) has suggested that the ethical dative *me* is like exclamative *wat* in that it can function as an exclamative operator (which would of course be compatible with the fact that the ethical dative always expresses emotional involvement of the speaker). The fact illustrated in the primed examples that the ethical dative blocks the use of exclamative *wat* can be used to support this claim: if the ethical dative is indeed an exclamative operator, the addition of exclamative *wat* is blocked because it leads to vacuous quantification as it is not needed to bind the variable.

- (437) a. Er staan *me* een mooie boeken in die kast!                      [quality]  
           there stand me a beautiful books in that bookcase  
           ‘What beautiful books are in that bookcase!’  
       a'. \*Wat staan er *me* een mooie boeken in die kast!  
           what stand there me a beautiful books in that bookcase  
       b. Er staan *me* een boeken in die kast!                      [quantity]  
           there stand me a books in that bookcase  
           ‘What a lot of books are in that bookcase!’  
       b'. \*Wat staan er *me* een boeken in die kast!  
           what stand there me a books in that bookcase

Bennis also suggests that particles such as *toch* may function as exclamative operators. This would be consistent with the fact that the primeless examples in (438) do have a higher-than-expected-degree/larger-than-expected-quantity reading, but the fact that *toch* does not block the use of exclamative *wat* may be a problem for this claim: if *toch* is indeed an exclamative operator, the addition of exclamative *wat* should be blocked because it would lead to vacuous quantification as it is not needed to bind the variable. In fact, the same problem occurs with *Er staan me toch een (mooie) boeken in die kast!* in which *toch* co-occurs with the ethical dative *me*.

- (438) a. Er staan *toch* een mooie boeken in die kast!                      [quality]  
           there stand PRT a beautiful books in that bookcase  
       a'. Wat staan er *toch* een mooie boeken in die kast!  
           what stand there PRT a beautiful books in that bookcase  
       b. Er staan *toch* een boeken in die kast!                      [quantity]  
           there stand PRT a books in that bookcase  
       b'. Wat staan er *toch* een boeken in die kast!  
           what stand there PRT a books in that bookcase

Bennis solves the problem that the particle *toch* can co-occur with exclamative *wat* and the ethical dative by assuming that *toch* can have other (adverbial) functions next to its use as exclamative operator. It is not a priori clear whether appealing to the presence of *toch* is needed to account for the exclamative higher-than-expected-degree/larger-than-expected-quantity meaning of the primeless examples in (438), given that the examples in (439) also allow an exclamative reading. If we take the presence of the spurious article *een* as sufficient evidence for assuming that we are dealing with exclamatives, we should conclude that the exclamative operator does not have to be phonetically realized.

- (439) a. Er staan een mooie boeken in die kast! [quality]  
 there stand a beautiful books in that bookcase  
 ‘What beautiful books are in that bookcase!’  
 b. Er staan een boeken in die kast! [quantity]  
 there stand a books in that bookcase  
 ‘What a lot of books are in that bookcase!’

Postulating a phonetically empty exclamative operator makes it unnecessary to appeal to the particle *toch* to account for the exclamative reading of the primeless examples in (438), but it also raises the question as to why we need exclamative *wat* or the ethical dative at all. For completeness’ sake, note that the spurious article can also be dropped in the examples in (439). The resulting structure in (440a) has the same higher-than-expected-degree reading as (439a). The resulting structure in (440b), on the other hand, does not allow the larger-than-expected-quantity reading, which is in fact expected on the hypothesis that the quantity variable is introduced by *een*; the higher-than-expected-degree reading that arises instead must be the attributed to some contextually determined gradable property that is left implicit.

- (440) a. Er staan mooie boeken in die kast! [quality]  
 there stand beautiful books in that bookcase  
 b. Er staan boeken in die kast! [quantity]  
 there stand books in that bookcase

Another potential exclamative construction without an overt exclamative operator is given in (441). The fact that (441a) involves the spurious article *een* may again be seen as an argument for assuming that we are dealing with a syntactically marked exclamation. A plausible account of this example would be to assume that the noun phrase *een boeken* undergoes °reconstruction into the object position of the verb *hebben* in the scope of some empty exclamative operator, as a result of which the degree/quantity variable can be properly bound; the details of an analysis of this kind still need to be properly worked out. Although example (441b) does not provide a visible clue in favor of assuming exclamative status, we may assume this by analogy with example (441a).

- (441) a. Een (mooie) boeken dat hij heeft!  
 a beautiful books that he has  
 b. Mooi dat het boek geworden is!  
 beautiful that the book become is

Postulating a covert exclamative operator in the examples in (441) can be supported by the fact that it correctly predicts that use of the exclamative operator *what* is excluded in this construction, as this would lead to vacuous quantification.

- (442) a. \**Wat een (mooie) boeken dat hij heeft!*  
           what a beautiful books that he has  
       b. \**Wat mooi dat het boek geworden is!*  
           what beautiful that the book become is

Note in passing that the clauses following the noun and adjective are introduced by the complementizer *dat* ‘that’; *dat* cannot be analyzed as a relative pronoun given that it would then fail to agree in number with its antecedent; relative pronouns with a plural nominal antecedent surface as *die*, while relative elements with an adjectival antecedent surface as *wat*. This observation will become relevant in the next subsection.

### B. Exclamations

Not all exclamations are instantiations of exclamative constructions, that is, constructions having certain syntactic properties that can be held responsible for an exclamative interpretation. Such interpretations may also be the result of, e.g., lexical or pragmatic considerations. Consider example (443a), which superficially resembles example (441a) from the previous subsection but is in fact of an entirely different nature. First, we are not dealing with a higher-than-expected-degree or larger-than-expected-quantity reading; the speaker instead expresses surprise about the *type* of books that Peter reads. Second, (443a) does not provide any visible clue that we are dealing with an exclamative construction, due to the fact that *een* is not present. Third, we are dealing with a kind of relative construction; *die* in (443a) is a pronoun that agrees in gender and number with its antecedent *boeken*, while we have seen that *dat* in (441a) is a complementizer. Finally, example (443b) shows that (443a) can be used in regular NP-position, while (441a) cannot; an example such as \**Ik ben verbaasd over een (mooie) boeken dat hij heeft!* is unacceptable.

- (443) a. *De boeken die Peter leest!*  
           the books REL Peter reads  
           ‘The books Peter is reading!’  
       b. *Ik ben verbaasd over de boeken die Peter leest.*  
           I am surprised about the books that Peter read  
           ‘I am surprised about the books that Peter is reading.’

The discussion above suggests that (443a) is simply an elided form of a declarative clause such as (443b), and it is therefore not immediately obvious that an exclamative interpretation can be attributed to identifiable syntactic properties of the construction; we might as well be dealing with a pragmatically determined interpretation. This is consistent with the observation that “incomplete” sentences more generally have special features; Evans (2007) and Boogaart & Verhey (2013), for instance, claim that independently used non-main clauses such as the declarative in (444) are normally used in order to express a special emotional (exclamative) value.

- (444) Dat je dat durft!  
 that you that dare  
 Approximately: ‘Boy, that you dare to do that! You have a nerve!’

The interpretation of examples such (444) is evidently a performance phenomenon related to language use, and not related to syntactic competence. Furthermore, it seems that many cases are more or less idiomatic in nature, that is, not productively derived by means of deletion of a matrix clause; an exclamation like (445), for example, does not allow the addition of a matrix clause. That the exclamation in (445b) is idiomatic in nature is also clear from the fact that *En of!* can be used as an independent utterance to express emphatic confirmation or even an expression of high degree. *Ben je blij? En of!* ‘Are you glad? Yes, very much so!’.

- (445) A. Dat durf je niet. B. En of ik dat durf!  
 that dare you not and if I that dare  
 ‘A. You wouldn’t dare! B. O, yes, I would!’

Other cases of independently used non-main clauses, which were recently discussed by Nouwen & Chernilovskaya (2013/2014) as an additional type of *wh*-exclamative, are given in the primeless examples in (446). That the primed examples can be easily used as regular complement clauses suggests again that the exclamative import of the primeless examples can be attributed to the fact that we are dealing with “incomplete” sentences. For this reason, we do not accept Nouwen & Chernilovskaya’s claim that the examples in (446a&b) instantiate a new type of *wh*-exclamative.

- (446) a. Wie ik nou weer gezien heb!  
 who I PRT PRT seen have  
 a’. Je raadt nooit [wie ik nou weer gezien heb].  
 you guess never who I PRT PRT seen have  
 ‘You’ll never guess who I have seen just now.’  
 b. Wat voor boek hij nou weer aan het lezen is!  
 which book he PRT PRT AANHET read is  
 b’. Je raadt nooit [wat voor boek hij nou weer aan het lezen is].  
 you guess never what for book he PRT PRT AANHET read is  
 ‘You’ll never guess what kind of book he is reading now.’

Another reason to not adopt this claim is that the primeless examples in (446) exhibit none of the properties of the *wh*-exclamatives discussed in the previous subsections. First, they do not have a higher-than-expected-degree or a larger-than-expected-quantity reading, which is consistent with the fact that they do not contain an independent, designated element that can be held responsible for introducing a degree variable. Second, the *wh*-element in clause-initial position is independently licensed as an argument of the embedded clause and, consequently, there is no clear reason for assuming that it functions as an exclamative operator; we are simply dealing with the operator-variable relation normally found in interrogative clauses.



### C. Conclusion

This subsection has argued that we must make a terminological distinction between exclamation and exclamative; the latter denotes a subset of exclamations that are syntactically marked as such. The fact that the use of an exclamative intonation pattern is not sufficient for assuming exclamative status forces us to pinpoint specific properties as defining characteristics of exclamatives. Taking the discussion of *wh*-exclamatives as our point of departure we have assumed the following: (i) exclamatives involve an exclamative *wh*-element, which acts as an exclamative operator; (ii) the exclamative operator is licensed by binding a variable introduced by some designated element in the clause; (iii) the operator and the variable enter into a local syntactic dependency relation, which means that they must be part of the same clause. Because the operator and the variable are sometimes phonetically empty, it is not always easy to determine whether the defining properties are indeed present, and we therefore occasionally have to appeal to meaning, that is, to the question as to whether the construction has a higher-than-expected-degree or a larger-than-expected-quantity reading. We applied these criteria to a small sample of exclamation types in order to determine which types are eligible for a syntactic account and which types should be accounted for by other means (lexicon, pragmatics, etc.). Given the lack of sufficiently sophisticated syntactic investigations on exclamatives, our conclusion should be considered to be of a preliminary nature.

#### 11.3.5. Comparative (sub)deletion

This section discusses the role of *wh*-movement in the derivation of comparative-deletion and comparative-subdeletion constructions. The former construction is illustrated in (447), and is characterized by the fact that the comparative *dan/als*-phrase contains an interpretative gap, indicated by [e]. This gap receives an interpretation on the basis of (a phrase containing) an equative/comparative adjective in the matrix clause. The use of the equative form *even lang* ‘as long’ in (447a) expresses that the length of table<sub>1</sub> equals the length of table<sub>2</sub>; the interpretative gap in the *als*-phrase thus receives the interpretation [Δ long] in which Δ functions as the modifier that stands for a certain degree of length. The use of the majorative form *meer* ‘more’ in (447b) expresses that the number of books owned by Jan exceeds the number of books that Jan is able to read; the interpretative gap in the *dan*-phrase thus receives the interpretation [[Δ much] books] in which [Δ much] functions as a quantifier indicating quantity. Note in passing that we have placed the copular verb in the *als*-phrase in (447a) within parentheses to indicate that it can be (and in fact preferably is) elided under identity with the copular in the matrix clause; we will ignore this form of elision in the discussion below.

- (447) • Comparative deletion
- a. Die tafel is even lang als deze tafel [e] (is).  
 that table is as long as this table is  
 ‘That table is as long as this table (is).’
  - b. Jan heeft meer boeken dan hij [e] kan lezen.  
 Jan has more books than he can read  
 ‘Jan has more books than he can read.’

The interpretative gaps in the sentences in (447) must be syntactically present as they function as selected clausal constituents; the interpretative gap functions as a °complementive in the copular construction in (447a) and as a direct object in the transitive construction in (447b). The examples in (448) show, however, that the interpretative gap can also be smaller than a clausal constituent. Example (448a) expresses that *the length of table<sub>1</sub>* equals *the width of table<sub>2</sub>*, and the interpretative gap in the *als*-phrase thus corresponds to a subpart of the complementive; it is interpreted as the degree variable  $\Delta$  of the adjectival phrase [ $\Delta$  wide]. Example (448b) expresses that the *number of books owned by Jan* exceeds the *number of CDs owned by Els*, and the interpretative gap thus corresponds to a subpart of the direct object; it receives the quantifier interpretation [ $\Delta$  much] of the noun phrase [[ $\Delta$  much] CDs].

- (448) • Comparative subdeletion
- a. Die tafel is even lang als deze tafel [[e] breed] (is).  
that table is as long as this table wide is  
'That table is as long as this table is wide.'
  - b. Jan heeft meer boeken dan Els [[e] cd's] (heeft).  
Jan has more books than Els CDs has  
'Jan has more books than Els has CDs.'

This section will not provide a full discussion of comparative (sub)deletion because this is the topic of Section A4.1.3. We will focus here on the hypothesis put forward in Chomsky (1973/1977) that the interpretative gaps in the examples above are the result of *wh*-movement (while the *wh*-moved phrases themselves are subsequently deleted under "identity" with their associates in the matrix clauses). The following subsections argue that although this hypothesis seems feasible for comparative deletion, there are reasons not to accept it for comparative subdeletion. We will not discuss alternative analyses for the comparative-subdeletion construction, but refer the reader to Corver (2006) and Corver & Lechner (In prep), who discuss various proposals found in the linguistic literature.

### 1. Comparative Deletion

An important difference between the comparative-deletion construction and the *wh*-movement constructions discussed in Sections 11.3.1 to 11.3.4 is that the former does not have a phonetically visible *wh*-moved antecedent for the interpretative gap: if such an antecedent is present, we have to assume that it is deleted or at least left phonetically unexpressed under "identity" with (a phrase containing) the equative or comparative form that selects the *dan/als*-phrase. This makes it hard to firmly establish (or to refute) the claim that *wh*-movement is involved in the derivation of comparative-deletion constructions. In order to do this we should show that the construction exhibits at least the three characteristic properties of *wh*-movement listed in (449).

- (449) a. There is an obligatory interpretative gap, viz., the trace left by *wh*-movement.  
b. The antecedent-trace relation can be non-local in bridge contexts.  
c. The antecedent-trace relation is island-sensitive.

That there is an interpretative gap was already shown in the introduction to this section on the basis of the meaning of the constructions in (447): we have seen, for instance, that example (450a), expresses that the *number of books owned by Jan exceeds* the *number of books that he can read*. That the gap is obligatory can furthermore be shown by the fact illustrated in (450b) that its position cannot be taken by an overt noun phrase (except, of course, for bare noun phrases with a more deeply embedded interpretative gap in comparative-subdeletion constructions).

- (450) a. Jan heeft meer boeken dan hij [e] kan lezen.  
 Jan has more books than he can read  
 'Jan has more books than he can read.'
- b. \*Jan heeft meer boeken dan hij de krant kan lezen.  
 Jan has more books than he the newspaper can read

This suggests that the comparative *dan*-phrase in (450a) must have a phonetically empty direct object that is associated with the overt direct object in the matrix clause containing the comparative, *meer boeken* 'more books'. We will assume that *wh*-movement establishes this association by moving the (phonetically empty) phrase sufficiently close to its antecedent in the matrix clause. Because *wh*-movement normally results in the formation of an operator-variable chain of some sort, we will henceforth refer to the moved phrase by means of the notion EMPTY OPERATOR (thus putting aside the question as to whether the construction involves deletion of the *wh*-phrase).

There is some dispute about the precise landing site of the empty operator, which is related to the fact that the categorial status of the element *dan* 'than' (as well as *als* 'as') is also unclear. Although it is sometimes claimed that *dan* is a complementizer (that is, a subordinating conjunction), we will provisionally assume that it is a preposition-like element that is able to select a clausal complement. This seems consistent with the fact that in colloquial speech the element *dan* can be optionally followed by *dat* in examples such as (450a); because *dat* should clearly be analyzed as the complementizer of the embedded clause, it seems unlikely that *dan* has the same function. If the above is correct, we may assign example (450a) the structure in (451a). The claim that *dan* is preposition-like can further be supported by the fact illustrated in (451b) that it can also be followed by a noun phrase. We refer the reader to Section A4.1.3.3 for a more detailed discussion.

- (451) a. Jan heeft meer boeken [<sub>PP</sub> dan [<sub>CP</sub> Op<sub>i</sub> (dat) [<sub>TP</sub> hij t<sub>i</sub> kan lezen]]].  
 Jan has more books than that he can read  
 'Jan has more books than he can read.'
- b. Jan heeft meer boeken [<sub>PP</sub> dan [<sub>NP</sub> alleen *Eline Vere* van Couperus]].  
 Jan has more books than just *Eline Vere* by Couperus  
 'Jan has more books than just *Eline Vere* by Couperus.'

If *wh*-movement is indeed involved in the derivation of comparative-deletion constructions, we expect that the interpretative gap can be embedded in complement clauses selected by °bridge verbs like *denken* 'to think' and *zeggen* 'to say'. The examples in (452) show that this expectation is indeed borne out.

- (452) a. Jan heeft meer boeken dan ik denk dat hij [e] gelezen heeft.  
 Jan has more books than I think that he read has  
 ‘Jan has more books than I think that he has read.’
- b. Jan heeft meer boeken dan ik denk dat Els zei dat hij [e] gelezen heeft.  
 Jan has more books than I think that Els said that he read has  
 ‘Jan has more books than I think that Els said that he has read.’

We furthermore expect comparative deletion to be excluded if the interpretative gap is embedded in an island for *wh*-movement. This is again borne out, as is illustrated in (453) for an interrogative and an adverbial clause, respectively. While the intended interpretations in the primed examples are perhaps hard to grasp but seem intelligible, the corresponding sentences in the primeless examples are utter gibberish.

- (453) a. \*Jan heeft meer boeken dan ik vroeg [of hij [e] gelezen had].  
 Jan has more books than I asked if he read had
- a'. Intended reading: Jan has *n* books & I asked whether Jan had read *m* books  
 &  $n > m$
- b. \*Jan heeft meer boeken dan ik hem bewonder [omdat hij [e] gelezen heeft].  
 Jan has more books than I him admire because he read has
- b'. Intended reading: Jan has *n* books & I admire Jan because he has read  
*m* books &  $n > m$

The island-sensitivity of comparative deletion can also be illustrated by means of the contrast between the two constructions in (454). Den Besten (1978) claims that these examples differ in that the element *dan* takes a clausal complement in (454a), but a nominal complement in the form of a free relative in (454b). If this proposal is on the right track, the contrast between the two examples can be attributed to the fact that *wh*-movement can only strand a preposition if the PP is pronominalized, that is, if it has the form *waar* + P.

- (454) Jan heeft meer geld verdiend ...  
 Jan has more money earned
- a. \*... dan [<sub>CP</sub> Op<sub>i</sub> (dat) [<sub>TP</sub> zijn vrouw [<sub>PP</sub> op *t*<sub>i</sub>] gerekend had]].  
 than that his wife on counted had  
 Intended reading: ‘Jan has made more money than his wife counted on.’
- b. ... dan [<sub>NP</sub> Ø [<sub>CP</sub> waar<sub>i</sub> Ø [<sub>TP</sub> zijn vrouw [<sub>PP</sub> *t*<sub>i</sub> op] gerekend had]]].  
 than REL COMP his wife on counted had  
 ‘Jan has made more money than his wife had counted on.’

The discussion above has shown that comparative deletion does indeed exhibit the three characteristic properties of *wh*-movement in (449): (i) the interpretative gap in the *dan/als*-phrase is obligatory and cannot be filled by some overt phrase (provided we put aside the comparative subdeletion-constructions); (ii) on the assumption that an empty operator is moved into the clause-initial position of the clause selected by *dan*, movement of this operator applies in an apparent non-local fashion in bridge contexts; (iii) movement of the empty operator is island-sensitive.

*II. Comparative subdeletion*

Comparative-subdeletion constructions pose the same problem for establishing that *wh*-movement is involved in their derivation as Comparative-deletion constructions do. In order to show this, we should again prove that the construction exhibits at least the three properties of *wh*-movement in (449). That there is an interpretative gap was already shown in the introduction to this section on the basis of the meaning of the constructions in (448): example (455a), for instance, expresses that *the number of books owned by Jan exceeds the number of CDs owned by Els*. That the empty quantifier is obligatory is shown by the fact illustrated in (455b) that its position cannot be filled by an overt numeral/quantifier. This suggests that the direct object of the comparative *dan*-phrase in (455a) must contain a phonetically empty quantifier associated with the quantifier *meer* ‘more’ of the direct object in the matrix clause *meer boeken* ‘more books’.

- (455) a. Jan heeft meer boeken dan Els [[e] cd's] (heeft).  
 Jan has more books than Els CDs has  
 ‘Jan has more books than Els has CDs.’
- b. \*Jan heeft meer boeken dan Els [duizend/veel cd's] (heeft).  
 Jan has more books than Els thousand/many CDs has

The examples in (456) show that, as predicted by the *wh*-movement hypothesis, the interpretive gap can also be more deeply embedded in bridge contexts; the question mark between parentheses indicate that some speakers consider these examples slightly marked.

- (456) a. <sup>(?)</sup>Jan heeft meer boeken dan ik denk dat Els [[e] cd's] (heeft).  
 Jan has more books than I think that Els CDs has  
 ‘Jan has more books than I think Els has CDs.’
- b. <sup>(?)</sup>Jan heeft meer boeken dan ik denk dat Peter zei dat Els [[e] cd's] (heeft).  
 Jan has more books than I think that Peter said that Els CDs has  
 ‘Jan has more books than I think that Peter said that Els has CDs.’

The examples in (457) further show that comparative subdeletion is sensitive to interrogative and adjunct islands. The intended interpretations are perhaps difficult to grasp but seem intelligible, while the sentences are again utter gibberish.

- (457) a. \*Jan heeft meer boeken dan ik vroeg of Els [[e] cd's] (had).  
 Jan has more books than I asked if Els CDs had
- a'. Intended reading: Jan has *n* books & I asked whether Els had *m* CDs &  $n > m$
- b. \*Jan heeft meer boeken dan ik Els bewonder omdat zij [[e] cd's] heeft.  
 Jan has more books than I Els admire because she CDs has
- b'. Intended reading: Jan has *n* books & I admire Els because she has *m* CDs &  $n > m$

The data discussed so far are consistent with the *wh*-movement hypothesis, but there are also problems for this hypothesis. The first one is that the empty operator in (455a) is a quantifier modifying a noun phrase; the examples in (458) show that noun phrases are normally islands for *wh*-movement of such modifiers; movement of the quantifier *hoeveel* obligatorily pied pipes the containing noun phrase.

- (458) a. [Hoeveel cd's]<sub>i</sub> heeft Els *t*<sub>i</sub> gekocht?  
 how.many CDs has Els bought  
 'How many CDs has Els bought?'  
 b. \*Hoeveel<sub>i</sub> heeft Els [*t*<sub>i</sub> cd's] gekocht?  
 how.many has Els CDs bought

The hypothesis that comparative-subdeletion constructions are derived by *wh*-movement therefore requires some special stipulation. One feasible analysis could perhaps be built in analogy to the constructions in (459), which show that quantified noun phrases like (459a) alternate with the construction in (459b) with so-called quantitative *er*, which replaces the lexical part of the noun phrase. We follow Coppen (1991) and Barbiers (2009) by assuming that *er* is extracted from the noun phrase by leftward movement (although Section N6.3 has shown that this analysis is not without problems).

- (459) a. Els heeft gisteren [veel cd's] gekocht.  
 Els has yesterday many CDs bought  
 'Els bought many CDs yesterday.'  
 b. Els heeft *er*<sub>i</sub> gisteren [veel *t*<sub>i</sub>] gekocht.  
 Els has there yesterday many bought

The examples in (460) show that quantitative *er* may optionally occur in comparative-deletion constructions; cf. Bennis (1977). We can simply account for this by assuming that the interpretative gaps in the two constructions in (460) differ: the gap in (460a) receives the interpretation [[ $\Delta$  much] books] while the gap in (460b) receives the interpretation [[ $\Delta$  much] *t*], with *t* acting as the trace of quantitative *er*.

- (460) a. Jan heeft meer boeken dan hij [e] kan lezen.  
 Jan has more books than he can read  
 'Jan has more books than he can read.'  
 b. Jan heeft meer boeken dan hij er [e] kan lezen.  
 Jan has more books than he there can read  
 'Jan has more books that he can read.'

This means that the two constructions in (460) are derived by comparative deletion, as the interpretative gap [e] corresponds to the full direct object in both cases. Observe that, if we follow this analysis, the noun phrase [[ $\Delta$  much] *t*] operator must be able to be *wh*-moved across quantitative *er*; this does not pose any special problem, as is clear from the fact that it is also possible to move the remnant noun phrase in (461) across *er*.

- (461) [Hoeveel *t*<sub>i</sub>]<sub>j</sub> heeft Els *er*<sub>i</sub> gisteren *t*<sub>j</sub> gekocht?  
 how.many has Els there yesterday bought  
 'How many [CDs] did Els buy yesterday?'

The acceptability of subextraction of quantitative *er* may lead to the conclusion that it should be possible more generally to subextract the lexical part of a noun phrase while stranding the functional part of it. We have reasons for assuming that this is

possible in principle, as some varieties of (Brabantian) Dutch and German exhibit this property in so-called split-topicalization constructions such as (462b). We again assume a movement analysis (although Van Hoof, 2006, shows that this analysis is not without problems).

- (462) a. Hij heeft [<sub>NP</sub> een helehoop koeien] in de wei.  
 he has a lot cows in the field  
 'He has a lot of cows in the field.'
- b. Koeien<sub>i</sub> heeft hij [<sub>NP</sub> een helehoop *t<sub>i</sub>*] in de wei.  
 cows has he a lot in the field

If lexical projections can really be extracted from their noun phrase while stranding their quantifier, this would open the possibility to reanalyze the comparative-subdeletion construction in (455a) as in (463); the underlying structure would then be approximately as in (463a), while the structure in (463b) is derived by extraction of the lexical part of the noun phrase; the surface structure in (463c) is derived by movement of the phonetically empty remnant of the noun phrase ([[ $\Delta$ -much] *t<sub>i</sub>*]) into clause-initial position.

- (463) Jan heeft meer boeken ...  
 Jan has more books
- a. ... dan [<sub>CP</sub> (dat) [<sub>TP</sub> Els [[ $\Delta$ -much] cd's] (heeft))].  
 than that Els CDs has
- b. ... dan [<sub>CP</sub> (dat) [<sub>TP</sub> Els cd's<sub>i</sub> [[ $\Delta$ -much] *t<sub>i</sub>*] (heeft))].  
 than that Els CDs has
- c. ... dan [<sub>CP</sub> [[ $\Delta$ -much] *t<sub>i</sub>*]<sub>j</sub> (dat) [<sub>TP</sub> Els cd's<sub>i</sub> *t<sub>j</sub>* (heeft))].  
 than that Els CDs has

This derivation unifies comparative deletion and comparative subdeletion (for cases involving quantified noun phrases) but the cost is high; we have to make additional stipulations for Standard Dutch in order to block *wh*-movement of the lexical part of the noun phrase in (463b) outside the domain of comparative deletion constructions. Another reason not to follow this line of inquiry is that a *wh*-movement analysis of comparative subdeletion also violates other well-known restrictions on *wh*-movement. Example (464a) shows, for instance, that the interpretative gap can be part of a nominal complement of a PP, while the (b)-examples show that *wh*-movement of a subpart of a nominal complement of a PP is impossible by means of the *wat voor* split: *wh*-movement of *wat* obligatorily triggers pied piping of the full PP.

- (464) a. Jan kijkt naar meer tv-series dan (dat) hij naar [[e] films] kijkt.  
 Jan looks at more television.series than that he at movies looks  
 'Jan watches more television series than he watches movies.'
- b. [Naar [wat voor films]]<sub>i</sub> kijkt Jan graag *t<sub>i</sub>*?  
 at what for movies looks Jan gladly  
 'What kind of movies does Jan like to watch?'
- b'. \*Wat<sub>i</sub> kijkt Jan graag [naar [*t<sub>i</sub>* voor films]]?  
 what looks Jan gladly to for films



### III. Conclusion

This section has looked at the role of *wh*-movement in comparative-deletion and comparative-subdeletion constructions. We have shown that there is good reason for assuming that comparative deletion is derived by means of *wh*-movement of an empty operator into the initial position of the clause selected by the prepositional-like element *als/dan*; this movement may be motivated by the need to place the empty operator in a sufficiently local relation with its associate, (the phrase containing) the equative/comparative adjective phrase in the matrix clause. The proper analysis of comparative subdeletion is much less clear: providing a *wh*-movement analysis seems to require the postulation of several *ad hoc* stipulations. It is therefore not surprising that this construction is still subject of ongoing debate. We refer the reader to Corver & Lechner (In prep) for a detailed discussion of the current state-of-affairs.

#### 11.3.6. Reconstruction

Normally, *wh*-movement is semantically or functionally motivated, which is especially clear in the case of *wh*-questions and topicalization constructions: *Wh*-movement in question (465a) is needed to create the operator-variable configuration in (465a'), while topicalization in example (465b) results in a special information-structural configuration, such as the topic-comment structure in (465b'). The traces indicated by *t* in the primeless examples in (465) are traditionally motivated by the fact that the displaced elements *wat* 'what' and *dit boek* 'this book' also perform the syntactic function of direct object; they indicate the designated argument position that is assigned the thematic role of theme as well as accusative case by the transitive main verb *kopen* 'to buy'.

- (465) a.  $Wat_i$  heeft Peter  $t_i$  gekocht?  
 what has Peter bought  
 'What has Peter bought?'
- a'.  $?x$  (Peter has bought  $x$ )
- b.  $Dit\ boek_i$  heeft Peter  $t_i$  gekocht.  
 this book has Peter bought  
 'This book, Peter has bought.'
- b'. [<sub>TOPIC</sub> DIT boek] [<sub>COMMENT</sub> heeft PETER gekocht].

Of course, there are theories in which thematic roles and/or case are assigned in the surface position of the *wh*-phrase but there are empirical reasons for assuming that these elements are semantically interpreted in the position of their trace, a phenomenon that has become known as RECONSTRUCTION; we refer the reader to Subsection IIB for the origin of this technical notion. This section will mainly illustrate reconstruction effects by means of the °binding properties of *wh*-moved elements; see Barrs (2001) for a similar review for English. Subsection I will therefore start by providing some theoretical background on binding. Given that reconstruction facts are easiest to demonstrate by means of topicalization, Subsection II will start with a discussion of this structure; reconstruction in questions and relative clauses is discussed in, respectively, III and IV. As the discussion of topicalization, *wh*-movement and relativization suffices to sketch a

general picture of the issues involved, we will not discuss reconstruction in *wh*-exclamative and comparative (sub)deletion constructions (which have in fact not played a major role in the descriptive and theoretical literature on the phenomenon so far).

### 1. Binding

Most research on binding is based on the empirical observation that referential personal pronouns such as *hem* ‘him’ and (complex) reflexive personal pronouns such as *zichzelf* ‘himself’ are in complementary distribution; this is illustrated for Dutch in the primeless examples in (466), in which coreferentiality is indicated by italics. The primed examples show that referential non-pronominal noun phrases normally cannot be used if a referential or a reflexive personal pronoun is possible; these examples are excluded on the reading that *Jan* and *de jongen* refer to the same individual.

- (466) a. Ik denk [dat *Jan* *zichzelf*/\**hem* bewondert].  
 I think that Jan himself/\*him admires  
 ‘I think that Jan admires himself.’
- a'. \*Ik denk [dat *Jan* *de jongen* bewondert].  
 I think that Jan the boy admires
- b. *Jan* denkt [dat ik *hem*/\**zichzelf* bewonder].  
 Jan thinks that I him/himself admire  
 ‘Jan thinks that I admire him.’
- b'. \**Jan* denkt [dat ik *de jongen* bewonder].  
 Jan thinks that I the boy admire

Data like (466) are accounted for by binding theory, which has found its classic formulation in the so-called binding conditions proposed in Chomsky (1981), which we provide in a somewhat loose formulation as (467).

- (467) • Binding conditions
- Reflexive and reciprocal personal pronouns are bound in their local domain.
  - Referential personal pronouns are free (= not bound) in their local domain.
  - Referential noun phrases like *Jan* or *de jongen* ‘the boy’ are free.

These conditions are extensively discussed in Section N5.2.1.5, but we will repeat some core issues here that are needed for our present purposes. A noun phrase is said to be bound if it is coreferential with a c-commanding antecedent. The term °c-command refers to an asymmetric syntactic relation between the constituents in a sentence, which can be made more precise by means of the hierarchy in (468), in which  $A > B$  indicates that A c-commands B and everything that is embedded in B.

- (468) C-command hierarchy:  
 subject > direct object > indirect object-PP > PP-complement > adjunct

We can thus say that, under the intended coreferential readings, the direct objects in the (a)-examples in (466) are bound by the subject noun phrase *Jan* of the embedded clause, and that the embedded nominal direct objects in the (b)-examples are bound by the subject noun phrase *Jan* of the main clause; recall that  $A > B$  in

(468) indicates that A c-commands B *and everything that is embedded in B*. Now consider again the three binding conditions in (467), which are normally referred to as conditions A, B and C. The fact that the primed examples in (466) are ungrammatical on the intended readings shows that c-command does not suffice to license binding: binding condition C expresses this by saying that a referential non-pronominal noun phrase cannot have a c-commanding antecedent at all. Binding conditions A and B further express that reflexive/reciprocal and referential personal pronouns differ with respect to the syntactic domain in which binding is possible, that is, in which they must/can have a c-commanding antecedent. If we assume for the moment that the relevant domain is the minimal clause in which we find the bound element, the data in (466a&b) follow: in (466a) the antecedent *Jan* is within the local domain of the pronoun, and binding conditions A and B predict that a reflexive pronoun can, but a referential pronoun cannot be bound by *Jan*; in (466b) the antecedent *Jan* is not within the local domain of the pronoun, and binding conditions A and B predict that a referential pronoun can, but a reflexive pronoun cannot be bound by *Jan*. This derives the complementary distribution of the referential and reflexive personal pronouns illustrated in (466a&b).

The crucial thing for our discussion of reconstruction is that it is normally assumed that the c-command hierarchy in (468) is not a primitive notion, but derived from the *hierarchical structural relations* between the elements mentioned in it. It suffices for our present purpose to say that the subject of a clause c-commands the direct object of the same clause because the former is in a structurally higher position than the latter; in the overall structure of the clause given in (469), which is extensively discussed in Chapter 9, the subject occupies the specifier position of TP immediately following the C-position, while the object occupies some lower position within XP.

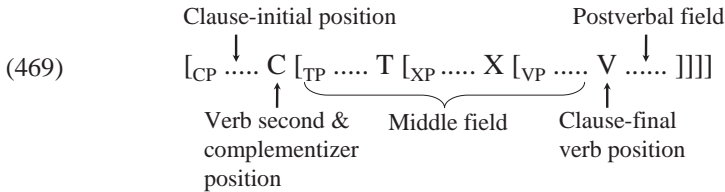

If c-command should indeed be defined in terms of structural representations, *wh*-movement affects the c-command relations between the clausal constituents: after *wh*-movement of the object into the specifier of CP, the object will c-command the subject in the specifier of TP. We therefore expect *wh*-movement to alter the binding possibilities, but the following subsections will show that this expectation is not borne out; the *wh*-moved phrase normally behaves as if it still occupies its original position.

## II. Topicalization

That *wh*-movement does not affect binding relations can be easily demonstrated by means of topicalization. We will start with a presentation of the core data, which shows that the binding possibilities are computed from the original position of the

topicalized phrase. After this, we will briefly compare reconstruction effects with so-called connectivity effects found in contrastive left-dislocation constructions.

A. *The data*

If the binding conditions were calculated from the landing site of *wh*-movement, topicalization of a reflexive pronominal direct object is expected to bleed binding. Example (470b) shows, however, that with respect to binding the topicalized reflexive pronoun *zichzelf* behaves as if it is still in the position indicated by its  $^{\circ}$ trace; coreferentiality is again indicated by italics.

- (470) a. *Jan* bewondert *zichzelf* het meest.  
 Jan admires himself the most  
 ‘Jan admires himself the most.’  
 b. *Zichzelf*<sub>i</sub> bewondert *Jan* *t*<sub>i</sub> het meest.  
 himself admires Jan the most  
 ‘Himself Jan admires the most.’

That topicalization does not bleed binding can also be illustrated by means of the examples in (471), in which a reciprocal possessive pronoun is embedded in a direct object; topicalization of this object does not affect the binding possibilities. Note in passing that, contrary to reciprocal and referential personal pronouns, reciprocal and referential possessive pronouns are not in complementary distribution given that *elkaars* can readily be replaced by *hun* ‘their’; we refer the reader to Section N5.2.2 for detailed discussion.

- (471) a. *Zij* bewonderen [*elkaars* moeder] het meest.  
 they admire each.other’s mother the most  
 ‘They admire each other’s mother the most.’  
 b. [*Elkaars* moeder]<sub>i</sub> bewonderen *zij* *t*<sub>i</sub> het meest.  
 each.other’s mother admire they the most  
 ‘Each other’s mother they admire the most.’

Another case showing that topicalization does not bleed binding is illustrated by the examples in (472), which allow a  $^{\circ}$ bound-variable reading of the possessive pronoun *zijn* ‘his’; according to this reading every person *x* admires his own parents:  $\forall x$  (*x*:person) ADMIRE (*x*, *x*’s parents). This reading only arises if the quantifier binds (hence: *c*-commands) a referential pronoun and we might therefore expect that topicalization in (472b) would make this reading impossible, but this expectation is not borne out.

- (472) a. *Iedereen* bewondert *zijn* (eigen) ouders het meest.  
 everyone admires his own parents the most  
 ‘Everyone admires his (own) parents the most.’  
 b. *Zijn* (eigen) ouders<sub>i</sub> bewondert *iedereen* *t*<sub>i</sub> het meest.  
 his own parents admires everyone the most  
 ‘His (own) parents everyone admires the most.’

If the binding conditions were calculated from the landing site of *wh*-movement, topicalization of a referential (pronominal) direct object is expected to

enable it to function as the antecedent of the subject of its clause, but example (473b) shows that this is not the case: with respect to binding the objects *hem* and *die jongen* again behave as if they are still in the position indicated by their trace.

- (473) a. \**Jan* bewondert *hem/die jongen* het meest.  
           *Jan* admires    *him/that boy*    the most  
       b. \**Hem<sub>i</sub>/Die jongen<sub>i</sub>* bewondert *Jan t<sub>i</sub>* het meest.  
           *him/that boy*        admires    *Jan*    the most

A plausible hypothesis would of course be that example (473b) is unacceptable because the subject *Jan* is bound by the topicalized phrase and thus violates binding condition C. This hypothesis is, however, refuted by the fact that the matrix subject *Jan* in (474b) *can* be coreferential with the topicalized pronoun *hem* ‘him’: the example is perhaps somewhat marked compared to example (466b) but this seems to be a more general property of long topicalization; see the discussion in Section 11.3.3, sub II. This again leads to the conclusion that *wh*-movement does not affect binding possibilities.

- (474) a. *Jan* denkt [dat ik *hem/\*die jongen* het meest bewonder].  
           *Jan* thinks    that I    *him/that boy*        the most    admire  
           ‘*Jan* thinks that I admire *him* the most.’  
       b. <sup>(?)</sup>*Hem/\*Die jongen* denkt *Jan* [dat ik *t<sub>i</sub>* het meest bewonder].  
           *him/that boy*        thinks *Jan*    that I        the most    admire  
           ‘*Him Jan* thinks that I admire the most.’

Reconstruction is sometimes also illustrated in the literature by means of examples such as (475a), in which a bound nominal phrase is embedded in a complementive.

- (475) a. *Jan* is [<sub>AP</sub> trots [<sub>PP</sub> op *zichzelf/\*hem/\*die jongen*]].  
           *Jan* is        proud    of himself/him/that boy  
       b. [<sub>AP</sub> trots [<sub>PP</sub> op *zichzelf/\*hem/\*die jongen*]] is *Jan* niet.  
           proud    of himself/him/that boy        is *Jan* not

Some linguists do not accept (475b) as a convincing example of reconstruction as they assume that the subject originates as the external argument of the AP: on the assumption that the moved phrase is a full °small clause that contains an NP-trace of the subject *Jan*, this trace serves as an antecedent for the nominal phrase.

- (476) a. *Jan<sub>i</sub>* is [<sub>AP</sub> *t<sub>i</sub>* trots [<sub>PP</sub> op *zichzelf/\*hem/\*die jongen*]].  
           *Jan* is        proud    of himself/him/that boy  
       b. [<sub>AP</sub> *t<sub>i</sub>* trots [<sub>PP</sub> op *zichzelf/\*hem/\*die jongen*]]<sub>j</sub> is *Jan<sub>i</sub> t<sub>j</sub>* niet.  
           proud    of himself/him/that boy        is *Jan* not

However, even if the representations in (476) are the correct ones, reconstruction is still needed because it is generally assumed that NP-traces are subject to binding condition A as well: like reflexive pronouns, they must be bound by their antecedent (= the moved phrase) within their local domain.

For VP-topicalization constructions like (477b) more or less the same holds: some linguists who assume that the subject is base-generated in the lexical

projection of the verb do not accept it as a convincing example of reconstruction since they assume that the topicalized VP also contains the NP-trace of the subject *Jan*, which can serve as an antecedent. But even if this is true, reconstruction is still needed given that NP-traces are generally assumed to be subject to binding condition A as well.

- (477) a. *Jan<sub>i</sub> heeft* [<sub>VP</sub> *t<sub>i</sub> zichzelf/\*hem/\*die jongen* beschreven].  
 Jan has himself/him/that boy described  
 ‘Jan has described himself/him/that boy.’
- b. [<sub>VP</sub> *t<sub>i</sub> zichzelf/\*hem/\*die jongen* beschreven]<sub>j</sub> heeft *Jan<sub>i</sub> t<sub>j</sub>*.  
 himself/him/that boy described has Jan

If NP-traces must indeed be bound, VP-topicalization constructions of the type in (478) also provide evidence in favor of reconstruction. Under the standard assumption that the clause-initial position can be filled by phrases only (and not by heads), the theme argument must have been extracted from the VP by NP-movement (nominal argument shift of the type discussed in Section 13.2) before the VP is topicalized. The VP thus contains a trace of the theme argument and reconstruction is needed in order for the trace to be bound by the moved noun phrase *mijn huis* ‘my house’; see Section 11.3.3, sub VIC, for more discussion.

- (478) a. *Ze hebben mijn huis nog niet geschilderd.* [perfect tense]  
 they have my house yet not painted  
 ‘They haven’t painted my house yet.’
- a’. [<sub>VP</sub> *t<sub>i</sub> Geschilderd*]<sub>j</sub> hebben *ze mijn huis<sub>i</sub> t<sub>j</sub>* nog niet.  
 painted have they my house yet not  
 ‘They haven’t PAINTED my house yet.’
- b. *Mijn huis wordt volgend jaar geschilderd.* [passive]  
 my house is next year painted  
 ‘My house will be painted next year.’
- b’. [<sub>VP</sub> *t<sub>i</sub> Geschilderd*]<sub>j</sub> wordt *mijn huis<sub>i</sub> volgend jaar t<sub>j</sub>*.  
 painted is my house next year  
 ‘My house will be PAINTED next year.’

The examples so far all involve topicalization of arguments, complementives, and VP, and we have seen that such cases exhibit reconstruction effects: binding possibilities are computed from the base position of the moved phrase. This does not seem to hold for adjuncts, however, as is clear from the contrast between the two examples in (479); if the adverbial clause in (479b) were interpreted in the same position as the adverbial clause in (479a), we would wrongly expect coreference between *Jan* and *hij* to be blocked by binding condition C in both cases. This contrast has given rise to the idea that examples such as (479b) are actually not derived by *wh*-movement, but involve base-generation of the adjunct in clause-initial position; that this is possible is then attributed to the fact that adjuncts are not selected by the verb and can consequently be generated externally to the lexical projection of the verb.

- (479) a. \**Hij* ging naar de film [omdat *Jan* moe was].  
 he went to the movie because Jan tired was  
 b. [Omdat *Jan* moe was], ging *hij* naar de film.  
 because Jan tired was went he to the movie  
 ‘Because Jan was tired, he went to the movie.’

Note in passing that the lack of reconstruction cannot be demonstrated on the basis of binding condition B, as referential pronouns embedded in adverbial clause can always be coreferential with the subject of a matrix clause; this is shown in (480).

- (480) a. *Jan* ging niet naar de film [omdat *hij* moe was].  
 Jan went not to the movie because he tired was  
 ‘Jan didn’t go to the movie because he was tired.’  
 b. [Omdat *hij* moe was], ging *Jan* niet naar de film.  
 because he tired was went Jan not to the movie  
 ‘Because he was tired, Jan didn’t go to the movie.’

A similar lack of reconstruction can be observed in the examples in (481); cf. Van Riemsdijk & Williams (1981). In this case an argument is topicalized but the contrast between the two examples shows that the reconstruction effect is lacking: contrary to what would be expected if the topicalized phrase were interpreted in the position of its trace, the referential noun phrase *Jan* embedded in the relative clause can be coreferential with the pronoun *hij* in (481b). It is of course not possible to appeal to an argument-adjunct asymmetry in this case, but it has been suggested that the (optional) relative clause is an adjunct that can be generated *after* the object has undergone *wh*-movement; see Barss (2001) and Sportiche (2006) for details.

- (481) a. \**Hij* wil [het boek [dat *Jan* gekocht heeft]] aan Marie geven.  
 he wants the book that Jan bought has to Marie give  
 b. [Het boek [dat *Jan* gekocht heeft]]<sub>i</sub> wil *hij* <sub>*t*<sub>1</sub></sub> aan Marie geven.  
 the book that Jan bought has wants he to Marie give  
 ‘The book that Jan has bought, he wants to give to Marie.’

The examples in (482) show again that the lack of reconstruction cannot be demonstrated on the basis of binding condition B, as referential pronouns embedded in a relative clause can be coreferential with the subject of a matrix clause.

- (482) a. *Jan* wil [het boek [dat *hij* gekocht heeft]] aan Marie geven.  
 Jan wants the book that he bought has to Marie give  
 ‘Jan wants to give the book that he has bought to Marie.’  
 b. [Het boek [dat *hij* gekocht heeft]]<sub>i</sub> wil *Jan* <sub>*t*<sub>1</sub></sub> aan Marie geven.  
 the book that he bought has wants Jan to Marie give  
 ‘The book that he has bought, Jan wants to give to Marie.’

The discussion of the data in this subsection has shown that a reconstruction effect obligatorily occurs if some argument, complementive or verbal projection is topicalized. Reconstruction effects are absent if an adverbial clause occupies the clause-initial position or if the topicalized phrase is modified by a relative clause.



*B. Reconstruction versus connectivity effects*

Because *wh*-movement has a clear semantic import, the standard (but not uncontroversial) assumption is that it precedes the semantic interpretation of the clause. The fact that for the purpose of the binding theory formulated in (467) topicalized phrases behave as if they still occupy the position indicated by their traces has led to theories according to which *wh*-movement is at least partly *undone* before the semantic interpretation of the syntactic representation takes place; the technical term for this is RECONSTRUCTION. A more recent approach, which makes reconstruction superfluous, is Chomsky's (1995:ch.3) copy theory of movement, according to which movement is a copy-and-paste operation that leaves a phonetically empty copy (a copy that is not pronounced in the actual utterance) of the moved constituent in its original position. For convenience, we will follow general practice by maintaining the notion of reconstruction as a purely descriptive term. The core finding that all theories try to explain is that binding of nominal arguments should be formulated in terms of A-positions, that is, °argument positions to which thematic roles, agreement features and/or case are assigned; movement into A'-positions (positions such as the clause-initial position that may also be occupied by non-arguments) does not affect the binding possibilities. We refer the reader to Barrs (2001), Sportiche (2006) and Salzmann (2006) for critical reviews and discussions of the various theoretical implementations of this insight.

The standard view seems to be that reconstruction effects are syntactic in nature, but there are grounds for doubting that these effects are part of syntax proper. In order to show this we have to make a brief digression on contrastive and hanging-topic left-dislocation; see Section 14.2 for a more extensive discussion. LEFT DISLOCATION is characterized by the fact that there is some phrase *preceding* the clause-initial position, which is associated with a resumptive element elsewhere in the clause. The two types of left-dislocation constructions differ in the form and position of the resumptive element: HANGING-TOPIC left-dislocation constructions have a resumptive pronoun in the form of a referential pronoun such as *hem* 'him', which is located in the middle field of the clause, as in (483a); CONTRASTIVE left-dislocation constructions have a resumptive pronoun in the form of a demonstrative pronoun such as *die* 'that', which is located in clause-initial position, as in (483b). Observe that we indicate the relation between the left-dislocated phrase and the resumptive pronoun by means of indices (just like the relation between a moved phrase and its trace).

- (483) a. Jan<sub>i</sub>, ik heb hem<sub>i</sub> niet gezien. [hanging-topic LD]  
 Jan I have him not seen  
 'Jan I haven't seen him.'
- b. Jan<sub>i</sub>, die<sub>i</sub> heb ik t<sub>i</sub> niet gezien. [contrastive LD]  
 Jan DEM have I not seen  
 'Jan I haven't seen him.'

At first sight, the examples in (484) seem to show that left dislocation differs from topicalization in that it does affect the binding possibilities. Van Riemsdijk & Zwarts (1997) and Vat (1997) suggest, however, that the unacceptability of the examples in (484) is due to the fact that resumptive pronouns are referential pronouns which are subject to binding condition B of the binding theory by

themselves. In order to satisfy the binding conditions on the reflexive *zichzelf* ‘himself’ the resumptive pronouns *hem* ‘him’ and *die* ‘that’ must take the subject *Jan* as a local antecedent, which results in a violation of binding condition B. Observe that the binding conditions for the resumptive pronoun *die* in (484b) should be computed from its original object position indicated by its trace in object position.

- (484) a. \**Zichzelf<sub>i</sub>, Jan* bewondert *hem<sub>i</sub>* het meest. [hanging-topic LD]  
 himself Jan admires him the most  
 Intended meaning: ‘Jan admires himself the most.’  
 b. \**Zichzelf<sub>i</sub>, die<sub>i</sub>* bewondert *Jan t<sub>i</sub>* het meest. [contrastive LD]  
 himself DEM admires Jan the most  
 Intended meaning: ‘Jan admires himself the most.’

Violations of binding condition B induced by the resumptive pronouns themselves can be avoided if the reflexive/reciprocal pronoun is more deeply embedded in the topicalized phrase, as in the examples in (471). Their left-dislocation counterparts in (485) show that the two types of left dislocation exhibit different behavior in such cases; while the hanging-topic construction is rated as ungrammatical in Van Riemsdijk & Zwarts (1997) and Vat (1997), the contrastive left-dislocation construction is fully acceptable. The fact that the left-dislocated phrase can be interpreted in the position of the trace of the *wh*-moved demonstrative *die* has become known as the CONNECTIVITY EFFECT.

- (485) a. \**[Elkaars moeder]<sub>i</sub>, zij* bewonderen *haar<sub>i</sub>* het meest. [hanging topic LD]  
 each.other’s mother they admire her the most  
 ‘Each other’s mother they admire the most.’  
 b. *[Elkaars moeder]<sub>i</sub>, die<sub>i</sub>* bewonderen *zij t<sub>i</sub>* het meest. [contrastive LD]  
 each.other’s mother DEM admire they the most  
 ‘Each other’s mother they admire the most.’

Connectivity effects also arise in the left-dislocation counterparts of the topicalization construction in (472b) with a bound variable reading. Van Riemsdijk & Zwarts (1997) and Vat (1997) show that there is again a contrast between hanging-topic and contrastive left-dislocation.

- (486) a. \**[Zijn (eigen) ouders]<sub>i</sub>, iedereen* bewondert *ze<sub>i</sub>* het meest. [hanging-topic LD]  
 his own parents everyone admires them the most  
 b. *[Zijn (eigen) ouders]<sub>i</sub>, die<sub>i</sub>* bewondert *iedereen t<sub>i</sub>* het meest. [contrastive LD]  
 his own parents DEM admires everyone the most

For completeness’ sake, consider the contrastive left-dislocation constructions in (487), which show again that the acceptability judgments on the contrastive left-dislocation constructions are more or less the same as in the corresponding topicalization constructions in (473b) and (474b).

- (487) a. \**Hem<sub>i</sub>/Die jongen<sub>i</sub>, die<sub>i</sub>* bewondert *Jan t<sub>i</sub>* het meest.  
 him/that boy DEM admires Jan the most  
 b. <sup>(3)</sup>*Hem<sub>i</sub>/\*Die jongen<sub>i</sub>, die<sub>i</sub>* denkt *Jan* [dat ik *t<sub>i</sub>* het meest bewonder].  
 him/that boy DEM thinks Jan that I the most admire  
 ‘Him, Jan thinks that I admire the most.’

The discussion above has shown that contrastive left-dislocation constructions exhibit connectivity effects which closely resemble the reconstruction effects found in topicalization constructions. Given this similarity, it is tempting to provide a single theoretical account of the two types of effect. This might lead to the conclusion that there is some kind of matching effect in the sense that the demonstrative pronoun *die* simply takes over certain semantic properties of the left-dislocated phrase and transmits these to the position of its trace; however, this would go against the current idea that reconstruction effects follow from the copy theory of movement: the claim that movement is a copy-and-paste operation that leaves an actual copy of the moved constituent in its original position.

Alternatively, one might attempt to show that left-dislocated phrases are base-generated within the clause they are attached to and find their surface position by (a series of movements including) *wh*-movement. If such an analysis is feasible, we could maintain that reconstruction effects result from the copy-and-paste operation proposed by the copy theory of movement; see Grohmann (2003:ch.4) and De Vries (2009) for detailed proposals. This would immediately account for the differences in connectivity effects established in this subsection between hanging-topic and contrastive left-dislocation constructions: hanging-topic constructions have a resumptive pronoun in the middle field of the clause, and we can therefore safely conclude that they do not involve *wh*-movement, and we consequently expect connectivity effects to be absent. There are, however, two potential problems for this approach. First there does not seem to be independent evidence for assuming that left-dislocated phrases have ever occupied a clause-internal position. Second, this approach should provide a reasonable account for the fact that left-dislocated phrases may strand prepositions, while topicalized phrases (and *wh*-moved phrases in general) are normally not able to do that; see the contrast between the (a)- and (b)-examples in (488).

- (488) a. \*? Dat boek heb ik lang naar gezocht. [topicalization]  
           that book have I long for looked  
       a'. \*Wat heb je lang naar gezocht? [question formation]  
           what have you long for looked  
       b. Dat boek, daar heb ik lang naar gezocht. [contrastive LD]  
           that book that have I long for looked  
           'that book, I have looked for it a long time.'

We will return to the question as to whether reconstruction and connectivity effects can be given a (more or less) unified treatment in the discussion of relativization in Subsection IV below.

### III. *Wh*-movement

Section 11.3.1.1, sub II, discussed the hypothesis that the obligatoriness of *wh*-movement in *wh*-questions follows from the fact that it is instrumental in deriving an operator-variable chain in the sense of predicate calculus. It has also shown that this hypothesis runs into problems with examples like (489a&b), in which the moved *wh*-phrase is complex: the resulting syntactic representations cannot be directly translated into the desired semantic representations in the primed examples,

as only a *subpart* of the *wh*-moved phrase corresponds to the question operator plus restrictor: the possessive pronoun *wiens* ‘whose’ translates into  $?x$  [ $x$ : *person*]. The phenomenon of °pied piping thus makes it impossible to assume a one-to-one relationship between the surface form of a sentence and its semantic representation by simply stating that *wh*-movement creates an operator-variable chain. Question formation thus provides us with an *independent motivation* for some form of reconstruction; it is needed to arrive at the proper semantic representations for sentences like (489a&b).

- (489) a. [Wiens boek]<sub>i</sub> heeft Peter  $t_i$  gelezen?  
 whose book has Peter read  
 ‘Whose book has Peter read?’  
 a’.  $?x$  [ $x$ : *person*] (Peter has read  $x$ ’s book)  
 b. [Wiens vaders boek]<sub>i</sub> heeft Peter  $t_i$  gelezen?  
 whose father’s book has Peter read  
 ‘Whose father’s book has Peter read?’  
 b’.  $?x$  [ $x$ : *person*] (Peter has read  $x$ ’s father’s book)

It is, however, less easy to convincingly demonstrate reconstruction effects for *wh*-movement than for topicalization, as the predictions of the binding theory can only be checked for bound elements embedded in some noun phrase because interrogative pronouns are never reflexive/reciprocal themselves. Furthermore, examples like (490) are often quoted to support reconstruction, but they are completely unsuitable for this purpose; it has been argued that the picture noun *foto* may have an implied agentive PRO-argument which is obligatorily construed as coreferential with the subject *Jan*; see N2.2.5.2 for detailed discussion. If so, the reflexive is locally bound within the noun phrase by PRO in both examples.

- (490) a. *Jan* heeft [een PRO foto van *zichzelf*] genomen  
 Jan has a picture of himself taken  
 b. [Welke PRO foto van *zichzelf*]<sub>i</sub> heeft *Jan*  $t_i$  genomen?  
 which picture of himself has Jan taken

In order to construct convincing cases of reconstruction based on binding condition A, one must make sure that there is no implied PRO-argument that can be construed as coreferential with the antecedent of the reflexive/reciprocal pronoun. On the default interpretation of the examples in (491) that *Jan* did not spread rumors about himself, (491b) may be a case in point.

- (491) a. *Jan* vond [dit gerucht over *zichzelf*] het leukst.  
 Jan considered this rumor about himself the funniest  
 ‘Jan considered this rumor about himself the funniest one.’  
 b. [Welk gerucht over *zichzelf*]<sub>i</sub> vond *Jan*  $t_i$  het leukst?  
 which rumor about himself considered Jan the funniest  
 ‘Which rumor about himself considered Jan the funniest one?’

The bound variable reading of pronouns, which requires a c-commanding quantifier to be present, also indicates that reconstruction does apply. Without reconstruction example (492b) would be wrongly predicted not to allow this reading.

- (492) a. *Iedereen* vond de foto van *zijn* (eigen) moeder het mooist.  
 everyone considered the picture of his own mother the most.beautiful  
 ‘Everyone liked the picture of his (own) mother best.’
- b. De foto van *zijn* (eigen) moeder vond *iedereen* het mooist.  
 the picture of his own mother considered everyone the most.beautiful  
 ‘Everyone liked the picture of his (own) mother best.’

Arguments based on binding condition B are somewhat delicate because referential personal pronouns embedded within a noun phrase can often be coreferential with the subject of their clause if they are phonetically reduced. This is illustrated by the examples in (493), both of which are accepted by many speakers if the pronoun is phonetically reduced but rejected if the pronoun is non-reduced. The crucial point is, however, that topicalization does not seem to affect the acceptability judgments.

- (493) a. *Jan* vond [dit gerucht over 'm/\*hem] het leukst.  
 Jan considered this rumor about him/him the funniest  
 ‘Jan considered this rumor about him the funniest one?’
- b. [Welk gerucht over 'm/\*hem]<sub>i</sub> vond *Jan* t<sub>i</sub> het leukst?  
 which rumor about him/hem considered Jan the funniest  
 ‘Which rumor about him considered Jan the funniest one?’

The examples in (494) do provide straightforward evidence for reconstruction based on binding condition C; they are both unacceptable if the noun phrase *die popster* is construed as coreferential with *Jan*.

- (494) a. \**Jan* vond [dit gerucht over *die popster*] het leukst.  
 Jan considered this rumor about that pop.star the funniest  
 ‘Jan considered this rumor about that pop star the funniest one.’
- b. \*[Welk gerucht over *die popster*]<sub>i</sub> vond *Jan* t<sub>i</sub> het leukst?  
 which rumor about that pop-star considered Jan the funniest  
 ‘Which rumor about that pop star considered Jan the funniest one?’

Note that, as in the case of topicalization, reconstruction need not apply for noun phrases embedded in relative clauses; while *Jan* cannot be construed as coreferential with the subject pronoun *hij* in (495a), this is possible in (495b).

- (495) a. \**Hij* wil [het boek [dat *Jan* gekocht heeft]] aan Marie geven.  
 he want the book that Jan bought has to Marie given  
 ‘He wants to give the book that Jan has bought to Marie.’
- b. [Welk boek [dat *Jan* gekocht heeft]]<sub>i</sub> wil *hij* ·t<sub>i</sub> aan Marie geven?  
 which book that Jan bought has wants he to Marie give  
 ‘Which book that Jan has bought does he want to give to Marie?’

Despite the difficulty in constructing relevant examples, the arguments based on the bound variable reading of pronouns and binding condition C show conclusively that *wh*-questions exhibit similar reconstruction effects as topicalization constructions.

#### IV. Relativization

Reconstruction effects are even more difficult to establish in relative constructions than in *wh*-questions. We will see, however, that there is an additional twist to the discussion given that we find similar connectivity effects as discussed in Subsection IIB for contrastive left-dislocation constructions; this may shed more light on the question as to whether reconstruction and connectivity effects can be given a (more or less) unified account.

##### A. Reconstruction effects

As with *wh*-questions, reconstruction for binding condition A is again difficult to establish because the reflexive/reciprocal pronoun must be embedded within a larger phrase: relative pronouns are never reflexive/reciprocal themselves. Moreover, because the relative pronoun is typically a possessive pronoun such as *wiens* ‘whose’ in complex noun phrases, we expect that it will normally be construed as the antecedent of a reflexive/reciprocal pronoun within the *wh*-moved phrase; cf. Section N5.2.1.5. The impossibility of construing the subject as the antecedent of *zichzelf* in examples such as (496), in which the intended binding is again indicated by italics, therefore does not tell us anything about reconstruction.

- (496) a. de man<sub>i</sub> [[*wiens*<sub>i</sub> boek over *zichzelf*]<sub>j</sub> hij wil *t<sub>j</sub>* lezen]  
 the man whose book about himself he wants read  
 ‘the man whose book about himself he wants to read’  
 b. \*de man<sub>i</sub> [[*wiens*<sub>i</sub> boek over *zichzelf*]<sub>j</sub> *hij* wil *t<sub>j</sub>* lezen]  
 the man whose book about himself he wants read

Examples such as (497b) with a bound variable reading do seem to provide evidence for reconstruction, although some speakers may find it hard to give a judgment on this example due to its complexity.

- (497) a. *Iedereen* zal [Marie’s advies over *zijn* kinderen] volgen.  
 everyone will Marie’s advice about his children follow  
 ‘Everyone will follow Marie’s advice about his children.’  
 b. de vrouw<sub>i</sub> [*wiens*<sub>i</sub> advies over *zijn* kinderen]<sub>j</sub> *iedereen* *t<sub>j</sub>* wil volgen  
 the woman whose advice about his children everyone wants follow  
 ‘the woman whose advice about his children everyone will follow’

Reconstruction for binding condition B is again difficult to establish because referential pronouns embedded within a noun phrase containing a possessive pronoun can normally be coreferential with noun phrases external to that noun phrase. Moreover, the acceptability of (498b) does not tell us anything about reconstruction because referential pronouns do not require a c-commanding antecedent.

- (498) a. *Jan* negeerde [Peters opmerking over *hem*].  
 Jan ignored Peter’s remark about him  
 b. de man<sub>i</sub> [[*wiens*<sub>i</sub> opmerking over *hem*]<sub>j</sub> *Jan* *t<sub>j</sub>* negeerde]  
 the man whose remark about him Jan ignored  
 ‘the man whose remarks about him Jan ignored’

For binding condition C it is possible to show that reconstruction effects do occur: the intended coreference relation is excluded in both examples in (499). The fact that referential noun phrases may normally have a non-c-commanding antecedent suggests that reconstruction must apply.

- (499) a. \**Jan* negeerde [Peters opmerking over *die jongen*].  
 Jan ignored Peter's remark about that boy  
 b. \**de man*<sub>i</sub> [[*wiens*<sub>i</sub> opmerking over *die jongen*]<sub>j</sub> *Jan* *t*<sub>j</sub> negeerde]  
 the man whose remark about that boy Jan ignored

Despite the difficulty in constructing relevant examples, the arguments based on the bound variable reading of pronouns and binding condition C show conclusively that relative clauses exhibit similar reconstruction effects as *wh*-questions and topicalization constructions.

### B. Connectivity effects

The discussion in the previous subsection has shown that reconstruction within relative clauses is indeed obligatory. The research on relative clauses that has aroused most interest is, however, not concerned with reconstruction effects of the type discussed above but with connectivity effects of the kind we also found in contrastive left-dislocation constructions; cf. Subsection IIB.

The connectivity effect for binding condition A can be illustrated by means of example (500); on the default interpretation that the rumors are not spread by Jan himself, the reflexive pronoun *zichzelf* 'himself' can only be properly bound by *Jan* if the antecedent of the relative pronoun *dat* 'which' is interpreted in the position of the latter's trace.

- (500) [[Het gerucht over *zichzelf*]<sub>i</sub> [*dat*<sub>i</sub> *Jan* *t*<sub>i</sub> het leukst vond]] was  
 the rumor about himself which Jan the funniest considered was  
 dat hij opgegeten was door een leeuw.  
 that he prt.-eaten was by a lion  
 'The rumor about himself Jan liked best was that he had been eaten by a lion.'

Connectivity effects can also be illustrated by means of example (501) on its bound variable reading. Since this reading arises only if a quantifier binds (hence: c-commands) a referential pronoun, we have to assume that the antecedent of the relative pronoun *die* 'which' is interpreted in the position of the latter's trace.

- (501) [[De foto van *zijn* ouders]<sub>i</sub> [*die*<sub>i</sub> *iedereen* *t*<sub>i</sub> koestert]] is  
 the picture of his parents which everyone cherishes is  
 die van hun huwelijk.  
 the.one of their marriage  
 'The picture of his parents that everyone cherishes is the one of their marriage.'

Establishing connectivity effects for binding condition B is again somewhat delicate because referential personal pronouns embedded within a noun phrase can often be coreferential with the subject of their clause if they are phonetically reduced. Example (493) has shown, however, that phonetically non-reduced pronouns do not easily allow this. The fact that we do not find the same contrast in



the relative construction in (502) may go against the postulation of a connectivity effect, but we will leave this aside, as it is not clear whether we are really dealing with a syntactic restriction or with a restriction of some other type.

- (502) [[Het gerucht over 'm/hem]<sub>i</sub> [dat<sub>i</sub> Jan t<sub>i</sub> het leukst vond]] was  
 the rumor about him/him which Jan the funniest considered was  
 dat hij opgegeten was door een leeuw.  
 that he prt.-eaten was by a lion  
 'The rumor about him that Jan liked best was that he had been eaten by a lion.'

An even more serious problem is that connectivity effects for binding condition C are not found in relative clauses: example (503) does readily allow an interpretation in which the noun phrase *Jan* and the subject pronoun of the relative clause are coreferential.

- (503) [[Het gerucht over Jan]<sub>i</sub> [dat<sub>i</sub> hij t<sub>i</sub> het leukst vond]] was  
 the rumor about Jan which he the funniest considered was  
 dat hij opgegeten was door een leeuw.  
 that he prt.-eaten was by a lion  
 'The rumor about Jan that he liked best was that he had ben eaten by a lion.'

The examples in this section lead to a somewhat ambivalent result: connectivity effects can be established for examples such as (500) and (501) involving binding condition A and the bound variable reading of pronouns, but not for examples like (503) involving binding condition C. This may lead to the conclusion that connectivity effects only occur in the case of local (clause-internal and NP-internal) syntactic dependencies. This may in fact be derived from the traditional view in generative grammar, currently embedded in Chomsky's (2008) phase theory, that there are no syntactic restrictions on non-local relationships. It should be noted, however, that such a conclusion may be problematic in view Salzmann's (2006: Section 2.2) observation that connectivity effects differ crucially from reconstruction effects in that the latter also occur with non-local restrictions.

### C. Summary and concluding remarks

In the theoretical literature of the last decade an ardent debate has been raging on the question as to whether the connectivity effects in relative clauses can be reduced to reconstruction. This debate finds its origin in Vergnaud (1974), where it was claimed that, descriptively speaking, the antecedent of the relative pronoun is base-generated within the relative clause, placed in initial position of the relative clause by means of *wh*-movement, and subsequently raised to its surface position in the main clause; for updated versions of this so-called promotion/raising analysis, we refer the reader to Kayne (1994), Bianchi (1999) and De Vries (2002). Despite its popularity, the promotion/raising analysis is not uncontroversial as it raises a large number of technical/theory-internal problems; cf. Boef (2013) for a recent review. For example, it is still not clear why the antecedent is able to strand prepositions under *wh*-movement, while this is normally impossible in run-of-the-mill cases of *wh*-movement like topicalization and question formation; see the contrast between the (a)- and (b)-examples in (504).

- (504) a. \*?Dat boek heb ik lang naar gezocht. [topicalization]  
 that book have I long for looked
- a'. \*Wat heb je lang naar gezocht? [question formation]  
 what have you long for looked
- b. [Dat boek waar ik lang naar gezocht heb] is terecht. [Relativization]  
 that book where I long for looked have is found  
 'That book which I have been looking for a long time has been found.'

Furthermore, Salzmann (2006) points out that the differences between reconstruction and connectivity effects for binding conditions B and C discussed in this section are problematic for this analysis.

### V. Conclusion

This section has discussed reconstruction effects for constructions derived by *wh*-movement. It has been shown that these effects can be detected in topicalization constructions, *wh*-questions and relative clauses. The results are given in Table 2; the question marks indicate that for independent reasons, reconstruction effects for binding condition A/B could not be established for the construction in question.

Table 2: *Reconstruction and connectivity effects in wh-movement constructions*

	TOPICALIZATION	QUESTION FORMATION	RELATIVIZATION
BINDING CONDITION A	+	?	?
BOUND VARIABLE READING	+	+	+
BINDING CONDITION B	+	?	?
BINDING CONDITION C	+	—	—

We also discussed connectivity effects in contrastive left-dislocation and relative clause constructions, which are quite similar in nature to the reconstruction effects found in *wh*-movement constructions. The findings from this section are given in Table 3; the question mark indicates that for independent reasons the presence of connectivity effects for binding condition B could not be established.

Table 3: *Reconstruction and connectivity effects*

	RECONSTRUCTION EFFECT	CONNECTIVITY EFFECT
BINDING CONDITION A	+	+
BOUND VARIABLE READING	+	+
BINDING CONDITION B	+	?
BINDING CONDITION C	+	—

The similarities between reconstruction and connectivity effects have given rise to a revival of Vergnaud's (1974) promotion/raising analysis of relative clause constructions, according to which the antecedent of the relative pronoun is base-generated within the relative clause, moved into clause-initial position by *wh*-movement and subsequently promoted/raised into its surface position in the main clause; we refer to Kayne (1994), Bianchi (1999), De Vries (2002) for discussion.

An advantage of the promotion/raising analysis is that reconstruction and connectivity effects can both be derived from the copy theory of movement, according to which movement is a copy-and-paste operation that leaves a phonetically empty copy of the moved constituent in its original position; no additional theoretical machinery is needed. Salzmann (2006) objects to analyses of this sort by pointing out that they incorrectly predict that reconstruction and connectivity effects are identical: that this is not the case is clear from the fact that while reconstruction effects for binding condition C are pervasive, connectivity effects for binding condition C do not occur. We can add to this that the analysis wrongly predicts preposition stranding to be impossible, as run-of-the-mill cases of *wh*-movement like topicalization and question formation do not allow this.

A potential problem for Salzmann's claim is that connectivity effects for binding condition C (as well as for binding condition B) do occur in the case of contrastive left-dislocation, as is clear from the examples in (505), which were already discussed in Subsection II. This suggests that even if we reject the promotion/raising analysis for relative clauses, we may still need an analysis based on *wh*-movement for contrastive left-dislocation (which would again leave us with the problem of preposition stranding mentioned above); see Grohmann (2003:ch.4), De Vries (2009), and Ott (2014) for proposals that meet this condition; we return to this issue in Section 14.2.

- (505) a. \**Jan* bewondert *die jongen* het meest.  
 Jan admires that boy the most
- a'. \**Die jongen*<sub>i</sub>, *die*<sub>i</sub> bewondert *Jan* *t*<sub>i</sub> het meest.  
 that boy that admires Jan the most
- b. \**Jan* denkt [dat ik *die jongen* het meest bewonder].  
 Jan thinks that I that boy the most admire
- b'. \**Die jongen*<sub>i</sub>, *die*<sub>i</sub> denkt *Jan* [dat ik *t*<sub>i</sub> het meest bewonder].  
 that boy DEM thinks Jan that I the most admire

We have confined ourselves in this section to a discussion of reconstruction effects related to binding. Reconstruction effects are, however, also found in other domains; for a detailed discussion of these domains, we refer the reader to Sportiche (2006) and Salzmann (2006: Section 2.2).

### 11.3.7. Parasitic gaps

*Wh*-questions normally exhibit a one-to-one correspondence between *wh*-moved phrases and their traces. Subsection I below will show that in prototypical cases such as (506a) traces are bound by a unique *wh*-moved phrase; the *wh*-phrase *welke boeken* functions as the antecedent of the object gap indicated by the trace *t*. An example such as (506b) is an (apparent) exception to this otherwise robust generalization: the *wh*-phrase seems to function as the antecedent of both the object gap in the main clause and the object gap in the adverbial clause *zonder te lezen*. The formal linguistic literature refers to the interpretative gap in the adverbial clause as PARASITIC GAP (pg) for reasons that will become clear in subsection II.

- (506) a. Welke boeken heeft Jan  $t_i$  opgeborgen?  
 which books has Jan prt.-filed  
 ‘Which books has Jan filed?’  
 b. Welke boeken heeft Jan [zonder  $pg_i$  te lezen]  $t_i$  opgeborgen?  
 which books has Jan without to read prt.-filed  
 ‘Which book has Jan filed without reading?’

As parasitic gap constructions have been studied on the basis of English data especially, Subsection II introduces the notion of parasitic gap on the basis of a small number of English examples. This will result in a set of five restrictions that are commonly assumed to be applicable to them. These restrictions will be taken as the starting point of our discussion of Dutch parasitic gap constructions in Subsection III.

### *I. The bijection principle*

One of the hallmarks of *wh*-movement is that *wh*-phrases in clause-initial position are associated with a more deeply embedded interpretative gap, as indicated by the structures in (507a&b). Such structures can be used as input for the semantic component of the grammar and be translated into semantic representations with a question operator and a variable, as in the primed examples.

- (507) a. Wie<sub>*i*</sub> heeft Peter/hij  $t_i$  vandaag bezocht?  
 who has Peter/he today visited  
 ‘Who did Peter/he visit today?’  
 a'. ? $x$  (Peter/he visited  $x$  today)  
 b. Wie<sub>*i*</sub> heeft  $t_i$  Jan/hem vandaag bezocht?  
 who has Jan/him today visited  
 ‘Who visited Jan/him today?’  
 b'. ? $x$  ( $x$  visited Jan/him today)

There are several conditions on operator-variable representations in natural language that are not assumed for their counterparts in formal-logical systems. For example, while formal-logical systems allow vacuous quantifiers, that is, quantifiers that do not bind a variable, natural language does not. This can be seen as the result of a more general economy condition on natural language which prohibits superfluous elements in a representation: sentence (508a) is unacceptable despite the fact that a semanticist may consider its formal semantic counterpart in (508b) impeccable; cf. Chierchia & McConell-Ginet (1992:110).

- (508) a. \*Wie heeft Peter/hij Jan/hem vandaag bezocht?  
 who has Peter/he Jan/him today visited  
 b. ? $x$  (Peter/he visited Jan/him today)

Since a variable must be bound by an operator in order to form an interpretable sentence, the fact that the examples in (509) are uninterpretable does not come as a surprise; we will ignore the fact here that we do find constructions like (509a) in certain (e.g., generic) contexts that allow an implied theme argument and with pseudo-intransitive verbs, that is, verbs that take a cognate object.

- (509) a. \*Peter/hij heeft [e]<sub>object</sub> vandaag bezocht.  
           Peter/he has                   today    visited  
       b. \*Vandaag heeft [e]<sub>subject</sub> Jan/hem bezocht.  
           today    has                   Jan/him   visited

*Wh*-moved phrases further differ from semantic operators in that they can normally bind a single interpretative gap at most: a sentence like <sup>\$</sup>*Wie heeft onderzocht?* ‘Who has examined?’ cannot be assigned the meaning indicated by the well-formed semantic representation in (510b); the only way to express this meaning is by using a reflexive pronoun: *Wie heeft zichzelf onderzocht?* ‘Who has examined himself?’.

- (510) a. \*Wie<sub>i</sub> heeft t<sub>i</sub> [e]<sub>object</sub> onderzocht?  
           who has                           examined  
       b. ?x (x has examined x)

Koopman & Sportiche (1982) account for the observations above by postulating that natural language is subject to the bijection principle in (511); the specific phrasing of the principle is taken from Webelhuth (1992:143).

- (511)     • Bijection principle  
           a. Every syntactic operator binds exactly one syntactic variable.  
           b. Every syntactic variable is bound by exactly one syntactic operator.

## II. Some characteristic properties of parasitic gaps

This subsection discusses an (apparent) problem for clause (511a) of the bijection principle in the sense that a single *wh*-phrase is related to more than one interpretative gap. Such cases have been studied intensively for English since Engdahl’s (1983) seminal paper on this issue, but has received less attention in other languages. We will therefore introduce the notion of parasitic gap by using English examples. The results can then be used as a starting point for our description of Dutch in Subsection III. The discussion below is based on the more extensive review found in Culicover (2001).

A standard example of a parasitic gap construction from English is (512a); given that the two interpretative object gaps are translated as variables bound by the same question operator in the informal semantic representation in (512b), this example seems to violate clause (511a) of the bijection principle.

- (512) a. Which articles<sub>i</sub> did John file t<sub>i</sub> [without reading pg<sub>i</sub>]?  
           b. ?x (x:articles) (Jan filed x without reading x)

The use of a trace in the object position of the main clause in (512a) is motivated by the fact that it can be independently established that *wh*-movement is possible from this position; cf. *Which articles<sub>i</sub> did John file t<sub>i</sub>?* The reason for using the notion PARASITIC GAP (pg) for the interpretative gap in the adverbial phrase is twofold. First, example (513a) shows that it cannot be a trace left by *wh*-movement of *who*, as adverbial clauses are islands for *wh*-extraction. Second, example (513b) shows that it cannot occur if the direct object of the main clause occurs in its base-position; the gap is thus “parasitic” on *wh*-movement of this phrase.

- (513) a. \*Who<sub>i</sub> did John file the articles [without consulting t<sub>i</sub>]?  
 b. John filed a bunch of articles [without reading them/\*pg].

Parasitic gap constructions are not limited to *wh*-questions but also occur in other constructions derived by *wh*-movement. This is illustrated in example (514a) for a relative clause; examples (514b&c) show that *wh*-movement of the phonetically empty relative pronoun OP is possible from the object position of the relative clause but not from the object position of the adverbial clause. Note in passing that Engdahl assigns (514c) a question mark, while we use an asterisk: this is because Culicover (2001) simply calls this example ungrammatical.

- (514) a. Here is the paper<sub>i</sub> [OP<sub>i</sub> that John read t<sub>i</sub> [before filing pg<sub>i</sub>]].  
 b. Here is the paper<sub>i</sub> [OP<sub>i</sub> that John read t<sub>i</sub> [before filing his mail]].  
 c. \*Here is the paper<sub>i</sub> [OP<sub>i</sub> that John read his mail [before filing t<sub>i</sub>]].

Culicover (2001) provides a number of properties of parasitic gap constructions that are generally accepted, while noting that these claims have all been challenged in the literature at some point. An adapted version of his list is given as (515).

- (515) • Restrictions on English parasitic gap constructions
- a. Landing-site restriction: antecedents of parasitic gaps are in an A'-position.
  - b. Overt-movement restriction: antecedents of parasitic gaps are overtly moved.
  - c. Anti-c-command restriction: the trace of the antecedent of the parasitic gap and the parasitic gap do not c-command each other.
  - d. Categorical restriction: antecedents of parasitic gaps are noun phrases.
  - e. Multiple-island restriction: parasitic gaps and their antecedents cannot be separated by more than one island boundary.

Landing-site restriction (515a) refers to the fact that parasitic gap constructions typically occur in constructions derived by *wh*-movement; the English examples given above illustrate this point. This has led to the claim that the antecedent of the trace and the parasitic gap cannot be in an A-positions (that is, °argument positions to which thematic roles, agreement features and/or case are assigned) but must be in an A'-position, which may account for the fact that parasitic gaps may also occur in, e.g., English heavy NP-shift constructions. We will see, however, that this claim is not generally accepted for Dutch parasitic gap constructions.

The overt-movement restriction in (515b) is based on the standard generative assumption from the 1980's that *wh*-elements *in situ* undergo covert movement, that is, movement after the structure has been transferred to the phonological component of the grammar. Although this claim is no longer accepted by many generative linguists, the empirical issue still remains, which is that parasitic gaps cannot be licensed by *wh*-phrases occupying their base position; the *wh*-phrase *which article* in multiple question (516) does not license a parasitic gap. For convenience we will maintain the notion of overt-movement restriction without implying a specific stance on the issue of covert movement.

- (516) \*Who filed which articles [without reading pg<sub>i</sub>]?

The anti-c-command restriction in (515c) on the relation between the *wh*-trace and the parasitic gap can be derived from  $^{\circ}$ binding condition C, which forbids referential expressions to be A-bound, that is, to take a  $^{\circ}$ c-commanding antecedent in an argument position. This is done by extending to parasitic gaps the standard claim that *wh*-traces of nominal arguments exhibit the same binding behavior as referential expressions. The anti-c-command restriction can be used to account for the fact that subject traces block parasitic gaps more deeply embedded in their own clause, as illustrated by (517a&b), while traces left by *wh*-extraction of a subject from an embedded clause do not block parasitic gaps in matrix clauses, as illustrated by (517c). The examples are taken from Engdahl (1983) and Chomsky (1986); we will discuss a problem for the claim that *wh*-traces and parasitic gaps are subject to binding condition C in Subsection IIID, but we will accept this claim as a working hypothesis for what follows.

- (517) a. \*Which articles<sub>i</sub> [<sub>t<sub>i</sub></sub> got filed by John [without him reading pg<sub>i</sub>]]?  
 b. \*Who<sub>i</sub> [<sub>t<sub>i</sub></sub> met you [before you recognized pg<sub>i</sub>]]?  
 c. Which papers<sub>i</sub> did John decide [before reading pg<sub>i</sub>] to tell his secretary [<sub>t<sub>i</sub></sub> were unavailable]?

The anti-c-command restriction also predicts the acceptability of examples like (518a&b), which are again taken from Engdahl (1983) and Chomsky (1986). It also accounts for the fact illustrated in the primed examples that substituting a simple gap for the complex noun phrase *a picture of pg<sub>i</sub>* is impossible: because the two gaps are both A'-bound by the *wh*-phrase in clause-initial position and the first gap c-commands the second, the second gap is incorrectly A-bound by the first gap. Note that on the assumption that nominal *wh*-traces and parasitic gaps are both subject to binding condition C, this result follows regardless of whether the first or the second gap is considered to be parasitic on *wh*-movement; we therefore did not specify the nature of the gaps in the primed examples.

- (518) a. Which girl<sub>i</sub> did you show [a picture of pg<sub>i</sub>] to <sub>t<sub>i</sub></sub>?  
 a'. \*Which girl<sub>i</sub> did you show [e<sub>i</sub>] to [e<sub>i</sub>]?  
 b. Who<sub>i</sub> would [a picture of pg<sub>i</sub>] surprise <sub>t<sub>i</sub></sub>?  
 b'. \*Who<sub>i</sub> would [e<sub>i</sub>] surprise [e<sub>i</sub>]?

It should be noted that we can only maintain the anti-c-command restriction if we assume that the direct objects in (512)-(514) do not c-command the adjuncts containing the parasitic gaps. This assumption is consistent with the fact that complements are generated as the immediate sister of the selecting verb, but inconsistent with the c-command hierarchy that we introduced in Section N5.2.1.5, sub III; we refer the reader to the discussion of this issue in Contreras (1984), Koster (1987: Section 6.4) and Safir (1987), and to Lasnik (1999:ch.6) for a specific approach to English objects that may solve this problem.

Categorial restriction (515d), according to which the *wh*-moved phrase must be nominal, has been claimed not to be cross-linguistically valid but can at least be seen as a strong tendency in English: *wh*-movement of APs or PPs normally does not license parasitic gaps. Two examples adapted from Cinque (1990:115) are given in (519); see Koster (1987:156-7) for more examples.



- (519) a. \*How tired<sub>i</sub> can one feel  $t_i$  [without being pg<sub>i</sub>]?  
 b. \*[The man [to whom<sub>i</sub> I went  $t_i$  [without speaking pg<sub>i</sub>]] is there.

The examples above have shown that parasitic gaps are typically found in islands for *wh*-extraction, such as the adjuncts in (512) and (514) or the subject in (518b). Kayne (1984:ch.8) and Contreras (1984) have noted, however, that parasitic gaps cannot be embedded in islands *within an island*, as stated by the multiple-island restriction in (515e). This is illustrated by the contrasts in acceptability indicated in (520) and (521), in which the two (b)-examples should be construed as alternative realizations of the adverbial clauses in the (a)-examples, and the abbreviation OP again indicates the phonetically empty relative pronoun.

- (520) a. the person [OP<sub>i</sub> that John described  $t_i$  [adjunct ...]]  
 b. ?[adjunct without examining [object any pictures of pg<sub>i</sub>]].  
 b'. \*[adjunct without [subject any pictures of pg<sub>i</sub>] being on file].
- (521) a. the paper [OP<sub>i</sub> that we should destroy  $t_i$  [adjunct ...]]  
 b. ?[adjunct before someone steals [object a copy of pg<sub>i</sub>]].  
 b'. \*[adjunct before [subject a copy of pg<sub>i</sub>] gets stolen by someone].

Kayne detects a “sharp contrast” between the two alternative realizations of the adjunct clauses and attributes this to the fact that the parasitic gaps are embedded in a single (adjunct) island in the primeless (b)-examples but in two islands in the primed examples, an adjunct island and an additional subject island.

Now that we have briefly discussed the five restrictions in (515), we conclude our brief survey of English parasitic gaps by noting that Engdahl (1983) has found a great deal of variation in speakers’ judgments on parasitic gap constructions. Furthermore, it seems that the acceptability of parasitic gap constructions depends on the phrases they are embedded in; parasitic gaps in non-finite clauses such as (520b) are more likely to be accepted by speakers than parasitic gaps in finite clauses such as (521b). Or, stated somewhat differently, speakers who accept parasitic gaps in finite adjunct clauses such as (521b) will also accept them in non-finite adjunct clauses such as (520b), while the inverse does not necessarily hold. Engdahl’s hierarchy is given in a shorter and slightly adapted form as (522): it expresses that parasitic gaps are best in infinitival adjunct clauses, somewhat less favored in finite argument/adjunct clauses, and least favored in relative clauses.

- (522) *Accessibility hierarchy for occurrences of parasitic gaps* (simplified):  
 infinitival adjunct clause > finite argument clauses > finite adjunct clauses >  
 relative clauses

### III. Parasitic gaps in Dutch

Since Dutch parasitic gap constructions have received relatively little attention and since it is sometimes quite difficult to extract acceptability judgments from non-linguistic speakers, some of the acceptability judgments on the data below rely on our own intuitions; moreover, the attested variation in judgments implies that not all Dutch speakers will accept the judgments given here or elsewhere in the literature. The main point is, however, that many speakers do have the indicated contrasts between the examples in each set of examples. The reader is therefore requested to

interpret the judgments as statements about the *relative* acceptability of the examples in each given set (which actually also holds for all other judgments provided in this work). The following subsections deal with parasitic gap constructions we find or do not find in Dutch by means of a discussion of the five generalizations in (515).

A. *The landing-site and overt-movement restriction in (515a&b)*

Dutch and German data have given rise to an ardent debate about the landing-site restriction in (515a); this is related to the fact that parasitic gaps are not only licensed by *wh*-moved but also by scrambled phrases. It should be noted, however, that the debate is not only about the landing-site restriction as such, as it is intertwined with a much broader debate about the nature of scrambling: is it A- or A'-movement, or is it something totally different? In order to separate the two issues, we start by discussing some core data on parasitic gaps; this discussion will also touch upon the overt-movement restriction in (515b). After that, we continue with a brief discussion on the nature of scrambling, an issue discussed more extensively in Chapter 13. We will then introduce a test, based on binding, that can be used for discriminating between A- and A'-movement, which will be used in a more detailed discussion of the problematic scrambling data. Since we will see that there is no decisive argument against it, we will provisionally conclude that the landing-site restriction also applies to Dutch parasitic gap constructions. This does not imply that there are no problems left for this restriction, which we will demonstrate on the basis of passivized parasitic gap constructions.

1. *Some data*

Landing-site restriction (515a) correctly predicts that *wh*-moved phrases may serve as antecedents of parasitic gaps. This is illustrated in (523) for a *wh*-question, a topicalization construction, and a relative clause.

- (523) a. Welke boeken<sub>i</sub> heeft Jan [zonder pg<sub>i</sub> te lezen] t<sub>i</sub> opgeborgen?  
 which books has Jan without to read prt.-filed  
 'Which books has Jan filed without reading?'  
 b. Deze boeken<sub>i</sub> heeft Jan [zonder pg<sub>i</sub> te lezen] t<sub>i</sub> opgeborgen?  
 these books has Jan without to read prt.-filed  
 'These books, Jan has filed without reading.'  
 c. [De boeken [die<sub>i</sub> Jan [zonder pg<sub>i</sub> te lezen] t<sub>i</sub> opgeborgen heeft]] zijn weg.  
 the books which Jan without to read prt.-filed has are gone  
 'The books that Jan has filed without reading are missing.'

The overt-movement restriction in (515b), on the other hand, does not seem to hold for Dutch as the multiple *wh*-question in (524a) is fully acceptable. The situation is, however, more complex than it seems at first sight, as (524b) is unacceptable.

- (524) a. Wie heeft welke boeken<sub>i</sub> [zonder pg<sub>i</sub> te lezen] opgeborgen?  
 who has which books without to read prt.-filed  
 b. \*Wie heeft [zonder pg<sub>i</sub> te lezen] welke boeken<sub>i</sub> opgeborgen?  
 who has without to read which books prt.-filed

Since the position of the object in (524b) is taken to be its base position within the VP, we may assume that this is the construction that resembles the English multiple *wh*-question in (516) most closely. It seems that (524a) is derived from this structure by means of leftward movement of the object into some structurally higher position; more precise representations of the examples in (524) are thus as indicated in (525).

- (525) a. Wie heeft welke boeken<sub>i</sub> [zonder pg<sub>i</sub> te lezen] [<sub>VP</sub> t<sub>i</sub> opgeborgen]? [= (524a)]  
 who has which books without to read prt.-filed
- b. \*Wie heeft [zonder pg<sub>i</sub> te lezen] [<sub>VP</sub> welke boeken<sub>i</sub> opgeborgen]? [= (524b)]  
 who has without to read which books prt.-filed

The leftward movement of the object in (525a) is known as scrambling, and the non-interrogative counterparts of the examples in (525) given in (526) show that scrambling is indeed able to license parasitic gaps; cf. Bennis & Hoekstra (1984).

- (526) a. Jan heeft die boeken<sub>i</sub> [zonder pg<sub>i</sub> te lezen] [<sub>VP</sub> t<sub>i</sub> opgeborgen]?  
 Jan has those books without to read prt.-filed  
 'Jan has filed these books without reading them.'
- b. \*Jan heeft [zonder pg<sub>i</sub> te lezen] [<sub>VP</sub> die boeken<sub>i</sub> opgeborgen]?  
 Jan has without to read those books prt.-filed

The contrast between the (a)- and (b)-examples of (525) and (526) would follow from the landing-site and overt-movement restriction in (515a&b) if scrambling were an instance of A'-movement. The following subsection will show, however, that this is not easy to determine and that much depends on the specific version of the overall theory adopted.

The examples in (527) illustrate again that antecedents of parasitic gaps can be scrambled or *wh*-moved phrases. These examples also show that parasitic gaps easily alternate with overt referential personal pronouns if their antecedent is a scrambled phrase (see, e.g., Bennis & Hoekstra 1984 and Huybregts & Van Riemsdijk 1985), but that this is harder if the antecedent is interrogative; this holds especially if the *wh*-phrase is non-D-linked, which is the prototypical use of the interrogative pronoun *wat* 'what' (although it sometimes can get a D-linked reading in specific contexts which will be ignored here).

- (527) a. Jan heeft het boek<sub>i</sub>/het<sub>i</sub> [zonder pg<sub>i</sub>/het<sub>i</sub> te bekijken] t<sub>i</sub> weggelegd.  
 Jan has the book/it without pg/it to look.at away-put  
 'Jan has put the book/it away without looking at it.'
- b. Welke boek<sub>i</sub> heeft Jan [zonder pg<sub>i</sub>/<sup>?</sup>het<sub>i</sub> te bekijken] t<sub>i</sub> weggelegd?  
 which book has Jan without pg/it to look.at away-put  
 'Which book has Jan put away without looking at (it)?'
- b'. Wat<sub>i</sub> heeft Jan [zonder pg<sub>i</sub>/\*het<sub>i</sub> te bekijken] t<sub>i</sub> weggelegd?  
 what has Jan without pg/it to look.at away-put

To our knowledge the contrasts in acceptability between the three types of example in (527) has not been observed before. It seems plausible to relate the differences to the degree of referentiality of the antecedents of the parasitic gap; referential noun phrases and pronouns obviously have a high degree of referentiality, while D-linked

*wh*-phrases like *welke boeken* ‘which books’ and non-D-linked *wh*-pronouns like *wat* ‘what’ have an intermediate and a low degree of referentiality, respectively.

## 2. A theoretical intermezzo: scrambling and A- and A'-movement

The term SCRAMBLING refers to the fact that in certain languages the word order of constituents may vary, and for Dutch and German it is normally used to refer to certain changes in the word order of the middle field of the clause. The notion is somewhat misleading, however, as it suggests that it refers to a single operation with well-defined properties. Chapter 13 will show, however, that there are various types of operation with quite different properties that may affect the word order of the middle field of the clause: some have properties of A-movement while other have properties of A'-movement. But even if we restrict the notion of scrambling to leftward movement of nominal arguments (that is, subjects and objects), it is very difficult to determine definitively what type of movement we are dealing with, as this is closely related to the overall theory that one adopts. This subsection contains a brief theoretical digression in order to illustrate this.

The notion ARGUMENT POSITION (A-position) denotes positions in the clause that can be occupied by arguments of the verb only. Such positions are characterized by the fact that they can be assigned specific syntactic features, the three main types of which are: °thematic roles, structural °case and nominal agreement features (person, number, and gender). Prototypical A-positions are the subject and the object position. The notion NON-ARGUMENT POSITION (A'-position) denotes positions that can also be occupied by non-arguments (adverbial phrases, etc.). Such positions function as landing sites for elements with a specific logico-semantic role (such as operator or negation) or an information-structural function (topic, focus, etc.); a prototypical A'-position is the clause-initial position that can be filled by any clausal constituent as a result of *wh*-movement.

The number of A- and A'-positions postulated in generative grammar has increased considerably over the years. As for A-positions for nominal arguments of verbs, there were only two positions available in the early 1980's: the object and the subject position in the simplified structure in (528a). The object position within VP is the position to which the thematic role of theme, accusative case and (for languages that exhibit object agreement) object agreement features can be assigned; the subject position is the position to which the thematic role of agent, nominative case and the subject agreement features can be assigned. Arguments can sometimes also pick up their features in different places; in the °unaccusative construction in (528b) the subject *John* is base-generated in the object position, where it is assigned the thematic role theme, and subsequently moved into the subject position, where it is assigned nominative case and the subject agreement features.

- (528) a. [<sub>S</sub> John T(ense) [<sub>VP</sub> buys the book]].  
 b. [<sub>S</sub> John<sub>i</sub> T(ense) [<sub>VP</sub> t<sub>i</sub> leaves]].

Given that the object and subject positions exhaust the A-positions postulated it is a virtual necessity to assume that scrambling is A'-movement targetings some A'-position in the middle field of the clause. It is therefore not surprising that an early article such as Bennis and Hoekstra (1984) arrives at this conclusion.

The fact illustrated in (528b) that the syntactic features of a certain argument can be scattered over more than one position within the clause has ultimately given rise to the hypothesis that there is a one-to-one relationship between features and positions. For example, instead of assuming that all features for the direct object are generated in a single position, it is now generally assumed that these are assigned by different functional heads like those indicated by capitals in (529) to their complement or specifier: the main verb assigns the role theme, the AGR-head assigns the agreement features and the CASE-head assigns accusative case. Something similar is assumed for subjects. Note that the names used in (529) for these functional heads are just randomly chosen. Given that a large number of implementations of the main idea can be found in the literature since Pollock's (1989) seminal paper on this issue.

(529) [XP [accusative] CASE [AGR<sub>NP</sub> [person, number, gender] AGR [V<sub>VP</sub> V theme]]]

Since all A-positions in (529) are potential landing sites for the theme argument, it will be clear that the number of potential A-movements in the derivation of sentences has vastly increased compared to the earlier proposal in (528); the same holds in fact for verb movement, as all functional heads in (529) are assumed to be potential landing sites for the verb. This makes it possible to analyze scrambling of nominal arguments as A-movement, the position taken in Broekhuis (2008/2011), who argues that the theme position in (529) is cross-linguistically the base position of the object, that the agreement features are located in the object position preceding the verb in clause-final position (which in earlier versions of the theory was considered to be the base position of the object in Dutch), and that scrambling of the object targets the accusative position.

Since the seminal work by Haegeman & Zanuttini (1991), Haegeman (1995) and Rizzi (1996/1997), there has also been a proliferation of A'-positions; while in the early 1980's there was just one clearly defined A'-position, the landing site of *wh*-movement, more recent research claims to have identified a large number of additional A'-positions in structurally lower positions, which can be targeted by negative, focused, topical, quantified phrases, etc. Again, this makes it possible to analyze certain forms of scrambling (including those involving leftward movement of nominal arguments) as A'-movement. All of this implies that we cannot simply appeal to theory-internal considerations, but must develop empirical tests for supporting claims on the A- or A'-status of a specific form of scrambling.

### 3. Test for determining A- and A'-movement: Binding

We will use binding as a diagnostic tool in order to establish whether the object movement found in the scrambling variant of the parasitic gap construction should be considered A- or A'-movement, as these movement types can be shown to differ in whether or not they affect binding relations. We illustrate this by using English data in order not to bias our discussion of Dutch beforehand.

A'-movement does not alter binding options, as is clear from the examples in (530): the (a)-examples show that topicalization of the reflexive pronoun does not change its binding potential and the (b)-examples that topicalization of a potential antecedent does not create new binding possibilities. We refer the reader to Section

11.3.6 on reconstruction for a more extensive discussion as well as the relevant Dutch data.

- (530) a. *John* admires *himself* the most.  
 a'. *Himself*<sub>i</sub> *John* admires *t*<sub>i</sub> the most.  
 b. \*I believe *himself* to admire *Bill* the most.  
 b'. \**Bill*<sub>i</sub>, I believe *himself* to admire *t*<sub>i</sub> the most.

A-movement, on the other hand, does affect binding, as is clear from the subject raising examples in (531), taken from Den Dikken (1995); see Section 5.2.2.2 for an introduction to subject raising. The traces indicate the current standard analysis of examples of this sort: in (531a) the expletive *there* is raised from the subject position of the infinitival clause into the subject position of the matrix clause; in (531b), it is the noun phrase *some applicants* that is ultimately raised into the subject position of the clause. The crucial thing is that in (531a) the noun phrase *some applicants* is clearly located in the infinitival clause and therefore does not c-command the complement of the *to*-PP, the reciprocal *each other*, while in (531b) the noun phrase *some applicants* is moved into the subject position of the matrix clause and does c-command the reciprocal *each other* from this position. The acceptability contrast between the two examples thus shows that A-movement differs from A'-movement in that it does affect binding.

- (531) a. \**There*<sub>i</sub> seem to *each other* [*t*<sub>i</sub> to be *some applicants*<sub>i</sub> eligible to the job].  
 b. *Some applicants*<sub>i</sub> seem to *each other* [*t'*<sub>i</sub> to *t*<sub>i</sub> be eligible to the job].

The examples in (532) show essentially the same for the bound variable reading of referential pronouns: the quantifier in (532a) is embedded in the infinitival clause and therefore does not c-command the pronoun embedded in the complement of the *to*-PP, while the quantifier in (532b) is in the subject position of the matrix clause, from which it does c-command the pronoun. This accounts for the fact that the bound variable reading is only available in the latter case.

- (532) a. \**There*<sub>i</sub> seems to *his* mother [*t*<sub>i</sub> to be *someone* eligible for the job].  
 b. *Someone* seems to *his* mother [*t'*<sub>i</sub> to be *t*<sub>i</sub> eligible for the job].

#### 4. Empirical problems for the landing-site restriction: *Webelhuth's paradox*

The contrast between A- and A'-movement with respect to binding discussed in the previous subsection has played a major role in the discussion of the question as to whether scrambling of nominal arguments should be seen as A- or A'-movement, or perhaps even does not involve movement at all; a representative sample of these approaches can be found in Corver & Van Riemsdijk (1994).

Webelhuth (1989/1992) has argued that Dutch/German object scrambling exhibits properties of both A- and A'-movement in that object scrambling not only licenses parasitic gaps, but also feeds binding, a fact known as *Webelhuth's Paradox*. That object scrambling may license parasitic gaps was already illustrated in (526), and that it may also feed anaphor binding is illustrated in (533); cf. Vanden Wyngaerd (1988/1989). Note in passing that example (533a) seems to improve somewhat if the adverbial phrase *namens elkaar* 'on behalf of each other'



is assigned contrastive accent; we will ignore this effect here, which may indicate that (533a) is derived from (533b) by means of reconstructible focus movement.

- (533) a. \*Hij heeft namens *elkaar* *de jongens* bezocht.  
 he has on behalf of each other the boys visited  
 b. Hij heeft *de jongens*<sub>i</sub> namens *elkaar* *t<sub>i</sub>* bezocht.  
 he has the boys on behalf of each other visited  
 ‘He visited the boys on behalf of each other.’

Webelhuth’s crucial observation, illustrated by the German example in (534), is that scrambling can *simultaneously* feed binding and license a parasitic gap. The structure indicated is the one assigned by Webelhuth: the scrambled quantified direct/accusative object *jeden gast* binds the possessive pronoun embedded in the indirect/dative object *seinem Nachbarn* ‘his neighbor’, which licenses a bound variable reading, while it simultaneously licenses a parasitic gap. Such examples cannot be reproduced in Dutch because it does not easily allow inversion of indirect and direct objects in double object constructions.

- (534) Peter hat *jeden gast*<sub>i</sub> [ohne pg<sub>i</sub> anzuschauen] *seinem* Nachbarn vorgestellt.  
 Peter has each guest without to.look-at his neighbor introduced  
 ‘Peter introduced each guest to his neighbor without looking at him (each guest).’

Webelhuth assigns examples such as (534) a question mark, noting that they are “as good or as bad as” other parasitic gap constructions. He concludes from these examples that the dichotomy between A- and A’-positions is too coarse, and that we have to postulate a third, Janus-faced position that exhibits properties of both A- and A’-positions. This reasoning was sound at the time of Webelhuth’s publication, but the increase of A- and A’-positions that followed in the 1990’s allows a somewhat different view on examples of this kind: instead of assuming that the scrambled phrase is moved into its surface position in one fell swoop, we can now claim that it arrives there in a step-by-step fashion; see Mahajan (1990/1994) for early suggestions of this sort. This results in structures such as given in (535) with an additional trace *t’* added: if the first movement step is A-movement, the added trace is in an A-position and thus able to bind the reciprocal/possessive pronoun; if the second step is A’-movement, the scrambled phrase ends up in an A’-position, from which it can license the parasitic gap.

- (535) Peter hat *jeden gast*<sub>i</sub> [ohne pg<sub>i</sub> anzuschauen] *t’<sub>i</sub>* *seinem* Nachbarn *t<sub>i</sub>* vorgestellt.  
 Peter has each guest without to.look-at his neighbor introduced  
 ‘Peter introduced each guest to his neighbor without looking at him (each guest).’

Since it has generally been assumed since Chomsky (1986) that A’-movement cannot precede A-movement, a restriction which has become known as the BAN ON IMPROPER MOVEMENT, the proposed solution for Webelhuth’s paradox makes a very strong prediction: the phrase containing the parasitic gap must be in a structurally higher position than the phrase containing the A-bound pronoun. This does not seem easy to test, however. At first sight, the German example in (536a), taken from Mahajan (1990:60), seems to confirm this prediction: since the direct



object binds a parasitic gap, it must be in an A'-position and therefore cannot bind the possessive pronoun.

- (536) a. \*<sup>?</sup>Peter hat *jeden gast*<sub>i</sub> *seinem* Nachbarn [ohne pg<sub>i</sub> anzuschauen] t<sub>i</sub> vorgestellt.  
 Peter has each guest his neighbor without to look-at introduced
- b. \*<sup>?</sup>Peter hat *jeden gast*<sub>i</sub> *der Maria* [ohne pg<sub>i</sub> anzuschauen] t<sub>i</sub> vorgestellt.  
 Peter had each guest the Marie without to look-at introduced

It should be noted, however, that Müller & Sternefeld (1994) and Lee & Santorini (1994) claim that replacement of the indirect object *seinem Nachbarn* by an indirect object without a pronoun, such as *der Maria* in (536b), does not improve the result. This suggests that example (536a) is excluded for independent reasons and therefore does not bear on the issue under discussion. We cannot replicate the German data for Dutch double object constructions because indirect objects normally precede direct objects. But perhaps the examples in (537), in which the bound pronoun and the parasitic gap are both embedded in an adjunct, can be used to illustrate the same thing; note that the (b)-examples should be read as continuations of the (a)-example.

- (537) a. dat Jan de rivalen<sub>i</sub> ...  
 that Jan the rivals
- b. [zonder pg<sub>i</sub> aan te kijken] t'<sub>i</sub> namens elkaar t<sub>i</sub> feliciteert.  
 without prt. to look on.behalf.of each.other congratulates
- b'. ??namens elkaar t'<sub>i</sub> [zonder pg<sub>i</sub> aan te kijken] t<sub>i</sub> feliciteert.  
 on.behalf.of each.other without prt. to look congratulates

The judgments on these examples are somewhat problematic, however. First, we should note that Neeleman (1994a) gives the continuation in (537b') as acceptable, which means that the judgment given here is not uncontroversial. Second, we tend to think that this continuation only leads to a marginally acceptable result if the adverbial PP *namens elkaar* is followed by a brief intonation break. If so, the infinitival clause may be epenthetic and this would much complicate the analysis because it is often assumed that epenthetic phrases are clause-external. This means that the status of the continuation in (537b') is simply insufficiently clear, so that we cannot base any firm conclusion on this case. We therefore provisionally assume that the predictions that follow from the ban on improper movement are essentially correct until more conclusive counterevidence is provided.

Note that Neeleman provides example (537b') in order to argue that scrambling is in fact not a movement operation; he argues instead that scrambled phrases are base-generated in their surface position, as indicated in representation (538a): if true, this would imply that the landing-site and the overt-movement restriction should both be rejected. Neeleman claims that nominalizations such as (538b) also support the hypothesis that parasitic gaps can be licensed by noun phrases occupying their base-position: the noun phrase *boeken* is able to license the parasitic gap despite the fact that it is base-generated as the complement of the preposition *van*.

- (538) a. Jan bracht zijn boeken<sub>i</sub> [zonder pg<sub>i</sub> in te kijken] terug.  
 Jan brought his books without into to look back  
 ‘Jan brought his books back without looking into them.’
- b. het [zonder pg<sub>i</sub> in te kijken] terugbrengen van boeken<sub>i</sub>  
 the without into to look bring-back of books

Although this argument might have been sound in the early 1990’s, in more recent years it has been argued that there is much more movement within noun phrases than meets the eye; see Hoekstra (1999) for an analysis of this example that adopts the movement approach to parasitic gaps. It is therefore no longer evident that example (538b) provides evidence in favor of the base-generation approach to parasitic gaps; we will return to this approach in the next subsection, where it will be shown to have a serious empirical inadequacy.

##### 5. A final problem for the landing-site restriction: passive constructions

The previous subsection has shown that Webelhuth’s paradox receives a more or less natural explanation in the more recent versions of generative grammar that make more clause-internal A- and A’-positions available. There is, however, still a serious problem for landing-site restriction (515a), as various linguists have claimed independently of each other that parasitic gaps can occur in Dutch passive constructions. Broekhuis (1987/1992) claims that the result is somewhat less acceptable than in other cases but attributes this to the fact that the implied PRO-subject of the infinitival clause requires a controller (cf. Van Haaften 1991), as is clear from the fact illustrated in (539a) that the construction is also marked if the parasitic gap is replaced by an overt pronoun. De Hoop & Kosmeijer (1995) and Neeleman (1994a) give their examples as straightforwardly acceptable, which may be related to the fact that they include an agentive *door*-phrase, which may help to identify the implied PRO-subject; example (539b) shows that adding a *door*-phrase indeed improves the parasitic gap construction in (539a).

- (539) a. ?dat het boek<sub>i</sub> [zonder PRO ze<sub>i</sub>/pg<sub>i</sub> te bekijken] t<sub>i</sub> werd weggelegd.  
 that the book without them/pg to look.at was away-put  
 ‘that the book was put away without looking at it.’
- b. dat het boek<sub>i</sub> door Jan [zonder PRO pg<sub>i</sub> te bekijken] t<sub>i</sub> werd weggelegd.  
 that the book by Jan without to look.at was away-put  
 ‘that the book was put away by John without looking at it.’

To our knowledge, the consequences of the relative acceptability of the passive constructions in (539) have not yet been fleshed out. Broekhuis (1987/1992) suggests that the subject position is in fact not an A- but an A’-position in Dutch, which he supports by claiming that subjects of subject raising constructions such as (540a) are not able to bind (into) an indirect object of the matrix clause; cf. the discussion of the English examples in (531) and (532). Much rests on his claim that examples such as (540) are ungrammatical but this may be an overstatement; the judgments may simply not be clear enough to draw any firm conclusions.

- (540) a. <sup>?</sup>*Zij* leken elkaar/zichzelf [<sub>TP</sub> *t*<sub>i</sub> ziek te zijn].  
 they seems each.other/themselves ill to be  
 ‘They seemed to each other/themselves to be ill.’  
 b. <sup>?</sup>*Iedereen*<sub>i</sub> leek *zijn* moeder [<sub>TP</sub> *t*<sub>i</sub> de beste kandidaat te zijn].  
 everyone seemed his mother the best candidate to be  
 ‘Everyone seemed to his mother to be the best candidate.’

Another possibility, which has not been explored so far, is that the nominative noun phrase *die boeken* does not occupy the subject position at all in examples like (539). This is a plausible option because definite noun phrases can easily be shown not to occupy the regular subject position if they are part of the new information °focus of the clause. This is illustrated in (541a), which shows that the definite noun phrase need not be right-adjacent to the complementizer *dat* ‘that’ but may also occur in a more rightward position. That information structure is involved is clear from the fact that (phonetically reduced) referential subject pronouns, which are intrinsically part of the presupposition of the clause, do not have this option; cf. Section 13.2.

- (541) a. *dat* <de boeken> waarschijnlijk <de boeken> verkocht worden.  
 that the books probably sold are  
 ‘that the books probably are to be sold.’  
 b. *dat* <ze> waarschijnlijk <\*ze> verkocht worden.  
 that they probably sold are  
 ‘that they probably are to be sold.’

This would predict that the examples in (539) would become unacceptable if we substitute a referential pronoun for the noun phrase *die boeken* ‘those books’. It is not clear to us whether this prediction turns out to be true; although the examples in (542) may indeed be somewhat harder to interpret, this may simply be a side effect of the fact that they are given without an appropriate context.

- (542) a. <sup>??</sup>*dat ze*<sub>i</sub> [zonder PRO *pg*<sub>i</sub> te lezen] *t*<sub>i</sub> werden opgeborgen.  
 that they without to read were prt.-filed  
 ‘that they were filed without reading them.’  
 b. <sup>?</sup>*dat ze*<sub>i</sub> door Jan [zonder PRO *pg*<sub>i</sub> te lezen] *t*<sub>i</sub> werden opgeborgen.  
 that they by Jan without to read were prt.-filed  
 ‘that they were filed by Jan without reading them.’

De Hoop & Kosmeijer (1995) and Neeleman (1994a) claim that parasitic gaps can be licensed by an antecedent in an A-position, which amounts to saying that the landing-site restriction does not apply to Dutch. Their claim further implies that the standard assumption that parasitic gaps are subject to binding condition C should be replaced by the assumption that they are subject to binding condition A or B. The fact that the antecedent of a parasitic gap is external to the infinitival clause in (543) suggests that the parasitic gap is free in its local domain; it is therefore clear that parasitic gaps are not subject to binding condition A.

- (543) Subject<sub>i</sub> .... (door NP<sub>j</sub>) [zonder PRO<sub>j</sub> .... *pg*<sub>i</sub> .... te V<sub>infinitive</sub>] *t*<sub>i</sub> ... [passive]

The claim that the antecedent can be in an A-position thus inevitably leads to the conclusion that parasitic gaps are subject to binding condition B. This, in its turn, predicts that the antecedent of the parasitic gap may be bound by the subject of an (in)transitive matrix clause in the representation in (544a). We have not been able to construct such cases but this might be related to Van Haaften's claim that the implicit PRO-subject of the infinitival adjunct clause is normally controlled by the subject: if the subject controls PRO *and* binds the parasitic gap, this results in a violation of binding condition B because the parasitic gap would then *also* be bound within its local domain by the PRO-subject. A concrete example that illustrates this point is given in (544b).

- (544) a. \*[Subject<sub>i</sub> ... [zonder PRO<sub>i</sub> ... pg<sub>i</sub> ... te V<sub>infinitive</sub>] ...] [active]  
 b. Jan<sub>i</sub> werkte [zonder PRO<sub>i</sub> zichzelf<sub>i</sub>/\*pg<sub>i</sub> rust to gunnen].  
 Jan worked without himself/pg rest to allow  
 'Jan worked without allowing himself any rest.'

The claim that parasitic gaps are subject to binding condition B also predicts, however, that they behave like referential personal pronouns in that they can be bound by a nominal argument in some higher clause, but this is at odds with the contrast found in (545), which shows that while the referential personal pronoun *haar* 'her' can be bound by the subject of the highest clause, *Els*, the parasitic gap cannot; cf. Bennis (1986:55).

- (545) Els<sub>i</sub> zei [dat Jan<sub>j</sub> [zonder PRO<sub>j</sub> haar<sub>i</sub>/\*pg<sub>i</sub> te raadplegen] daartoe  
 Els said that Jan without her/pg to consult to.that  
 besloten had].  
 decided had  
 'Els said that Jan had decided that without consulting her.'

If we want to maintain that parasitic gaps are subject to binding condition B, we can only account for this contrast in a principled way by appealing to one of the other restrictions in (515). If we follow De Hoop & Kosmeijer (1995) in adopting the traditional claim that the gap of the infinitival clause is parasitic on some movement operation in the matrix clause, we can appeal to the anti-c-command restriction in (515c), which will be discussed in the next subsection. If we follow Neeleman's (1994a) base-generation approach, the overt movement and anti-c-command restriction are no longer applicable, while the categorial and island restriction are both satisfied; this approach therefore requires the introduction of some (yet unknown) *ad hoc* stipulation.

This subsection has discussed a final problem for the landing-site restriction by showing that the subject of Dutch passives can function as the antecedent of a parasitic gap. We have shown that if the antecedent of parasitic gaps can indeed be located in an A-position, the movement approach should be considered superior to a base-generation approach. We may also consider the possibility, however, that Dutch parasitic gaps are not true parasitic gaps, as has been proposed on other grounds for Dutch by Huybregts & van Riemsdijk (1985) as well as for German (see Culicover 2001 for references), but this seems less attractive because Dutch parasitic gaps seem to be well-behaved with respect to the other restrictions in

(515). Yet another possibility is that there is simply something special about the infinitival clauses in the passive constructions in (539), given that Van Haaften's (1991:108) comparable passive examples without a parasitic gap are all severely degraded regardless of the presence of a *door*-phrase; this is illustrated in (546b).

- (546) a. De politie<sub>i</sub> arresteerde mij [zonder PRO<sub>i</sub> zich<sub>i</sub> te legitimeren].  
the police arrested me without REFL to identify  
'The police arrested me without identifying themselves.'
- b. \*Ik werd (door de politie<sub>i</sub>) gearresteerd [zonder PRO<sub>i</sub> zich<sub>i</sub> te legitimeren].  
I was by the police arrested without REFL to identify

If the PRO-subject of an adverbial *zonder*-clause must indeed be controlled by the subject of the matrix clause, the examples in (539) are not only surprising because they violate the landing-site restriction, but also because they exhibit exceptional control behavior. This should make us cautious not to jump to far-reaching conclusions on the basis of these examples only.

Our discussion of parasitic gaps in passive constructions has not resulted in any clear conclusion but ended with a list of possible routes one might take to approach such examples. Since we have no further insights to offer at the moment, we leave this issue to future research.

### B. The anti-c-command restriction in (515c)

This subsection investigates the anti-c-command restriction, according to which the parasitic gap and the trace of its antecedent are not allowed to c-command each other. Subsection II has mentioned that Engdahl (1983) found that the acceptability of parasitic gap constructions depends on the nature of the clause embedding the parasitic gap, as expressed by the accessibility hierarchy in (547). Our discussion in the following subsections will follow this hierarchy with one divergence related to the fact that Engdahl's hierarchy is restricted to clauses: it does not include English cases such as *Who<sub>i</sub> would [a picture of pg<sub>i</sub>] surprise t<sub>i</sub>?* in which the parasitic gap is embedded in a noun phrase. We will discuss the Dutch counterpart of these examples before the discussion of parasitic gaps embedded in relative clauses.

- (547) *Accessibility hierarchy for occurrences of parasitic gaps* (simplified):  
infinitival adjunct clause > finite argument clauses > finite adjunct clauses >  
relative clauses

The discussion in the following subsections is greatly indebted to Bennis (1986:ch.1), which in its turn is based on earlier work of his with Teun Hoekstra (1984); Subsection 1 will include a discussion of an important restriction on Dutch parasitic gap constructions related to preposition stranding that is taken from this work.

#### 1. Parasitic gaps embedded in infinitival adjunct clause

All Dutch examples so far involve parasitic gaps embedded in an infinitival adjunct clause and this is not without reason: as stated by the accessibility hierarchy in (547), this is by far the easiest location to find parasitic gaps. We have seen that the antecedent of a parasitic gap can be a scrambled or a *wh*-moved phrase; this is

illustrated again by means of the examples in (548). Recall from Subsection A that parasitic gaps may alternate with overt pronouns in the scrambling case, but that this is less common in *wh*-constructions, especially if the *wh*-phrase is a non-D-linked pronoun such as *wat* 'what'. Since the reader may also want to have information on the distribution of the pronominal counterparts of parasitic gaps, we will often prefer scrambling constructions for illustration in what follows.

- (548) a. Jan heeft het boek<sub>i</sub> [zonder pg<sub>i</sub>/het<sub>i</sub> te bekijken] t<sub>i</sub> weggelegd.  
 Jan has the book without pg/it to look.at away-put  
 'Jan has put the book/it away without looking at it.'
- b. Welke boek<sub>i</sub> heeft Jan [zonder pg<sub>i</sub>/<sup>?</sup>het<sub>i</sub> te bekijken] t<sub>i</sub> weggelegd?  
 which book has Jan without pg/it to look.at away-put  
 'Which book has Jan put away without looking at (it)?'
- b'. Wat<sub>i</sub> heeft Jan [zonder pg<sub>i</sub>/\*het<sub>i</sub> te bekijken] t<sub>i</sub> weggelegd?  
 what has Jan without pg/it to look.at away-put

If we follow the standard assumption that the object traces in (548) are embedded within the VP while the adjunct clauses are located external to the VP, the acceptability of the parasitic gap constructions is expected as far as the anti-c-command restriction is concerned. The examples in the literature mostly involve cases in which the adjunct clause precedes the verb(s) in clause-final position. This raises the question as to what happens if such clauses are extraposed, that is, follow the verb(s) in clause-final position. Although speakers have varying judgments on the precise status of the parasitic gap constructions in (549), they generally agree that they are degraded compared to those in (548a&b); we should note, however, that Huybregts & van Riemsdijk (1985) give a similar example as fully acceptable.

- (549) a. Jan heeft die boeken<sub>i</sub> t<sub>i</sub> weggelegd [zonder ze<sub>v</sub>/<sup>?</sup>pg<sub>i</sub> te bekijken].  
 Jan has those books away-put without them/pg to look.at  
 'Jan has put the books away without looking at them.'
- b. Welke boeken<sub>i</sub> heeft Jan t<sub>i</sub> weggelegd [zonder ze<sub>v</sub>/<sup>?</sup>pg<sub>i</sub> te bekijken]?  
 which books has Jan away-put without them/pg to look.at  
 'Which books has Jan put away without looking at them?'

On the assumption that the difference in word order corresponds to a difference in structure, it seems feasible to account for the differences in judgment by appealing to the anti-c-command restriction. This may also account for the fact that acceptability contrasts such as indicated in (548b) and (549b) have not been reported for English; that parasitic gaps and referential pronouns are assumed to alternate freely may be due to the fact that often it cannot immediately be observed from the linear order of the utterances in this language whether or not extraposition has occurred. We leave exploration of this suggestion to future research; we will briefly return to extraposition in Subsections 2 and 3.

The anti-c-command restriction also predicts that parasitic gaps in infinitival adjunct clauses cannot be licensed by the subject of the first higher matrix clause. Subsection A5 has already shown that it is very difficult to test this prediction because parasitic gaps are excluded in such constructions for independent reasons: the discussion of (544) has shown that PRO-subjects of infinitival adjunct clauses

are normally controlled by the subject of the matrix clause and that parasitic gaps are consequently excluded because they would be locally bound by PRO. The anti-c-command restriction can, however, easily be demonstrated by examples in which the antecedent of the parasitic gap is a nominal argument in some higher clause; this was already shown for a subject in (545) and illustrated again for a direct object in (550).

- (550) Ik vertelde Els<sub>i</sub> [dat Jan<sub>j</sub> [zonder PRO<sub>j</sub> haar<sub>i</sub>/\*pg<sub>i</sub> te consulteren] daartoe  
 I told Els that Jan without her/pg to consult to.that  
 besloten had].  
 decided had  
 ‘I told Els that Jan had decided that without consulting her.’

Although parasitic gaps are virtually perfect in infinitival adjunct clauses (and even preferred to overt pronouns in *wh*-questions), they are less common in Dutch than in English. The cause of this is that Dutch differs from English in not allowing preposition stranding by extraction of a noun phrase or a pronoun; cf. (551b). Preposition stranding arises only as a result of °R-extraction from pronominalized PPs such as *er/daar/waar/...* + P ‘P it/that/what’; cf. (551c). We refer the reader to Chapter P5 for detailed and more careful discussion.

- (551) a. Jan heeft op het boek gewacht.  
 Jan has for the book waited  
 ‘Jan has waited for the book.’  
 b. \*Welk boek<sub>i</sub>/Wat<sub>i</sub> heeft Jan [PP op t<sub>i</sub>] gewacht.  
 which book/what has Jan for waited  
 Intended meaning: ‘Which book/What has Jan waited for?’  
 c. Waar<sub>i</sub> heeft Jan [PP t<sub>i</sub> op] gewacht?  
 where has Jan for waited  
 ‘What has Jan waited for?’

The ban on preposition stranding by extraction of noun phrases and pronouns severely restricts the construction types in which parasitic gaps may occur; cf. Bennis (1986). First, R-pronouns such as *er/daar/waar/...* are not able to act as antecedents of parasitic gaps in nominal argument position, as illustrated by the (a)-examples in (552). Second, noun phrases and pronouns are not able to license parasitic gaps in PPs, as illustrated by the (b)-examples. Acceptable results arise only if a noun phrase or pronoun licenses a parasitic gap in a nominal argument position, as in all examples given earlier, or if an R-pronoun licenses a parasitic gap within a PP, as illustrated in the (c)-examples.

- (552) a. Jan heeft [zonder het<sub>i</sub> te lezen] uit dit boek<sub>i</sub> geciteerd.  
 Jan has without it to read from this book cited  
 ‘Jan has quoted from this book without reading it.’  
 a'. Jan heeft daar<sub>i</sub> [zonder het<sub>i</sub>/\*pg<sub>i</sub> te lezen] [PP t<sub>i</sub> uit] geciteerd.  
 Jan has there without it/pg to read from cited



- b. Jan heeft [zonder [<sub>PP</sub> er<sub>i</sub> in] te kijken] het boek<sub>i</sub> besproken.  
 Jan has without there into to look the book reviewed  
 ‘Jan has reviewed the book without perusing it.’
- b'. Jan heeft het boek<sub>i</sub> [zonder [<sub>PP</sub> er<sub>i</sub>/\*pg<sub>i</sub> in] te kijken] besproken.  
 Jan has the book without there/pg into to look reviewed
- c. Jan heeft [zonder [<sub>PP</sub> er<sub>i</sub> in] te kijken] uit dit boek<sub>i</sub> geciteerd.  
 Jan has without there into to look from this book cited  
 ‘Jan has quoted from the book without glancing through it.’
- c'. Jan heeft daar<sub>i</sub> [zonder [<sub>PP</sub> er<sub>i</sub>/pg<sub>i</sub> in] te kijken] [<sub>PP</sub> t<sub>i</sub> uit] geciteerd.  
 Jan has there without there/pg into to look from cited

Because the unacceptability of the parasitic gap constructions in (552a'&b') is not due to problems with the anti-c-command restriction, we may conclude from examples like (545) and (550) that the anti-c-command restriction applies to Dutch in full force, ... provided that it should be possible for a parasitic gap to have an antecedent external to its minimal finite argument clause; this is the topic of the next subsection.

## 2. Parasitic gaps embedded in finite argument clauses

This subsection discusses parasitic gap constructions in which the parasitic gap has an antecedent external to its own minimal finite argument clause. The examples in (545) and (550) have already shown that the anti-c-command restriction (binding condition C) does not allow the subject/object of a matrix clause to function as the antecedent of a parasitic gap within an infinitival adjunct clause embedded in a finite complement clause. The same is shown in (553) for the somewhat simpler abstract structures in which the parasitic gap functions as a nominal argument of the finite argument clause itself; the primed examples provide concrete instantiations of these structures. We do not give similar cases in which the parasitic gap is embedded in a PP because the previous subsection has shown that noun phrases and pronouns cannot license such parasitic gaps.

- (553) a. \*NP<sub>i</sub> V ... [<sub>CP</sub> ... C [<sub>TP</sub> ... pg<sub>i</sub> ...]].  
 a'. Jan<sub>i</sub> vroeg Marie<sub>j</sub> [of zij<sub>j</sub> hem<sub>i</sub>/\*pg<sub>i</sub> een baan kon aanbieden].  
 Jan asked Marie if she him/pg a job could prt.-offer  
 ‘Jan asked Marie whether she could offer him a job.’
- b. \*NP<sub>i</sub> V ... NP<sub>j</sub> ... [<sub>CP</sub> ... C [<sub>TP</sub> ... pg<sub>j</sub> ...]].  
 b'. Marie<sub>i</sub> vertelde Jan<sub>j</sub> [dat zij<sub>j</sub> hem<sub>i</sub>/\*pg<sub>j</sub> een baan kon aanbieden].  
 Marie told Jan that she him/pg a job could offer  
 ‘Marie told Jan that she could offer him a job.’

In order to see whether an antecedent in a matrix clause can license a parasitic gap in a complement clause, we have to appeal to *wh*-moved complements of PPs (in order to avoid a violation of the anti-c-command restriction). Since nominal phrases cannot strand prepositions, we can confine our discussion to structures like (554a&b), in which some PP in the matrix clause has been split by R-extraction.

- (554) a. Waar<sub>i</sub> V ... [<sub>PP</sub> t<sub>i</sub> P] (V) [<sub>CP</sub> ... C [<sub>TP</sub> ... [<sub>PP</sub> P pg<sub>i</sub>] ...]]?  
 b. het boek<sub>i</sub> [waar<sub>i</sub> ... [<sub>PP</sub> t<sub>i</sub> P] V [<sub>CP</sub> ... C [<sub>TP</sub> ... [<sub>PP</sub> P pg<sub>i</sub>] ...]]]

The parasitic gaps in the structures in (554) are also embedded in a PP because the previous subsection has shown that R-pronouns cannot license parasitic gaps in nominal argument positions; that example (555) is not acceptable with a parasitic gap is thus expected.

- (555)    het boek<sub>i</sub> [waar<sub>i</sub> Jan [t<sub>i</sub> over] zei [dat hij het<sub>i</sub>/\*pg<sub>i</sub> zou kopen]]  
           the book where Jan about said that he it/pg would buy  
           ‘the book about which Jan said that he would buy it’

This leaves us with the option that a *wh*-moved R-pronoun binds a parasitic gap embedded in a PP. Bennis (1986) claims that such cases are indeed grammatical. His example is given as (556a); although we are not aware of any objections to his judgment in the literature, we assign to this example a percentage sign because we tend to think that the parasitic gap construction is marked compared to example (556b) with the overt R-pronoun *er*. Observe that the structure assigned to the parasitic gap construction in (556a) is quite different from what Bennis suggests; we return to the reason for this presently.

- (556)    Dit is het artikel<sub>i</sub> [waar<sub>i</sub> ik [t<sub>i</sub> over] zei ...  
           this is the article where I about said  
           ‘This is the article about which I said ...’  
   a.    %... [dat Harry een reactie [op pg<sub>i</sub>] moest schrijven]].  
           that Harry a reply to had.to write  
           ‘... that Harry had to write a reply to.’  
   b.    ... [dat Harry *er<sub>i</sub>* een reactie *op* moest schrijven]].  
           that Harry there a reply to had.to write  
           ‘... that Harry had to write a reply to.’

Another example with the abstract structure in (554b), taken from Huybregts & Van Riemsdijk (1985), is given as (557a). Although this example is given as fully grammatical, we again assigned it a percentage sign because it seems to be marked compared to the construction in (557b) with the overt R-pronoun *er*.

- (557)    Dit is een boek<sub>i</sub> [waar ik [t<sub>i</sub> van] denk ...  
           this is a book where I of think  
           ‘This is a book of which I think ...’  
   a.    %... [dat Jan al tijden [naar pg<sub>i</sub>] verlangt]].  
           that Jan already times for long  
           ‘... that Jan has longed for for ages.’  
   b.    ... [dat Jan *er* al tijden *naar*] verlangt]].  
           that Jan there already times for longs  
           ‘... that Jan has longed for it for ages.’

The contrasts we detect between the (a)- and (b)-continuations in (556) and (557) are not surprising in the light of Engdahl’s accessibility hierarchy in (547), according to which finite argument clauses are less amenable to parasitic gaps than infinitival adjunct clauses. It is important to note that we cannot account for these contrasts by appealing to the fact that finite argument clauses are generally extraposed; the fact that extraposition of infinitival adjunct clauses with a parasitic

gap in (549) has a degrading effect was claimed to be due to the anti-c-command restriction, but this restriction is satisfied in the parasitic gap constructions in (556a) and (557a).

If we follow Bennis (1986) and Huybregts & van Riemsdijk (1985) in assuming that the structures marked with a percentage sign are grammatical, we still have to deal with the question as to what the precise structure of these examples is. We already indicated that the structures that we have assigned to the parasitic gap constructions in (556a) and (557a) differ from the ones assumed in Bennis (1986). For theory-internal reasons, he claims that the trace is embedded in the finite clause, while the parasitic gap is embedded in the PP in the matrix clause, so that they should be switched in the examples (554) to (557) above. Although this claim is fully consistent with the anti-c-command restriction, we believe that there are compelling reasons for rejecting it.

First, it should be noted that *wh*-extraction of a relative pronoun from an embedded clause is possible but not greatly favored by many speakers; the percentage sign is used for sentence (558a) to indicate that many speakers prefer to use the resumptive prolepsis construction in (558b), which was discussed in Sections 11.3.1.3, sub VII, and 11.3.2, sub III. The crucial observation is that (558c) is completely unacceptable, which shows that *wh*-extraction is excluded in the resumptive prolepsis construction. The judgments on (558b&c) therefore strongly suggest that the corresponding parasitic gap construction should be analyzed as in (558d); the percentage sign indicates here that this example is less preferred than example (558b) with the R-pronoun *er*. Note that apart from the presence of the adverbial phrase *al tijden*, example (558b&d) are identical to (557a&b).

- (558) a. %het boek<sub>i</sub> [waar<sub>i</sub> ik denk [dat Peter [t<sub>i</sub> naar] verlangt]]  
 the book where I think that Peter for longs  
 ‘the book that I think that Peter longs for’
- b. het boek<sub>i</sub> [waar<sub>i</sub> ik [t<sub>i</sub> van] denk [dat Peter er<sub>i</sub> naar verlangt]]  
 the book where I of think that Peter there for longs  
 ‘the book which I think that Peter longs for’
- c. \*het boek<sub>i</sub> [waar<sub>i</sub> ik er<sub>i</sub> van denk [dat Peter [t<sub>i</sub> naar] verlangt]]  
 the book where I there of think that Peter for longs
- d. %het boek<sub>i</sub> [waar<sub>i</sub> ik [t<sub>i</sub> van] denk [dat Peter [pg<sub>i</sub> naar] verlangt]]  
 the book where I of think that Peter for longs  
 ‘the book which I think that Peter longs for’

This argument, which is taken from Huybregts & Van Riemsdijk, is not accepted by Bennis, who adopts the plausible assumption that the ungrammaticality of (558c) is the result of an intervention effect (cf. Section P5.5): he claims that an R-pronoun (here: *waar*) cannot be moved across another c-commanding R-pronoun (here: *er*). This intervention effect does not arise in the parasitic gap construction in (558d) because the main clause does not contain an R-pronoun; Bennis therefore concludes that the ungrammaticality of (558c) can be put aside as irrelevant.

A second objection to the claim that the trace is located in the embedded clause is that the parasitic gap construction is possible if the finite complement clause constitutes an island for *wh*-movement. Example (559a) first shows that *wh*-

extraction from an interrogative clause is impossible. Example (559b), on the other hand, is completely acceptable and the two competing analyses thus make sharply different predictions: the claim that the trace is located in the embedded clause wrongly predicts (559c) to have the same status as (559a), while the alternative analysis correctly predicts it to be as good or as bad as example (558d). Since, to our ear, the latter prediction is the correct one, we conclude that the structure indicated in (559c) is the correct one.

- (559) a. \*het boek<sub>i</sub> [waar<sub>i</sub> ik betwijfel [of Peter [<sub>t<sub>i</sub></sub> naar] verlangt]]  
 the book where I doubt if Peter for longs  
 ‘the book which I doubt that Peter longs for’
- b. het boek<sub>i</sub> [waar<sub>i</sub> ik [<sub>t<sub>i</sub></sub> van] betwijfel [of Peter er<sub>i</sub> naar verlangt]]  
 the book where I of doubt if Peter there for longs  
 ‘the book which I doubt that Peter longs for’
- c. %het boek<sub>i</sub> [waar<sub>i</sub> ik [<sub>t<sub>i</sub></sub> van] betwijfel [of Peter [pg<sub>i</sub> naar] verlangt]]  
 the book where I of doubt if Peter for longs  
 ‘the book which I doubt that Peter longs for’

The final argument against the claim that the trace is located in the embedded clause is that it does not seem to be possible to construct acceptable parasitic gap examples if the PP in the matrix clause cannot be pronominalized. We illustrate this by means of the examples in (560). First, observe that example (560a) is again dispreferred to the resumptive prolepsis construction, but it is possible, for which reason we assign it a percentage sign. Example (560b) is unacceptable because the *volgens*-PP does not allow R-pronominalization and R-extraction: the only option is pied piping as in *de man<sub>i</sub> [[volgens wie<sub>i</sub>] ik <sub>t<sub>j</sub></sub>] dacht [dat zij op hem<sub>i</sub> zou wachten]]* ‘the man according to whom I thought that she would what for him’. The fact that the heads of such PPs cannot be stranded should not affect the acceptability of the parasitic gap construction if the parasitic gap is located in the adjunct PP. The crucial example is therefore the parasitic gap construction in (560c). Since the claim that the trace is located in the embedded clause wrongly predicts it to have more or less the same status as (560a), we conclude that the structure indicated below is the correct one. For completeness’ sake example (560d) provides the preferred version of the relative clause, in which the relative pronoun pied pipes the preposition *volgens*.

- (560) a. %de man<sub>i</sub> [waar<sub>i</sub> ik dacht [dat zij [<sub>t<sub>i</sub></sub> op] zou wachten]]  
 the man where I thought that she for would wait  
 ‘the man whom I thought that she would wait for’
- b. \*de man<sub>i</sub> [waar<sub>i</sub> ik [volgens <sub>t<sub>i</sub></sub>] dacht [dat zij op hem<sub>i</sub> zou wachten]]  
 the man where I according.to thought that she for him would wait
- c. \*de man<sub>i</sub> [waar<sub>i</sub> ik [volgens <sub>t<sub>i</sub></sub>] dacht [dat zij [pg<sub>i</sub> op] zou wachten]]  
 the man where I according.to thought that she for would wait

The relative acceptability of (559c) and the unacceptability of (560c) show that the proposal according to which the trace is located in the embedded clause and the parasitic gap is located in the PP embedded in the matrix clause cannot be maintained because this wrongly predicts that these examples should have a similar

status as the corresponding (a)-examples; we therefore adopt the alternative proposal that the PP in the matrix clause hosts the trace of the moved constituent while the parasitic gap is located in the finite argument clause; this correctly predicts the (c)-examples to have a similar status as the corresponding (b)-examples.

### 3. Parasitic gaps embedded in finite adjunct clauses

Bennis (1986) claims that parasitic gaps cannot be embedded in finite adjunct clauses; two of his examples are given in a slightly adapted form in (561). This claim would be in line with Engdahl's accessibility hierarchy in (547) according to which parasitic gaps are less common in finite adjunct clauses than in finite argument clauses: because the previous subsection has shown that parasitic gaps are marked in Dutch adjunct clauses, it is to be expected that they give rise to even more degraded results in finite clauses.

- (561) a. Welk boek<sub>i</sub> moest Jan t<sub>i</sub> terugbrengen [voordat hij het<sub>i</sub>/\*pg<sub>i</sub> kon uitlezen]?  
 which book must Jan back-bring before he it/pg could prt-read  
 'Which book did Jan have to bring back before he could finish reading?'  
 b. Welk voedsel<sub>i</sub> moet je t<sub>i</sub> koken [voordat je het<sub>i</sub>/\*pg<sub>i</sub> opeet]?  
 which food must you cook before one it/pg up-eats  
 'Which food do you have to cook before you eat it?'

It should be noted, however, that examples such as (561) are not suitable for showing that parasitic gaps cannot occur in finite adjunct clauses. The reason is that they are in extraposed position and we have seen that this also has a degrading effect on the acceptability of infinitival adjunct clauses: as we attributed this to the anti-c-command restriction, the unacceptability of the parasitic gap constructions in (561) may simply provide additional support for this restriction. In order to conclusively show that parasitic gaps cannot occur in finite adjunct clauses, the adjunct clause must be in the middle field of the clause, as in (562). As this does not seem to improve the parasitic gap constructions, we may indeed safely conclude that parasitic gaps cannot be embedded in finite adjunct clauses.

- (562) a. Welk boek<sub>i</sub> moest Jan [voordat hij het<sub>i</sub>/\*pg<sub>i</sub> kon lezen] t<sub>i</sub> terugbrengen.  
 which book must Jan before he it/pg could read] back-bring  
 'Which book did Jan have to bring back before he could read it?'  
 b. Welk voedsel<sub>i</sub> moet je [voordat je het<sub>i</sub>/\*pg<sub>i</sub> eet] t<sub>i</sub> koken.  
 which food must you before you it/pg eat cook  
 'Which food do you have to cook before you eat it?'

Because the parasitic gap constructions in (562) do satisfy the anti-c-command restriction, their unacceptability must be due to some other restriction. Since the other restrictions in (515) are also satisfied, some additional constraint is needed; we refer the reader to Bennis (1986:48ff.) for a proposal embedded in terms of Kayne's (1984) path theory.

4. Parasitic gaps embedded in postnominal PPs

This subsection discusses cases in which a parasitic gap is embedded in a postnominal PP. A prototypical English example is given in (563a). Its contrast in acceptability with example (563b) again illustrates the effect of the anti-c-command restriction: since the object trace in (563a) does not c-command the subject position, the parasitic gap embedded in the subject can be licensed by *wh*-movement of the object; since the subject does c-command the object position, the parasitic gap embedded in the object cannot be licensed by *wh*-movement of the subject. On the assumption that direct objects function as external arguments of °complementives, the anti-c-command restriction also correctly predicts that a parasitic gap embedded in an object can be licensed by *wh*-movement of the nominal complement of a complementive PP; this is illustrated in (563c), where the label SC stands for small clause, that is, the phrase containing both the complementive and its logical °SUBJECT. An interesting feature of the acceptable parasitic gap constructions in (563a&c) is that they do not allow a bound pronoun in the position of the parasitic gap; this is illustrated in the primed examples. We refer to Engdahl (1983: Section 5) for a more extensive discussion of the English data.

- (563) a. Which girl<sub>i</sub> would [a picture of pg<sub>i</sub>] surprise t<sub>i</sub>?  
 a'. \*Which girl<sub>i</sub> would [a picture of her] surprise t<sub>i</sub>?  
 b. \*Which girl<sub>i</sub> t<sub>i</sub> sent [a picture of pg<sub>i</sub>] to Peter?  
 b'. Which girl<sub>i</sub> t<sub>i</sub> sent [a picture of her(*self*)] to Peter?  
 c. Which girl<sub>i</sub> did you send [<sub>sc</sub> [a picture of pg<sub>i</sub>] [to t<sub>i</sub>]]?  
 c'. \*Which girl<sub>i</sub> did you send [<sub>sc</sub> [a picture of her] [to t<sub>i</sub>]]?

Constructions like (563) are largely ignored in the literature on Dutch. Parasitic gap constructions of the form in (563a) are of course expected not to arise in Dutch, due to the earlier established fact that noun phrases cannot bind parasitic gaps embedded in PPs; this correctly predicts that example (564a) is excluded. Parasitic gaps are expected to be possible, however, if the *wh*-moved phrase is an R-pronoun, as in example (564b); the result is clearly not perfect but this example seems notably better than (564a). The two examples in (564a&b) are also noteworthy because they differ as to whether a bound pronoun can be used in the position of the parasitic gaps: this is possible only if the construction with a parasitic gap is fully unacceptable. The linear string in (564b') is acceptable, of course, but the crucial thing is that the *wh*-moved R-pronoun *waar* cannot be construed as the antecedent of the pronoun *haar* 'her'.

- (564) a. \*Welk meisj<sub>e</sub><sub>i</sub> zou [een foto van pg<sub>i</sub>] t<sub>i</sub> verrassen?  
 which girl would a picture of pg surprise  
 a'. <sup>?</sup>Welk meisj<sub>e</sub><sub>i</sub> zou [een foto van haar<sub>i</sub>] t<sub>i</sub> verrassen?  
 which girl would a picture of her surprise  
 b. <sup>?</sup>het meisj<sub>e</sub><sub>i</sub> [waar<sub>i</sub> [een vriend van pg<sub>i</sub>] [t<sub>i</sub> op] wacht]  
 the girl where a friend of for waits  
 'The girl who a friend of is waiting for.'  
 b'. \*het meisj<sub>e</sub><sub>i</sub> [waar<sub>i</sub> [een vriend van haar] [t<sub>i</sub> op] wacht]  
 the girl where a friend of her for waits

The anti-c-command restriction cannot be demonstrated by means of a Dutch version of (563b), because parasitic gaps embedded in a PP cannot be bound by a nominal argument in general. What we can show, however, is that parasitic gap can at least marginally be embedded in a direct object if an R-pronoun is extracted from a complementive PP; cf. (565a). Example (565b) shows again that the parasitic gap cannot be replaced by a bound pronoun: this example is acceptable only if the pronoun *haar* ‘her’ refers to some other person in the domain of discourse.

- (565) a. het meisje<sub>i</sub> [waar<sub>i</sub> ik [<sub>sc</sub> [een vriend van pg<sub>i</sub>] [<sub>t<sub>i</sub></sub> naartoe]] gestuurd heb]  
 the girl where I a friend of pg to sent have  
 ‘the girl that I have sent a friend of to’
- b. \*het meisje<sub>i</sub> [waar<sub>i</sub> ik [<sub>sc</sub> [een vriend van *haar*] [<sub>t<sub>i</sub></sub> naartoe]] gestuurd heb]  
 the girl where I a friend of her to sent have  
 ‘the girl that I have sent a friend of to’

This subsection has shown that Dutch at least marginally allows parasitic gaps in postnominal PPs if their antecedent is an R-pronoun. The restriction stated in the conditional part of the previous sentence makes it impossible to establish whether the anti-c-command restriction is applicable; we only have the weaker evidence that the marginally acceptable cases do not violate this restriction. It should further be noted that the marginally acceptable Dutch parasitic gap constructions are similar to their English counterparts in that the parasitic gaps cannot be replaced by bound pronouns.

### 5. Parasitic gaps embedded in relative clauses

Constructions in which a parasitic gap is embedded in a relative clause differ from those in which a parasitic gap is embedded in a postnominal PP in that they always give rise to an unacceptable result. This is illustrated in example (566), taken from Bennis (1986); the reader should ignore the pseudo-intransitive reading of *lezen* ‘to read’. The fact that these examples are not acceptable is in accordance with Engdahl’s accessibility hierarchy in (547); we refer the reader to Bennis (1986) for an account of these examples in terms of Kayne’s (1984) path theory.

- (566) a. \*Dit is het boek<sub>i</sub> [dat<sub>i</sub> [iedereen<sub>j</sub> [die<sub>j</sub> t<sub>j</sub> pg<sub>i</sub> leest]] t<sub>i</sub> bewondert].  
 this is the book which everyone who reads admires  
 Intended reading: ‘This is the book that everyone who reads it admires.’
- b. \*Dit is een vraag<sub>i</sub> [waar<sub>i</sub> [iedereen<sub>j</sub> [die<sub>j</sub> t<sub>i</sub> [pg<sub>i</sub> over] denkt]  
 this is a question where everyone who about thinks  
 een antwoord [t<sub>i</sub> op]] weet.  
 an answer to knows  
 ‘This is a question that everyone who thinks about it knows an answer to.’

### C. The categorial restriction in (515d)

Dutch is well-behaved with respect to the categorial restriction: only nominal phrases are able to license parasitic gaps, provided that we include the R-pronouns discussed in the previous section in the category of nominal elements. Engdahl (1983) found that PPs and APs can license parasitic gaps in Swedish. Since Cinque (1990:187, fn.9) observed that Engdahl’s cases all involve parasitic gaps in subjects



with a relative clause and that Dutch does not allow parasitic gaps in relative clauses, it should not be surprising that Engdahl's examples cannot be reproduced for Dutch. Moreover, constructing valid examples is somewhat delicate as it may be necessary that the trace and the parasitic gap have the same syntactic function (although Engdahl's PP-example does not satisfy this criterion). Example (567) therefore gives examples in which the PPs in the matrix and in the relative clause both function as prepositional objects. As expected the (b)-examples are unacceptable regardless of whether the moved phrase is a PP or an R-pronoun, with perhaps a minor contrast between the two cases.

- (567) a. Naar dit boek heeft iedereen [die ernaar verlangt] eerst  $t_i$  gekeken.  
 at this book has everyone who for.it longs first looked  
 'At this book everyone who longs for it has looked first.'
- b. \*Naar dit boek heeft iedereen [die  $pg_i$  verlangt] eerst  $t_i$  gekeken.  
 at this book has everyone who longs first looked
- b'. ??Daar heeft iedereen [die [ $pg_i$  naar] verlangt] eerst  $t_i$  [ $pg_i$  naar] gekeken.  
 there has everyone who to longs first at looked

Example (568) provides a Dutch example that corresponds structurally to Engdahl's Swedish AP-example. As expected, the parasitic gap is outright unacceptable.

- (568)  $Arm_i$  wil iemand [die  $dat_i$ /\* $pg_i$  ooit eerder geweest is]  
 poor wants someone who so/pg ever before been is  
 niet voor een tweede keer  $t_i$  worden.  
 not for a second time become  
 'Poor, someone who has ever been so before doesn't want to become a second time.'

In order to investigate the categorial restriction we therefore have to consider examples that do not involve a relative clause. In (569) we constructed such examples for complementive PPs. The two (b)-examples contrast sharply: *wh*-movement of the full PP does not, while *wh*-movement of an R-pronoun does license the parasitic gap.

- (569) a. In deze doos $_i$  heb ik [alvorens er de vaas in te stoppen]  
 in this box have I before there the vase into to put  
 een doek  $t_i$  gelegd.  
 a cloth put  
 'I have put a cloth in this box before putting the vase in it.'
- b. \*In deze doos $_i$  heb ik [alvorens de vaas  $pg_i$  te stoppen] een doek gelegd.  
 in this box have I before the vase to put a cloth put
- b'. Daar $_i$  heb ik [alvorens de vaas [ $t_i$  in] te stoppen] een doek [ $t_i$  in] gelegd.  
 there have I before the vase into to put a cloth into put  
 'I have put a cloth into it before putting the vase into it.'

Example (570) provides a similar case with a complementive AP, adapted from Cinque (1990); use of a parasitic gap gives rise to a degraded result.

- (570) Hoe moe<sub>i</sub> kan je je [zonder het/\*pg<sub>i</sub> te zijn] voelen?  
 how tired can one REFL without it/pg to be feel  
 ‘How tired can one feel without being it?’

Since we have not been able to construct any other acceptable cases with PPs and APs, we conclude that Dutch adheres to the categorial restriction. It must be noted, however, that there is one systematic exception illustrated in (571): argument clauses are able to license parasitic gaps.

- (571) [dat quarks bestaan]<sub>i</sub> heeft Gell-Mann [alvorens het<sub>i</sub>/pg<sub>i</sub> te kunnen bewijzen]  
 that quarks exist has Gell-Mann before it/pg to be.able prove  
 al  $t_i$  voorspeld.  
 already predicted  
 ‘That quarks exist, Gell-Mann already predicted before being able to prove it.’

The acceptability of examples of this type might be related to the fact that argument clauses can be pronominalized by means of the referential personal pronoun *het* ‘it’; we refer to Culicover (2001:54) for similar cases in English.

#### D. The multiple-island restriction in (515e)

The multiple-island restriction states that parasitic gaps can be separated from their antecedent by the boundary of at most one single island for *wh*-movement: if there is more than one boundary, parasitic gaps are impossible. That Dutch respects this restriction is clear from the examples in (572) to (574); see also Huybregts & Van Riemsdijk (1985). The examples in (572) first show that infinitival adjunct clauses are islands for *wh*-movement.

- (572) a. Jan vertrok [zonder/alvorens het boek te kopen].  
 Jan left without/before the book to buy  
 ‘Jan left without/before buying the book.’  
 b. \*Wat<sub>i</sub> vertrok Jan [zonder/alvorens  $t_i$  gekocht te hebben]?  
 what left Jan without/before bought to have

The examples in (573) illustrate again that parasitic gaps may occur within such infinitival adjunct islands: the antecedent of the parasitic gap, *het boek* ‘the boek’, is external to the adjunct clause.

- (573) Jan heeft het boek<sub>i</sub> [zonder/alvorens pg<sub>i</sub> te kopen]  $t_i$  bekeken.  
 Jan has the book without/before to buy looked.at  
 ‘Jan has looked at the book without/before buying it.’

Example (574a) shows that parasitic gaps are not possible if they are separated from their antecedent by two (or more) islands for *wh*-extraction. For completeness’ sake note that examples such as (574b) are irrelevant as the two infinitival clauses can easily be construed as separate adjuncts of the main clause; this is clear from the fact illustrated by (574b’) that the *alvorens*-clause can be topicalized without affecting the placement of the *zonder*-clause.

- (574) a. \*Jan heeft het boek<sub>i</sub> [alvorens [zonder pg<sub>i</sub> te kopen] te vertrekken] t<sub>i</sub> bekeken.  
 Jan has the book before without to buy to leave looked.at
- b. Jan heeft het boek [alvorens te vertrekken] [zonder pg<sub>i</sub> te kopen] t<sub>i</sub> bekeken  
 Jan has the book before to leave without to buy looked.at  
 ‘Jan has looked at the book without buying it before leaving.’
- b’. [Alvorens te vertrekken] heeft Jan het boek<sub>i</sub> [zonder pg<sub>i</sub> te kopen] t<sub>i</sub> bekeken.  
 before to leave has Jan the book before to leave looked.at  
 ‘Before leaving Jan has looked at the book without buying it.’

The unacceptability of (574a) has given rise to the claim that parasitic gaps are not base-generated as such but arise as the result of *wh*-movement of a phonetically empty operator; cf. Chomsky (1986: Section 10). A well-formed parasitic gap construction is claimed to have the structure in (575a); XP<sub>i</sub> does not bind the parasitic gap directly but this is mediated by the empty operator. The operator movement is motivated by the fact that the operator should be “sufficiently close” to its antecedent; informally speaking we can say that the operator must be in the initial position of a clause that is a clause mate of the prospective antecedent of the operator; a more semantic approach might claim that the movement of the empty operator creates an open proposition which can be saturated by XP<sub>i</sub>. The unacceptable cases in which the parasitic gap is separated from XP<sub>i</sub> by two boundaries for islands for *wh*-movement are assigned the representation in (575b); the reason for the ungrammaticality of this structure is that *wh*-movement of the empty operator crosses the boundary of an adjunct island for *wh*-movement.

- (575) a. ... XP<sub>i</sub> ... [<sub>ADJUNCT</sub> OP<sub>j</sub> ... pg<sub>j</sub> ...] t<sub>i</sub> ...  
 b. \*... XP<sub>i</sub> ... [<sub>ADJUNCT</sub> OP<sub>j</sub> ... [<sub>ADJUNCT</sub> ... pg<sub>j</sub> ...]] t<sub>i</sub> ...

A virtue of Chomsky’s analysis is that it derives the multiple-island restriction from the independently established fact about *wh*-movement that it is island-sensitive. It also solves the problem with the bijection principle discussed in Subsection I, as each interpretive gap in (575a) is associated with its own operator.

Another potential advantage of the empty operator analysis is that it solves a problem for the claim adopted earlier that *wh*-traces and parasitic gaps are subject to binding condition C, which was noted by Bennis (1986). For *wh*-traces the problem is illustrated in (576a), in which a reflexive is topicalized; the trace in this example is bound by the subject. Section 11.3.6 discussed this problem under the heading of reconstruction, which amounts to saying that traces are not subject to binding condition C but obey the same binding condition as their antecedent. If we assume the same for the parasitic gap in (576b) we do not have to be bothered about the fact that it is construed as coreferential with the subject in the matrix clause: the empty operator simply assumes the same properties as its antecedent *zichzelf* ‘himself’, and these are subsequently transferred to the parasitic gap. We therefore expect the parasitic gap to be bound by PRO, and since PRO is controlled by the subject of the matrix clause, it also follows that the parasitic gap is coreferential with the subject of the matrix clause .

- (576) a. *Zichzelf<sub>i</sub> vindt Peter t<sub>i</sub> erg dom.*  
 himself considers Peter very stupid  
 ‘Himself, Peter considers very stupid.’
- b. *Jan heeft zichzelf<sub>i</sub> [OP<sub>i</sub> zonder PRO pg<sub>i</sub> te bekijken] t<sub>i</sub> aangekleed.*  
 Jan has himself without to look.at prt.-dressed  
 ‘Jan has dressed without looking at himself.’

A potential drawback of the empty operator analysis is, however, that it cannot be applied to cases such as (577), in which the parasitic gap is embedded in a postnominal PP; cf. *Which girl<sub>i</sub> would a [picture of pg<sub>i</sub>] surprise t<sub>i</sub>?* Since Dutch noun phrases are normally not assumed to contain a landing site for *wh*-movement, we must maintain that the parasitic gap is base-generated in such structures, and the problem for the bijection principle remains.

- (577) ... XP<sub>i</sub> ... [NP ... N [P pg<sub>i</sub>]] ... t<sub>i</sub> ...

However, the proposed distinction between the constructions in (575a) and (577) may also have a positive side, as this may help to account for the fact that while the parasitic gap in (575a) can be replaced by an overt pronoun, this is impossible with the parasitic gap in (577); in the former case this simply involves substitution of a pronoun for the empty operator; a similar substitution for base-generated parasitic gaps may be impossible. Needless to say, of course, that this makes structures such as (577) no less mysterious.

#### IV. Conclusion

This section has discussed Dutch parasitic gap constructions on the basis of the five basic properties introduced in Subsection II, repeated here as (578). Although Culicover (2001) mentions that all restrictions have been challenged, it seems that Dutch is relatively well-behaved with respect to all of them.

- (578) • Restrictions on English parasitic gap constructions
- Landing-site restriction: antecedents of parasitic gaps are in an A'-position.
  - Overt-movement restriction: antecedents of parasitic gaps are overtly moved.
  - Anti-c-command restriction: the trace of the antecedent of the parasitic gap and the parasitic gap do not c-command each other.
  - Categorial restriction: antecedents of parasitic gaps are noun phrases.
  - Multiple-island restriction: antecedents of parasitic gaps and parasitic gaps cannot be separated by more than one island-boundary.

The landing-site restriction in (578a) has been challenged on the basis of Dutch scrambling data but the discussion seems to be more about the proper analysis of scrambling: is it A- or A'-movement, or a movement type with mixed properties? We have seen that current versions of generative grammar make a variety of A- and A'-positions available, which enables us to provide an account for most facts. These include those that motivated Webelhuth's paradox according to which scrambling targets a position with mixed A- and A'-properties, while maintaining the landing-site restriction in full force. Only the fact that several researchers have claimed that

subjects of passive clauses may license parasitic gaps has not yet been solved satisfactorily.

The overt-movement restriction in (578b) does not seem to meet any problem in Dutch: the base-generation approach to scrambling, which rejects this restriction, has been shown to run into a severe empirical problem.

The anti-c-command restriction in (578c) seems to be obeyed unconditionally in Dutch, although we have seen that the claim that this restriction can be derived from binding condition C should be somewhat relaxed in order to allow for certain reconstruction effects.

The categorial restriction in (578d) is normally obeyed as well, provided we take R-pronouns found in pronominalized PPs to be nominal in nature: a potential counterexample is that complement clauses can also license parasitic gaps.

The multiple-island restriction in (578e) also holds for Dutch. The restriction can easily be accounted for by following Chomsky (1986) in assuming that parasitic gaps are in fact *wh*-traces of phonetically empty operators which are *wh*-moved in order to be “sufficiently close” to their antecedents; the multiple-island restriction then follows from the fact that the *wh*-movement of the operator cannot cross islands. This leaves us with cases in which the parasitic gap is located in a postnominal PP: that such cases are different can possibly be motivated by the fact that they do not allow substitution of an overt pronoun for the parasitic gap.

This section cannot do justice to the vast literature on parasitic gaps in other languages or to the various theoretical approaches that have been proposed over the years. We therefore refer the reader to Culicover’s (2001) historical review, as well as the other contributions found in the volume on parasitic gaps collected in Culicover & Postal (2001). Important studies on parasitic gaps in Dutch (and German) are Bennis & Hoekstra (1984) and Huybregts & Van Riemsdijk (1985). The latter suggest an analysis that is radically different from the one taken as the point of departure in our description, but which was criticized on both empirical and theoretical grounds by Bennis (1986:ch.1) and Koster (1987:section 6.4). Another discussion that is highly relevant for Dutch can be found in Webelhuth (1989:ch.5). It seems that the interest in parasitic gap constructions has diminished since the early 1990’s; as far as we know, no ground-breaking insights have been gained since then.



## **Chapter 12 Word order in the clause IV: Postverbal field (extraposition)**

<b>Introduction</b>	<b>1542</b>
<b>12.1. General introduction</b>	<b>1543</b>
<b>12.2. Arguments, complementives and selected measure phrases</b>	<b>1550</b>
<b>12.3. Modifiers of the clause</b>	<b>1561</b>
<b>12.4. Parts of constituents</b>	<b>1570</b>
<b>12.5. Word order</b>	<b>1587</b>
<b>12.6. Bibliographical notes</b>	<b>1593</b>



**Introduction**

This chapter takes as its point of departure the discussion in 9.2, which has shown that finite verbs can be found in basically two positions: the clause-final position in embedded clauses and the verb-first/second position in main clauses; the latter position is normally occupied by a complementizer in embedded clauses.

- (1) a. Marie zegt [dat Jan het boek op dit moment *leest*].  
 Marie says that Jan the book at this moment reads  
 ‘Marie says that Jan is reading the book at this moment.’
- b. Op dit moment *leest* Jan het boek.  
 at this moment reads Jan the book  
 ‘At this moment, Jan is reading the book.’

On the basis of these two positions, the clause can be divided into various “topological” fields: the clause-initial position, the middle field and the postverbal field; cf. representation (2).

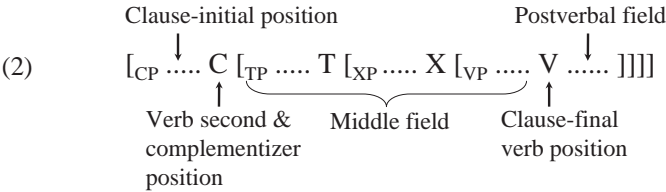

This chapter discusses the postverbal field, that is, the clause-internal constituents that follow the verb(s) in clause-final position. The postverbal field differs in various ways from the clause-initial position. For example, while the clause-initial position can be filled by a single constituent only, the postverbal field can contain more than one constituent.

- (3) a. Jan zal na zijn vakantie graag op Marie d’r kat passen.  
 Jan will after his vacation gladly after Marie her cat look  
 ‘Jan will be only too glad to look after Marie’s cat after his vacation.’
- b. Jan zal na zijn vakantie graag passen op Marie d’r kat.
- c. Jan zal op Marie d’r kat graag passen na zijn vakantie.
- d. Jan zal graag passen op Marie d’r kat na zijn vakantie.

Example (3a) shows that the postverbal field may remain empty; the PPs either occupy a position in the middle field of the clause or a position in the postverbal field. It seems that the question as to whether a clausal constituent can occur in the postverbal field is related to its categorial status. This is illustrated in (4) for direct objects: while nominal direct objects must precede the verb(s) in clause-final position, clausal direct objects normally follow them. The examples in (3) have already shown that. e.g., PP-complements like *op Marie d’r kat* can occur in both positions.

- (4) a. Jan heeft me zijn boek beloofd. [nominal direct object]  
 Jan has me his book promised  
 ‘Jan has promised me his book.’
- a’. \*Jan heeft me beloofd zijn boek.  
 Jan has me promised his book

- b. Jan heeft me beloofd [dat hij morgen komt]. [direct object clause]  
 Jan has me promised that he tomorrow comes  
 ‘Jan has promised me that he will come tomorrow.’
- b'. \*Jan heeft me [dat hij morgen komt] beloofd.  
 Jan has me that he tomorrow comes promised

The question as to whether or not a clausal constituent may/must occur in the postverbal field is also related to its syntactic function, as is clear from the fact that adverbial clauses differ from object clauses in that they may also occur in the middle field of the clause.

- (5) a. Jan zal [nadat hij uit Venetië terugkomt] op Marie d'r kat passen.  
 Jan will after he from Venice prt.-returns after Marie's cat look  
 ‘Jan will look after Marie's cat after he returns from Venice.’
- b. Jan zal op Marie d'r kat passen [nadat hij uit Venetië terugkomt].  
 Jan will after Marie's cat look after he from Venice prt.-returns

The examples in (6) show that the postverbal field is also accessible to specific *subparts* of clausal constituents. This holds, for instance, for postnominal modifiers of noun phrases; the associate noun phrase may function as an argument of the main verb but also as a subpart of an argument of the main verb. The discontinuous noun phrases are given in italics.

- (6) a. Jan heeft gisteren *een boek* gekocht *met prachtige foto's*.  
 Jan has yesterday a book bought with beautiful pictures  
 ‘Jan bought a book with beautiful pictures yesterday.’
- b. Jan heeft naar *een boek* gezocht *met foto's van katten*.  
 Jan has for a book looked with pictures of cats  
 ‘Jan has looked for a book with pictures of cats.’

The organization of this chapter is as follow. Section 12.1 starts with a discussion of some general properties of (elements occupying) the postverbal field. Section 12.2 discusses the restrictions on the placement of arguments and complementives in postverbal position; Section 12.3 does the same for adjuncts and Section 12.4 for subparts of clausal constituents. Section 12.5 concludes with a number of remarks on word order.

### 12.1. General introduction

This section deals with a number of general issues related to the postverbal field. Subsection I starts with a discussion of various differences between the postverbal field and the clause-initial position, the position that is the target of *wh*-movement. Subsection II shows that clausal constituents exhibit a different relative order in postverbal position than in the middle field. This so-called mirror effect will be used in Subsection III to argue that the postverbal field can also be filled in the absence of clause-final verbs. Subsection IV shows that we should distinguish various types of postverbal phrases: extraposed phrases, which are clearly clause-internal and will be the focus of this chapter, and right-dislocated phrases, for which it is not so

obvious that they are located clause-internally. Subsection V concludes with a discussion of the functional motivation for extraposition.

### *I. The clause-final field is accessible to more than one constituent*

The part of the clause preceding the finite verb in second position should be characterized as a *position* rather than as a *field*, as it can be occupied by a single constituent only; see Section 11.3 for extensive discussion. This clearly does not hold for the postverbal field, which can be occupied by an (in principle) indeterminate number of constituents; the primeless examples in (7) provide cases in which the number of postverbal constituents range from 0 to 2, and it is undoubtedly not difficult to construct or find examples with more than two postverbal constituents; the primed examples are added to show that there can be only one constituent in clause-initial position.

- (7) a. Jan zal na zijn vakantie graag op Marie d'r kat passen. [0]  
 Jan will after his vacation gladly after Marie her cat look  
 'Jan will be only too glad to look after Marie's cat after his vacation.'
- b. Jan zal na zijn vakantie graag passen op Marie d'r kat. [1]
- b'. Op Marie d'r kat zal Jan na zijn vakantie graag passen. [1]
- c. Jan zal graag op Marie d'r kat passen na zijn vakantie. [1]
- c'. Na zijn vakantie zal Jan graag op Marie d'r kat passen. [1]
- d. Jan zal graag passen op Marie d'r kat na zijn vakantie. [2]
- d'. \*Op Marie d'r kat na zijn vakantie zal Jan graag passen.
- d''. \*Na zijn vakantie op Marie d'r kat zal Jan graag passen.

In the early stages of generative grammar the examples in (7b-d) were derived from (7a) by a movement rule known as EXTRAPOSITION, which moves the PP from a preverbal position into the postverbal field. A problem for this proposal, which was already noted by Koster (1973), is that it is not in keeping with Emonds' (1976) STRUCTURE PRESERVATION PRINCIPLE, which requires movement to target an independently motivated position; this principle is satisfied by *wh*-movement, as there is clearly an identifiable clause-initial position, but this is not obviously the case for extraposition given that we are dealing with a *set* of positions; if the postverbal position of the phrases in (7) is indeed derived by movement, we may be dealing with a *set* of rules, which each may have their own properties. We will nevertheless stick to the notion of extraposition in order to refer to constructions with clause-internal postverbal constituents.

### *II. The mirror effect*

The primeless examples in (7) show that adverbial and argument PPs may occupy various positions in the clause: clause-initial, preverbal and postverbal. The examples in (8) further show that extraposition affects the linear order of these PPs: the (a)-examples first show that in the middle field of the clause adverbial PPs precede argument PPs as a rule (if the clause is pronounced with a neutral intonation pattern), while the (b)-examples show that in postverbal position the order is normally reversed; since Koster (1974) this phenomenon is often referred to as the MIRROR EFFECT.

- (8) a. Jan zal na zijn vakantie graag op Marie d'r kat passen. [adv > compl]  
 Jan will after his vacation gladly after Marie her cat look  
 'Jan will be only too glad to look after Marie's cat after his vacation.'
- a'. \*Jan zal graag op Marie d'r kat na zijn vakantie passen. [compl > adv]
- b. Jan zal graag passen op Marie d'r kat na zijn vakantie. [compl > adv]  
 Jan will gladly look after Marie her cat after his vacation  
 'Jan will be only too glad to look after Marie's cat after his vacation.'
- b'. \*Jan zal graag passen na zijn vakantie op Marie d'r kat. [adv > compl]

*III. The postverbal field can also be filled in the absence of clause-final verbs*

At first sight it may seem difficult to determine whether extraposition may also apply if the main verb occupies the verb-second position and there are consequently no verbs to be found in clause-final position. There are, however, various ways to establish this in an indirect way. First, we may appeal to the mirror effect discussed in the previous subsection: since the examples in (8) have shown that adverbial phrases precede PP-complements in the middle field of the clause but follow them in extraposed position, the acceptability of the word order in (9b) shows that at least the adverbial PP can be extraposed.

- (9) a. Jan past na zijn vakantie op Marie d'r kat. [non-extraposed]  
 Jan looks after his vacation after Marie her cat  
 'Jan will be looking after Marie's cat after his vacation.'
- b. Jan past op Marie d'r kat na zijn vakantie. [extraposed]  
 Jan looks after Marie her cat after his vacation  
 'Jan will be looking after Marie's cat after his vacation.'

Second, we may make use of the fact that certain elements, like complementives and verbal particles, are normally left-adjacent to the verb(s) in clause-final position. The primeless examples in (10) illustrate this by showing that, although the PPs in the primeless examples can be placed either in pre- or in postverbal position, they crucially cannot be located in the position indicated by the asterisk in between the complementive/particle and the clause-final main verb. From the fact that these PPs can follow the complementive/particle in the primed examples, we may again deduce that extraposition does not depend on the presence of a clause-final verb, but applies across-the-board; cf. Koster (1974).

- (10) a. Jan is <tijdens zijn vakantie> ziek <\*> geweest <tijdens zijn vakantie>.  
 Jan is during his vacation ill been  
 'Jan has been ill during his vacation.'
- a'. Jan was <tijdens zijn vakantie> ziek <tijdens zijn vakantie>.  
 Jan was during his vacation ill  
 'Jan was ill during his vacation.'
- b. De politie heeft Els <tijdens de rellen> op <\*> gepakt <tijdens de rellen>.  
 the police has Els during the riots prt. taken  
 'The police have arrested Els during the riots.'
- b'. De politie pakte Els <tijdens de rellen> op <tijdens de rellen>.  
 the police took Els during the riots prt.  
 'The police arrested Els during the riots.'

IV. *Not all postverbal elements are extraposed*

At first sight it seems relatively easy to establish whether a certain element is extraposed by considering its position with respect to the clause-final verb(s), complementives or particles. This, however, is only seemingly so as it is necessary to distinguish various types of postverbal constituents, which can easily be illustrated by means of the placement of noun phrases. Example (11a) first shows that nominal arguments cannot be extraposed: placing the nominal object *de directeur* to the right of the clause-final participle *gesproken* ‘spoken’ is excluded. The (b)-examples in (11) show, however, that placing this noun phrase to the right of the participle is possible if the regular object position is filled by some other noun phrase; the comma indicates that the postverbal noun phrase is generally preceded by an intonation break.

- (11) a. Ik heb gisteren <de directeur > gesproken <\*de directeur >.  
 I have yesterday the manager spoken  
 ‘I spoke to the manager yesterday.’
- b. Ik heb gisteren dhr. Jansen gesproken, de DIRECTEUR.  
 I have yesterday Mr Jansen spoken the manager  
 ‘I spoke to Mr Jansen yesterday, the manager.’
- b’. Ik heb dhr. Jansen/’m gisteren gesproken, de directeur.  
 I have Mr Jansen/him yesterday spoken the manager  
 ‘I spoke to Mr Jansen/him yesterday, the manager.’

The postverbal noun phrases in (b)-examples have properties different from run-of-the-mill extraposed phrases. The fact that the regular object position is filled by the noun phrase *dhr. Jansen*, for example, shows that the postverbal noun phrase is not selected by the verb but that, instead, we are dealing with a parenthetical constituent which is not an integral part of the clause; cf. Klein (1977) and De Vries (2009). This conclusion is supported by the fact that the postverbal noun phrase is separated from the preceding clause by an intonation break; this suggests that we are dealing with an apposition, that is, an addition intended to clarify some potential indistinctness in the preceding clause. Note that the postverbal noun phrase can be used to provide either discourse-new or discourse-old information. We will follow De Vries in referring to the former as AFTERTHOUGHT RIGHT-DISLOCATION and to the latter as BACKGROUNDING RIGHT-DISLOCATION; the two cases differ prosodically in that the former but not the latter is assigned accent, as is indicated by the small capitals in (11b).

Afterthoughts and backgrounded phrases can readily be recognized if they are associated with arguments, as these are normally obligatorily present. It is, however, harder if they are associated with optional constituents, such as the adverbial comitative *met*-PP in *dat Jan graag (met Peter) schaakt* ‘that Jan likes to play chess (with Peter)’. Examples such as (12), in which the adverbial *met*-PP is realized in the middle field of the clause, are of course straightforward: the postverbal *met*-PP can only be right-dislocated, as is also clear from the fact that it must be preceded by an intonation break.

- (12) a. \*dat Jan graag met hem schaakt met Peter. [no intonation break]  
 that Jan gladly with him plays.chess with Peter  
 b. dat Jan graag met hem schaakt, met PETER/Peter. [intonation break]  
 that Jan gladly with him plays.chess with Peter

If the preverbal adverbial PP is not present in the middle field, as in the examples in (13), we have to rely on intonation entirely. Recognizing an afterthought still seems relatively easy because it is signaled by an additional contrastive accent; furthermore, freestanding afterthoughts can often be preceded by appositional markers such as *en wel*. However, it can be quite difficult to distinguish an extraposed PP from a backgrounded PP as this crucially hinges on the intonation break, which can be quite difficult to detect in casual (fast) speech.

- (13) a. dat Jan graag schaakt met Peter.  
 that Jan gladly plays.chess with Peter  
 b. dat Jan graag schaakt, (en wel) met PETER.  
 that Jan gladly plays.chess and prt with Peter  
 c. dat Jan graag schaakt, met Peter.  
 that Jan gladly plays.chess with Peter

This makes distinguishing extraposition from backgrounding in constructions like (12) quite a delicate matter; our judgments on the examples given here and later in this chapter are based on our own intuitions as to whether an intonation break is needed, possible or obligatory in *slow, careful* speech. One fact that may help to distinguish extraposed from backgrounded phrases is that backgrounding right-dislocation does not affect the intonation contour of the clause. If the postverbal phrase is assigned (non-contrastive) sentence accent, as in (14a), we can safely conclude that we are dealing with extraposition (sentence accent is indicated by means of italics). However, if sentence accent is assigned to (some constituent preceding) the clause-final verb, as in (14b), it is again not evident whether we are dealing with extraposition or backgrounding. Afterthought right-dislocation in (14c) is again relatively easy to recognize: it does not affect the placement of the sentence accent and the afterthought itself is assigned an additional accent.

- (14) a. dat Jan graag schaakt met *Peter*. [extraposition]  
 that Jan gladly plays.chess with Peter  
 b. dat Jan graag *schaakt* met Peter. [extraposition/backgrounding]  
 that Jan gladly plays.chess with Peter  
 c. dat Jan graag *schaakt*, met PETER. [afterthought]  
 that Jan gladly plays.chess with Peter

A syntactic test that may be helpful in distinguishing the various types of postverbal phrases is VP-topicalization. The examples in (15a&b) show that run-of-the-mill extraposed constituents like clausal and prepositional direct objects are pied piped under VP-topicalization.

- (15) a. Jan heeft haar niet verteld dat hij gaat emigreren.  
 Jan has her not told that he goes emigrate  
 ‘Jan hasn’t told her that he is going to emigrate.’  
 a’. Verteld dat hij gaat emigreren heeft hij haar niet.  
 a’’. ??Verteld heeft hij haar niet dat hij gaat emigreren.  
 b. Jan heeft niet gewacht op toestemming.  
 Jan has not waited for permission  
 ‘Jan hasn’t waited for permission.’  
 b’. Gewacht op toestemming heeft Jan niet.  
 b’’. ??Gewacht heeft Jan niet op toestemming.

Stranding of clausal and prepositional direct objects is only possible if they are right-dislocated, that is, preceded by an intonation break. In the case of the clausal object, this is only fully acceptable if the anticipatory pronoun *het* is present (due to the fact that the verb *vertellen* ‘to tell’ requires a direct object) while in the case of the PP the anticipatory pronominal PP *er ... op* ‘for it’ may be absent (since *wachten* ‘to wait’ can also be used without a PP-complement).

- (16) a. Verteld heeft hij ??(het) haar niet, dat hij gaat emigreren.  
 told has he it her not that he goes emigrate  
 b. Gewacht heeft Jan (er) niet (op), op toestemming.  
 waited has Jan there not for for permission

The examples in (17) show that right-dislocated phrases do display a tendency to strand; the (b)-examples show that pied piping of afterthoughts requires us to use quite distinct/long intonation breaks (indicated by em-dashes), and even then some speakers tend to reject it; the (c)-examples show that pied piping of backgrounded phrases gives rise to a straightforwardly bad result. Stranding is easily possible in both cases.

- (17) a. Jan heeft nog nooit met hem geschaakt, met PETER/Peter.  
 Jan has yet never with him played.chess with Peter  
 ‘Jan has never played chess with him, with Peter.’  
 b. Met hem geschaakt heeft Jan nog nooit, met PETER.  
 b’. %Met hem geschaakt — met PETER— heeft Jan nog nooit.  
 c. Met hem geschaakt heeft Jan nog nooit, met Peter.  
 c’. \*?Met hem geschaakt, met Peter, heeft Jan nog nooit.

It is not a priori clear that the markedness of pied piping in (17c’) is syntactic in nature, as De Vries (2002:292) suggests that pied piping of backgrounded phrases may be incompatible with the focus/topic interpretation assigned to topicalized phrases. What is important for us at this stage is, however, that extraposed phrases seem to be preferably pied piped under VP-topicalization, while backgrounded right-dislocated phrases tend to be stranded, and that some speakers allow both options in the case of afterthoughts (given the right intonation contour).

This subsection has shown that it is often not possible to conclude on the basis of postverbal placement of a constituent alone that we are dealing with extraposition; we may also be dealing with, e.g., an afterthought or a backgrounded



phrase. Furthermore, distinguishing extraposition from backgrounded phrases may be hazardous as the intonation break that characterizes the latter can be quite difficult to detect in casual (fast) speech; we therefore have to appeal to our own intuition on the use of intonation breaks in slow, careful speech. Finally, we proposed VP-topicalization as a means of distinguishing extraposition from right-dislocation: extraposed phrases tend to be pied piped, while backgrounded phrases tend to be stranded under VP-topicalization. For a more detailed discussion of right dislocation, we refer the reader to Section 14.3.

V. Factors potentially favoring extraposition

If we put aside cases in which extraposition is impossible or obligatory, we have to raise the question as to what determines whether or not extraposition takes place. To our knowledge, this question has not received much attention in the literature so far. One factor that may play a role is information structure. That this is the case is suggested by the examples in (18). Although it is not easy to detect a clear meaning difference between the two orders in the active clause in (18a), the impersonal passive constructions in the (b)-examples show that the absence of expletive *er* has a degrading effect on extraposition if the middle field of the clause is empty. Because Bennis (1986) has shown that expletive *er* signals the absence of presuppositional material, the contrast between the two (b)-examples suggests that presuppositional material has to precede the clause-final verb, see also Haeseryn et al. (1997:1366). That extraposed phrases are part of the focus (new information) of the clause is supported by the fact that under a neutral, non-contrastive intonation pattern, they tend to receive sentence accent (indicated by italics); see also Zwart (2011:63-4).

- (18) a. dat Jan <op de *architect*> wacht <op de *architect*>.  
 that Jan for the architect waits  
 ‘that Jan is waiting for the architect.’
- b. dat er <op de *architect*> gewacht wordt <op de *architect*>.  
 that there for the architect waited is  
 ‘that the architect is being waited for.’
- b’. dat <op de architect> *gewacht* wordt <<sup>?</sup>op de architect>.  
 that for the architect waited is  
 ‘that the architect is waited for.’

Although example (18b) shows that PPs presenting discourse-new material can occur preverbally, there are cases in which discourse-new material must be extraposed. The examples in (19) illustrate this for an adverbial clause of reason. Although we have seen in examples (7) to (10) that adverbial clauses can occur in preverbal position, the clause in (19a&b) is preferably placed in clause-final position. This preference for extraposition may be due to prosodic reasons, as clauses and other long phrases give rise to an awkward intonation contour if they precede the clause-final verb(s); cf. Truckenbrodt (1995) and De Vries (2002:260). This holds especially if the clause immediately precedes a verb with sentence accent, as is clear from the fact that the result is much better in (19b’) in which the adverbial clause is followed by other material. This is a more general phenomenon;

we refer the reader to Haeseryn et al (1997:1366) for similar cases in which a clause immediately precedes a negative adverb *niet* with sentential stress.

- (19) a. dat Jan *vertrok* [omdat hij kwaad was].  
 that Jan left because he angry was  
 ‘that Jan left because he was angry.’  
 b. <sup>?</sup>dat Jan [omdat hij kwaad was] *vertrok*.  
 that Jan because he angry was left  
 b’. dat Jan [omdat hij kwaad was] onmiddellijk *vertrok*.  
 that Jan because he angry was immediately left

Another factor that may affect the placement of constituents that optionally undergo extraposition is related to processing: there is a tendency to minimize the distance between the finite verb in clause-initial position and the non-finite verb(s) in clause-final position and to reduce the complexity of the middle field. Extraposed material is therefore expected to be more frequently found in long and complex sentences; cf. Haeseryn et al. (1997).

## 12.2. Arguments, complementives and selected measure phrases

This section discusses extraposition of elements selected by main verbs. Subsection I starts by discussing the restrictions on extraposition of arguments: as a general rule extraposition is impossible with nominal arguments, obligatory with clausal arguments and optional with prepositional arguments. Subsection II will show that extraposition of <sup>o</sup>complementives is excluded, although there seem to be a number of (apparent) exceptions to this general rule. Subsection III discusses constructions with verbs like *duren* ‘to last’ and shows that measure phrases selected by these verbs cannot be extraposed either.

### I. Arguments

The examples in (20a&b) show that nominal arguments differ from clausal arguments in that the former must precede the clause-final verbs, whereas the latter normally follow them. Prepositional complements (including prepositional indirect objects) differ from both nominal and clausal arguments in that they may either precede or follow the clause-final verbs.

- (20) a. dat Jan me <het verhaal> vertelde <\*het verhaal>. [nominal complement]  
 that Jan me the story told  
 ‘that Jan told me the story.’  
 b. dat Jan me <\*dat zij komt> vertelde <dat zij komt>. [clausal complement]  
 that Jan me that she comes told  
 ‘that Jan told me that she’ll come.’  
 c. dat Jan me <over haar komst> vertelde <over haar komst>. [PP-compl.]  
 that Jan me about her arrival told  
 ‘that Jan told me about her arrival.’

A. Nominal arguments

Nominal arguments precede the verb(s) in clause-final position. This holds for subjects and direct objects alike, regardless of whether they are indefinite or definite.

- (21) a. dat er <iemand> om hulp riep <\*iemand>.
   
that there someone for help called
   
'that there was someone calling for help.'
- a'. dat <de jongen/Peter > om hulp riep <\*de jongen/Peter>.
   
that the boy/Peter for help called
   
'that the boy/Peter was calling for help.'
- b. dat Peter graag <iemand/zijn moeder> bezoekt <\*iemand/zijn moeder>.
   
that Peter gladly someone/his mother visits
   
'that Peter likes to visit someone/his mother.'

This restriction is especially clear in the case of indirect objects: while prepositional indirect objects can easily be extraposed, their nominal counterparts cannot. In order to eliminate possible interference of the presence of a direct object, the examples in (22) illustrate this by means of a regular passive construction.

- (22) a. Dat boek is (aan) Marie toegestuurd.
   
that book is to Marie prt.-sent
   
'That book has been sent to Marie.'
- b. Dat boek is toegestuurd \*(aan) Marie.
   
that book is prt.-sent to Marie
   
'That book has been sent to Marie.'

One apparent exception to the general rule that nominal arguments cannot be extraposed has already been discussed in Section 12.1, sub IV: afterthoughts and backgrounded noun phrases can be placed postverbally. We have seen, however, that these should not be considered extraposed phrases but that they are right-dislocated, parenthetical constituents. VP-topicalization can be used to support this view. The examples in (23) first show that a direct object must be pied piped under VP-topicalization if it is in its base-position; under neutral intonation (that is, without contrastive accent) the direct object can only be stranded if it is scrambled leftwards across the adverb *graag* 'gladly'.

- (23) a. Ik wil <de directeur> graag [<sub>VP</sub> <de directeur> spreken].
   
I want the manager gladly speak
   
'I'd like to speak to the manager.'
- b. De directeur spreken wil ik graag.
   
the manager speak want I gladly
- b'. Spreken wil ik <de directeur> graag <\*de directeur>.
   
speak want I the manager gladly

Example (24b) shows that right-dislocated noun phrases can easily be stranded in postverbal position, while the (c)-examples show that pied piping is only possible in the case of afterthoughts, in which case we have to use quite distinct intonation breaks—and even then some speakers tend to reject it.

- (24) a. Ik wil graag [<sub>VP</sub> dhr. Jansen spreken], de DIRECTEUR/directeur.  
I want gladly Mr Jansen speak the manager  
'I'd like to speak Mr Jansen, the manager.'
- b. Dhr. Jansen spreken wil ik graag, de DIRECTEUR/directeur.  
Mr Jansen speak want I gladly the manager
- c. <sup>%</sup>Dhr. Jansen spreken —de DIRECTEUR— wil ik graag.  
Mr Jansen speak the manager want I gladly
- c'. <sup>\*?</sup>Dhr. Jansen spreken, de directeur, wil ik graag.  
Mr Jansen speak the manager want I gladly

Enumerations, such as the one in example (25a), constitute another possible exception to the general rule that nominal arguments must precede the clause-final verbs; cf. Haeseryn et al. (1997:1376). Such enumerations are preceded by an intonation break and cannot be pied piped under VP-topicalization, which again suggests that they are parenthetical in nature: such examples are therefore special in that the “true” direct object does not have to be pronounced.

- (25) a. Ik moet (de volgende dingen) kopen: papier, potloden en een liniaal.  
I must the following things buy: paper, pencils and a ruler  
'I need to buy (the following things): paper, pencils and a ruler.'
- b. Kopen moet ik: papier, potloden en een liniaal.
- b'. \*Kopen: papier, potloden en een liniaal moet ik.

Haeseryn et al. notice further that in more formal contexts nominal arguments can occasionally appear postverbally. This order, which is characterized as “expressive”, is quite obsolete: it is specially used if the postverbal noun phrase constitutes newsworthy information: (26) could be used as “breaking news” in a newscast, but not in a biography as a neutral way of expressing where and when the singer André Hazes died. Cases like (26) are clearly part of the periphery of the language and can thus be ignored in a synchronic syntactic description of core grammar.

- (26) Te Woerden is op 53-jarige leeftijd overleden de zanger André Hazes.  
in Woerden is at 53-years age died the singer André Hazes  
'In Woerden the singer André Hazes has died at the age of 53.'

Finally we want to note that free relatives (that is, relative clauses without an overtly realized antecedent) can readily be found in postverbal position, just like relative clauses with an overt antecedent. If free relatives were noun phrases, this would be a counterexample to the claim that nominal arguments cannot be extraposed, but the examples in (27) show that the two cases can be unified if we assume that the antecedents of free relatives are syntactically present but lack phonetic content. We return to extraposition of relative clauses in Section 12.4.

- (27) a. dat Jan de mensen<sub>i</sub> prijst [die<sub>i</sub> hij bewondert]. [overt antecedent]  
that Jan the people praises who he admires  
'that Jan praises the people he admires'
- b. dat Jan Ø<sub>i</sub> prijst [wie<sub>i</sub> hij bewondert]. [phonetically empty antecedent]  
that Jan praises who he admires  
'that Jan praises who(ever) he admires.'

B. Clausal complements

Clausal complements occupy the postverbal position, as in (28a). It is normally not possible for complement clauses to precede the postverbal verb(s): example (28b) is only acceptable as a direct speech construction, that is, if Jan has literally pronounced the phrase “dat het hem spijt”; see Section 5.1.2.4, sub II, for a discussion of such cases.

- (28) a. Hij heeft gezegd [dat het hem spijt].  
           he has said that it him regrets  
           ‘He has said that he regrets it.’  
       b. #Hij heeft [dat het hem spijt] gezegd.

Factive clauses, like the bracketed phrase in (29), constitute another apparent exception to the general rule, but Section 5.1.2.3 has shown that it is plausible that the preverbal clause in (29b) is actually nominal in nature; we refer the reader to this section for detailed discussion.

- (29) a. Jan heeft nooit betreurd [dat hij taalkundige is geworden].  
           Jan has never regretted that he linguist is become  
           ‘Jan has never regretted that he has become a linguist.’  
       b. Jan heeft [dat hij taalkundige is geworden] nooit betreurd.

Example (30b) shows that the clausal complement in (28a) can be pied piped under VP-topicalization; we added some material to the construction in order to make the resulting structure more balanced. The fact that pied piping is possible strongly suggests that the complement clause is part of the verbal projection. This conclusion may be supported by the fact that stranding of the complement clause is definitely marked compared to pied piping.

- (30) a. Gezegd [dat het hem spijt] heeft hij nog niet.  
           said that it him regrets has he yet not  
       b. ??Gezegd heeft hij nog niet [dat het hem spijt].  
           said has he yet not that it him regrets

The (b)-examples in (31) show that the results are quite different when the clause is introduced by the anticipatory pronoun *het* ‘it’. The fact that the clause must be stranded in this case suggests that it occupies a position different from argument clauses that are not introduced by *het* ‘it’; it is not extraposed but right-dislocated.

- (31) a. Jan heeft *het* nog niet gezegd [dat het hem spijt].  
           Jan has it yet not said that it him regrets  
           ‘Jan hasn’t said it yet that he regrets it.’  
       b. \*Gezegd [dat het hem spijt] heeft Jan *het* nog niet.  
           said that it him regrets has Jan it yet not  
       b’. Gezegd heeft Jan *het* nog niet [dat het hem spijt].  
           said has Jan it yet not that it him regrets

This conclusion is also supported by the fact that argument clauses that are not introduced by *het* show a different behavior with respect to *wh*-extraction than the

corresponding clauses that are introduced by *het*; Section 11.3.1.1, sub III, has shown that *wh*-extraction is only allowed in the absence of this anticipatory pronoun only. If the anticipatory pronoun functions as the true direct object while its associate clause is simply an apposition, this follows from the claim that *wh*-extraction is possible from complement clauses only; see the discussion in Subsection A.

- (32) a. Jan heeft (het) gezegd [dat hij een mooi boek ging kopen].  
 Jan has it said that he a beautiful book went buy  
 ‘Jan has said (it) that he was going to buy a beautiful book.’  
 b. Welk boek<sub>i</sub> heeft Jan gezegd [dat hij <sub>t<sub>i</sub></sub> ging kopen]?  
 which book has Jan said that he went buy  
 ‘Which book has Jan said that he was going to buy?’  
 b’. \*Welk boek<sub>i</sub> heeft Jan het gezegd [dat hij <sub>t<sub>i</sub></sub> ging kopen]?  
 which book has Jan it said that he went buy

That the anticipatory pronoun functions as the true object is supported by the fact illustrated in (33) that its associate clause is optional: direct objects are normally obligatory, and it is clear that the pronoun must be present if the clause is omitted. Note in passing that the number sign indicates that the string without the pronoun is used in academic circles as a translation of Latin *dixi* ‘I have spoken’ with the meaning ‘I have said all I have to say’; this is clearly not part of Dutch °core grammar and can thus be ignored in our syntactic description.

- (33) Jan heeft \*(het) gezegd.  
 Jan has it said  
 ‘Jan has said it.’

This subsection has shown that argument clauses are obligatorily extraposed. This was illustrated for finite clauses only, but the same holds for opaque and semi-transparent infinitival argument clauses, while transparent infinitival argument clauses undergo a process of cluster formation. Since discussing this would simply repeat much of the discussion in Section 5.2, we will not digress on this here.

### C. PP-complements

Extraposed arguments can be easily distinguished from afterthoughts and backgrounded phrases: because arguments are normally obligatory, afterthoughts and backgrounded phrases require some anchor in the ‘‘true’’ argument position. This can be readily shown by means of the verb *houden* ‘to like’, which obligatorily selects a PP-complement introduced by *van*: examples (34b&c) shows that the presence of a pronominal PP such as *daarvan* ‘of that’ is only possible (and then in fact obligatory) if the postverbal PP is preceded by an intonation break.

- (34) a. dat Els erg \*(van lof) houdt.  
 that Els a.lot of chicory likes  
 ‘that Els likes chicory a lot.’  
 b. dat Els erg (\*daarvan) houdt van lof. [extraposition]  
 that Els a.lot of.that likes of chicory  
 ‘that Els likes chicory a lot.’

- c. dat Els erg \*(daarvan) houdt, van LOF/lof. [right dislocation]  
 that Els a.lot there.of likes of chicory  
 'that Els likes it a lot, chicory.'

Some verbs, like *wachten* 'to wait' in (35a), optionally take a PP-complement. In such cases, the pattern that arises is different. The (b)-examples in (35) first show that postverbal PPs must be preceded by an intonation break if a pronominal PP such as *daarop* 'for that' is present; in this respect, constructions with an optional PP-complement behave just like constructions with an obligatory PP-complement. Recognizing afterthoughts is not very difficult as the PP is preceded by an intonational break and assigned contrastive accent, but distinguishing extraposed and backgrounded PPs is harder, as this mainly rests on the intonation break, which need not be very prominent in actual speech. The main thing for our present purposes is, however, that the intonational break is optional in slow, careful speech; we can therefore conclude that extraposition and backgrounding right-dislocation are both available.

- (35) a. dat Jan (op de uitslag) wacht. [extraposition]  
 that Jan for the result waits  
 'that Jan is waiting for the result.'
- b. \*dat Jan daarop wacht op de uitslag. [extraposition]  
 that Jan for.that waits for the result
- b'. dat Jan daarop wacht, op de UITSLAG/uitslag. [right dislocation]  
 that Jan for.that waits for the result
- c. dat Jan wacht op de uitslag. [extraposition]  
 that Jan waits for the result
- c'. dat Jan wacht, op de UITSLAG/uitslag. [right dislocation]  
 that Jan waits for the result

There are at least two reasons for assuming that extraposed PPs are part of the clause. The first reason is phonological in nature and concerns the placement of (non-contrastive) sentence accent. Sentence accent can easily be located on the extraposed PP; it is in fact the neutral placement of this accent. In the case of right dislocation, on the other hand, sentence accent must precede the right-dislocated PP. This is shown in (36), in which sentence accent is given in italics.

- (36) a. dat Jan wacht op de *uitslag*. [extraposition]  
 that Jan waits for the result
- b. dat Jan *wacht*, op de UITSLAG/uitslag. [right dislocation]  
 that Jan waits for the result

The fact that sentence accent can occur on extraposed PPs conclusively shows that extraposed PPs are located clause-internally. A second reason for assuming this is that they can be pied piped under VP-topicalization, as is shown in (37a), although it should be noted that some speakers prefer the order in (37a'), in which the PP-complement is preverbal; this might be due to the fact that there is no information-structural reason for extraposition given that the clause-initial VP as a whole functions as a topic/focus. Example (37b) shows that stranding of the complement-PP gives rise to a degraded result.



- (37) a. <sup>(?)</sup>Houden van lof zal ik nooit.  
 like of chicory will I never  
 a'. Van lof houden zal ik nooit.  
 of chicory like will I never  
 b. <sup>??</sup>Houden zal ik nooit van lof.  
 like will I never of chicory

Because the contrast between the two primeless examples in (37) is not as sharp as one would like, we illustrate the same again in (38) by means of the verb *rekenen*, which requires a PP-complement headed by *op* 'on' if used as the PO-verb meaning 'to count/bank (on)'.

- (38) a. <sup>(?)</sup>Rekenen op een bonus doet hij niet.  
 count on a bonus does he not  
 a'. Op een bonus rekenen doet hij niet.  
 on a bonus count does he not  
 b. <sup>\*?</sup>Rekenen doet hij niet op een bonus.  
 count does he not on a bonus

Backgrounded PPs cannot easily be pied piped by VP-topicalization, as is clear from the fact illustrated by the (a)-examples in (39) that for at least some speakers they can only occur postverbally. Example (39b') shows that afterthoughts are marginally possible after topicalized VPs with an anticipatory pronominal PP, but only if preceded and followed by very distinct intonation breaks. Example (39b) shows that afterthoughts may also occur in postverbal position. We illustrate the same again in (40) by means of the verb *rekenen* (*op*) 'to count/bank (on)'

- (39) a. Daarvan houden zal ik nooit, van lof.  
 of.that like will I never of chicory  
 a'. <sup>\*?</sup>Daarvan houden, van lof, zal ik nooit.  
 of.that like of chicory will I never  
 b. Daarvan houden zal ik nooit, van LOF.  
 of.that like will I never of chicory  
 b'. Daarvan houden —van LOF— zal ik nooit.  
 of.that like of chicory will I never
- (40) a. Daarop rekenen doet hij niet, op een bonus.  
 on.that count does he not on a bonus  
 a'. <sup>??</sup>Daarop rekenen, op een bonus, doet hij niet.  
 on.that count on a bonus does he not  
 b. Daarop rekenen doet hij niet, op een BONUS.  
 on.that count does he not on a bonus  
 b'. Daarop rekenen —op een BONUS— doet hij niet.  
 on.that count on a bonus does he not

The discussion above suggests that extraposed and right-dislocated PPs occupy different positions. Since extraposed PPs are like extraposed clauses in that they are obligatorily pied piped under VP-topicalization, the simplest theory would be that these occupy the same structural position in the clause. If true, we would expect that

extraposed PPs also behave like extraposed clauses in that they allow *wh*-extraction. This expectation is not borne out, however, as extraposed PP-complements are islands for *wh*-extraction; example (41b) shows that *wh*-extraction is possible only if the stranded preposition immediately precedes the clause-final verb(s).

- (41) a. Jan heeft <op de brief> gewacht <op de brief>.  
 Jan has for the letter waited  
 ‘Jan has waited for the letter.’  
 b. Waar<sub>i</sub> heeft Jan <[op t<sub>i</sub>] > gewacht <\*[op t<sub>i</sub>] >?  
 where has Jan for waited  
 ‘What has Jan waited for?’

*D. Conclusion*

The previous subsections have shown that nominal, clausal and prepositional arguments exhibit different extraposition behavior in the way indicated in Table 1.

Table 1: *Extraposition of arguments*

TYPE OF ARGUMENT	EXTRAPOSITION OPTION	ISLANDHOOD OF EXTRAPOSED PHRASE
nominal	impossible	n.a.
clausal	obligatory	extraction possible
prepositional	optional	extraction impossible

In early generative grammar, it is generally assumed that Dutch has an underlying OV-structure: objects are uniformly base-generated to the left of the verb(s) in clause-final position. This implies that constructions with extraposed objects are derived by rightward movement. De Haan (1979) pointed out the movement analysis of extraposed object clauses is problematic in view of the fact that these allow *wh*-extraction in bridge verb contexts; this is inconsistent with the movement analysis because movement creates syntactic islands (the so-called °freezing effect). De Haan concluded from this that argument clauses are base-generated to the right of the clause-final verbs.

If nominal and clausal direct objects do have the same underlying base position, there is only one option left: they are base-generated in the surface position of the clause and the nominal phrase undergoes an obligatory movement to the left into a position to the left of the clause-final verbs. Although it raises the question why extraction from nominal arguments is possible (as is clear from, e.g., the so-called *wat voor* split), this position seems to be currently taken by many (but not all) generative linguists; cf. Zwart (1997/2011:ch.9) and Broekhuis (2008:ch.2).

The fact that extraposed PP-complements only allow for *wh*-extraction in preverbal position strongly suggests that they differ in a non-trivial way from extraposed argument clauses. More specifically, they differ from extraposed clauses in that they cannot be base-generated in postverbal position. In principle there are two ways of accounting for extraposed complement PPs: either the PP is moved rightward across the verb into the postverbal position, as was standardly assumed in early generative grammar, or some verbal projection is moved leftward into a position to the left of the PP; we refer the reader to Barbiers (1995) for a discussion of the latter option.

What is especially relevant for our present discussion is that we can conclude from the discussion above that extraposition cannot be considered a uniform phenomenon that can be accounted for by means of a single (movement) rule. The ramifications of the pattern given in Table 1 are currently still under investigation; a review of a number of theoretical options is given in Section 9.4, sub I, to which we refer the reader for more discussion as well as suggestions for further reading.

## II. Complementives

This subsection will be short as the main issues were already discussed in Section 2.2.1, sub III and IV, to which we refer the reader for a more detailed discussion. The examples in (42) show that complementives occupy a position to the left of the verb(s) in clause-final position, regardless of the type of construction.

- (42) a. dat Jan <erg nerveus> is <\*erg nerveus>. [copular construction]  
 that Jan very nervous is  
 ‘that Jan is very nervous.’
- b. dat Els Jan <erg nerveus> vindt <\*erg nerveus>. [vinden-construction]  
 that Els Jan very nervous considers  
 ‘that Els considers Jan very nervous.’
- c. dat Els Jan <erg nerveus> maakt <\*erg nerveus>. [resultative construction]  
 that Els Jan very nervous makes  
 ‘that Els makes Jan very nervous.’

The placement of the complementive is not affected by its categorial status either: the copular examples in (43) show that nominal, adjectival and adpositional complementives must all precede the verbs in clause-final position.

- (43) a. dat Jan <een vervelende knul> is <\*een vervelende knul>. [NP]  
 that Jan an annoying guy is  
 ‘that Jan is an annoying guy.’
- b. dat Jan <erg vervelend> is <\*erg vervelend >. [AP]  
 that Jan very annoying is  
 ‘that Jan is very annoying.’
- c. dat Jan <in zijn werkkamer> is <\*in zijn werkkamer>. [PP]  
 that Jan in his study is  
 ‘that Jan is in his study.’

The examples in (44) show the same for the *vinden*-construction; note that locational PPs cannot be used in the *vinden*-construction due to the fact that the complementive must be subjective in nature. For this reason we have used an idiomatic PP with adjectival meaning in the sense that it denotes a property.

- (44) a. dat Els Jan <een vervelende knul> vindt <\*een vervelende knul>. [NP]  
 that Els Jan an annoying guy considers  
 ‘that Els considers Jan an annoying guy.’
- b. dat Els Jan <erg vervelend> vindt <\*erg aardig>. [AP]  
 that Els Jan very annoying considers  
 ‘that Els considers Jan very annoying.’

- c. dat Els Jan <erg in de contramine> vindt <\*erg in de contramine>. [PP]  
 that Els Jan very in the CONTRAMINE considers  
 'that Els considers Jan very uncooperative.'

The examples in (45a&b) show the same for resultative constructions with an adjectival and a prepositional complementive; we added an instance with the verbal particle *neer*, which can likewise be considered a complementive; see Section 2.2.1, sub II. Resultative constructions do not take nominal complementives.

- (45) a. dat Jan het hek <blauw> verfde <\*blauw>. [AP]  
 that Jan the gate blue painted  
 'that Jan painted the gate blue.'
- b. dat Jan het boek <op de tafel> legde <\*op de tafel>. [PP]  
 that Jan the book on the table put  
 'that Jan put the book on the table.'
- c. dat Jan het boek <neer> legde <\*neer>. [particle]  
 that Jan the book down put  
 'that Jan put the book down.'

In light of the examples in (45b&c), example (46a) constitutes a potential problem for the claim that complements cannot follow the verb(s) in clause-final position, as the PP *op de tafel* can easily be extraposed. It seems plausible, however, that this PP in fact does not function as complementive, given that clauses cannot contain more than one complementive; the fact illustrated in (46b) that the particle *neer* cannot be extraposed suggests that this is the true complementive and that the PP performs some other function. We refer the reader to Section 2.2.1, sub IV, for a more detailed discussion and for further suggestions.

- (46) a. dat Jan het boek <op de tafel> naar legde <op de tafel>.  
 that Jan the book on the table down put  
 'that Jan put the book down on the table.'
- b. dat Jan het boek op de tafel <neer> legde <\*neer>.  
 that Jan the book on the table down put  
 'that Jan put the book down on the table.'

The examples in (47) show that we can find a similar phenomenon in resultative constructions headed by verbs prefixed with *be-*. Example (47a) shows that complementive *tot*-phrases typically precede the verb in clause-final position. However, if the *tot*-phrase is selected by a verb prefixed with *be-*, it can either precede or follow the verb.

- (47) a. dat de koning Jan <tot ridder> heeft geslagen <\*tot ridder>.  
 that the king Jan to knight has hit  
 'that the king made Jan a knight.'
- b. dat de koning Jan <tot adviseur> heeft benoemd <tot adviseur>.  
 that the king Jan to advisor has appointed  
 'that the king has appointed Jan as counselor.'

The contrast with respect to the placement of the *tot*-PP between the two examples in (47) would follow under the hypothesis discussed in Section 3.3.2, sub IIB, that the prefixes *be-*, *ver-* and *ont-* syntactically function as incorporated complementives;

on the hypothesis that clauses cannot contain more than one complementive, we must conclude that the *tot*-PP in (47b) performs some function other than complementive, as is also clear from the fact that it can be omitted: *dat de koning Jan heeft benoemd* ‘that the king has appointed Jan’.

This section has shown that complementives cannot be extraposed whatever their categorial status: NPs, APs and PPs behave alike in this respect. Given that postpositional and circumpositional phrases always function as complementives if used as clausal constituents, we expect that they do not occur in extraposed position. This expectation seems indeed borne out; postpositional and circumpositional phrases only occur in extraposed position if they function as postnominal modifiers (see Section 12.4 for examples).

- (48) a. dat Jan <het dak op> klom <\*het dak op>.  
 that Jan the roof onto climbed  
 ‘that Jan climbed onto the roof.’  
 b. dat Jan <over het hek heen> sprong <\*over het hek heen>.  
 that Jan over the fence HEEN jumped  
 ‘that Jan jumped over the fence.’

What may be more surprising is that the circumpositional phrases cannot be split by extraposition but that this is possible under *wh*-movement. An illustration of this contrast is given in (49) for the circumpositional phrase *achter de optocht aan*. We refer the reader to Section P1.2.5 for detailed discussion.

- (49) a. dat de kinderen achter de optocht aan renden.  
 that the children after the parade AAN ran  
 ‘that the children ran after the parade.’  
 b. Achter welke optocht renden de kinderen aan?  
 after which parade ran the children AAN  
 ‘After which parade did the children run?’  
 c. \*dat de kinderen aan renden achter de optocht.  
 that the children AAN ran after the parade

### III. Other cases

Measure phrases selected by verbs like *duren* ‘to last’, *wegen* ‘to weigh’ and *kosten* ‘to cost’ probably do not function as complementives but nevertheless seem selected by the verb, as omitting the measure phrase would lead to a degraded result (unless the verb is contrastively stressed). The examples in (50) show that these phrases cannot be extraposed, whatever their categorial status.

- (50) a. dat de workshop <erg lang> duurt <\*erg lang>.  
 that the workshop very long lasts  
 ‘that the workshop takes a very long time.’  
 b. dat de workshop <een hele week> duurt <\*een hele week>.  
 that the workshop a whole week lasts  
 ‘that the workshop takes a whole week.’  
 c. dat de workshop <tot tien uur> duurt <??tot tien uur>  
 that the workshop until ten hour lasts  
 ‘The workshop continues until 10 o’clock.’

The examples in (51) show that the same holds for APs and PPs that accompany verbs like *wonen* 'to live' and *verblijven* 'to lodge/live'.

- (51) a. dat Jan <in Utrecht> woont <\*in Utrecht>.  
 that Jan in Utrecht lives  
 'that Jan lives in Utrecht.'  
 b. dat Jan <erg comfortabel> woont <\*erg comfortabel>.  
 that Jan very comfortably lives  
 'that Jan lives quite comfortably.'

#### IV. Conclusion

The previous subsections have discussed the extraposition options of clausal constituents selected by the verb (arguments, complementive and measure phrases). The discussion has shown that extraposition of arguments depends on their categorial status: extraposition is impossible with nominal arguments, obligatory with clausal arguments and optional with prepositional arguments. Extraposition of complementives is impossible, irrespective of their category. The same holds for measure phrases selected by verbs such as *duren* 'to last'. One thing that we did not discuss but should be mentioned is that extraposition of clausal arguments does not seem to affect the proposition expressed by the clause (although we have seen that extraposition of PP-complements may have an effect on the information structure of the clause). This will become relevant in our discussion of postverbal clausal constituents that function as modifiers in Section 12.3.

### 12.3. Modifiers of the clause

This section discusses the extraposition options of clausal constituents that are not selected by the verb, such as adverbial phrases and °supplementives. Generally speaking, extraposition is restricted to prepositional and clausal adjuncts, that is, extraposition of nominal and adjectival adjuncts is impossible.

#### I. Prepositional adverbial phrases

It is often taken for granted that locational and temporal adverbial PPs can be extraposed. That this is justified seems clear from the fact illustrated in (52) that such PPs normally do not have to be preceded by an intonation break if they occur in postverbal position.

- (52) a. dat Jan graag in de tuin eet. [locational]  
 that Jan gladly in the garden eats  
 'that Jan likes to eat in the garden.'  
 a'. dat Jan graag eet in de tuin.  
 b. dat Jan na het eten graag een sigaret rookt. [temporal]  
 that Jan after the meal gladly a cigarette smokes  
 'that Jan likes to smoke a cigarette after dinner.'  
 b'. dat Jan graag een sigaret rookt na het eten.

That we are dealing with extraposition in the primed examples in (52) is further supported by the fact that the adverbial PPs can easily be pied piped under VP-topicalization.

- (53) a. Eten in de tuin doet Jan graag.  
eat in the garden does Jan gladly  
b. Een sigaret roken na het eten doet Jan graag.  
a cigarette smoke after the meal does Jan gladly

Another argument for assuming extraposition may be that accent can be placed on extraposed adverbial PPs. It should be noted, however, that speakers sometimes seem to entertain different ideas on the question as to whether this results in a neutral intonation pattern: while Van den Berg (1978:222) claims the accent on the PP to be the (non-contrastive) sentence accent, as indicated in (54b), Mark de Vries (p.c.) claims it to be a contrastive accent, as indicated in (54b'). We will leave this issue open for future research.

- (54) a. dat Jan graag in de *tuin* eet.  
that Jan gladly in the garden eats  
'that Jan likes to eat in the garden.'  
b. %dat Jan graag eet in de *tuin*.  
b'. dat Jan graag *eet* in de *TUIN*

Section 12.2, sub IV, observed that extraposition does not affect the propositional meaning of the construction. In order to establish whether we are dealing with extraposition or right dislocation, it may therefore be useful to investigate the propositional meaning of the constructions under consideration. But first let us look again at the (a)-examples in (52) in order to show that the structural position of the adverbial phrase in the clause may affect its extraposition options. Under a neutral (non-contrastive) intonation pattern, example (52a) expresses that Jan likes a certain thing, namely, eating in the garden: LIKE TO DO (Jan, eating in the garden). The extraposition example (52a') expresses exactly the same propositional content, and the same holds for the VP-topicalization construction in (53a). Things look different in the case of the (b)-examples in (52). Example (52b), repeated as (55a), expresses that Jan likes to do a certain thing after dinner, namely smoking a cigarette: LIKE TO DO AFTER DINNER (Jan, smoking a cigarette). However, this is not what is expressed by example (52b') or the VP-topicalization construction in (53b), which expresses that Jan likes to do a certain thing, which is smoking a cigarette after dinner: LIKE TO DO (Jan, smoking a cigarette after dinner). This strongly suggests that (52b') cannot be considered the extraposition counterpart of (55a), but should be considered the counterpart of (55b), which does express the same meaning. If we assume that the subject-oriented adverb *graag* 'gladly' has a fixed position in the structure, this suggests that the structural position of the adverbial PP may determine whether extraposition is possible or not.

- (55) a. dat Jan na het eten graag een sigaret rookt.  
that Jan after the meal gladly a cigarette smokes  
a'. LIKE TO DO AFTER DINNER (Jan, smoking a cigarette)  
b. dat Jan graag na het eten een sigaret rookt.  
that Jan gladly after the meal a cigarette smokes  
b'. LIKE TO DO (Jan, smoking a cigarette after dinner)



This phenomenon is more general: Chapter 8 argues that clausal adverbs such as *waarschijnlijk* ‘probably’ or *vaak* ‘often’ are located at the boundary of the lexical and the functional domain of the verbal projection (see Section 9.1 for an introduction to these notions): elements appearing to the left of such adverbs are located in the functional domain of the verb while elements appearing to the right of such adverbs are part of the lexical domain of the verb. Now consider the primeless examples in (56) and their paraphrases in the primed examples.

- (56) a. dat Jan vaak na het eten in slaap valt.  
 that Jan often after the meal in sleep falls  
 ‘that Jan often falls asleep after dinner.’
- a'. Het is vaak zo dat Jan na het eten in slaap valt.  
 it is often the.case that Jan after the meal in sleep falls  
 ‘It is often the case that Jan falls asleep after dinner.’
- b. dat Jan na het eten vaak in slaap valt.  
 that Jan after the meal often in sleep falls  
 ‘that Jan often falls asleep after dinner.’
- b'. Het is na het eten vaak zo dat Jan in slaap valt.  
 it is after the meal often the.case that Jan in sleep falls  
 ‘It is often the case after dinner that Jan falls asleep.’

The extraposition and VP-topicalization constructions in the (a)-examples in (57) correspond in their propositional meaning to example (56a), while the right-dislocation and topicalization constructions in the (b)-examples correspond in their propositional meaning to example (56b). Note that the meaning contrast between the two primeless examples in (57) may not be very sharp, but this is certainly the case for the meaning contrast between the two primed examples. If our intuitions are correct, this strongly suggests that adverbial PPs can be extraposed only if they are in a hierarchically lower position than the clausal adverbs, that is, when they occupy a position in the lexical domain of the verb.

- (57) a. dat Jan vaak in slaap valt na het eten.  
 that Jan often in sleep falls after the meal
- a'. In slaap vallen na het eten doet Jan vaak.  
 in sleep fall after the meal does Jan often
- b. dat Jan vaak in slaap valt, na het eten.  
 that Jan often in sleep falls after the meal
- b'. In slaap vallen doet Jan vaak, na het eten.  
 in sleep fall does Jan often after the meal

The hypothesis that adverbial PPs should be in the lexical domain of the main verb in order to be able to occur in extraposed position provides us with two strong predictions: if an adverbial PP can occur to the right of a clausal adverb, it can also be in extraposed position; if an adverbial PP can only occur to the left of a clausal adverb, it cannot be in extraposed position. This seems more or less the correct generalization. The examples in (58) show that the first prediction is correct for instrumental *met*-PPs, agentive *door*-phrases, and *wegens*-PPs expressing a cause/reason; these may follow the clausal adverb *vaak* ‘often’ and extraposition is

fully acceptable, as is clear from the fact illustrated in the primed examples that the postverbal PPs can be pied piped under VP-topicalization.

- (58) a. dat Jan vaak <met deze kwast> schildert <met deze kwast>.  
 that Jan often with this brush paints  
 'that Jan often paints with this brush.'  
 a'. Schilderen met deze kwast doet Jan vaak.  
 paint with this brush does Jan often  
 b. Jan wordt vaak <door Peter> geplaagd <door Peter>.  
 Jan is often by Peter teased  
 b'. Geplaagd door Peter wordt Jan vaak.  
 teased by Peter is Jan often  
 c. Dat Jan vaak <vanwege ziekte> lessen verzuimt <vanwege ziekte>.  
 that Jan often because.of illness lessons be-absent  
 'that Jan often misses lessons because of illness.'  
 c'. Lessen verzuimen vanwege ziekte doet Jan vaak.  
 lessons be.absent because.of illness does Jan often

That the second prediction is also on the right track is illustrated in (59) by means of an adverbial *ondanks*-PP expressing concession. Example (59a) first shows that this PP must precede the clausal adverb *vaak* 'often'. We therefore expect extraposition to be impossible, and this is indeed borne out: example (59b) shows that the PP must be preceded by an intonation break when it is in postverbal position (Veld 1993:144). That we are not dealing with extraposition is further supported by the (c)-examples, which show that the PP cannot be pied piped under VP-topicalization.

- (59) a. dat Jan <ondanks zijn ziekte> toch vaak <\*ondanks zijn ziekte> sport.  
 that Jan despite his illness PRT often does.sport  
 'that Jan often exercises despite his illness.'  
 b. dat Jan toch vaak sport <sup>?(,)</sup> ondanks zijn ziekte.  
 that Jan PRT often does.sport despite his illness  
 c. \*Sporten (,) ondanks zijn ziekte, doet Jan toch vaak.  
 do.sport despite his illness does Jan PRT often  
 c'. Sporten doet Jan toch vaak, ondanks zijn ziekte.  
 do.sport does Jan PRT often despite his illness

Since most adverbial PPs that can occur to the left of the clausal adverbs can also occur to their right, there are not so very many systematic cases that exhibit the same pattern as concessive adverbial PPs. Another, less frequent, case is the adverbial PP *in de regel* 'normally' in (60a). Example (60b) shows that this PP must be preceded by an intonation break if it is in postverbal position, and the (c)-examples show that it must be stranded by VP-topicalization.

- (60) a. dat Jan <in de regel> vaak <\*in de regel> sport.  
 that Jan as a rule often does.sport  
 'that normally Jan often exercises despite his illness.'  
 b. dat Jan vaak sport \*(,) in de regel.  
 that Jan often does.sport as a rule

- c. \*Sporten (,) in de regel, doet Jan vaak.  
do.sport as a rule does Jan often
- c'. Sporten doet Jan vaak, in de regel.  
do.sport does Jan often as a rule

The examples in (61), finally, show that the clausal adverbs themselves cannot be extraposed either if they have the form of a PP; see Veld (1993:144). Example (61b) shows that the adverbial PP *tot drie maal toe* 'up to three times' must be preceded by an intonation break when in postverbal position, and the (c)-examples show that it must be stranded by VP-topicalization.

- (61) a. dat we tot driemaal toe een explosie hoorden.  
that we TOT three.times TOE an explosion heard  
'that we heard an explosion thrice.'
- b. dat we een explosie hoorden \*(,) tot driemaal toe.  
that we an explosion heard TOT three.times TOE
- c. Een explosie horen (,) tot driemaal toe, deden we.  
an explosion hear TOT three.times TOE did we
- c'. Een explosie horen deden we, tot driemaal toe.  
an explosion hear did we TOT three.times TOE

This subsection has put forward the hypothesis that adverbial PPs can be extraposed only if they can occur to the right of the clausal adverbs, that is, if they are part of the lexical domain of the main verb. Adverbial PPs cannot be extraposed if they can only occur to the left of the clausal adverbs, that is, if they are part of the functional domain of the main verb. Sentential adverbial PPs, which seem to be located at the boundary between the two domains cannot be extraposed either.

## II. Adverbial clauses

Adverbial clauses seem to exhibit more or less the same behavior as their prepositional counterparts, although they may be expected to occur more frequently in extraposed position, as extraposition may be favored in the case of clauses by such factors as mentioned in Section 12.1, sub V. Their similarity in behavior is illustrated in (62) by means of a temporal clause with the same function as the temporal adverbial PP *na het eten* 'after dinner' in (55): example (62b) shows that the clause need not be preceded by an intonation break if it occurs postverbally, and (62c) shows that it can readily be pied piped under VP-topicalization. The primed examples show that the adverbial clause can also be right-dislocated.

- (62) a. dat Jan <graag> [nadat hij gegeten heeft] <graag> een sigaret rookt.  
that Jan gladly after he eaten has a cigarette smokes  
'that Jan likes to smoke a cigarette after he has eaten.'
- b. dat Jan graag een sigaret rookt [nadat hij gegeten heeft].  
that Jan gladly a cigarette smokes after he eaten has
- b'. dat Jan graag een sigaret rookt, [nadat hij gegeten heeft].  
that Jan gladly a cigarette smokes after he eaten has

- c. Een sigaret roken [nadat hij gegeten heeft] doet Jan graag.  
 a cigarette smoke after he eaten has does Jan gladly
- c'. Een sigaret roken doet Jan graag, [nadat hij gegeten heeft].  
 a cigarette smoke does Jan gladly after he eaten has

The examples in (63) indicate that the distribution of adverbial clauses introduced by *ondanks* is subject to the same restrictions as the adverbial PP *ondanks zijn ziekte* 'despite his illness' in (59). Example (63a) first shows that the adverbial clause must precede the sentential adverb *vaak* 'often', as placing it in the position indicated by <\*> gives rise to a severely degraded result. Example (63b) shows that the clause is preferably preceded by an intonation break if it occurs in postverbal position (although this preference seems less strong than in the case of a PP). The (c)-examples show that the clause cannot be pied piped under VP-topicalization but must be stranded. All of this all suggests that the clause cannot be extraposed.

- (63) a. dat Jan <ondanks dat hij ziek is> toch vaak <\*> sport.  
 that Jan despite that he ill is PRT often does.sport  
 'that Jan often exercises despite the fact that he is ill.'
- b. dat Jan toch vaak sport <sup>?</sup>(,) [ondanks dat hij ziek is].  
 that Jan PRT often does.sport despite that he ill is
- c. \*Sporten (,) ondanks dat hij ziek is, doet Jan toch vaak.  
 do.sport despite that he ill is does Jan PRT often
- c'. Sporten doet Jan toch vaak, [ondanks dat hij ziek is].  
 do.sport does Jan PRT often despite that he ill is

Infinitival temporal adverbial clauses are like their finite counterparts in that they may occur in pre- and postverbal position. The postverbal clause can be in extraposed position: it need not be preceded by an intonation break and it can easily be pied piped under VP-topicalization. The infinitival clause can also be right-dislocated but we will not illustrate this here.

- (64) a. dat Jan <graag> [alvorens te eten] een glas jenever drinkt.  
 that Jan gladly before to eat a glass [of] Dutch.gin drinks  
 'that Jan likes to drink a glass of Dutch gin before eating.'
- b. dat Jan graag een glas jenever drinkt [alvorens te eten].  
 that Jan gladly a glass [of] Dutch.gin drinks before to eat
- c. Een glas jenever drinken [alvorens te eten] doet Jan graag.  
 a glass [of] Dutch.gin drink before to eat does Jan gladly

Some adverbial clauses do not seem to be comfortable in preverbal position. This holds, for instance, for the adverbial clauses found in conditional and consecutive constructions. The answer to the question as to whether they are in extraposed or right-dislocated position therefore has to rely entirely on VP-topicalization. We illustrate this in (65) for conditional constructions. Example (65a) shows that the *when*-clause cannot readily occur in the middle field; it can only occur in this position as a parenthetical, in which case it should be preceded and followed by an intonation break. That the postverbal *when*-clause cannot easily be pied piped under VP-topicalization, as illustrated in (65b), suggests that it is right-dislocated.

- (65) a. dat Jan <<sup>??</sup>als hij gedronken heeft> slecht slaapt <als hij gedronken heeft>.  
 that Jan if he drunk has badly sleeps  
 'that Jan sleeps badly when he has drunk alcohol.'
- b. Slapen <<sup>??</sup>als hij gedronken heeft> doet Jan slecht <als hij gedronken heeft>.  
 sleep if he drunk has does Jan badly

The examples in (66) illustrate the same for consecutive constructions. Example (66a) shows that the adverbial clause expressing the consequence must be placed in postverbal position: placement of this clause in the middle field positions indicated by <\*> is entirely impossible, even as a parenthetical clause. The adverbial clause in (66a) is again preferably preceded by an intonation break, which suggests that it is right-dislocated. This is supported by the fact illustrated in (b)-examples in (66) that the adverbial clause must be stranded under VP-topicalization.

- (66) a. dat Jan <\*> liever <\*> doorwerkt <zodat we alleen moeten gaan>.  
 that Jan rather on-works so.that we alone must go  
 'Jan prefers to continue working, so that we have to go alone.'
- b. \*Doorwerken zodat we alleen moeten gaan doet Jan liever.  
 on-work so.that we alone must go does Jan rather
- b'. Doorwerken doet Jan liever, zodat we alleen moeten gaan.  
 on-work does Jan rather so.that we alone must go

As far as we know, the syntactic behavior of the various semantic types of postverbal adverbial clauses has not been studied systematically. The full story therefore has to await future research; the discussions found in Veld (1993:section 5.2.8) and De Vries (2002:ch.7) provide good starting points for a more in-depth investigation.

### III. Adjectival phrases

Adjectival adjuncts are excluded in extraposed position. The following subsections will discuss this for adverbial phrases and complementives.

#### A. Adverbial phrases

Adjectival adverbial phrases are excluded in extraposed position. This is illustrated in (67) for the adverbial phrase of manner *erg zorgvuldig* 'very carefully'. While (67a) shows that this phrase can precede the verb, it cannot easily follow it: the only way to improve (67b) is by assigning contrastive stress to the adverbial phrase or by adding an apposition marker such as *en wel*, which are typical properties of afterthoughts: *dat Jan het artikel las—(en wel) ERG zorgvuldig*. Example (67c) shows that VP-topicalization is also difficult in the case of a postverbal manner adverbial, although the stranding option again improves if contrastive stress or the apposition marker *en wel* is added to the adverbial phrase; *Het artikel lezen deed Jan—(en wel) ERG zorgvuldig*.

- (67) a. dat Jan het artikel erg zorgvuldig las.  
 that Jan the article very carefully read  
 ‘that Jan read the article read very carefully.’  
 b. dat Jan het artikel las \*(?) erg zorgvuldig.  
 that Jan the article read very carefully  
 c. Het artikel lezen <\*erg zorgvuldig> deed Jan, <?erg zorgvuldig>.  
 the article read very carefully did Jan

Adjectival adjuncts with other semantic functions are also incompatible with extraposition. Example (68) illustrates this for the adverbial *regelmatig* ‘regularly’, which can be used either as a VP or as a clausal adverb. Example (68b) shows that such adverbial phrases can only occur in postverbal position if they are preceded by an intonation break; the result of postverbal placement is best if the adjective *regelmatig* is assigned contrastive accent. Example (68c) shows that pied piping of the adverbial phrase under VP-topicalization is excluded; stranding is possible and again seems best if the adjective is assigned contrastive stress or preceded by the apposition marker *en wel*.

- (68) a. dat we regelmatig een explosie hoorden.  
 that we regularly an explosion heard  
 ‘that we regularly heard an explosion.’  
 b. dat we een explosie hoorden \*(,) regelmatig.  
 that we an explosion heard regularly  
 c. \*Een explosie horen (,) regelmatig, deden we.  
 an explosion hear regularly did we  
 c’. Een explosie horen deden we, (en wel) regelmatig.  
 an explosion hear did we and PRT regularly

Note in passing that the intonation break in the (c)-examples can be omitted and that the adverbial phrase is not necessarily assigned contrastive accent in the resulting utterance: *Een explosie horen deden we regelmatig*. Such cases probably involve stranding of a preverbal adverbial phrase. Unfortunately, the actual position of the supplementive cannot be inspected from the surface form of the clause because VP-topicalization has removed all material following it.

### B. Adjectival supplementives

Adjectival °supplementives are also incompatible with extraposition. The (b)-examples in (69) show that complementives can occur in postverbal position only if they function as afterthoughts: they must be preceded by an intonation break and assigned contrastive stress. The (c)-examples show that VP-topicalization cannot pied pipe postverbal supplementives; the supplementive must be stranded. It should be noted that, as in (68c), the intonation break in (69c) can be omitted and that the supplementive is normally not assigned contrastive accent in the resulting utterance: *Naar huis wandelen deed Jan tevreden*. Such cases probably involve stranding of the preverbal supplementive in (69a) but, unfortunately, the actual position of the supplementive cannot be inspected from the surface form of the clause because VP-topicalization has removed all material following it.

- (69) a. dat Jan tevreden naar huis wandelde.  
 that Jan satisfied to home walked  
 'that Jan walked home satisfied.'
- b. \*dat Jan naar huis wandelde (,) tevreden.  
 that Jan to home walked satisfied
- b'. dat Jan naar huis wandelde, TEVREDEN.  
 that Jan to home walked satisfied
- c. \*Naar huis wandelen <tevreden> deed Jan, <tevreden>.  
 to home walk satisfied did Jan
- c'. Naar huis wandelen deed Jan, TEVREDEN.  
 to home walk did Jan satisfied

It should further be pointed out that Veld (1993:133-4) claims that monosyllabic complementives cannot readily be used as afterthoughts for prosodic reasons: the dollar sign in (70) indicates that there is indeed a slight contrast with cases in polysyllabic or phrasal supplementives, such as *tevreden* in (69) or *moe en tevreden* in (70), but we still consider examples of this sort acceptable.

- (70) %dat Jan ging naar huis, [MOE \$(maar TEVREDEN)].  
 that Jan went to home tired but satisfied  
 'that Jan went home, tired (but satisfied).'

### C. Conclusion

This section has shown that adjectival adjuncts (adverbial phrases and complementives) cannot occur in extraposed position; when they occur postverbally they are right-dislocated. We refer to Veld (1993) and De Vries (2002:291), for more examples, while noting that the latter is quite (and in our view sometimes too) lenient in his acceptability judgments.

### IV. Noun phrases

Nominal adverbial phrases have a temporal meaning. A prototypical example is given in (71a). Example (71) shows that the phrase *de hele dag* 'the whole day' can be used in postverbal position but is then preferably preceded by an intonation break; cf. Veld (1993:127). The fact that omitting the intonation break seems marginally possible in slow careful speech may give rise to the idea that extraposition is at least a marginal option. However, the fact illustrated in (71c) that pied piping the postverbal phrase gives rise to a highly marked result suggests that we are dealing with a right-dislocated phrase after all; the example improves if the adverbial phrase is preceded and followed by an intonation break, but in that case we are dealing with a parenthetical.

- (71) a. dat Jan graag de hele dag leest.  
 that Jan gladly the whole day reads  
 'that Jan likes reading all day long.'
- b. dat Jan graag leest <sup>?</sup>(,) de hele dag.  
 that Jan gladly reads the whole day
- c. Lezen <<sup>?</sup>de hele dag> doet Jan graag, <de hele dag>.  
 read the whole day does Jan gladly



The examples in (71) involve cases in which the adverbial phrase refers to a time interval including speech time. The examples in (72) illustrate the same thing for a temporal adverbial phrase referring to a point in time following speech time.

- (72) a. dat Els volgende week graag een lezing geeft.  
 that Els next week gladly a talk gives  
 ‘that Els will be glad to give a talk next week.’
- b. dat Els graag een lezing geeft <sup>?</sup>(,) volgende week.  
 that Els gladly a talk gives next week
- b’. Een lezing geven <<sup>??</sup>volgende week> doet Els graag, <<sup>?</sup>volgende week>.  
 a talk give next week does Els gladly

Note that lexical items like *morgen* ‘tomorrow’ and *gisteren* ‘yesterday’, which are listed as adverbs in dictionaries exhibit the same behavior as the nominal phrases in (71) and (72), for which reason we simply treat them as nouns.

Recall from Section 12.2, sub III, that noun phrases can also be used as measure phrases indicating duration if selected by verbs such as *duren* ‘to last’. Although such measure phrases are often considered adverbial phrases, they differ from the cases discussed in this subsection in that they categorically reject postverbal placement: *dat de workshop <een hele dag> zal duren <\*een hele dag>* ‘that the workshop will take a full day’. The pied piping/stranding behavior of these measure phrases cannot be investigated, as constructions of this sort do not easily allow VP-topicalization: *\*Een hele dag duren doet/zal deze workshop*.

#### 12.4. Parts of constituents

There is a wide range of constructions in which a *part* of a clausal constituent occurs in postverbal position. Prototypical cases of such extraposed phrases are relative clauses and postnominal clauses/PPs (both modifiers and complements). Examples are provided in (73), in which the italicized parts clearly form a clausal constituent semantically. We refer to cases like these as SPLIT EXTRAPOSITION constructions (by analogy to the notion of SPLIT TOPICALIZATION, which refers to cases in which a part of a clausal constituent is topicalized). Italics will be used throughout this subsection to indicate the split clausal constituents.

- (73) a. Hij heeft *de man* bezocht *die hier gisteren* was. [relative clause]  
 he has the man visited who here yesterday was  
 ‘He has visited the man who was here yesterday.’
- b. dat Jan *de vraag* stelde *of het regende*. [complement clause]  
 that Jan the question put whether it rained  
 ‘that Jan asked the question whether it rained.’
- c. dat Jan *een boek* gekocht heeft *uit de 16<sup>e</sup> eeuw*. [PP-modifier]  
 that Jan a book bought has from the 16<sup>th</sup> century  
 ‘that Jan has bought a book from the 16<sup>th</sup> century.’

For a long time, generative grammar has taken it for granted that split extraposition constructions are derived by movement from underlying structures in which the italicized parts are syntactic units; cf. Baltin (2006) for a review. Subsection I will show that there are reasons for rejecting such a movement approach. Subsection II

continues by showing that split extraposition is not limited to relative clauses and complements/modifiers of noun phrases, but that it is a more general phenomenon. We illustrate this in (74) by cases in which an adjectival complementive is split: in (74a) the PP-complement *op Peter* of the adjective *boos* ‘angry’ is extraposed, and in (74b), the extraposed clause is part of a complex modifier phrase of the adjective *klein* ‘small’.

- (74) a. dat Marie *erg boos* is *op Peter*.  
 that Marie very angry is at Peter  
 ‘that Marie is very angry with Peter.’  
 b. dat de computer *zo klein* is *dat hij overal past*.  
 that the computer so small is that he everywhere fits  
 ‘that the computer is so small that it fits everywhere.’

The conclusion that split extraposition cannot be derived by movement may give rise to the idea that we are not dealing with extraposition but with some form of right dislocation; cf. Section 12.1, sub IV, where it is shown that extraposition and right dislocation are sometimes difficult to distinguish. Subsection III will argue against this hypothesis by showing that the postverbal parts of split extraposition constructions differ from right-dislocated phrases in that the former cannot be stranded under VP-topicalization; Kaan (1992) has in fact shown that both parts of the split constituent must be pied piped in order to obtain an acceptable result. We illustrate this in the (a)-examples in (75) for the extraposed relative clause in (73a); example (75b) is added to show that the full noun phrase can be stranded under VP-topicalization but in this case the relative clause is simply not extraposed, as is clear from the fact that it precedes the sentential negation *niet* ‘not’, which cannot occur in postverbal position. Kaan’s generalization will be used as a test for distinguishing the postverbal part in split extraposition constructions from right-dislocated phrases.

- (75) a. [*De man bezocht die hier gisteren was*] heeft hij niet.  
 the man visited who here yesterday was has he not  
 a'. \**[De man bezocht] heeft hij niet die hier gisteren was*.  
 a''. \**[Bezocht die hier gisteren was] heeft hij de man niet*.  
 b. *Bezocht heeft hij [de man die hier gisteren was] niet*.

The (a)-examples clearly show that the postverbal part in split extraposition constructions is clearly clause-internal. Subsection IV concludes by discussing a fairly recent alternative for the movement approach initiated by Koster (2000), according to which split extraposition is a form of juxtaposition of the VP and some other phrase.

### 1. Relative clauses and postnominal complements/modifiers

Prototypical cases of split extraposition involve nominal arguments with a relative clause or a postnominal clause/PP. We illustrate this again in the examples in (76): the primeless examples indicate the structures of the noun phrases in the non-split pattern, while the primed examples illustrate the split extraposition pattern.

- (76) a. dat hij [de man [die dit boek geschreven heeft]] kent.  
 that he the man who this book written has knows  
 ‘that he knows the man who has written this book.’  
 a’. dat hij *de man* kent *die dit boek geschreven heeft*.  
 that he the man knows who this book written has  
 b. dat hij [de bewering [dat Marie gelogen had]] niet kon weerleggen.  
 that he the assertion that Marie lied had not could rebut  
 ‘that he couldn’t rebut the claim that Marie had lied.’  
 b’. dat hij *de bewering* niet kon weerleggen *dat Marie gelogen had*.  
 that he the assertion not could rebut that Marie lied had  
 c. dat hij [de man [met het aapje]] gezien heeft.  
 that he the man with the monkey seen has  
 ‘that he has seen the man with the monkey.’  
 c’. dat hij *de man* gezien heeft *met het aapje*.  
 that he the man seen has with the monkey

For completeness’ sake, we add the examples in (77) in order to show that split extraposition is not only possible with prepositional phrases but also with post- and circumpositional phrases; cf. Veld (1993:section 4.3).

- (77) a. dat ze een weg <de berg op> bouwden <de berg op>.  
 that they a road the mountain up built  
 ‘that they built a road up the mountain.’  
 b. dat ze een gang <onder de weg door> groeven <onder de weg door>.  
 that they a tunnel under the road DOOR dug  
 ‘that they dug a tunnel underneath the road.’

Until the mid 1990’s many generative grammarians assumed that the split patterns in (76) and (77) are derived by movement. One reason was that a movement analysis immediately accounts for the fact that the postverbal phrase obeys selection restrictions imposed by the presumed selecting head, as well as the fact that the pre- and postverbal PP are in complementary distribution: cf. Corver (1991).

- (78) dat Jan de hoop <op/\*voor hulp> verloor <op/\*voor hulp>.  
 that Jan the hope on/for help lost  
 ‘that Jan lost all hope of help.’

The nature of the movement is not entirely clear, however. One generally accepted derivation involved the postulation of an extraposition transformation (which in the case of PPs was sometimes referred to as PP-over-V), which optionally moves the postnominal clause/PP rightwards into some postverbal position, as illustrated by structure (79a). Another view, which originates from the 1970’s and became quite popular after the publication of Kayne (1994), is the so-called raising (or promotion) analysis. According to this analysis, the noun phrase is generated to the right of the verb and subsequently moved into some position to left of the verb, while optionally stranding its post-nominal part; this is indicated by structure (79b), in which NP\* stands for a somewhat larger nominal projection than the moved NP-projection.

- (79) a. [... [NP ... N  $t_i$ ] ... V [REL-clause<sub>i</sub>/clause/PP]<sub>i</sub>] [extraposition/PP-over-V]  
 b. [... [NP ... N]<sub>i</sub> ... V [NP\*  $t_i$  [REL-clause<sub>i</sub>/clause/PP]]] [raising/promotion]

Despite the popularity of the two proposals there are many theoretical and empirical problems with them; we will provide some of the most important issues below and refer the reader to Koster (1973/1995/2000), Kaan (1992), De Vries (2002:ch.7), Boef (2013:ch.3), and references cited there for more detailed discussions.

A quite problematic aspect of the extraposition analysis in (79a) is that it presupposes that relative clauses and postnominal PPs can be extracted from noun phrases, while there is actually no independent evidence to support that claim. For example, while virtually any clausal constituent can be moved into clause-initial position, topicalization of relative clauses and postnominal clauses/Ps is excluded, as is illustrated by the primed examples in (80). The number sign in (80c') indicates that this example is acceptable if the *met*-PP is interpreted as a comitative adverbial phrase; this reading is irrelevant here.

- (80) a. Hij kent [de man [die dit boek geschreven heeft]].  
 he knows the man who this book written has  
 'He knows the man who has written this book.'
- a'. \**Die dit boek geschreven heeft* kent hij *de man*.  
 who this book written has knows he the man
- b. Hij kon [de bewering [dat Marie gelogen had]] niet weerleggen.  
 he could the assertion that Marie lied had not rebut  
 'He couldn't rebut the claim that Marie had lied.'
- b'. \**Dat Marie gelogen had* kon hij *de bewering* niet weerleggen.  
 that Marie lied had could he the assertion not rebut
- c. Hij heeft [de man [met het aapje]] gezien.  
 he has the man with the monkey seen  
 'He has seen the man with the monkey.'
- c'. #*Met het aapje* heeft hij *de man* gezien.  
 with the monkey has he the man seen

The unacceptability of the primed examples follows from the hypothesis that noun phrases are islands for movement (cf. Section 11.3.1.1, sub VB), but this hypothesis would make the extraposition analysis in (79a) highly implausible anyway. Of course, there are also arguments in favor of the extraposition analysis but these do not seem very strong. For example, it has been argued that noun phrases such as *het debuut van Hella Haasse* do allow topicalization of their postnominal PP. However, topicalization of this sort is possible only if the PP is headed by *van* or *over*, and Section N2.2.1, sub VC, has shown that such topicalized PPs can be analyzed as restrictive adverbial phrases.

- (81) a. Hij heeft [het debuut van Hella Haasse] gelezen.  
 he has the debut of Hella Haasse read  
 'He has read Hella Haasse's debut novel.'
- b. Hij heeft het debuut gelezen van Hella Haasse. [extraposition]  
 he has the debut read of Hella Haasse
- b'. Van Hella Haasse heeft hij het debuut gelezen. [topicalization]  
 of Hella Haasse has he the debut read

A more convincing argument in favor of the analysis in (79a) might be that °scrambling of the object across a clausal adverb has a deteriorating effect on extraposition; this may follow from the so-called °freezing effect, according to which moved phrases are islands for extraction. It should be noted, however, that Guéron (1980) has argued on the basis of English that extraposition is possible only from noun phrases that are part of the focus (new information) of the clause, while scrambled nominal arguments are typically part of the presupposition.

- (82) a. Hij heeft waarschijnlijk die man <met het aapje> gezien <met het aapje>.  
 he has probably that man with the monkey seen  
 ‘He has probably seen that man with the monkey.’  
 b. Hij heeft die man <met het aapje> waarschijnlijk gezien <\*met het aapje>.  
 he has that man with the monkey probably seen

Another potential argument against the freezing approach and in favor of Guéron’s proposal is that De Vries (2002:244) claims that split extraposition *is* possible in the case of topicalized phrases. It is not so clear, however, whether examples such as (83) indeed involve extraposition or whether we are dealing with right dislocation; the percentage signs in these examples indicates that according to some speakers an intonation break is preferred, which would suggest that we are dealing with right dislocation. Unfortunately, the VP-topicalization test from Section 12.1, sub IV, cannot be used to help us out in this case because the clause-initial position is already filled by the topicalized noun phrase itself; we therefore have to leave this issue for future research.

- (83) a. Dat boek heb ik de man gegeven % (,) dat hij graag wilde hebben.  
 that book have I the man given which he gladly wanted have  
 ‘I have given that man the book which he liked to have.’  
 b. Twee boeken heeft Jan hem gegeven % (,) met mooie foto’s.  
 two books has Jan him given with beautiful pictures  
 ‘Jan has given the man two books with beautiful pictures.’

Guéron’s claim may also tally with the fact that extraposition from noun phrases with definite articles is difficult and perhaps even impossible in English; cf. Baltin (2006). It should be noted, however, that replacing the demonstrative *die* ‘that’ by the definite article *de* ‘the’ in Dutch examples such as (82a) does not have the same far-reaching effect on acceptability judgments as in English, as is clear from the full acceptability of the examples in (76); see also Koster (2000). Whatever accounts for this conspicuous difference between English and Dutch, the main conclusion for the moment is that it is not *a priori* clear that an appeal to the syntactic notion of freezing is needed to account for the acceptability contrast indicated in the two examples in (82). This conclusion seems supported by the acceptability judgments on the examples in (84), which show that split extraposition becomes more difficult in general if more material intervenes between the extraposed phrase and its intended associate, which is given in italics; cf. Corver (1991:134).

- (84) a. Els zei dat *het zoontje* had opgebeld van de buren.  
 Els said that the son<sub>dim.</sub> had prt.-called of the neighbors  
 ‘Els said that the son of the neighbors had called.’
- b. <sup>??</sup>Els zei dat *het zoontje* haar had opgebeld van de buren.  
 Els said that the son<sub>dim.</sub> her had prt.-called of the neighbors  
 Intended reading: ‘Els said that the son of the neighbors had called her.’
- c. \*Els zei dat *het zoontje* haar vriendin had opgebeld van de buren.  
 Els said that the son<sub>dim.</sub> her friend had prt.-called of the neighbors  
 Intended reading: ‘Els said that the son of the neighbors had called her friend.’

Let us now turn to the raising analysis in (79b). A potential problem for this analysis is related to the fact that extraposition is not only possible from direct objects but also from indirect objects and subjects. In (85), we provide examples with extraposed relative clauses: the relative clauses and their antecedents are again in italics.

- (85) a. Jan heeft *iemand* ontmoet *die hem wil helpen*. [direct object]  
 Jan has someone met who him wants help  
 ‘Jan has met someone who wants to help him.’
- b. Jan heeft *iemand* 10 euro gegeven *die hem wil helpen*. [indirect object]  
 Jan has someone 10 euro given who him wants help  
 ‘Jan has given 10 euros to someone who wants to help him.’
- c. Er heeft *iemand* opgebeld *die hem wil helpen*. [subject]  
 there has someone prt.-called who him wants help  
 ‘Someone who wants to help him has telephoned.’

The examples in (85) involve indefinite nominal arguments but the examples in (86) show that split extraposition is also possible with definite nominal arguments (although the result seems slightly marked in case of an indirect object), provided that the nominal arguments are part of the focus (new information) of the clause and thus follow clausal adverbs such as *waarschijnlijk* ‘probably’ (if present); placement of *de man* further to the left gives rise to a degraded result. Note in passing that the examples in (86) refute De Haan’s (1974:176-7) claim that split extraposition is excluded in the case of (definite) indirect objects and subjects.

- (86) a. Jan heeft waarschijnlijk *de man* ontmoet *die hem wil helpen*.  
 Jan has probably the man met who him wants help
- b. <sup>(?)</sup>Jan heeft waarschijnlijk *de man* 10 euro gegeven *die hem wil helpen*.  
 Jan has probably the man 10 euro given who him wants help
- c. Gisteren heeft waarschijnlijk *de man* opgebeld *die hem wil helpen*.  
 yesterday has probably the man prt.-called who him wants help

Split extraposition with PPs is illustrated in (87). The case with an indirect object in (87b) is again somewhat marked but the case with a subject in (87c) is impeccable. Note that the acceptability of the (b)- and (c)-examples in (86) and (87) refutes De Haan’s (1974:176-7) claim that split extraposition is excluded in the case of (definite) indirect objects and subjects; the marked status of split extraposition with the indirect object in the (b)-examples should probably be attributed to the intervention effect noted in (84).

- (87) a. Jan heeft hier *veel mensen* ontmoet *met financiële problemen*  
 Jan has here many people met with financial problems  
 ‘Jan has met a lot of people with financial problems here.’
- b. ?Marie heeft *veel mensen* raad gegeven *met financiële problemen*.  
 Marie has many people advice given with financial problems  
 ‘Marie has given advice to many people with financial problems.’
- c. Hier hebben altijd *veel mensen* gewoond *met financiële problemen*.  
 here have always many people lived with financial problems  
 ‘Many people with financial problems have lived here over time.’

The problem that the acceptability of the examples in (85) to (87) poses for the raising analysis is that this analysis presupposes that relative clauses can appear postverbally only if the noun phrases they modify are base-generated in a position following the surface position of the clause-final verbs. While this is plausible for objects, this is quite unlikely for subjects: assuming that the subject in (85c) is base-generated to the right of the surface position of the main verb is incompatible with the standard assumption presented in Section 9.2 that the clause-final verb is located within VP and thus follows the base position of the external argument (subject) of the main verb. The raising analysis therefore makes it necessary to revise the standard analysis of Dutch clauses, which should not be done light-heartedly; see also Koster (2000:8). Note in passing that the so-called scattered deletion approach proposed in Wilder (1995) and Sheehan (2010), which we did not discuss here, has the same flaw (which is in fact presented as a virtue by Sheehan on the basis of English data); we refer the reader to De Vries (2002:ch.7) for a more extensive review of this approach.

A problem for either proposal in (79) is that extraposition is also possible from a noun phrase that does not function as a clausal constituent itself but is *embedded in a clausal constituent*. This is illustrated in (88) for cases in which the noun phrases function as the complement of a prepositional object.

- (88) a. Jan heeft [op [die man [die hem wil helpen]]] gewacht.  
 Jan has for that man who him wants help waited  
 ‘Jan has waited for that man who wants to help him.’
- a’. Jan heeft [*op die man*] gewacht *die hem wil helpen*.
- b. Jan moet [op [de bevestiging [dat hij mag komen]]] wachten.  
 Jan must for the confirmation that he may come wait  
 ‘Jan has to wait for the confirmation that he is allowed to come.’
- b’. Jan moet [*op de bevestiging*] wachten *dat hij mag komen*.
- c. Jan heeft [op [die man <met het aapje>]] gewacht.  
 Jan has for that man with the monkey waited  
 ‘Jan has waited for that man with the monkey.’
- c’. Jan heeft [*op die man*] gewacht *met het aapje*.

The problem for the extraposition analysis in (79a) is that we must assume that the extraposed phrase is extracted, not just from a noun phrase but also from the containing PP: cf. ... [PP P [NP ... N  $t_i$ ]] ... V [REL-clause/clause/PP]<sub>i</sub>. The fact that examples such as \**Wie<sub>i</sub> wacht je [PP op  $t_i$ ]*? ‘Who are you waiting for?’ are unacceptable shows that Dutch PPs normally behave as islands for movement, and



this makes the extraposition analysis quite implausible because the extraposed phrase is not only extracted from a noun phrase but also from a PP. The problem with the raising approach is of a different nature: the presumed leftward movement involves the non-constituent *op die man* (cf. [PP *op* [NP *die man* [REL-CLAUSE *die ...*]]]). Under normal circumstances we would expect that movement of this PP cannot strand the postnominal phrase. It should be noted, however, that this argument only applies to theories that assume that the PP is base-generated as a unit; if we assume that complement-PPs are created in the course of the derivation, as suggested by Kayne (2004), this problem need not arise.

It is also generally assumed that extraposition is possible from noun phrases that are embedded in a postnominal PP, although there seem to be several restrictions on this option that are not yet well understood. Example (89a) has two alternating versions with extraposition. The first version is given in (89b) and simply involves extraposition of a postnominal PP from a direct object. The second alternant, which is given in (89c), is the one that is relevant here: it involves extraposition of a relative clause from a noun phrase that is embedded in a postnominal modifier (as is clear from the fact that the relative pronoun *die* cannot take the noun *boek* as antecedent because it does not agree with it in gender (cf. *Het boek dat ik gelezen heb* ‘the book I have read’), and thus must be construed with the noun *plaatjes*).

- (89) a. dat Jan [een boek [met plaatjes [die ingekleurd zijn]]] heeft gekocht.  
 that Jan a book with pictures which colored are has bought  
 ‘that Jan has bought a book with colored pictures.’  
 b. dat Jan *een boek* heeft gekocht *met plaatjes die ingekleurd zijn*.  
 that Jan a book has bought with pictures which colored are  
 c. <sup>(?)</sup>dat Jan *een boek met plaatjes* heeft gekocht *die ingekleurd zijn*.  
 that Jan a book with pictures has bought which colored are

Example (89c) is perhaps slightly marked compared to (89b), but seems fully acceptable; the contrast may be computational in nature in the sense that speakers simply tend to connect extraposed relative clauses to the (structurally) closest antecedent. In (89c), this is, of course, the nominal projection *een boek met plaatjes*, and not the more deeply embedded phrase *plaatjes*. For one reason or another, this effect seems stronger if the extraposed phrase is of the same category as the postnominal modifier. This is illustrated in (90) for PPs.

- (90) a. dat Jan [een boek [met plaatjes [in kleur]]] heeft gekocht.  
 that Jan a book with pictures in color has bought  
 ‘that Jan has bought a book with colored pictures.’  
 b. dat Jan *een boek* heeft gekocht *met plaatjes in kleur*.  
 that Jan a book has bought with pictures in color  
 c. <sup>?</sup>dat Jan *een boek met plaatjes* heeft gekocht *in kleur*.  
 that Jan a book with pictures has bought in color

Example (90c) is reasonably acceptable but there are cases with a similar structure that are judged infelicitous by at least some speakers: see Haeseryn et al. (1997:1381ff.) for a range of cases which they claim resist split extraposition of the

kind under discussion; see Johnson (1991: section 3.3.4 for similar data from English. Examples such as (91c), for instance, are given as unacceptable, although some of our informants consider them fairly acceptable, which we have indicated by a percentage sign.

- (91) a. dat Jan [een boek [met foto's [van zijn hond]]] heeft.  
 that Jan a book with pictures of his dog has  
 'that Jan has a book with pictures of his dog.'
- b. dat Jan *een boek* heeft *met foto's van zijn hond*.  
 that Jan a book has with pictures of his dog
- c. % dat Jan *een boek met foto's* heeft *van zijn hond*.  
 that Jan a book with pictures has of his dog

Although it is unclear to us what determines whether extraposition of a more deeply embedded PP leads to a generally accepted result or not, we conjecture that the restrictions are not of a syntactic nature, but that considerations of processing, semantic coherence, prosody, etc. are involved; because we are not aware of any in-depth investigations of this, we have to leave this to future research. If our provisional conclusion that all the (c)-examples in (89) to (91) are syntactically well-formed turns out to be well-founded, it would lead to problems of the kind that were already pointed out for the examples in (88). This time we are not aware of any existing proposal that can be utilized to solve the problem for the raising analysis. For completeness' sake, note that the scattered deletion approach, which we dismissed earlier, *would* be able to handle this problem; see De Vries (2002:ch.7) for this.

Finally, we want to point out that the split extraposition pattern is also possible if the noun phrase is the complement of a locational/temporal adverbial PP; this is illustrated in (92) by means of a relative clause. The acceptability of the primed examples is again a severe problem for the movement analyses in (79), as such adverbial phrases are often considered to be absolute islands for movement. In addition, the raising approach is problematic because it requires the adjunct PPs to be base-generated postverbally and to be moved into their preverbal surface position, while there are good reasons for assuming the opposite: that the adverbial phrase is base-generated in preverbal position can be supported by the fact that this is the unmarked position for non-prepositional adverbial phrases like *morgen* 'tomorrow' and *gisteren* 'yesterday'; see Section 12.3, sub IV. Note in passing that this problem also holds for the scattered deletion approach mentioned earlier.

- (92) a. Ik heb Els [tijdens [een workshop [waar zij een lezing gaf]]] gezien.  
 I have Els during a workshop where she a talk gave seen  
 'I saw Els during a workshop where she gave a talk.'
- a'. Ik heb Els *tijdens een workshop* gezien *waar zij een lezing gaf*.  
 I have Els during a workshop seen where she a talk gave
- b. Ik heb Els voor het laatst [in [een park [waar ik vaak kom]]] gezien.  
 I have Els for the last.time in a park where I often come seen  
 'The last time I saw Els was in a park I like to frequent.'
- b'. Ik heb Els voor het laatst *in een park* gezien *waar ik vaak kom*.  
 I have Els for the last.time in a park seen where I often come

All things considered, we may conclude from the data in this subsection that the split extraposition pattern cannot be accounted for by the two movement analyses in (79); these proposals can only be maintained if we allow the proposed movements to violate otherwise well-motivated island constraints on movement. The raising (as well as the scattered deletion) approach furthermore requires that we adopt the quite unorthodox claim that the external °argument ( $\approx$  subject) of the verb has a base-position that is structurally lower than (or, in linear terms, to the right of) the surface position of the clause-final verb.

## II. Other cases of split extraposition

Subsection I has illustrated the split extraposition pattern for nominal phrases. Although this is the prototypical case, it has been known for a long time that the split also occurs with other categories; cf. Koster (1974). We illustrate this in (93a) for complementive adjectival phrases with a PP-complement. It should be noted that such cases cannot easily be used to argue against a movement analysis of extraposition because the PP-complements can also be moved leftwards, as is illustrated in the primed examples by means of topicalization.

- (93) a. dat Marie [<sub>AP</sub> erg boos <op Peter>] is <op Peter>.  
           that Marie     very angry   at Peter    is  
           ‘that Marie is very angry with Peter.’  
       a'. [Op Peter]<sub>i</sub> is Marie [<sub>AP</sub> erg boos t<sub>i</sub>].  
           at Peter     is Marie     very angry  
       b. dat Jan [<sub>AP</sub> erg dol <op chocola>] is <op chocola>.  
           that Jan     very fond   of chocolate is  
           ‘that Jan is very fond of chocolate.’  
       b'. [Op chocola]<sub>i</sub> is Jan [<sub>AP</sub> erg dol t<sub>i</sub>].  
           of chocolate is Jan     very fond

Things are different if the extraposed phrase is part of a modifier of the adjective. This is illustrated in (94) by means of the discontinuous degree phrase *zo ... dat hij overal past* ‘so .. that it fits everywhere’. Despite the fact that A3.1.3.1, sub II, has shown that the finite degree phrase is part of the AP (they can be extraposed together), it is preferably in extraposed position; placing the clause in the position preceding the copular verb *zijn* gives rise to a quite marked result. Nevertheless, the fact illustrated by (94b) that the degree clause cannot be topicalized in isolation strongly suggests that it cannot be extracted from the AP; cf. Rijkhoeck (1998).

- (94) a. dat de computer zo klein is dat hij overal past.  
           that the computer so small is that he everywhere fits  
           ‘that the computer is so small that it fits everywhere.’  
       b. \*Dat hij overal past is de computer zo klein.

The unacceptability of (94b) thus suggests again that the split extraposition pattern in (94a) is not island-sensitive. This is further supported by the examples in (95), which show that the AP can easily be more deeply embedded: in (94b) the split AP is part of a direct object and in (94c) it is part of a PP-object.

- (95) a. dat Jan [een *zo kleine* computer] wil hebben *dat hij overal past*.  
 that Jan a so small computer want have that he fits everywhere  
 ‘that Jan wants to have such a small computer that it fits everywhere.’  
 b. dat Jan [naar [een *zo kleine* computer]] zoekt *dat hij overal past*.  
 that Jan for a so small computer looks that he fits everywhere  
 ‘that Jan is looking for such a small computer that it fits everywhere.’

That extraposition of degree clauses is not island-sensitive is also clear from the fact that they can be associated with modified manner adverbs such as *hard* ‘loud’ in (96), despite the fact that such adverbial phrases are often considered to be absolute islands for movement.

- (96) dat de band *zo hard* speelt *dat je elkaar niet kan verstaan*.  
 that the band so loudly plays that one each.other not can hear  
 ‘that the band plays so loudly that you can’t hear each other.’

We find essentially the same with *dan/als*-phrases accompanying comparatives; see Section A4. The examples in (97) first show that despite the fact that the *dan/als*-phrases cannot be topicalized, the split extraposition pattern is possible (and perhaps even preferred). This again suggests that split extraposition is not island-sensitive.

- (97) a. dat zijn computer minder snel <dan de mijne> is <dan de mijne>.  
 that his computer less fast than the mine is  
 ‘that his computer is less fast than mine.’  
 b. \**Dan de mijne* is zijn computer *minder snel*.

More support comes from the fact that the comparative can easily be more deeply embedded: in (98a) the split AP is part of a direct object and in (98b) it is part of a PP-object.

- (98) a. dat Jan [een *snellere* computer] wil hebben *dan de mijne*.  
 that Jan a faster computer wants have than the mine  
 ‘that Jan wants to have a faster computer than mine.’  
 b. dat Jan [naar [een *snellere* computer]] zoekt *dan de mijne*.  
 that Jan for a faster computer looks than the mine  
 ‘that Jan is looking for a faster computer than mine.’

That extraposition of *dan/als*-phrases is not sensitive to islands is also clear from the fact that they can be associated with modified manner adverbs such as *sneller* ‘faster’ in (99), despite the fact that such adverbial phrases are often considered to be absolute islands for movement.

- (99) dat Jans computer *sneller* werkt *dan de mijne*.  
 that Jan’s computer faster works than the mine  
 ‘that Jan’s computer works more quickly than mine.’

For completeness’ sake, observe that split extraposition is not possible in the case of attributively used adjectives. This is illustrated by means of the examples in (100); while the PP-complement of the adjective *verliefd* can be extraposed if the AP is used as a complementive, it cannot if it is used as an attributive modifier.

- (100) a. dat Jan verliefd <op Marie> is <op Marie>.  
 that Jan in-love with Marie is  
 'that Jan is in love with Peter.'
- b. dat ik een <op Peter> verliefde jongen ontmoette <\*op Peter>.  
 that I a with Marie in.love boy met  
 'that I met a boy who is in love with Peter.'

### III. VP-topicalization

Subsections I and II have shown that split extraposition is not sensitive to islands for extraction, which suggests that we are not dealing with movement, which subsequently raises the question as to what extraposition is. One possibility is that we are dealing with right dislocation. This does not seem the correct solution, however, given that Section 12.1, sub IV, has shown that right-dislocated phrases have a tendency of stranding under VP-topicalization, while postverbal phrases in split extraposition constructions tend to be pied piped, as illustrated in (101) for extraposed postnominal phrases. Observe that the primed examples *are* acceptable with the typical intonation contour of an afterthought, that is, with an intonation break and an additional accent in the phrase following this break. This would suggest that while the dislocated phrases are external to the preposed verbal projection, the extraposed phrases in (101) are internal to it. Recall from the introduction to this section that the nominal phrase in preverbal position must also be pied piped in order to arrive at an acceptable result (Kaan's generalization); this is, of course, expected given that Subsection I has shown that scrambling blocks the split extraposition pattern.

- (101) a. [*De man kennen die dit boek geschreven heeft*] doet hij niet.  
 the man know who this book written has does he not  
 'He doesn't know the man who has written this book.'
- a'. [*De man kennen*] doet hij niet \*(,) *die dit boek geschreven heeft*.
- b. [*De bewering weerleggen dat Marie gelogen had*] kon hij niet.  
 the assertion rebut that Marie lied had could he not  
 'He couldn't rebut the claim that Marie had lied.'
- b'. [*De bewering weerleggen*] kon hij niet \*(,) *dat Marie gelogen had*.
- c. [*De man gezien met het aapje*] heeft hij niet.  
 the man seen with the monkey has he not  
 'He hasn't seen the man with the monkey.'
- c'. [*De man gezien*] heeft hij niet \*(,) *met het aapje*.

The examples in (102) show essentially the same as the examples in (101) but now we are dealing with cases in which the split noun phrase is embedded in a PP-object. In accordance with Kaan's generalization, pied piping of the extraposed phrase requires the PP to be pied piped as well, as in the primeless examples. As in the case of nominal objects the full PP can be stranded under VP-topicalization: cf. *Gewacht heeft Jan niet op die man die hem wil helpen*.

- (102) a. [*Op die man gewacht die hem wil helpen*] heeft Jan niet.  
 for that man waited who him wants help has Jan not  
 'Jan hasn't waited for that man who wants to help him.'
- a'. [*Op die man gewacht*] heeft Jan niet \*(,) *die hem wil helpen*.

- b. [*Op de bevestiging* gewacht *dat hij mag komen*] heeft Jan niet.  
for the confirmation waited that he may come has Jan not  
'Jan hasn't waited for the confirmation that he is allowed to come.'
- b'. [*Op de bevestiging* gewacht] heeft Jan niet \*(,) *dat hij mag komen*.
- c. [*Op de man* gewacht *met het aapje*] heeft Jan niet.  
for the man waited with the monkey has Jan not  
'Jan hasn't waited for the man with the monkey.'
- c'. [*Op de man* gewacht] heeft Jan niet \*(,) *met het aapje*.

The examples in (103) illustrate the same again but now for split APs. The degraded status of (103a'') is especially telling as *dol* meaning "fond (of)" obligatorily takes an *op*-PP as its complement, and we have seen in Subsection IC that such obligatory PPs can only be right-dislocated if a pronominal PP is present in preverbal position. Note in passing that in accordance with Kaan's generalization the complementive and the manner adverb in the singly-primed examples cannot be stranded under VP-topicalization; this is expected given that this also holds for cases of VP-topicalization with a simple adjective: cf. *Hard spelen zal de band niet* versus *\*Spelen zal de band <hard> niet <hard>*.

- (103) a. Ik ben mijn hele leven [*dol <op chocola>*] gebleven <op chocola>.  
I am my whole life fond of chocolate stayed  
'I have remained fond of chocolate my whole life.'
- a'. [*Dol* gebleven *op chocola*] ben ik mijn hele leven.'
- a''. *\*[Dol* gebleven] ben ik mijn hele leven (,) *op chocola*.
- b. De band zal niet zo hard spelen dat je elkaar niet kan verstaan.  
the band will not so loudly play that you each.other not can hear  
'The band won't play so loudly that you can't hear each other.'
- b'. [*Zo hard spelen dat je elkaar niet kan verstaan*] zal de band niet.
- b''. [*Zo hard spelen*] zal de band niet \*(,) *dat je elkaar niet kan verstaan*.

For completeness' sake we conclude by providing similar examples in (104) with a comparative *dan/als*-phrase.

- (104) a. [*Een snellere computer vinden dan de mijne*] kon hij niet.  
a faster computer find than the mine could he not  
'He couldn't find a faster computer than mine.'
- a'. *\*[Een snellere computer vinden ]* kon hij niet *dan de mijne*.
- b. [*Sneller werken dan de mijne*] doet Jans computer niet.  
faster work than the mine does Jan's computer not  
'Jan's computer doesn't work faster than mine.'
- b'. *\*[Sneller werken ]* doet Jans computer niet *dan de mijne*.

The examples above show that extraposed phrases in the split extraposition construction differ from right-dislocated clauses in that they are internal to the preposed verbal projection. Consequently, we are in need of another non-movement account for the split extraposition pattern.

IV. An alternative analysis

Koster (1995/2000) proposes to analyze split extraposition as a form of juxtaposition. The initial motivation for this was that we find the split pattern also in coordinate structures; a movement analysis of an example such as (105a) would go against the °coordinate structure constraint, which is held to be universally valid. De Vries (2002) further claimed that split coordination resembles split extraposition in that the postverbal part can be pied piped under VP-topicalization, and we do indeed detect a sharp contrast between the pied piping case in (105b) and the stranding case in (105b'), which is severely degraded (even if the second part of the conjunction is preceded by an intonation break). The percentage sign in (105b) is used to indicate that while De Vries gives this example as fully acceptable, we find the result somewhat marked.

- (105) a. Marie heeft [Jan <en Peter>] bezocht <en Peter>.  
 Marie has Jan and Peter visited  
 'Marie has visited Jan and Peter.'
- b. % [Jan bezocht en Peter] heeft Marie niet.  
 Jan visited en Peter has Marie not
- b'. \* [Jan bezocht] heeft Marie niet (,) en Piet.  
 Jan visited has Marie not and Piet

That the split pattern cannot be derived by movement is also made clear when considering subjects: while the non-split pattern in (106a) triggers plural agreement on the finite verb, the split pattern in (106b) does not; Koster (2000) notes that this would be unexpected if (106b) were derived from (106a) by movement.

- (106) a. Jan en Peter hebben/\*heeft dit boek gelezen.  
 Jan and Peter have/has this book read  
 'Jan and Peter have read this book.'
- b. Jan heeft/\*hebben dit boek gelezen en Peter.  
 Jan has/have this book read and Peter  
 'Jan has read this book and Peter.'

Another unexpected fact under the movement approach is that while the non-split-pattern is subject to the coordinate structure constraint, which prohibits extraction of/from a single conjunct, the split pattern is not subject to this constraint. This is illustrated by the contrast between the two (b)-examples in (107).

- (107) a. Zij heeft [Jan <en Peter>] bezocht <en Peter>.  
 she has Jan and Peter visited  
 'She has visited Jan and Peter.'
- b. \*Jan<sub>i</sub> heeft zij [<sub>t<sub>i</sub></sub> en Peter] bezocht.
- b'. Jan<sub>i</sub> heeft zij <sub>t<sub>i</sub></sub> bezocht en Peter.

Koster proposes that the split patterns differ from the non-split patterns in that they do not involve coordination of equals, as in (108a), but rather have the form in (108b) where the equal of the second conjunct is embedded in a larger phrase. The split pattern may involve coordination of various verbal projections (VP, TP, or CP) and a noun phrase, as indicated in (108b). Note in passing that in cases like (108b)



the second conjunct is actually external to the clause, for which reason we may analyze this as a kind of right dislocation; we ignore this issue here and refer the reader to Section 14.3, sub VII, for a brief discussion of a proposal which would imply this.

- (108) a. [XP & XP], e.g., [Jan en Peter]  
 b. [[<sub>VP</sub> ... XP ...] & XP]  
 i. Marie heeft [[<sub>VP</sub> Jan bezocht] en Peter].  
 ii. [[<sub>TP</sub> Jan heeft dit boek gelezen] en Peter].  
 iii. [[<sub>CP</sub> Jan<sub>i</sub> heeft zij <sub>t<sub>i</sub></sub> bezocht] en Peter].

The form of coordination in (108b) raises a lot of questions, especially the fact that the two conjuncts are not parallel in categorial status, syntactic function and meaning. We will not go into this here, because De Vries (1999/2002) has proposed an alternative, according to which we are dealing with coordination of two verbal projections plus deletion of identical material. According to this proposal, the three examples in (108b) receive the representations in (109).

- (109) a. VP & VP: Marie heeft [[<sub>VP</sub> Jan bezocht] en [<sub>VP</sub> Peter ~~bezoekt~~]].  
 b. IP & IP: [[<sub>IP</sub> Jan heeft dit boek gelezen] en [<sub>IP</sub> Peter ~~heeft dit boek gelezen~~]].  
 c. CP & CP: [[<sub>CP</sub> Jan<sub>i</sub> heeft zij <sub>t<sub>i</sub></sub> bezocht] en [<sub>CP</sub> Peter<sub>i</sub> ~~heeft zij <sub>t<sub>i</sub></sub> bezoekt~~]].

Note in passing that structures such as (109c) will be analyzed as right dislocations in Section 14.3 but in order to not complicate the discussion we will ignore this issue here, while noting that we cannot apply the VP-topicalization test to this case so that there is no syntactic evidence to reject the right dislocation analysis here.

The hypothesis put forward by Koster is that split extraposition is a specific case of PARALLEL CONSTRUCTION; this notion refers to a larger set of structures in which two (or more) elements are juxtaposed and in which the second phrase specifies the first. For concreteness' sake, we will follow De Vries who argues that the split extraposition pattern can also be analyzed as asyndetic specifying coordination plus ellipsis; see also Bianchi (1999:264ff.). The primed examples in (110) illustrate his analysis of split extraposition for a direct object; the element &: marks a phonetically empty conjunction with a specifying meaning.

- (110) a. Jan heeft *de man* ontmoet *die hem wil helpen*.  
 Jan has the man met who him wants help  
 'Jan has met the man who wants to help him.'  
 a'. Jan heeft [[<sub>VP</sub> *de man* ontmoet] &: [<sub>VP</sub> ~~*de man die hem wil helpen*~~ ontmoet]].  
 b. Jan heeft *veel mensen* ontmoet *met financiële problemen*.  
 Jan has many people met with financial problems  
 'Jan has met many people with financial problems.'  
 b'. Jan heeft [[<sub>VP</sub> *veel mensen* ontmoet] &: [<sub>VP</sub> ~~*veel mensen met financiële problemen*~~ ontmoet]].

Given that the examples in (111) show that ellipsis may affect subparts of phrases and words, it does not come as surprise that split extraposition is also able to affect subparts of phrases like the relative clause and postnominal modifier in (110).

- (111) a. [Jan zit [links ~~van Peter~~] en [Els zit [rechts van Peter]].  
 Jan sits to.the.left of Peter and Els sits to.the.right of Peter  
 ‘Jan is sitting to the left and Els is sitting to the right of Peter.’  
 b. [[~~invoer~~] and [uitvoer]]  
 import and export

Following this line of reasoning, we can expect that the extraposed phrase may originate in quite deeply embedded positions. This is illustrated in (112a) for split extraposition involving a noun phrase that functions as the complement of a prepositional object and in (112b) of a noun phrase that is part of a postnominal modifier.

- (112) a. Jan heeft op *die man* gewacht *die hem wil helpen*.  
 Jan has for that man waited who him wants help  
 ‘Jan has waited for that man who wants to help him.’  
 a'. Jan heeft [[VP [PP op *die man*] gewacht] &: [VP [PP ~~op die man~~ *die hem wil helpen*] ~~gewacht~~]].  
 b. Jan heeft *een boek met plaatjes* gekocht *die ingekleurd zijn*.  
 Jan has a book with pictures bought which colored are  
 ‘Jan has bought a book with colored pictures.’  
 b'. Jan heeft [[VP [NP een boek [PP met plaatjes]] gekocht] &: [VP [NP ~~een boek~~ [PP ~~met plaatjes~~ [REL-clause *die ingekleurd zijn*]]] ~~gekocht~~]].

Another advantage of De Vries’ analysis is that it can account for the fact shown in (113) that the extraposed phrase obeys selection restrictions imposed by its associate, for the simple reason that the two form a unit in the second conjunct. It is not immediately clear how Koster’s proposal could account for this.

- (113) a. Jan heeft de hoop <op/\*voor hulp> verloren <op/\*voor hulp>.  
 Jan has the hope on/for help lost  
 ‘that Jan has lost all hope of help.’  
 b. Jan heeft [[VP [NP de hoop] verloren] &: [VP [NP ~~de hoop~~ [PP op hulp]] ~~verloren~~]].

Furthermore, De Vries’ analysis immediately derives the fact that the extraposed part of the “split” phrase cannot be stranded. The primed representations in (110) and (112) show that stranding can only be derived by moving the first conjunct (here: VP) of the coordinate structure, but this would violate the coordinate structure constraint. Given that this constraint also prohibits subextraction from one of the conjuncts, we may have a principled account for Kaan’s generalization that it is impossible to pied piped the postverbal part while stranding the preverbal part (thus making an appeal to Guéron’s semantic restriction on split extraposition unnecessary). Finally, we can also derive Ross’ (1967) Right Roof Constraint on extraposition illustrated in (114), according to which the postverbal part cannot be “moved” out of its own minimal finite clause. The reason is that coordination always involves clause-internal elements; example (114b) is excluded because the reduced phrase [VP [NP ~~de vrouw~~ *die hier net was*] ~~kent~~] cannot be coordinated with the VP of the topicalized clause.

- (114) a. [<sub>Clause</sub> Dat hij *de vrouw* kent *die hier net* was] is duidelijk.  
 that he the woman knows who here just.now was is clear  
 ‘It is clear that he knows the woman who was here just now.’  
 b. \*<sub>Clause</sub> [Dat hij *de vrouw* kent] is duidelijk *die hier net was*.

A potential drawback of De Vries’ proposal is that it requires *forward* deletion (deletion in the second conjunct) of material in the right periphery of the second conjunct, while this type of °conjunction reduction can only be applied backwards, as is clear from the contrast between (115a&b).

- (115) a. [[Jan heeft een boek ~~gekocht~~] en [Marie heeft een CD gekocht]].  
 Jan has a book bought and Marie has a CD bought  
 ‘Jan has bought a book and Marie has bought a CD.’  
 b. \*[[Jan heeft een boek gekocht] en [Marie heeft een CD ~~gekocht~~]].  
 Jan has a book bought and Marie has a CD bought

It should be noted, however, that there are also cases which perhaps can be analyzed as forward deletion. De Vries (2011a/2011b) provides examples such as (116).

- (116) a. [Jan heeft een boek gekocht] en [Marie ~~heeft ook een boek gekocht~~].  
 Jan has a book bought and Marie has also a book bought  
 ‘Jan has bought a book and Marie has too.’  
 b. [Jan heeft een boek gekocht] en [Marie ~~heeft~~ een CD gekocht].  
 Jan has a book bought and Marie has a CD bought  
 ‘Jan has bought a book and Marie a CD.’

Vanden Wyngaerd (2011) points out that unifying the deletion operation postulated in the derivation of extraposition with the deletion operation that derives the so-called gapping construction in (116b) overgenerates: the remnants in the gapping constructions are normally clausal constituents and not *parts* of clausal constituents; cf. Hankamer (1971) and Neijt (1979:ch.3). Unifying the two deletion operations thus wrongly predicts the gapping constructions in (117) to be acceptable. We will leave this issue to future research and refer the reader to the discussion between De Vries and Vanden Wyngaerd for more details.

- (117) a. \*<sub>Clause</sub> [Jan heeft *het gerucht* gehoord *dat Marie zwanger* is] en  
 Jan has the rumor heard that Marie pregnant is and  
 [Peter ~~heeft het gerucht gehoord~~ dat Els bevallen is].  
 Peter has the rumor heard that Els given.birth is  
 Intended reading: ‘Jan has heard the rumor that Marie is pregnant and Peter has heard the rumor that Els has given birth.’  
 b. \*<sub>Clause</sub> [Jan heeft meer artikelen gelezen dan boeken] en  
 Jan has more articles read than books and  
 [Peter ~~heeft meer artikelen gelezen~~ dan recensies].  
 Peter has more articles read than reviews  
 Intended reading: ‘Jan has read more articles than books and Peter has read more articles than reviews.’

V. Conclusion

This subsection has shown that there are several problems in analyzing split extraposition as the result of movement analyses. We therefore concluded our discussion by introducing fairly recent proposal, according to which split extraposition is actually a form of juxtaposition (with or without deletion). The approach seems to be relatively successful in deriving the basic facts; it is not surprising therefore that attempts are being made to derive a wider range of data from the same mechanism: non-split extraposition (Koster 1995/1999), appositional constructions (Heringa 2012), contrastive left dislocation (Ott 2014), backgrounding right dislocation (De Vries & Ott 2012 and Ott & De Vries 2015), etc. We will return in Sections 14.2 and 14.3 to the cases of left and right dislocation.

12.5. Word order

This section discusses a number of tendencies concerning word order in the postverbal field. We will restrict our attention to the order of arguments and adverbial modifiers, and refer the reader to Section N3.3.2 for a more extensive discussion of word order restrictions on relative clauses in extraposed position.

I. The position of argument clauses

This subsection discusses the placement of argument clauses with respect to other extraposed phrases. Since Koster (1974) it has generally been assumed that extraposed phrases exhibit a MIRROR EFFECT; their relative order is the inverse of what we find in the middle field of the clause. We illustrate this effect for the order of argument clauses with respect to other arguments and adverbial phrases. With regard to adverbial phrases a problem arises in the sense that, although the mirror effect does arise with adverbial clauses, it does not seem to be required in the case of adverbial PPs.

A. Placement with respect to other arguments

Clausal arguments normally follow other postverbal arguments. This is illustrated in (118) for a direct object clause: it follows the prepositional indirect object *aan Peter* and the PP-complement *tegen Peter*. The relative orders of the arguments found in these examples clearly illustrate the mirror effect, as they are clearly the inverse of what we find in the middle field of the clause, where the direct object normally precedes the PP: cf. *dat Jan dat verhaal aan Peter vertelde* ‘that Jan told that story to Peter’ and *dat Jan die dingen tegen Peter gezegd had* ‘that Jan said these things to Peter’.

- (118) a. dat Jan <aan Peter> vertelde <aan Peter> [dat Marie zou komen].  
 that Jan to Peter told that Marie would come  
 ‘that Jan told Peter that Marie would come.’  
 a’. <sup>\*?</sup> dat Jan vertelde [dat Marie zou komen] aan Peter.  
 b. dat Jan <tegen Peter> zei <tegen Peter> [dat Marie zou komen].  
 that Jan to Peter said that Marie would come  
 ‘that Jan said to Peter that Marie would come.’  
 b’. <sup>\*?</sup> dat Jan zei [dat Marie zou komen] tegen Peter.

That argument clauses follow prepositional objects does not only hold for object but also for subject clauses, which resemble object clauses in that they originate as internal °arguments; see Section 5.1.3, where it is shown that subject clauses normally do not occur in (in)transitive unaccusative constructions. We illustrate this by means of the passive counterparts of the (a)-examples in (118); cf. *dat dit verhaal aan Peter verteld werd* ‘that this story was told to Peter’ and *dat die dingen tegen Peter gezegd werden* ‘that these things were said to Peter’.

- (119) a. dat er <aan Peter> verteld werd <aan Peter> [dat Marie zou komen].  
 that there to Peter told was that Marie would come  
 ‘that Peter was told that Marie would come.’  
 a’. \*dat er verteld werd [dat Marie zou komen] aan Peter.  
 b. dat er <tegen Peter> gezegd werd <tegen Peter> [dat Marie zou komen].  
 that there to Peter said was that Marie would come  
 ‘that they said to Peter that Marie would come.’  
 b’. \*dat er gezegd werd [dat Marie zou komen] tegen Peter.

Because subject and object clauses normally originate as internal arguments, there are only a few cases in which they co-occur. In the rare cases that this does happen, the relative order of the subject and the object clause cannot easily be determined because De Haan (1974) has shown that in such cases the subject clause tends to be placed in clause-initial position. He even claims that it is impossible to place the subject clause in postverbal position. This may be an overstatement, as the sharp contrast between the two (b)-examples in (120) indicates that the primeless example is relatively well-formed.

- (120) a. [Dat hij niet klaagt] zal wel betekenen [dat hij gelukkig is].  
 that he not complains will PRT mean that he happy is  
 ‘that he doesn’t complain probably means that he is happy.’  
 b. %Het zal wel betekenen [dat hij gelukkig is], [dat hij niet klaagt].  
 it will PRT mean that he happy is that he not complains  
 b’. \*Het zal wel betekenen [dat hij niet klaagt], [dat hij gelukkig is].  
 it will PRT mean that he not complains that he happy is

The contrast between the two (b)-examples could be seen as another instantiation of the mirror effect but it should be noted that postverbal placement of the subject clause requires the subject position to be filled by the anticipatory pronoun *het* ‘it’. This suggests that the “subject” clause is actually not an argument clause but a clausal apposition in right-dislocated position; cf. Section 12.2, sub IB, and this suggests that we should put cases like (120b) aside from our present discussion. Another reason to do this is that the subject clause may actually be nominal in nature, as it can readily be replaced by the noun phrase *het feit dat hij niet klaagt* ‘the fact that he doesn’t complain’.

### *B. Placement with respect to adverbial clauses*

Argument clauses normally precede adverbial clauses. This is illustrated in (121) for adverbial clauses expressing, respectively, time and reason; the primed examples are possible only if the adverbial clause is interpreted parenthetically, in

which case it must be preceded and followed by an intonation break. Note in passing that the strings in the primeless examples are ambiguous in speech, as the adverbial clauses may also be construed as part of the object clause, in which case they refer to the time at which/the reason why the resignation will take place.

- (121) a. Jan zal ons vertellen [dat hij zal aftreden] [zodra hij hier is].  
 Jan will us tell that he will prt.-resign as.soon.as he here is  
 'Jan will tell us that he'll resign as soon as he's here.'
- a'. #Jan zal ons vertellen [zodra hij hier is] [dat hij zal aftreden].
- b. Jan zal ons vertellen [dat hij zal aftreden] [omdat hij integer is].  
 Jan will us tell that he will prt.-resign because he honest is  
 'Jan will tell us that he'll resign because he is honest.'
- b'. #Jan zal ons vertellen [omdat hij integer is] [dat hij zal aftreden].

The order restriction illustrated in (121) is again an instantiation of the mirror effect. This becomes apparent as soon as one realizes that object clauses are normally part of the focus (new information) of the clause and that adverbial clauses tend to precede the focus of the clause when they are located in the middle field of the clause; we illustrate this in (122) by means of the non-specific indefinite nominal object *iets belangrijks* 'something important'. The mirror effect thus correctly predicts the primed examples in (121) to be excluded.

- (122) a. Jan zal ons [zodra hij hier is] iets belangrijks vertellen.  
 Jan will us as.soon.as he here is something important tell  
 'Jan will tell us something important as soon as he is here.'
- a'. \*Jan zal ons iets belangrijks [zodra hij hier is] vertellen.
- b. Jan zal ons [omdat hij ons waardeert] iets belangrijks vertellen.  
 Jan will us because he us appreciates something important tell  
 'Jan will tell us something important because he appreciates us.'
- b'. \*Jan zal ons iets belangrijks [omdat hij ons waardeert] vertellen.

Subject clauses behave in a similar fashion as object clauses, and for the same reasons. The examples in (123) illustrate this by means of the passive counterparts of the (a)-examples in (121) and (122). Note that the strings in the primeless examples are ambiguous in speech again, as the adverbial clauses may also be construed as part of the object clause.

- (123) a. Ons zal verteld worden [dat hij zal aftreden] [zodra hij hier is].  
 us will told be that he will prt.-resign as.soon.as he here is  
 'We will be told that he will resign as soon as he's here.'
- a'. #Ons zal verteld worden [zodra hij hier is] [dat hij zal aftreden].
- b. Ons zal [zodra hij hier is] iets belangrijks verteld worden.  
 us will as.soon.as he here is something important told be  
 'We will be told something important as soon as he is here.'
- b'. \*Ons zal iets belangrijks [zodra hij hier is] verteld worden.

*C. Placement with respect to prepositional adverbial phrases*

The examples in (124) provide similar cases as the ones in (121) with a temporal and a locational PP, but here the judgments are much less clear: the primed examples all seem acceptable, with a preference for the order in the doubly primed examples, in which the adverbial PPs *precede* the object clauses. This may be due to the fact that in speech the PP tends to be construed as part of the object clause; the much-preferred order seems to be the ones in the primeless examples, with the PPs in preverbal position.

- (124) a. dat Jan [na het gesprek] dacht [dat hij de baan zou krijgen].  
 that Jan after the interview thought that he the job would get  
 ‘that Jan thought after the interview that he would get the job.’  
 a’. dat Jan dacht [dat hij de baan zou krijgen] [na het gesprek].  
 a’’. dat Jan dacht [na het gesprek] [dat hij de baan zou krijgen].  
 b. dat Jan [in de bus] vreesde [dat hij ziek werd].  
 that Jan in the bus feared that he ill became  
 ‘that Jan was afraid in the bus that he would become ill.’  
 b’. dat Jan vreesde [dat hij ziek werd] [in de bus].  
 b’’. dat Jan vreesde [in de bus] [dat hij ziek werd].

We see that the examples in (124) do not exhibit the mirror effect found in the earlier examples. This is perhaps not surprising given that direct object clauses also tend to follow adverbial phrases of other categories. Example (125b), for instance is only acceptable with an afterthought intonation contour; the modal adverb *waarschijnlijk* must be preceded by a distinct intonation break and bear accent.

- (125) a. dat Jan ons waarschijnlijk zal vertellen [dat hij zal aftreden].  
 that Jan us probably will tell that he will prt.-resign  
 ‘that Jan will probably tell us that is going to resign.’  
 b. #dat Jan ons zal vertellen dat hij zal aftreden waarschijnlijk.  
 b’. dat Jan ons zal vertellen waarschijnlijk [dat hij zal aftreden].

The same probably holds for example (126b), although the more prominent interpretation is that the adverb *morgen* ‘tomorrow’ is construed with the object clause as a backgrounded right-dislocated phrase: it is not the telling but the resignation that will take place tomorrow.

- (126) a. dat Jan ons morgen zal vertellen [dat hij zal aftreden].  
 that Jan us tomorrow will tell that he will prt.-resign  
 ‘that Jan will tell us tomorrow that he’ll resign.’  
 b. #dat Jan ons zal vertellen dat hij zal aftreden morgen.  
 b’. dat Jan ons zal vertellen morgen [dat hij zal aftreden].

It should be noted however that Section 12.3 has shown that postverbal adverbs like *waarschijnlijk* and *morgen* are also right-dislocated. If correct, we have to conclude that the object clauses in the primed (b)-examples in (125) and (126) are not extraposed, but left-dislocated as well. This seems to be confirmed by the fact that VP-topicalization cannot pied pipe the object clause if the adverb is present.



- (127) a. [Vertellen (\*waarschijnlijk) dat hij zal aftreden] zal Jan ons morgen.  
 tell probably that he will prt.-resign will Jan us tomorrow  
 b. [Vertellen (\*morgen) dat hij zal aftreden] zal Jan ons niet.  
 tell tomorrow that he will prt.-resign will Jan us not

This, in turn, makes it plausible that the doubly-primed examples in (124) also involve right dislocation and should therefore be ignored for our present purposes. The discussion above shows that determining the relative order of extraposed phrases is not a trivial matter, and should receive much more attention than it has been given so far.

## II. Prepositional objects

Prepositional objects are normally adjacent to the clause-final verb(s), regardless of whether they precede or follow these verb(s). This can be seen as an immediate consequence of the mirror effect; elements that are left-adjacent to the clause-final verbs in the middle field of the clause are expected to be right-adjacent to these verb(s) when extraposed. Subsection IA has already illustrated this for the order of postverbal prepositional objects and argument clauses. The examples in (128) show that the mirror effect also occurs in the case of adverbial clauses/PPs.

- (128) a. Jan heeft [voordat hij vertrok] toch nog [naar de post] gekeken.  
 Jan has before he left yet still at the post looked  
 'Before he left, Jan had looked at the mail after all.'  
 a'. Jan heeft toch nog gekeken [naar de post] [voordat hij vertrok].  
 a''. \*Jan heeft toch nog gekeken [voordat hij vertrok] [naar de post].  
 b. Jan heeft [voor zijn vertrek] toch nog [naar de post] gekeken.  
 Jan has before his departure yet still at the post looked  
 'Before his departure, Jan had looked at the mail after all.'  
 b'. Jan heeft toch nog gekeken [naar de post] [voor zijn vertrek].  
 b''. \*Jan heeft toch nog gekeken [voor zijn vertrek] [naar de post].

It should be noted that prepositional object clauses differ from postverbal PP-objects in that they tend to follow postverbal adverbial phrase; an example like (129b') is only acceptable with the intonation contour associated with afterthoughts, that is, with a distinct intonation break before the adverbial phrase, which also receives contrastive accent. This is of course not surprising in view of our conclusion in Section 12.2, sub IB, that clauses introduced by an anticipatory pronominal element are not extraposed but right-dislocated.

- (129) a. dat Jan er [in het buitenland] al snel naar verlangt  
 that Jan there in the foreign.countries already quickly for longs  
 [dat hij naar huis kan].  
 that he to home can  
 'that when abroad, Jan soon wants to go home again.'  
 b. dat Jan er al snel naar verlangt [in het buitenland] [dat hij naar huis kan].  
 b'. dat Jan er al snel naar verlangt [dat hij naar huis kan] \*(,) [in het buitenland].

That prepositional object clauses introduced by an anticipatory PP are not extraposed but right-dislocated is also clear from the fact illustrated in (130) that they obligatorily follow postverbal adjectival and nominal adverbial phrases like *waarschijnlijk* ‘probably’ and *morgen* ‘tomorrow’, which were shown to be right-dislocated in Section 12.3.

- (130) a. dat Jan erop wacht waarschijnlijk [dat het bericht vrij komt].  
 that Jan for.it waits probably that the news free comes  
 ‘that Jan is probably waiting for the release of the news.’  
 b. dat Jan erop zal wachten morgen [dat het bericht vrij komt].  
 that Jan for.it will wait tomorrow that the news free comes  
 ‘that Jan will wait tomorrow for the release of the news.’

### III. Adverbial phrases

This section discusses the relative order of adverbial phrases. Example (131b) shows that it is at least marginally possible for a temporal and a locational PP to co-occur in the postverbal field. The examples in (131) further show that we find the mirror effect here—while the temporal adverbial phrase preferably precedes the locational adverbial phrase in the middle field of the clause, it preferably follows it in the postverbal field.

- (131) a. Jan heeft waarschijnlijk [tot drie uur] [in de tuin] gewerkt.  
 Jan has probably until 3 o'clock in the garden worked  
 ‘Jan has probably worked in the garden until 3 o'clock.’  
 a'. \*Jan heeft waarschijnlijk [in de tuin] [tot drie uur] gewerkt.  
 b. <sup>(?)</sup>Jan heeft waarschijnlijk gewerkt [in de tuin] [tot drie uur].  
 b'. <sup>??</sup>Jan heeft waarschijnlijk gewerkt [tot drie uur] [in de tuin].

In (132) we provide similar examples involving the adverbial phrase *ondanks de hitte* ‘despite the heat’ and a locational adverbial phrase: while the former must precede the locational adverbial phrase in the middle field of the clause (under a neutral intonation pattern), it follows it in the postverbal field.

- (132) a. Jan heeft [ondanks de hitte] [in de tuin] gewerkt.  
 Jan has despite the heat in the garden worked  
 ‘Jan has worked in the garden despite the heat.’  
 a'. \*Jan heeft [in de tuin] [ondanks de hitte] gewerkt.  
 b. <sup>(?)</sup>Jan heeft gewerkt [in de tuin] [ondanks de hitte].  
 b'. \*Jan heeft gewerkt [ondanks de hitte] [in de tuin].

Note in passing that the linear string in (132b') is acceptable under the irrelevant reading in which the PP *in de tuin* ‘in the garden’ modifies the noun *hitte* ‘heat’, as in (133a); this example differs from (132a) in meaning and intonation.

- (133) a. Jan heeft [ondanks de hitte [in de tuin]] gewerkt.  
 Jan has in.spite.of the heat in the garden worked  
 ‘Jan has worked in spite of the heat in the garden.’  
 b. Jan heeft gewerkt [ondanks de hitte [in de tuin]].

#### IV. Conclusion

This subsection has discussed a number of restrictions on word order in the postverbal field. We have seen that PP-complements precede direct object clauses while adverbial clauses come last. This order is the inverse of the order found in the middle field of the clause, which has motivated the postulation of a mirror effect: extraposition inverts the order. Note in passing that the order in (134) is identical to the one found in English.

(134) ... V<sub>final</sub> – PP-complement – object clause – adverbial clause

Prepositional adverbial phrases at first seem to exhibit a somewhat deviant behavior to the extent that they may precede object clauses. We have seen, however, that this may be due to the fact that object clauses need not be extraposed but can also be right-dislocated, which can be supported by the fact illustrated again in (135) that object clauses may also follow postverbal adverbial phrases like *waarschijnlijk* ‘probably’ and *gisteren* ‘yesterday’, which were argued to be right-dislocated in Section 12.3

- (135) a. dat Jan vertelde aan Marie gisteren dat hij zou komen.  
 that Jan told to Marie yesterday that he would come  
 ‘that Jan told Marie yesterday that he would come.’  
 b. dat Jan zei tegen Peter vanmorgen dat hij zou komen.  
 that Jan said to Peter this.morning that he would come  
 ‘that Jan said to Peter this morning that he would come.’

This mirror effect was first observed by Koster (1974) for PPs and it is often tacitly assumed that it is restricted to phrases of this type; see Barbiers (1995:ch.4) for an interesting analysis based on this assumption. The examples given in this section show, however, that the effect is also found with clauses.

#### 12.6. Bibliographical notes

The early versions of generative grammar normally assumed that phrases occupying the postverbal field are base-generated in the middle field of the clause, in line with Koster’s hypothesis that the underlying structure of Dutch is OV in nature, and are subsequently moved into postverbal position by a rule known as EXTRAPOSITION in the case of clauses and PP-OVER-V in the case of PPs; we simply refer to this rule as extraposition. A problem for this proposal was that it is not in line with Emonds’ (1976) STRUCTURE PRESERVATION PRINCIPLE, which requires movement to target an independently motivated position; cf. Emonds (1976).

If this was not enough, extraposition also came up against an important empirical problem related to the °freezing principle, which prohibits *wh*-extraction from a moved phrase. At first sight, extraposition of PPs seems to provide strong evidence in favor of a movement analysis, as it only allows *wh*-extraction if the PP is in preverbal position; if the postverbal position of the PP in (136b) is indeed a derived position, the freezing principle correctly predicts *wh*-extraction from that position to be impossible.

- (136) a. Jan heeft dagen <op het pakketje> gewacht < op het pakketje>.  
 Jan has days for the parcel waited  
 ‘Jan has been waiting for the parcel for days.’  
 b. Waar heeft Jan dagen <[op  $t_i$  ]> gewacht <\*[op  $t_i$  ]>?  
 where has Jan days for waited  
 ‘What has Jan been waiting for for days.’

However, this principle also predicts that *wh*-extraction from an extraposed clause is impossible, but this is clearly wrong given that it is possible in so-called ‘bridge-verb contexts; cf. De Haan (1979).

- (137) a. Marie zei [dat Jan haar boek gekocht had].  
 Marie said that Jan her book bought had  
 ‘Marie said that Jan had bought her book.’  
 b. Welk boek zei Marie [dat Jan  $t_i$  gekocht had]?  
 which book said Marie that Jan bought had  
 ‘Which book did Marie say that Jan had bought?’

The contrast between the extraction possibilities from extraposed PPs and clauses has given rise to the claim that extraposition is not a unitary phenomenon. Barbiers (1995/2000), for example, provides two completely different but compatible analyses for the examples in (136) and (137). That extraposition is not a unitary phenomenon becomes even clearer when we include split extraposition, which has resisted a satisfactory syntactic account for a very long time. Since Kaan (1992), analyses have been developed that give up the idea that split extraposition is derived from a structure in which the split parts form a constituent underlyingly. Koster (2000) and De Vries (1999/2002) have claimed that split extraposition is actually a form of juxtaposition (with or without deletion). For more historical background we refer the reader to Section 9.4, as well as Corver (1991), Kaan (1992), Koster (2000), Baltin (2006), De Vries (2002), and references cited there.

# Chapter 13 Word order in the clause V: Middle field (scrambling)

<b>Introduction</b>	<b>1596</b>
<b>13.1. Unmarked word orders in the middle field of the clause</b>	<b>1599</b>
<b>13.2. A-Scrambling: nominal argument shift</b>	<b>1608</b>
<b>13.3. A'-scrambling: negation, focus and topic movement</b>	<b>1625</b>
<i>13.3.1. Negation movement</i>	<i>1627</i>
<i>13.3.2. Contrastive focus and topic movement</i>	<i>1637</i>
<i>13.3.3. Conclusion</i>	<i>1660</i>
<b>13.4. Weak proform shift</b>	<b>1661</b>
<b>13.5. Bibliographical notes</b>	<b>1677</b>

**Introduction**

This chapter takes as its point of departure the discussion in Section 9.2, which has shown that finite verbs can be found in basically two positions: the clause-final position in embedded clauses and the verb-first/second position in main clauses; the latter position is normally occupied by a complementizer in embedded clauses.

- (1) a. Marie zegt [dat Jan het boek *leest*].  
 Marie says that Jan the book reads  
 ‘Marie says that Jan is reading the book.’
- b. Op dit moment *leest* Jan het boek.  
 at this moment reads Jan the book  
 ‘At this moment, Jan is reading the book.’

On the basis of these two positions, the clause is traditionally divided into various “topological” fields: the clause-initial position, the middle field and the postverbal field. This is illustrated in Figure (2), repeated from Section 9.2.

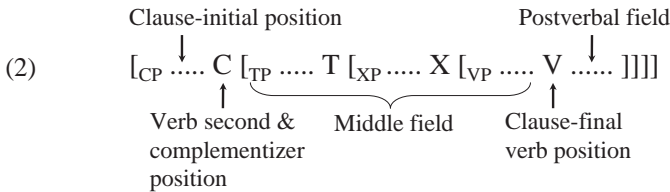

This chapter will focus on the middle field of the clause. Section 9.1 has shown, however, that this notion has no independent theoretical status as it cuts across the more fundamental division between the lexical and the functional domain of the clause.

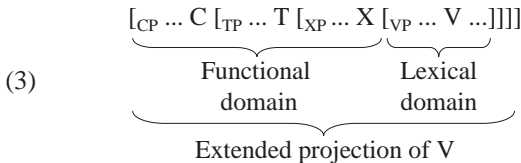

The LEXICAL DOMAIN consists of the main verb and its arguments as well as VP modifiers, which together form a proposition. In (4a), for example, the verb *kopen* ‘to buy’ takes a direct object as its complement and is subsequently modified by the manner adverb *snel* ‘quickly’, and the resulting complex predicate is finally predicated of the noun phrase *Jan*. The complex phrase thus formed expresses the proposition that can be represented by means of the logical formula in (4b).

- (4) a. [Jan [snel [het boek kopen]]]  
 Jan quickly the book buy
- b. BUY QUICKLY (Jan, the book)

If the proposition in (4b) is to correspond to the syntactic structure in (4a), we should assume that the VP in (3) must be replaced by a more finely articulated syntactic structure. In current generative research it is generally assumed that this structure is as given in (5). As the linking of semantic and syntactic structure is

unlikely to vary across languages, it is often assumed that the structure in (5) is more or less invariant across languages, and that the surface differences between languages are due to movement. For example, the word order difference between Dutch and English with respect to the relative placement of the verb and the nominal direct object can be accounted for by assuming that English but not Dutch has obligatory V-to-v movement; see Section 9.4 for a more detailed discussion.

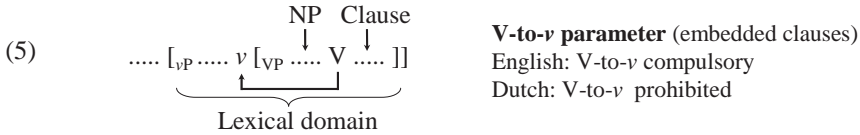

The structure in (4a) can now be made more explicit as in (6): internal arguments such as the theme *het boek* ‘the book’ are generated within VP, VP adverbials such as the manner adverb *snel* ‘quickly’ are adjoined to VP, and external arguments such as the agent *Jan* are generated as the specifier of the “light” verb *v*.

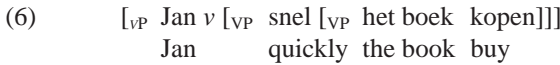

In what follows we will adopt the assumption that the lexical domain does have a more finely articulated structure, and we therefore replace the global representation of the clause in structure (3) by the one in (7). Observe that the lexical domain may be even more complex than indicated here, as we have ignored issues raised by structures with, e.g., indirect objects or °complementives.

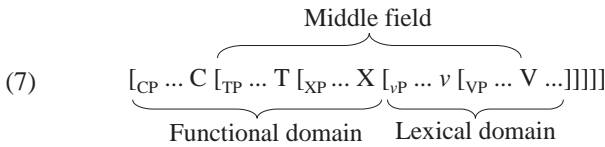

The semantic information encoded in the lexical domain can be equated with the information expressed by traditional predicate calculus; the FUNCTIONAL DOMAIN provides additional information. For instance, the functional head T in (7) adds the tense feature [ $\pm$ PAST] and the functional head C indicates illocutionary force, as is clear from the fact that the complementizers *dat* ‘that’ and *of* ‘if/whether’ introduce embedded declarative and interrogative clauses, respectively. In addition to these functional heads there may be other functional heads, indicated by X in (7), which introduce other features. Section 10.1 has shown that in main clauses finite verbs are moved out of the lexical domain into the functional head C (or T), which accounts for the verb-first/second effect in Dutch.

Although arguments, complementives and VP adverbials generally surface within the lexical domain, they can also be moved into the functional domain. Normally, this has a semantic motivation; Section 11.3.1 has shown, for instance, that *wh*-phrases are moved into clause-initial position in order to create structures such as (8a), which can be translated more or less directly into the logical formula in (8b): the interrogative pronoun *wat* in clause-initial position corresponds to the question operator ?*x*, while the °trace of the *wh*-phrase corresponds to the variable *x*.



- (8) a. Wat<sub>i</sub> leest Peter t<sub>i</sub>?  
 what reads Peter  
 ‘What is Peter reading?’  
 b. ?x (Peter is reading x)

The effect of *wh*-movement is immediately clear in main clauses from the fact that the *wh*-phrase surfaces in the position preceding the finite verb. Movements targeting a clause-internal position are often less easy to observe. For instance, it is normally assumed that in passive constructions the internal theme argument moves from its original VP-internal position into the regular subject position, that is, the specifier position of TP in (7), but this can only be observed if other material is present between the two positions. This is illustrated by the passive example in (9b), which shows that the postulated movement is indeed possible in Dutch but optional if the derived subject is definite. Whether or not the movement applies is of course less easy to determine if the indirect object is left implicit as the effect of movement cannot be observed directly from the word order of the clause in that case.

- (9) a. dat de gemeente (de koning) het concert aanbood. [active]  
 that the municipality the king the concert prt-offered  
 ‘that the municipality offered the king the concert.’  
 b. dat <het concert> (de koning) <het concert> aangeboden werd. [passive]  
 that the concert the king prt-offered was  
 ‘that the concert was offered to the king.’

In order to investigate whether some element has moved from the lexical into the functional domain we appear to need a demarcation of the boundary between the two domains; compare the notion of pivot location in Haeseryn et al. (1997:1328) and the notion of comment modifier in Verhagen (1986:ch.4). Clausal adverbs such as the modal *waarschijnlijk* ‘probably’ can perform this function because they take scope over the full proposition expressed by the *vP* in (7). This fact is actually exploited by the standard °adverb tests according to which clausal adverbs can be paraphrased by means of the construction *Het is ADVERB zo dat ...* ‘it is adverb so that ...’, in which the adverb likewise has scope over the proposition expressed by the embedded clause.

- (10) a. Jan werkt waarschijnlijk.  
 Jan works probably  
 ‘Jan is probably working.’  
 b. Het is waarschijnlijk zo dat Jan werkt.  
 it is probably the.case that Jan works  
 ‘It is probably the case that Jan is working.’

Another argument in favor of assuming that modal adverbs demarcate the boundary between the lexical and the functional domain is the fact illustrated in (11) that they can precede an external argument, which is located at the left edge of the lexical domain, namely in the specifier of the light verb *v* in (5)/(7).

- (11) dat [<sub>TP</sub> <de klant> waarschijnlijk [<sub>VP</sub> <de klant> v [<sub>VP</sub> het boek koopt]]].  
 that the customer probably the book buys  
 ‘that the customer will probably buy the book.’

Example (11) shows that the movement of the subject into the regular subject position is not only optional in passive constructions such as (9b) but also in active constructions. We return to this fact in Section 13.2, where it will be shown that the movements indicated in (12), which we will refer to as SUBJECT SHIFT because they affect a noun phrase that surfaces as the nominative subject, are restricted by the information structure of the clause; they apply only if the subject provides discourse-old information.

- (12) a. [<sub>CP</sub> ... C [<sub>TP</sub> ... T [<sub>XP</sub> ... X Adverb [<sub>VP</sub> Subject v [<sub>VP</sub> Object V ...]]]]]  
 ↑ Subject shift in active voice
- b. [<sub>CP</sub> ... C [<sub>TP</sub> ... T [<sub>XP</sub> ... X Adverb [<sub>VP</sub> ... v [<sub>VP</sub> Subject V ...]]]]]  
 ↑ Subject shift in passive voice

That subjects raise into the regular subject position has been a standard claim in generative grammar for a very long time (especially for passive constructions). This chapter discusses a number of other movement operations that likewise move elements out of the lexical domain into the functional domain in as far as this results in reordering of the constituents in *the middle field of the clause*: the various forms of *wh*-movement, which place elements into *clause-initial* position, are not discussed here but in Section 11.3. Following Ross (1967), the reordering of the middle field is often referred to as SCRAMBLING but there are reasons not to follow this practice because it incorrectly suggests that we are dealing with a single, uniform phenomenon. We will show that scrambling is in fact a pre-theoretical cover term for a wider set of movement phenomena with diverging properties. Section 13.2 will discuss nominal argument shift, which was referred to as NP-preposing in earlier generative literature, for instance Van den Berg (1978) and De Haan (1979); this movement type affects nominal arguments only and plays an important role in distinguishing between the presupposition and the focus of the clause, that is, between discourse-old and discourse-new information; see the discussion of (9) and (11) above. Section 13.3 will show that negative and contrastive phrases can likewise be moved into a more leftward position; this movement is not restricted to nominal arguments but can also be applied to specific constituents of other categories. Section 13.4 concludes by showing that phonologically weak forms like the referential personal pronoun *'m* ‘him’ and the locational proform *er* ‘there’ are obligatorily moved into a position close to the regular subject position of the clause. Section 13.1 starts by introducing the notion UNMARKED WORD ORDER, however.

### 13.1. Unmarked word orders in the middle field of the clause

This section discusses unmarked word orders in the middle field of the clause. It will not be immediately obvious what the denotation of the notion UNMARKED is: this section will informally characterize it by means of a brief discussion of some semantic, syntactic and phonological properties of clauses. Semantically, unmarked word orders are understood in terms of information structure, especially the division

of the clause in discourse-old and discourse-new information. Syntactically, unmarked word orders are understood in terms of the base order of constituents, and phonologically they are characterized by exhibiting a non-contrastive intonation contour. In short, we will assume that constituents appear in the unmarked order if they are part of the new information °focus of their clause, observe certain linearization restrictions, and are not contrastively accented.

### *I. New-information focus*

The literature often investigates unmarked orders by means of answers to *wh*-questions in the onset of a discourse. The reason is that in this context the part of the answer corresponding to the *wh*-word belongs to the new-information focus of its clause and is normally not contrastively marked. For example, the full answer to opening question (13a) given in (13b) provides discourse-new information, and it would therefore be unexpected if one of the clausal constituents were contrastively marked.

- (13) a. Wat is er aan de hand? [question]  
 what is there to the hand  
 ‘What is going on?’  
 b. Jan heeft de boeken aan Marie aangeboden. [answer]  
 Jan has the books to Marie prt.-offered  
 ‘Jan has offered the books to Marie.’

That the full clause in (13b) is part of the new-information focus is also clear from the fact that (without additional extra-linguistic information) pronominalization of the noun phrases is impossible. This is different in answers to opening questions that introduce a discourse topic, such as (14a&b); in the answers in the primed examples everything is part of the discourse-new information apart from the topics introduced by the corresponding questions, as is clear from the fact that the latter are the only constituents that can be pronominalized in these contexts.

- (14) a. Wat heeft Jan gedaan? [question]  
 what has Jan done  
 ‘What has Jan done?’  
 a'. Jan/Hij heeft de boeken aan Marie aangeboden. [answer]  
 Jan/he has the books to Marie prt.-offered  
 ‘Jan/He has offered the books to Marie.’  
 b. Wat is er met de boeken gebeurd? [question]  
 what is there with the books happened  
 ‘What has happened to the books?’  
 b'. Jan heeft de boeken/ze aan Marie aangeboden. [answer]  
 Jan has the books/them to Marie prt.-offered  
 ‘Jan has offered the books/them to Marie.’

Observe that the notion DISCOURSE-NEW does not imply that the hearer is unable to identify the intended entities, because in that case the answers in (13) and (14) would make no sense; the hearer can be assumed to be able to identify the intended referents of the noun phrases, and the new-information focus of the clause merely activates these entities as relevant for the ongoing discourse.

## II. The unmarked order of arguments and complementives

We can investigate the unmarked order of nominal arguments in the middle field of the clause by considering possible answers to the opening question *Wat is er gisteren gebeurd?* ‘What happened yesterday?’. Answer (15a) shows that subjects precede direct objects: inverting the two arguments results in a severely degraded result. Answer (15b) shows that nominal indirect objects precede direct objects.

- (15) a. Gisteren heeft Jan<sub>Subject</sub> de boeken<sub>DO</sub> gekocht.  
 yesterday has Jan the books bought  
 ‘Yesterday Jan bought the books.’  
 b. Gisteren heeft Jan<sub>Subject</sub> Marie<sub>IO</sub> de boeken<sub>DO</sub> aangeboden.  
 yesterday has Jan Marie the books prt.-offered  
 ‘Yesterday Jan offered Marie the books.’

The question now arises as to whether the word order generalization that presents itself should be expressed by appealing to the grammatical functions of nominal arguments, as in (16a), or by appealing to their °semantic roles, as in (16b).

- (16) a. grammatical function: subject > indirect object > direct object  
 b. thematic role: agent > goal > theme

The passive counterpart of example (15b) in (17) suggests that the latter is to be preferred as the indirect object precedes the derived (theme) subject; the reversed order in *Gisteren werden de boeken (door Jan) Marie aangeboden* is of course grammatical but infelicitous as an answer to the opening question *Wat is er gisteren gebeurd?* ‘What happened yesterday?’.

- (17) Gisteren werden (door Jan) Marie<sub>IO</sub> de boeken<sub>Subject</sub> aangeboden.  
 yesterday were by Jan Marie the books prt.-offered  
 ‘Yesterday the books were offered to Marie (by Jan).’

Example (18a) shows that the order of the indirect and the direct object must be inverted if the former is realized as a PP: the direct object precedes the prepositional indirect object. In fact, it seems a quite robust generalization that nominal objects precede prepositional objects in the unmarked order; cf. De Haan (1979). This is illustrated for a direct object in (18b) and a nominal indirect object in (18b’); we refer the reader to Sections 2.3.2, sub I, and 2.3.3 for a discussion of these two types of prepositional object construction.

- (18) a. Gisteren heeft Jan<sub>Subject</sub> het boek<sub>DO</sub> aan Marie<sub>IO</sub> aangeboden.  
 yesterday has Jan the book to Marie prt.-offered  
 ‘Yesterday Jan offered the book to Marie.’  
 b. Gisteren heeft de directeur Peter<sub>DO</sub> met de opdracht belast.  
 yesterday has the manager Peter with the assignment charged  
 ‘Yesterday the manager made Peter responsible for the assignment.’  
 b’. Gisteren heeft Marie Peter<sub>IO</sub> over het probleem verteld.  
 yesterday has Marie Peter about the problem told  
 ‘Yesterday Marie told Peter about the problem.’

The examples in (19) show that nominal arguments also precede complementives (including verbal particles), which is not surprising given that Section 2.2 already noticed that these are typically positioned left-adjacent to the clause-final verbs.

- (19) a. Marie heeft het hek donkerblauw geschilderd. [adjectival complementive]  
 Marie has the gate deep.blue painted  
 ‘Marie has painted the gate deep blue.’
- b. Jan heeft de vaas in stukken gegoooid. [prepositional complementive]  
 Jan has the vase in pieces thrown  
 ‘Jan has smashed the vase to pieces.’
- c. Jan heeft de vaas weggegoooid. [verbal particle]  
 Jan has the vase away.thrown  
 ‘Jan has thrown away the vase.’

The discussion above has demonstrated that arguments and complementives exhibit a clear unmarked order; the word order generalizations we have established are given in (20).

- (20) • Unmarked order of arguments and complementives
- a. nominal arguments: agent > goal > theme
  - b. nominal objects > prepositional objects
  - c. nominal objects > complementives

We will adopt as a working hypothesis that the generalizations in (20) reflect the relative orders of these clausal constituents within the lexical domain of the clause (which is in fact not easy to establish). This means that marked orders result from movement operations that move these constituents into certain positions in the functional domain of the clause. Furthermore, we will assume that these movements are motivated by specific syntactic, semantic and/or phonological considerations.

### *III. Sentence accent*

The distinction between unmarked and marked word orders is often reflected in the intonation contour of clauses. For our present purpose, we confine ourselves to the location of the so-called sentence accent in main clauses with at least one object and a verb in clause-final position. We will start by discussing the default placement of sentence accent that can be found in neutral clauses. After that we will briefly discuss the semantic effects of alternative placements of accents.

#### *A. Neutral intonation: the location of sentence accent*

Main clauses with an object and a verb in clause-final position may have various accents. We take the sentence accent to be located at the end of the clause and to involve a sudden pitch lowering, which means that we adopt a more restrictive definition of sentence accent than some of the references given below. It seems relatively uncontroversial that the sentence accent (in our sense) is normally located within the lexical domain of the clause in some phrase preceding the clause-final main verb; see Baart (1987), Gussenhoven (1992), Booij (1995), and references given there. This observation has found a syntactic explanation in Cinque’s (1993) hypothesis that stress prominence is a reflection of depth of embedding: the default

location of the sentence accent is the most deeply embedded constituent that may carry a word accent in the syntactic surface structure of the clause or, as a possibly better alternative, a prosodic structure derived from it by the elimination of phonetically empty nodes, as proposed by Baart (1987). This means that the sentence accent must be placed on the object provided that the latter is located within the lexical domain. The examples in (21) show that the proviso is indeed needed given that leftward movement of the object into the functional domain results in deaccenting the object; cf. Verhagen (1986). Note that sentence accent is indicated by small caps.

- (21) a. Jan heeft waarschijnlijk<sub>VP</sub> [<sub>NP</sub> mijn ZUster] bezocht].  
 Jan has probably my sister visited  
 ‘Jan has probably visited my sister.’  
 b. Jan heeft mijn zuster<sub>i</sub> waarschijnlijk [<sub>VP</sub> t<sub>i</sub> bezOCHT].  
 Jan has my sister probably visited  
 ‘Jan has probably visited my sister.’

We can illustrate the same on the basis of the examples in (22) with the help of the particle verb *uitnodigen* ‘to invite’; we adopt the hypothesis in Section 2.2 that the object and the verbal particle constitute a °small clause. The default placement of sentence accent in (22a) is on the noun *zuster*, because this is again the most deeply embedded element with word/phrase accent. Example (22b) shows that nominal argument shift of the object into a position external to the lexical domain causes the sentence accent to shift onto the particle, as this particle is now the most deeply embedded constituent in the resulting structure.

- (22) a. Jan heeft waarschijnlijk [<sub>VP</sub> [<sub>SC</sub> [<sub>NP</sub> mijn ZUster] uit] genodigd].  
 Jan has probably my sister prt. invited  
 ‘Jan has probably invited my sister.’  
 b. Jan heeft mijn zuster<sub>i</sub> waarschijnlijk [<sub>VP</sub> [<sub>SC</sub> t<sub>i</sub> UIT] genodigd].  
 Jan has my sister probably prt called  
 ‘Jan has probably invited my sister.’

Additional support for Cinque’s hypothesis that the default placement of the sentence accent is on the most deeply embedded constituent in the clause is provided in (23): example (23a) shows that the sentence accent is realized on the most deeply embedded phrase within the object, and (23b) shows that sentence accent must be realized on the complementive if it is complex, as the nominal complement of the preposition phrase *in de vaas* is more deeply embedded than the subject of the small clause, *bloemen* ‘flowers’.

- (23) a. Jan heeft waarschijnlijk [<sub>VP</sub> [<sub>NP</sub> het meisje [uit [HAARlem]]] ontmoet].  
 Jan has probably the girl from Haarlem met  
 ‘Jan has probably met the girl from Haarlem.’  
 b. Jan heeft waarschijnlijk [<sub>VP</sub> [<sub>SC</sub> bloemen [in [de VAAS]]] gezet].  
 Jan has probably flowers into the vase put  
 ‘Jan has probably put flowers in the vase.’

A final piece of evidence in favor of Cinque's hypothesis is given in (24), which shows that the location of sentence accent depends on the syntactic function of the phrase preceding the verb. The PP in (24a) functions as a prepositional object and this correctly predicts that the default placement of sentence accent is on the nominal complement of the PP as this is the most deeply embedded phrase. Since the PP in (24b) functions as an adverbial phrase, it must be external to the VP and this correctly predicts that the sentence accent is realized on the participle. Since the complementive PP in (24c) is again part of the VP, it is again correctly predicted that the sentence accent is realized on the nominal complement of the PP; see also Gussenhoven (1992).

- (24) a. Jan heeft [<sub>VP</sub> [<sub>PP</sub> op [zijn vader]] gewacht]. [prepositional object]  
 Jan has for his father waited  
 'Jan has waited for his father.'
- b. Jan heeft [<sub>PP</sub> op het perron] [<sub>VP</sub> gewacht]. [adverbial PP]  
 Jan has on the platform waited  
 'Jan has waited on the platform.'
- c. Jan<sub>i</sub> is [<sub>VP</sub> [<sub>SC</sub> t<sub>i</sub> op het perron] gebleven]. [complementive PP]  
 Jan is on the platform stayed  
 'Jan has stayed on the platform.'

### B. Information-structural effects of non-neutral intonation patterns

The previous subsection has described Cinque's rule that derives neutral intonation patterns: the sentence accent is assigned to the most deeply embedded phrase within the lexical domain that may carry a word accent, which is prototypically an object. Clauses with a neutral intonation pattern are often ambiguous with respect to the focus-presupposition division: new-information focus can be restricted to the clausal constituent to which sentence accent is assigned, but it can also extend to include larger projections of the clause containing it. In the examples in (25), for instance, the new-information focus can be restricted to the direct object, but it can also be extended to include the (particle) verb; that this extension is possible is clear from the fact that these sentences can be used as answers to the question *Wat heeft Jan gedaan?* 'What has Jan done?'. The alternative options in (25) thus differ in the scope of new-information focus, which is indicated by underlining.

- (25) a. Jan heeft waarschijnlijk [<sub>VP</sub> [<sub>NP</sub> mijn Zuster] bezocht].  
 Jan has probably my sister visited  
 'Jan has probably visited my sister.'
- a'. Jan heeft waarschijnlijk [<sub>VP</sub> [<sub>NP</sub> mijn Zuster] bezocht].  
 Jan has probably my sister visited
- b. Jan heeft waarschijnlijk [<sub>VP</sub> [<sub>SC</sub> [<sub>NP</sub> mijn Zuster] uit] genodigd].  
 Jan has probably my sister prt. invited  
 'Jan has probably invited my sister.'
- b'. Jan heeft waarschijnlijk [<sub>VP</sub> [<sub>SC</sub> [<sub>NP</sub> mijn Zuster] uit] genodigd].  
 Jan has probably my sister prt. invited



Clauses that deviate from the prototypical assignment of the sentence accent can arise in two different ways, both of which have repercussions for the information structure of the clause. First, the element that would normally be assigned sentence accent can be removed from the lexical domain of the clause, as a result of which the sentence accent will be assigned in accordance with Cinque's rule to the next most deeply embedded element. The examples in (26) show that the information-structural effect of leftward movement of the objects in (25) is that the objects can no longer be construed as part of the new-information focus but must be construed as part of the presupposition of the clause. Section 13.2 will discuss this in more detail.

- (26) a. Jan heeft mijn zuster<sub>i</sub> waarschijnlijk [<sub>VP</sub> *t<sub>i</sub>* beZOCHT].  
 Jan has my sister probably visited  
 b. Jan heeft mijn zuster<sub>i</sub> waarschijnlijk [<sub>VP</sub> [<sub>SC</sub> *t<sub>i</sub>* UIT] genodigd].  
 Jan has my sister probably prt. invited

Another way of deriving non-neutral intonation patterns, which will be discussed more extensively in Section 13.3, is by simply ignoring Cinque's rule. The examples in (27) show that this again results in a more restricted focus domain. The primeless examples in (27) have a neutral intonation pattern with the sentence accent on the most deeply embedded phrase and they can be interpreted such that all phrases within the lexical domain (VP) are part of new-information focus of the clause. The primed examples, on the other hand, have a marked main accent on a phrase higher in the structure and this triggers a so-called CONTRASTIVE reading: the contrastively accented phrase (indicated by italics) is taken to be the relevant discourse-new information while the remainder of the lexical domain is construed as (familiar) background information. A contrastive intonation pattern is often used to correct information given earlier in the discourse or to exclude alternative possibilities, which we have indicated in the translations of these examples by adding the part within parentheses.

- (27) a. Jan heeft waarschijnlijk [<sub>VP</sub> [het meisje] [[dat BOEK] gegeven]].  
 Jan has probably the girl that book given  
 'Jan has probably given the girl that book.'  
 a'. Jan heeft waarschijnlijk [<sub>VP</sub> [het MEISje] [[dat boek] gegeven]].  
 Jan has probably the girl that book given  
 'Jan has probably given the girl that book (not the boy).'  
 b. Jan heeft waarschijnlijk [<sub>VP</sub> [dat boek] [[aan [het MEISje] gegeven]].  
 Jan has probably that book to the girl given  
 'Jan has probably given that book to the girl.'  
 b'. Jan heeft waarschijnlijk [<sub>VP</sub> [dat BOEK] [[aan [het meisje] gegeven]].  
 Jan has probably that book to the girl given  
 'Jan has probably given that book to the girl (and not, e.g., the record).'

The same can be observed in examples such as (28): the sentence accent in the primeless examples is assigned to the most deeply embedded phrase within the lexical domain, and this allows an interpretation according to which the full lexical domain is part of the new-information focus of the clause. Shifting the accent to

some other element within the noun phrase/small clause, as in the primed examples, again results in a more restricted contrastive focus reading; see Booij (1995:159) and Cinque (1993: section 6) among many others.

- (28) a. Jan heeft waarschijnlijk [<sub>VP</sub> [<sub>NP</sub> het meisje [uit [HAARlem]]] ontmoet].  
 Jan has probably the girl from Haarlem met  
 'Jan has probably met the girl from Haarlem.'
- a'. Jan heeft waarschijnlijk [<sub>VP</sub> [<sub>NP</sub> het MEISje [uit [Haarlem]]] ontmoet].  
 Jan has probably the girl from Haarlem met  
 'Jan has probably met the girl from Haarlem (not the boy).'
- b. Jan heeft waarschijnlijk [<sub>VP</sub> [<sub>SC</sub> bloemen [in [de VAAS]]] gezet].  
 Jan has probably flowers into the vase put  
 'Jan has probably put flowers in the vase.'
- b'. Jan heeft waarschijnlijk [<sub>VP</sub> [<sub>SC</sub> BLOEmen [in [de vaas]]] gezet].  
 Jan has probably flowers into the vase put  
 'Jan has probably put flowers in the vase (not peacock feathers).'

Observe that we used different typographical means for indicating the accents in (27) and (28): regular small caps for default sentence accent and small caps in italics for contrastive accent. The reason is that the two accents are not identical, as is clear from the fact that contrastive accent can also be assigned to phrases that would normally be assigned default sentence accent. The result of using contrastive accent instead of the regular sentence accent is again that the new-information focus is narrowed: while the verb may be part of the discourse-new information under a neutral intonation pattern, as in (29a), this is not the possible if contrastive accent is used, as in (29b). The two accents in (29) differ phonologically in that contrastive accent has an additional high tone.

- (29) a. Jan heeft waarschijnlijk [<sub>VP</sub> [het MEISje] uit] genodigd].  
 Jan has probably the girl prt. invited  
 'Jan has probably invited the girl.'
- b. Jan heeft waarschijnlijk [[het MEISje] uit] genodigd].  
 Jan has probably the girl prt. invited  
 'Jan has probably invited the girl (and not, e.g., the boy).'

Finally, it should be noted that contrastively accented phrases are often displaced: the examples in (30) show that the unmarked order of the direct and prepositional indirect object can optionally be reversed if the latter is assigned contrastive accent. This will be the main topic of Section 13.3.

- (30) a. Jan heeft het boek aan MARIE/MARIE aangeboden.  
 Jan has the book to Marie prt.-offered  
 'Jan has offered the book to Marie.'
- b. Jan heeft aan MARIE/\*MARIE het boek aangeboden.  
 Jan has to Marie the book prt.-offered  
 'Jan has offered the book to Marie.'

### C. Summary and concluding remark

The previous subsections have shown that the default placement of sentence accent is on the most deeply embedded constituent that may carry a word accent in the surface structure of the clause (or, alternatively, a prosodic structure derived from it by the elimination of phonetically empty nodes). Default sentence accent allows an interpretation of the full lexical domain as new-information focus, while the alternative placements of main accent result in a more restricted focus interpretation. The discussion was confined to main clauses with at least one object because in this way we were able to put aside a number of intricate questions concerning the accentuation of subjects that do not immediately concern us here. For example, subjects in clause-initial position typically function as an aboutness topic or a contrastive topic/focus, and are therefore also marked with a special accent (cf. Section 11.3.3, sub IV), which gives rise to the so-called intonational hat contour found in many Dutch declarative main clauses. In question-answer pairs such as (31b) the selection of the new-information focus can be established in a run-of-the-mill fashion on the basis of the location of the sentence accent.

- (31) a. *Waarom is Jan er niet?*  
       *why is Jan here not*  
       ‘Why isn’t Jan here?’  
       b. *JAN ligt met griep in BED.*  
       *Jan lies with.the.flu in bed*  
       ‘Jan is lying in bed with the flu.’

It has been observed, however, that certain simple monadic constructions with a single accent on the subject may be interpreted as “all new-information focus”; this is illustrated by the question-answer pair in (32). This runs afoul of Cinque’s (1993) hypothesis that stress prominence is a reflection of depth of embedding, while it can be accounted for by, e.g., Baart’s (1987) earlier proposal that new-information focus is always projected from one of the verb’s arguments.

- (32) a. *Waarom ben je zo vroeg thuis?*  
       *why are you that early home*  
       ‘Why are you home that early?’  
       b. *De JUF was ziek.*  
       *the teacher<sub>fem.</sub> was ill*

We will not digress on cases such as (32b) any further because the accent in (32b) may be different from default sentence accent and the phenomenon is restricted to simple monadic constructions for reasons not well understood. We refer the reader to Verhagen (1986), Baart (1987), Gussenhoven (1992), Cinque (1993), and references cited there for extensive, sometimes conflicting discussion of such cases.

### IV. Conclusion

Although it is well-known that Dutch has a relatively free word order in its middle field, the factors determining the various orders in actual utterances have received relatively little attention in the formal linguistic literature so far. Although interest has been growing rapidly in the last two decades, it seems fair to say that this area is

still relatively uncharted. Nevertheless, recent research has made clear that the word order variation found is not the result of a unitary process: instead of assuming one generic “scrambling” rule, it now seems uncontroversial that various independent movement rules are at work in the derivation of the word orders found in actual utterances.

### 13.2. A-Scrambling: nominal argument shift

Dutch allows a wide variety of word orders in the middle field of the clause. This subsection discusses the relative order of nominal arguments and °clausal adverbs such as *waarschijnlijk* ‘probably’. All nominal arguments of the main verb may either precede or follow such adverbs, which is illustrated in (33) by means of a direct object and a subject. We will see that the word order variation in (33) is not free but restricted by information-structural considerations, namely the division between PRESUPPOSITION (discourse-old information) and FOCUS (discourse-new information); cf. Van den Berg (1978), De Haan (1979) and Verhagen (1979/1986).

- (33) a. Marie wil <het boek> waarschijnlijk <het boek> kopen.  
 Marie wants the book probably buy  
 ‘Marie probably wants to buy the book.’  
 b. Morgen zal <die vrouw> waarschijnlijk <die vrouw > het boek kopen.  
 tomorrow will that woman probably the book buy  
 ‘Tomorrow that woman will probably buy the book.’

There are various analyses available for the word order variations in (33); see the reviews in the introduction to Corver & Van Riemsdijk (1994) and Broekhuis (2007/2008: Section 2.1). It has been claimed, for instance, that the orders in (33a) are not related to movement of the object. One version of this claim can be found in Neeleman (1994a/1994b), where it is claimed that both structures in (33) can be base-generated. We will refer to this as the FLEXIBLE BASE-GENERATION approach.

- (34) • Flexible base-generation approach  
 a. Marie wil [<sub>V</sub> waarschijnlijk [<sub>V</sub> dat boek kopen]]  
 b. Marie wil [<sub>V</sub> dat boek [<sub>V</sub> waarschijnlijk kopen]]

Another slightly more complex version of this claim is found in Vanden Wyngaerd (1988/1989), where it is claimed that the object obligatorily moves into a designated accusative case position, which is indicated in (35) as the specifier of XP. The word order variation is accounted for by assuming that the clausal adverb can be generated in different base-positions: it can be adjoined either to VP or to XP. We will refer to this as the FLEXIBLE MODIFICATION approach; see Booij (1974) for an earlier proposal with similar properties.

- (35) • Flexible modification approach  
 a. Marie wil [<sub>XP</sub> waarschijnlijk [<sub>XP</sub> het boek<sub>i</sub> X [<sub>VP</sub> t<sub>i</sub> kopen]]]  
 b. Marie wil [<sub>XP</sub> het boek<sub>i</sub> X [<sub>VP</sub> waarschijnlijk [<sub>VP</sub> t<sub>i</sub> kopen]]]

This section will opt for a movement analysis: we assume that the nominal arguments are generated to the right of the clausal adverb within the lexical domain

of the clause but that they shift under certain conditions into a more leftward position in the functional domain to the left of the clausal adverbs.

- (36) • Flexible movement approach (to be revised)
- a. Marie wil [<sub>VP</sub> waarschijnlijk [<sub>VP</sub> dat boek kopen]]
  - b. Marie wil [<sub>XP</sub> dat boek<sub>i</sub> X [<sub>VP</sub> waarschijnlijk [<sub>VP</sub> t<sub>i</sub> kopen]]]

The details of this analysis, which we will refer to as the FLEXIBLE MOVEMENT approach, will be fleshed out in more detail in Subsection I; this subsection will also show that there are empirical reasons for preferring the flexible movement approach to the two alternative approaches. Subsection II discusses a concomitant effect of nominal argument shift on the intonation pattern of the clause: while non-shifted arguments can be assigned sentence accent, shifted arguments cannot. We will argue that this can also be used as an argument in favor of the flexible movement approach. Having thus firmly established that nominal argument shift is derived by movement, Subsection III will argue that this movement is of the same type as found in, e.g., passive constructions: we are dealing with A-movement.

#### *I. A flexible movement approach to nominal argument shift*

This subsection provides a number of empirical arguments in favor of a flexible movement approach to nominal argument shift. Subsection A starts by arguing that object shift involves leftward movement: objects move into some landing site that is located higher than (that is, to the left of) the base-position of the subject; subjects move into the regular subject position right-adjacent to the complementizer/finite verb in second position (the specifier of TP). Subsection B continues by showing that the movement is restricted by the information structure of the clause: nominal argument shift only applies if the argument is part of the presupposition (discourse-old information) of the clause. Subsection C concludes by discussing a word order restriction on the output structures of nominal argument shift. Some of the issues addressed in the following subsections are discussed more extensively in Sections N8.1.3 and N8.1.4, but are briefly repeated here for convenience.

#### *A. Two empirical arguments in favor of the flexible movement approach*

This subsection provides a review of two classical empirical arguments in favor of a movement analysis to nominal argument shift: *Wat voor* split and VP-topicalization.

##### *I. Wat voor split*

The standard argument in favor of a movement analysis of nominal argument shift is that placement of the nominal argument in front of the clausal adverb gives rise to a °freezing effect. We demonstrate this in (37) by means of the so-called *wat voor* split. Example (37a) first shows that the string *wat voor een boek* can be fronted as a whole and should therefore be considered a phrase; the full string functions as a direct object. This, in turn, strongly suggests that the split in (37b) is derived by *wh*-extraction of *wat* from the *wat voor*-phrase. The acceptability contrast between the two (b)-examples shows that the *wat voor* split requires the remnant of the direct object to follow the modal adverb *waarschijnlijk* ‘probably’; cf. Den Besten (1985). If the word order difference between the (b)-examples is indeed related by leftward

movement of the direct object across the clausal adverb, the unacceptability of (37b') can be accounted for by appealing to freezing: the *wh*-element *wat* has been extracted from a moved phrase.

- (37) a. Wat voor een boek zal Marie waarschijnlijk kopen?  
 what for a book will Marie probably buy  
 'What kind of book will Marie probably buy?'  
 b. Wat zal Marie waarschijnlijk voor een boek kopen?  
 what will Marie probably for a book buy  
 b'. \*Wat zal Marie voor een boek waarschijnlijk kopen?  
 what will Marie for a book probably buy

Den Besten (1985) also claims that the *wat voor* split is categorically excluded for subjects of transitive verbs but Reuland (1985), Broekhuis (1987/1992), De Hoop (1992) and Neeleman (1994a) have shown that the split is possible if the subject is not in the regular subject position but occupies a position more to the right; this is clear from the fact that the split is possible if the regular subject position in (38b) is filled by the °expletive *er*, but not if the expletive is absent.

- (38) a. Wat voor vogels zullen (er) je voedertafel bezoeken?  
 what for birds will there your bird.table visit  
 'What kind of birds will visit your bird table?'  
 b. Wat zullen ??(er) voor vogels je voedertafel bezoeken?  
 what will there for birds your bird.table visit  
 'What kind of birds will visit your bird table?'

This suggests that the subject is moved into the regular subject position from a more deeply embedded (more rightward) base-position in the clause. The introduction to this chapter has shown that in current generative grammar it is generally assumed that this base-position is the specifier of the light verb *v*, as indicated in (39).

- (39) [CP ... C [TP ... T [XP ... X [vP Subject v [VP ... V ... ]]]]]

Example (33b) has further shown that subject shift may cross the clausal adverb *waarschijnlijk* 'probably', for which reason we have assumed that such adverbs demarcate the left boundary of the lexical domain (which is now taken to be the *vP*). If so, the movement of the object in (33a) also targets a position in the functional domain of the clause. A currently more or less standard assumption is that both types of nominal argument shift are motivated by case assignment: the subject and the object (optionally) move into the specifier of some functional head that is responsible for structural case assignment: T for nominative case and some functional head X for °accusative case. The many different proposals concerning the nature of X need not concern us here; we will therefore not digress on what X is and refer the reader to Broekhuis (2008: Section 3.1) for a review of a number of recent proposals (including proposals that dispense with the category X altogether).

## (40) • Flexible movement approach

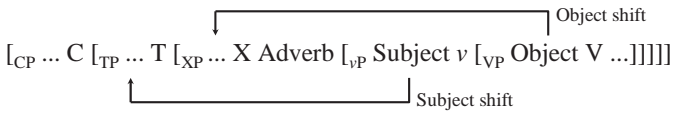

For completeness' sake, we want to conclude the discussion of the *wat voor* split by pointing out that it is not clear whether freezing should really be held responsible for the unacceptability of example (37b') and example (38b) without the expletive *er*. The reason for this is that interrogative *wat voor*-phrases are non-D-linked and this may simply block object/subject shift; that nominal argument shift of *wat voor*-phrases is indeed impossible is strongly suggested by the sharp acceptability contrast between the two multiple *wh*-questions in (41).

- (41) a. Wie zal waarschijnlijk wat voor boek kopen?  
 who will probably what for book buy  
 'Who will probably buy what kind of book?'  
 b. \*Wie zal wat voor boek waarschijnlijk kopen?  
 who will what for book probably buy

Notwithstanding this, the absence of a freezing effect in (37b) and (38b) with the expletive still supports the claim that remnants of *wat voor*-phrases should be located within the lexical domain of the clause, and hence also the claim that the subject and the object are base-generated within *vP*.

## 2. VP-topicalization

Another classic argument in favor of a movement analysis of nominal argument shift involves VP-topicalization; see De Haan (1979) and Webelhuth & Den Besten (1987/1990). Since nominal argument shift is optional, the analysis in (40) correctly predicts that VP-topicalization may either pied pipe or strand the direct object.

- (42) a. Marie wil <het boek> waarschijnlijk <het boek> kopen.  
 Marie wants the book probably buy  
 'Marie probably wants to buy the book.'  
 b. [<sub>VP</sub> Het boek kopen] wil Marie waarschijnlijk <sub>t<sub>VP</sub></sub>.  
 the book buy wants Marie probably  
 b'. [<sub>VP</sub> <sub>t<sub>i</sub></sub> Kopen] wil Marie het boek<sub>i</sub> waarschijnlijk.  
 buy wants Marie the book probably

The analysis in (40) further accounts for the fact illustrated in (43) that VP-topicalization cannot strand the object in a position following the clause adverb, as there simply is no landing site for the object there; Section 13.3.2 will return to the fact that (43) is acceptable if the object is contrastively accented.

- (43) \*<sub>[VP t<sub>i</sub> Kopen]</sub> wil Marie waarschijnlijk het boek<sub>i</sub> <sub>t<sub>VP</sub></sub>.  
 buy wants Marie probably the book

It should be noted that the acceptability contrast between of (42b') and (43) is a problem for the flexible modification approach in (35), repeated here as (44), according to which the object is *obligatorily* moved into its case position, as this



would allow us to derive both (42b') and (43) by means of VP-topicalization: the former can be derived from (44b) and the latter from (44a).

- (44) • Flexible modification approach
- a. Marie wil [<sub>XP</sub> waarschijnlijk [<sub>XP</sub> het boek<sub>i</sub> X [<sub>VP</sub> t<sub>i</sub> kopen]]]
  - b. Marie wil [<sub>XP</sub> het boek<sub>i</sub> X [<sub>VP</sub> waarschijnlijk [<sub>VP</sub> t<sub>i</sub> kopen]]]

The acceptability contrast between (42b') and (43) also poses a serious problem for the flexible base-generation approach in (45) because topicalization is often claimed to involve *maximal projections* only; if so, (42b') and (43) are both predicted to be ungrammatical, as they can only be derived by movement of the verbal *head* in isolation. If we do allow V-topicalization, there still is a problem because we then wrongly predict both (42b') and (43) to be acceptable as there would be no *a priori* reason for assuming that (43) cannot be derived from (45a) by V-topicalization.

- (45) • Flexible base-generation approach
- a. Marie wil [<sub>V'</sub> waarschijnlijk [<sub>V'</sub> het boek kopen]]
  - b. Marie wil [<sub>V'</sub> het boek [<sub>V'</sub> waarschijnlijk kopen]]

The flexible movement approach in (40) can also easily account for the fact that it is not possible to pied pipe clausal adverbs by pointing to the fact that these are not included in the lexical projection of the verb (that is, *vP*); cf. Section 8.4.

- (46) a. \*[Waarschijnlijk het boek kopen] wil Marie.  
 b. \*[Het boek waarschijnlijk kopen] wil Marie.  
 c. \*[Waarschijnlijk kopen] wil Marie het boek.

The flexible modification approach cannot account for the unacceptability of the examples in (46). The reason is that this approach can only account for the acceptability of the examples in (42b&b') by assuming that VP-topicalization can affect either XP or VP in (44). Consequently, it should be possible to derive example (46a) from (44a) by topicalization of the higher segment of XP, example (46b) from (44b) by topicalization of the higher segment of XP, and (46c) from (44b) by topicalization of the lower segment of XP. Even if we assumed that only the lower segments of XP and VP can be topicalized, the unacceptability of example (46b) would remain a problem. Similar problems arise for the flexible base-generation approach, as it should be possible to derive the examples (46a) and (46b) from, respectively, (45a) and (45b) by topicalization of the higher segments of V', and (46c) from (45b) by topicalization of the lower segment of V'. Even if we assume that only the lower segments of XP and VP can be topicalized, an option that should be allowed in order to make it possible to derive example (42b) from (45a), the unacceptability of (46c) would remain a problem. We conclude from this that the flexible modification and the flexible base-generation approach can only account for the unacceptability of the examples in (46) by appealing to *ad hoc* restrictions on what can or cannot be topicalized; the VP-topicalization data thus favor the flexible movement approach.

## B. Information-structural restrictions on nominal argument shift

Example (33a), repeated here as (47a), shows that the direct object *het boek* ‘the book’ may either precede or follow the clausal adverb *waarschijnlijk* ‘probably’. Although this suggests that object shift is optional, the examples in (47b&c) show that this is not always correct: indefinite direct objects must follow while definite object pronouns must precede the clausal adverb.

- (47) a. dat Marie <het boek> waarschijnlijk <het boek> koopt.  
 that Marie the book probably buys  
 ‘that Marie will probably buy the book.’
- b. dat Marie <\*een boek> waarschijnlijk <een boek> koopt.  
 that Marie a book probably buys  
 ‘that Marie will probably buy a book.’
- c. dat Marie <het> waarschijnlijk <\*het> koopt.  
 that Marie it probably buys  
 ‘that Marie will probably buy it.’

In fact, the two orders in (47a) are not always equally felicitous either. The order in which the direct object precedes the clausal adverb is normally used if the referent of the noun phrase is already part of the domain of discourse; cf. Verhagen (1986). This is illustrated by the question-answer pair in (48): due to the fact that the direct object was already introduced as a discourse topic in question (48a), it precedes the adverb in answer (48b). Note that we abstract away from the fact that there is an even better way of answering question (48a): by substituting the pronoun *het* ‘it’ for the noun phrase *het boek* ‘the book’.

- (48) a. Wat doet Marie met het boek? [question]  
 what does Marie with the book  
 ‘What is Marie doing with the book?’
- b. Ik denk dat ze <het boek> waarschijnlijk <<sup>#</sup>het boek> koopt. [answer]  
 I think that she the book probably buys  
 ‘I think that she’ll probably buy the book.’

When uttered out-of-the-blue, a question such as (49a) requires an answer in which the direct object provides new information and follows the clausal adverb; the order in which the object precedes the adverb is possible only if the referent of the direct object is already part of the domain of discourse, for example, when the speaker and the addressee are discussing Jan’s wish list, which includes a specific book title.

- (49) a. Wat koopt Marie voor Jan? [question]  
 what buys Marie for Jan  
 ‘What will Marie buy for Jan?’
- b. Ik denk dat ze <<sup>#</sup>het boek> waarschijnlijk <het boek> koopt. [answer]  
 I think that she the book probably buys  
 ‘I think that she’ll probably buy the book.’

The discussion above shows that direct objects preceding the clausal adverb refer to discourse-old information, whereas direct objects following the clausal adverb refer to discourse-new information. Since definite pronouns and indefinite noun phrases

typically refer to, respectively, discourse-old and discourse-new information, their placement relative to the clausal adverb in the examples in (47) follows naturally. Another fact that follows naturally from this information-structural restriction on argument placement is that epithets always precede clausal adverbs; they always refer to an active discourse topic.

- (50)     dat Jan <de etter>                 waarschijnlijk <\*de etter> haat.  
           that Jan the son.of.a.bitch probably                         hates  
           ‘that Jan probably hates the son of a bitch.’

It should be noted, however, that the notion of discourse-new information should be taken quite broadly in that it is not confined to the referential properties of the noun phrase. An example illustrating this, inspired by Verhagen (1986:106ff.), is given in (51). Although the referent of the noun phrase *de verkeerde* ‘the wrong person’ is clearly identifiable for both participants, the neutral continuation of the discourse is as given in (51b): this is due to the fact that Peter is now characterized as “the wrong person to give the relevant information to”. Note in passing that example (51b’) is possible with a contrastive accent on the noun phrase, in which case this utterance is likely to be followed by another one revealing the identity of the person that should have been informed.

- (51) a. Ik heb het aan Peter verteld.   [speaker A]  
        I have it to Peter told  
        ‘I have told it to Peter.’  
        b. Dan heb je waarschijnlijk de verkeerde ingelicht.                         [speaker B]  
           then have you probably the wrong.one prt.-informed  
           ‘Then you have probably informed the wrong person.’  
        b’. \*Dan heb je de verkeerde waarschijnlijk ingelicht.                         [speaker B]  
           then have you the wrong.one probably prt.-informed

The examples in (52) show that subjects behave in essentially the same way as the objects in (47); cf. Van den Berg (1978). This is slightly obscured, however, by a complicating factor, namely that indefinite subjects may precede the clausal adverb if they are interpreted as specific (known to the speaker but not to the addressee) or if they are part of a generic sentence. We will ignore this here but return to the distinction between specific and non-specific indefinite subjects in Subsection C.

- (52) a. dat <die vrouw> waarschijnlijk <die vrouw> het boek koopt.  
           that that woman probably                         the book buys  
           ‘that that woman will probably buy the book.’  
        b. dat <<sup>#</sup>een vrouw> waarschijnlijk <een vrouw> het boek koopt.  
           that a woman probably                         the book buys  
           ‘that a woman will probably buy the book.’  
        c. dat <ze> waarschijnlijk <\*ze> het boek koopt.  
           that she probably                         the book buys  
           ‘that she’ll probably buy the book.’

The discussion above has shown that the relative order of the object/subject and the clausal adverb is sensitive to the information-structural function of the object/subject. This favors an approach in which the restriction on word order is formulated in terms of properties of the subject/object and thereby again disfavors the flexible modification approach in (35), according to which the word order variation is due to alternative placements of the adverb. The flexible modification approach also runs up against a contradiction concerning the placement of clausal adverbs relative to the regular subject position, the specifier of TP. Consider the expletive constructions in (53). If we adopt the standard assumption that the expletive *er* occupies the regular subject position, which is corroborated by the fact that it is right-adjacent to the complementizer *dat*, the acceptability contrast between the two examples in (53) shows that clausal adverbs must follow this subject position.

- (53) a. *dat er waarschijnlijk een man op straat loopt.*  
 that there probably a man in.the.street walks  
 ‘that there is probably a man walking in the street.’  
 b. \**dat waarschijnlijk er een man op straat loopt*

The conclusion that clausal adverbs cannot be located in front of the regular subject position makes it very unlikely that the order variation in (52a) can be accounted for by assuming variable base-positions for the modal adverb, as suggested by the line of reasoning found in Vanden Wyngaerd (1989): if the subject is to occupy the regular subject position in order to receive nominative case, the order in an example such as *dat waarschijnlijk die man op straat loopt* ‘that that man is probably walking in the street’ would imply that the clausal adverb can precede the regular subject position, contrary to fact, as shown by (53b). The resulting contradiction does not arise if we assume subject shift; see Broekhuis (2009b) and Vanden Wyngaerd (2009) for more discussion.

### *C. Interaction of different types of argument shift*

If we adopt the claim that nominal argument shift targets a position in the functional domain of the clause where the subject/object can be assigned case, we can summarize the findings from Subsection B as in (54); see Broekhuis (2008:ch.3), De Hoop (1992:ch.3) and Delfitto & Corver (1998) for somewhat different implementations of the same idea.

- (54) • Information-structural restrictions on nominal argument shift:  
 a. Nominal arguments expressing discourse-new information stay within the lexical domain.  
 b. Nominal arguments expressing discourse-old information move into their case position in the functional domain of the clause.

Now consider again the derivation suggested in (40), repeated here as (55). This derivation, in tandem with the two generalizations in (54), predicts that an object expressing discourse-old information will cross a subject that expresses discourse-new information.



Although this prediction is more or less accurate for languages like German, it is clearly wrong for Standard Dutch, since in the middle field of the clause the subject normally precedes the direct object, as stated in the restriction on linear word order in (56): see, e.g., De Haan (1979:ch.4), Haegeman (1993a/1995), Williams (2003) and Müller (2000/2001) for extensive discussion of this restriction.

- (56) Ordering restriction on nominal argument shift in Standard Dutch: nominal argument shift does not affect the unmarked order of the nominal arguments (agent > goal > theme).

The word order restriction in (56) can only operate in full force if one of the generalizations in (54) is violated. The discussion in the following subsections will show that this is indeed what we find; cf. Broekhuis (2008/2009a).

1. *Direct object and subject shift*

Example (57a) shows again that definite subjects may be located to the right of clausal adverbs like *waarschijnlijk* if they are part of the focus of the clause, that is, refer to discourse-new information. The examples in (57b&c) show that the subject and the object can both shift to the left of the clausal adverb provided they are part of the presupposition of the clause. The effect of the ordering restriction on nominal argument shift in (56) is illustrated by (57d); this example shows that a presuppositional object cannot shift across the subject if the latter is part of the focus of the clause and thus has to follow the modal adverb. This means that example (57a) is information-structurally ambiguous in that it also allows the direct object to be part of the presupposition of the clause; since the discourse-old object occupies a position within the lexical domain, this results in a violation of restriction (54b).

- (57) a. dat waarschijnlijk de jongens dit boek gelezen hebben.  
           that probably the boys this book read have  
           ‘that the boys have probably read this book.’  
       b. dat de jongens waarschijnlijk dit boek gelezen hebben.  
       c. dat de jongens dit boek waarschijnlijk gelezen hebben.  
       d. \*dat dit boek waarschijnlijk de jongens gelezen hebben.

The results are different if we replace the direct object *dit boek* ‘this book’ by the pronoun *het* ‘it’. Example (58a) first shows that the object pronoun differs from non-pronominal objects in that it cannot remain within the lexical domain of the clause if the subject is part of the focus of the clause. Example (58b) shows that it behaves like non-pronominal objects in that it cannot cross the subject, but (58c) shows that it differs from non-pronominal objects in that it is able to push the subject up into the regular subject position of the clause. This means that the subject in (58c) can be interpreted as referring to discourse-new information in violation of the restriction in (54a), as is clear from the fact that this example can be used as an answer to the question *Wie hebben het boek gelezen?* ‘Who have read the book?’.

- (58) a. \*dat <waarschijnlijk> de jongens het gelezen hebben.  
           that probably           the boys it read have  
       b. \*dat het <waarschijnlijk> de jongens gelezen hebben.  
           that it probably           the boys read have  
       c. dat de jongens het waarschijnlijk gelezen hebben.  
           that the boys it probably read have  
           ‘that the boys probably have read it.’

It should further be noted that examples such as (58a) become fully acceptable if the subject is given contrastive stress; this shows that in such cases the subject may block object shift of the pronominal object in violation of the information-structural restrictions in (54b); we refer the reader to Section 13.3 for a discussion of the placement of contrastively focused phrases.

- (59) dat waarschijnlijk de JONGENS het gelezen hebben.  
       that probably the boys it read have  
       ‘that the boys have probably read it.’

We find more or less the same pattern with indefinite subjects. The situation is somewhat complicated, however, by the fact that, depending on its placement with respect to the clausal adverb, the subject can receive a non-specific interpretation (unknown to speaker and hearer) or a specific interpretation (known to the speaker but unknown to the hearer); if the indefinite subject *twee jongens* in (60) follows the clausal adverb *waarschijnlijk* ‘probably’, it is preferably interpreted as non-specific, while *twee jongens* can only be interpreted as specific if it precedes *waarschijnlijk* (see also N8.1.4, sub I).

- (60) a. dat waarschijnlijk twee jongens dit boek gelezen hebben.  
           that probably two boys this book read have  
           Ambiguous: ‘that two (of the) boys have probably read this book.’  
       b. dat twee jongens waarschijnlijk dit boek gelezen hebben.  
           that two of the boys probably this book read have  
           Specific only: ‘that two of the boys have probably read this book.’

The result changes again if we replace the direct object *het boek* ‘the book’ by the pronoun *het* ‘it’. Placement of the indefinite subject after the clausal adverb, as in (61a), again requires the subject to be assigned contrastive stress; in case of a more neutral intonation pattern the pronoun pushes the subject up into the regular subject position right-adjacent to the complementizer, as in (61b). The fact that the subject in (61b) may provide discourse-new information again violates the information-structural restriction in (54a), and the fact that the contractively stressed subject in (61a) is able to block object shift of the pronoun violates the restriction in (54b).

- (61) a. dat waarschijnlijk twee JONGENS/\*jongens het gelezen hebben.  
           that probably two boys it read have  
           ‘that two boys (not girls) have probably read it.’  
       b. dat twee jongens het waarschijnlijk gelezen hebben.  
           that two boys it probably read have  
           Ambiguous: ‘that two (of the) boys have probably read it.’

The data above show that referential object pronouns may push up subjects that express discourse-new information into the regular subject position adjacent to the complementizer, in violation of the information-structural restriction in (54a). Object shift of the pronoun can also be blocked in violation of the information-structural restriction in (54b) if the subject is assigned contrastive focus accent. This shows that the restrictions in (54) are not absolute, but can be overridden in order to satisfy the “stronger” word order restriction in (56). This suffices to show that there is a complex set of factors interacting (in the sense of optimality theory developed by Prince & Smolensky 2004) in determining the surface position of the nominal arguments of the clause.

## 2. *Direct object and indirect object shift*

The discussion of the interaction of object and subject shift in Subsection 1 has shown that the information-structural restrictions in (54) can be overridden by the word order restriction in (56). The same can be shown by the interaction of indirect object and direct object shift. Since this is also discussed in detail in Section N8.1.3, sub V, we will confine ourselves here to a brief review of the relevant data. The examples in (62) show more or less the same as the examples in (57); although the direct and the indirect object can both shift across the modal adverb, the direct object cannot cross the indirect object in its base position.

- (62) a. dat hij waarschijnlijk zijn moeder het boek heeft gegeven.  
           that he probably his mother the book has given  
           ‘that he has probably given his mother the book.’  
       b. dat hij zijn moeder waarschijnlijk het boek heeft gegeven.  
       c. dat hij zijn moeder het boek waarschijnlijk heeft gegeven.  
       d. \*dat hij het boek waarschijnlijk zijn moeder heeft gegeven.

The examples in (63) show more or less the same as the examples in (58). Example (63a) first shows that the object pronoun differs from non-pronominal direct objects in that it cannot remain within the lexical domain of the clause if the indirect object is part of the focus of the clause. Example (63b) shows that the object pronoun behaves like non-pronominal direct objects in that it cannot cross the indirect object, while (63c) shows that it differs from them in that it is able to push the indirect object up into the functional domain of the clause. As in the cases discussed in Subsection 1, the judgments only hold under a non-contrastive intonation pattern, as the orders in (63b&c) become acceptable if the indirect object is assigned a contrastive focus accent.

- (63) a. \*dat hij waarschijnlijk zijn moeder het heeft gegeven.  
       b. \*dat hij het waarschijnlijk zijn moeder heeft gegeven.  
       c. ?dat hij zijn moeder het waarschijnlijk heeft gegeven.  
           that he his mother it probably has given  
           ‘that he probably has given it to his mother.’

The fact that example (63c) is still somewhat marked may be related to the fact the pronoun may precede the indirect object in (63c), *dat hij het zijn moeder waarschijnlijk heeft gegeven*, but we postpone discussion of this issue to Section



13.4. The markedness of (63c) may also be related to the fact that it competes with the periphrastic construction *dat hij het waarschijnlijk aan zijn moeder heeft gegeven* ‘that he has probably given it to his mother’, which does not run afoul of the information-structural restriction in (54a). The markedness of (64a) with a contrastively stressed indirect object blocking object shift of the pronoun *het* ‘it’ may have a similar reason: the periphrastic construction in (64b) does not induce a violation of the information-structural restriction in (54b) which we see in (64a).

- (64) a. <sup>?</sup>*dat hij waarschijnlijk zijn MOEDER het heeft gegeven.*  
           that he probably his mother it has given  
       b. *dat hij het waarschijnlijk aan zijn MOEDER heeft gegeven.*  
           that he it probably to his mother has given  
           ‘that he probably has given it to his mother.’

For completeness’ sake, it should be noted that Dutch differs markedly from German, which does allow the object to cross the indirect object. This is illustrated in (65) by means of examples taken from Vikner (1994).

- (65) a. *dass Peter wirklich Maria das Buch gezeigt hat.* [German]  
           that Peter really Maria the book shown has  
       b. *dass Peter Maria wirklich t<sub>IO</sub> das Buch gezeigt hat.*  
       c. *dass Peter Maria das Buch wirklich t<sub>IO</sub> t<sub>DO</sub> gezeigt hat.*  
       d. *dass Peter das Buch wirklich Maria t<sub>DO</sub> gezeigt hat.*

### 3. Indirect object and subject shift

The previous two subsections have argued that the ordering restriction on nominal argument shift in (56) cannot be violated in Dutch, contrary to what is the case in German. This subsection will discuss an apparent counterexample to this claim. The problem is illustrated in example (66), which shows that passive ditransitive and dyadic unaccusative constructions do not obey restriction (56); on the assumption that the orders in the primeless examples are unmarked, we would expect the primed examples to be unacceptable under a neutral, non-contrastive intonation pattern (and vice versa) but both orders seem fully acceptable (although some speakers may prefer a periphrastic indirect object to the nominal indirect object in (66a’)).

- (66) a. *dat Els<sub>dat</sub> de boeken<sub>nom</sub> worden aangeboden.* [passive]  
           that Els the books are prt.-offered  
           ‘that the books will be offered to Els.’  
       a’. *dat de boeken<sub>nom</sub> Els<sub>dat</sub> worden aangeboden.*  
       b. *dat de jongens<sub>dat</sub> het tochtje<sub>nom</sub> bevallen is.* [NOM-DAT verb]  
           that the boys the trip pleased is  
           ‘that the trip has pleased the boys.’  
       b’. *dat het tochtje<sub>nom</sub> de jongens<sub>dat</sub> bevallen is.*  
       c. *dat de gasten<sub>dat</sub> de soep<sub>nom</sub> gesmaakt heeft.* [NOM-DAT verb]  
           that the guests the soup tasted has  
           ‘that the soup has pleased the guests.’  
       c’. *dat de soep<sub>nom</sub> de gasten<sub>dat</sub> gesmaakt heeft.*

It seems, however, that the primed examples impose specific restrictions on the placement of clausal adverbs like *waarschijnlijk* ‘probably’ under a neutral intonation pattern: the number signs are used to indicate that the indirect objects may follow the adverb only if they are assigned contrastive accent.

- (67) a. dat de boeken <Els> waarschijnlijk <<sup>#</sup>Els> worden aangeboden.  
 that the books Els probably are prt.-offered  
 ‘that the books will probably be offered to Els.’
- b. dat het tochtje <de jongens> waarschijnlijk <<sup>#</sup>de jongens> bevallen is.  
 that the trip the boys probably pleased is  
 ‘that the trip has probably pleased the boys.’
- c. dat de soep <de gasten> waarschijnlijk <<sup>#</sup>de gasten> gesmaakt heeft.  
 that the soup the guests probably tasted has  
 ‘that the soup has probably pleased the guests.’

Since Section 13.3 will show that contrastively accented phrases are at least sometimes external to the lexical domain of the clause, the conclusion that presents itself is that the ordering restriction in (56) is only valid to the extent that it prohibits nominal argument shift across another nominal argument that remains within the lexical domain of the clause; for independent evidence in favor of this claim, we refer the reader to the discussion about the interaction between nominal argument shift and *wh*-movement in Section N8.1.3, sub V.

#### D. Conclusion

The discussion in this subsection has shown that nominal argument shift is regulated by the information-structural restrictions in (54) in tandem with the word order restriction in (56). According to (54) nominal arguments move into their case-position in the functional domain of the clause if they express discourse-old information but remain within the lexical domain of the clause if they express discourse-new information. We have further seen that restriction (56) is only valid to the extent that it prohibits nominal argument shift across another nominal argument that remains within the lexical domain of the clause; the theme argument of a passive ditransitive or a dyadic unaccusative construction may cross the goal argument on its way to the regular subject position provided that the latter has undergone object shift.

Some of the topics discussed in this subsection are treated more extensively in Chapter N8. Section N8.1.3 focuses on object shift and addresses issues more specifically related to special types of nominal objects: noun phrases with a generic or partitive reading, indefinite noun phrases with a specific or non-specific reading, quantified noun phrases, etc. Section N8.1.3 also discusses the placement of nominal objects relative to a wider range of adverbial phrases including manner adverbs, negation and temporal/locational adverbs preceding the modal adverbs. Section N8.1.4 more specifically deals with issues related to subject shift in expletive *er* ‘there’ constructions.

## II. Nominal argument shift and the location of sentence accent

The introduction to this section mentioned that there are three approaches to nominal argument shift. We adopted the flexible movement approach, according to which the nominal argument is optionally moved out of the lexical domain into a designated case position in the functional domain of the clause; we have further shown that there are empirical reasons for preferring this approach to the flexible base-generation and flexible modification approaches. This subsection provides additional reasons for rejecting these two alternative approaches.

Consider the (a)-examples in (68) which show that object shift goes hand-in-hand with a change in intonation pattern: while the sentence accent (indicated by small caps) is assigned to the direct object if it is part of the focus of the clause, it cannot be assigned to the direct object if it is part of the presupposition of the clause. The (b)-examples show that the two intonations patterns also occur with the same interpretative effect if the adverb is not present. The symbols  $\subset$  and  $\not\subset$  are used to indicate “is (not) part of”.

- (68) a. dat Peter waarschijnlijk het BOEK koopt. [object  $\subset$  focus]  
           that Peter probably the book buys  
       a'. dat Peter het boek waarschijnlijk KOOPT. [object  $\not\subset$  focus]  
           that Peter the book probably buys  
       b. dat Peter het BOEK koopt. [object  $\subset$  focus]  
           that Peter the book buys  
       b'. dat Peter het boek KOOPT. [object  $\not\subset$  focus]  
           that Peter the book buys

The examples in (69), taken from Verhagen (1986), show more or less the same thing. These examples confirm the claim in Section N8.1.3.1, sub III, that object shift of indefinite objects with a non-specific interpretation is normally impossible, while object shift of indefinite objects with a generic (or partitive) reading is obligatory; (69a) expresses that renting *some* bigger computer is probably necessary, while (69a') expresses that *any* computer bigger than a certain contextually defined standard should probably be rented (not bought). The (b)-examples illustrate again that these interpretations do not crucially depend on the presence of a clausal adverb but on the intonation pattern of the clause.

- (69) a. Daarom moet hij waarschijnlijk een grotere compUter huren.  
           therefore must he probably a bigger computer rent  
       a'. Daarom moet hij een grotere computer waarschijnlijk Huren.  
           therefore must he a bigger computer probably rent  
       b. Daarom moet hij een grotere compUter huren.  
           therefore must he a bigger computer rent  
       b'. Daarom moet hij een grotere computer Huren.  
           therefore must he a bigger computer rent

The flexible movement approach can easily account for the correlation between the intonation pattern of the clause and the interpretation of the object in (68) and (69) by adopting the claim from Section 13.1, sub III, that the sentence accent must be assigned to some element within the lexical domain (unless it is phonetically

empty). Because the shifted objects in the primed examples are not within the lexical domain, sentence accent must be assigned to the clause-final verb; see Van den Berg (1978) for the same conclusion in somewhat different theoretical terms. It is not clear whether the two alternative approaches can account for this correlation. The flexible modification approach seems to leave us empty-handed, as there is no obvious link within this approach between adverb placement and the relevant correlation between intonation and interpretation. The same holds for the flexible base-generation approach as far as the (b)-examples in (68) and (69) are concerned: because the primeless and primed examples are assigned identical syntactic structures, there is no clear syntactic property that could account for the correlation between intonation and interpretation; see Verhagen (1986: section 3.2.3) for a similar argument against Hoekstra's (1984a: section 2.7.3) hypothesis that object shift involves °adjunction to VP, which we did not discuss here.

*III. Nominal argument shift is A-movement*

Subsection IA suggested that nominal argument shift is related to case marking in that the subject and the object (optionally) move into the specifier of some functional head that is responsible for structural case assignment: T for nominative case and some functional head X for accusative case. If true, this implies that nominal argument shift involves A-movement. This is supported by the fact that this kind of movement seems to be restricted to nominal arguments, which was already noted by Kerstens (1975), Van den Berg (1978) and De Haan (1979), who proposed a transformational rule of NP-PREPOSING to account for these phenomena.

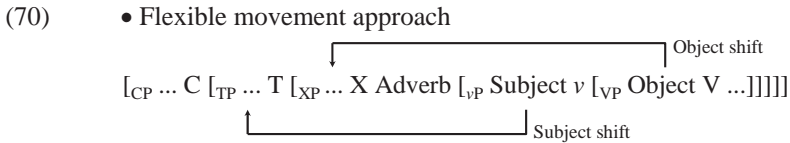

Nevertheless, it is claimed occasionally that prepositional objects may undergo the same process; see, e.g., Neeleman (1994a/1994b). An important reason for assuming that leftward movement of such PPs should be distinguished from nominal argument shift is related to the distribution of PPs containing a definite pronoun. First, recall from Subsection IB that definite subject/object pronouns normally undergo nominal argument shift because they refer to discourse-old entities. This is illustrated once more in (71a), in which the object pronoun *hem* can only follow the clausal adverb if it is assigned contrastive accent: *Jan nodigt waarschijnlijk HEM uit (niet HAAR)* ‘Jan will probably invite him (not her)’. Second, example (71b) shows that leftward movement of a complement-PP is optional if its nominal part is a definite pronoun; this clearly shows that the division between discourse-old and discourse-new information has no bearing on the positioning of PP-complements. Finally, leftward movement of the *naar*-PP produces a marked result if we replace *nauwelijks* ‘hardly’ by the prototypical clausal adverb *waarschijnlijk* ‘probably’; cf. (71b’). This shows that leftward movement of prepositional objects should be distinguished from nominal argument shift.

- (71) a. Jan nodigt <haar> waarschijnlijk <\*haar> uit.  
 Jan invites her probably prt  
 'Jan will probably invite her.'
- b. dat Jan <naar haar> nauwelijks <naar haar> kijkt.  
 that Jan at her hardly looks  
 'that Jan is hardly looking at her.'
- b'. dat Jan <?<sup>?</sup>naar haar> waarschijnlijk <naar haar> kijkt.  
 that Jan at her probably looks  
 'that Jan is probably looking at her.'

The examples in (72) further show that while shifted pronouns can be phonologically weak, the pronominal part of a shifted PP must be strong. The fact that the pronominal part can be weak if the PP follows the adverb again shows that leftward movement of prepositional objects should be distinguished from nominal argument shift; we refer the reader to Section 9.5, sub IIIA, for a more detailed discussion.

- (72) a. Jan nodigt <'r> waarschijnlijk <\*'r> uit.  
 Jan invites her probably prt  
 'Jan will probably invite her.'
- b. dat Jan <\*naar 'r> nauwelijks <naar 'r> kijkt.  
 that Jan at her hardly looks  
 'that Jan is hardly looking at her.'

Another argument in favor of an A-movement analysis of nominal argument shift can be based on anaphor °binding and °bound variable readings of pronouns. The English subject raising examples in (73) first show that A-movement is able to feed these binding relations; the crucial thing is that in the primeless examples the noun phrase is clearly located within the infinitival clause and therefore does not c-command the nominal complement of the *to*-PP, while in the primed examples the noun phrase has been A-moved into the subject position of the matrix clause and so c-commands the reciprocal/possessive pronoun from this position as a result; see Section 11.3.7, sub IIIA, for a more detailed discussion.

- (73) a. \*There<sub>i</sub> seem to *each other* [<sub>t<sub>i</sub></sub> to be *some applicants*<sub>i</sub> eligible for the job].  
 a'. *Some applicants*<sub>i</sub> seem to *each other* [<sub>t'<sub>i</sub></sub> to be <sub>t<sub>i</sub></sub> eligible for the job].  
 b. \*There<sub>i</sub> seems to *his* mother [<sub>t<sub>i</sub></sub> to be *someone* eligible for the job].  
 b'. *Someone* seems to *his* mother [<sub>t'<sub>i</sub></sub> to be <sub>t<sub>i</sub></sub> eligible for the job].

For Dutch we can show the same by using constructions with dyadic unaccusative (NOM-DAT) verbs such as *bevallen* 'to please' in (74). Section 2.1.3 has shown that (just as in the case of passive ditransitive constructions) the NOMINATIVE-DATIVE order in (74a) is the neutral one. The fact that subject shift feeds anaphor °binding therefore supports our claim that we are dealing with A-movement, that is, that subject shift targets the regular subject position; cf. Vanden Wyngaerd (1989).

- (74) a. dat <de jongen> zichzelf <\*de jongen> goed bevalt.  
 that the boy himself well pleases  
 'that the boy is quite pleased with himself.'  
 b. dat <de jongens> elkaar <\*de jongens> goed bevallen.  
 that the boys each.other well please  
 'that the boys are quite pleased with each other.'

Consequently, the fact illustrated in (75) that object shift also feeds anaphor binding and bound variable readings also strongly supports an A-movement analysis; cf. Vanden Wyngaerd (1988/1989).

- (75) a. \*Zij heeft namens *elkaar* *de jongens* gefeliciteerd.  
 she has on.behalf.of each other the boys congratulated  
 a'. Zij heeft *de jongens*<sub>i</sub> namens *elkaar* *t<sub>i</sub>* gefeliciteerd.  
 she has the boys on.behalf.of each.other congratulated  
 'She congratulated the boys on behalf of each other.'  
 b. \*Zij heeft namens *zijn* begeleider *elke jongen* gefeliciteerd.  
 she has on.behalf.of his supervisor each boy congratulated  
 b'. Zij heeft *elke jongen*<sub>i</sub> namens *zijn* begeleider *t<sub>i</sub>* gefeliciteerd.  
 she has each boy on.behalf.of his supervisor congratulated  
 'She congratulated each boys on behalf of his supervisor.'

Let us adopt the standard assumption that the direct object is base-generated within the VP while VP adverbials are adjoined to VP, as in (76a). Because the object is more deeply embedded than the adverbial phrase, the former does not c-command the latter, and this accounts for the fact illustrated in the primeless examples in (75) that the direct object cannot bind the italicized pronominal elements within the adjunct. If the vP-external landing site of object shift is an A-position, the contrast between the primeless and primed examples in (75) follows; in the resulting structure in (76b) the direct object c-commands the VP adverbial and it is consequently able to bind the italicized pronominal elements within it.

- (76) a. [<sub>VP</sub> ... v [<sub>VP</sub> Adverb [<sub>VP</sub> DO V]]]  
 b. [<sub>XP</sub> DO X [<sub>VP</sub> ... v [<sub>VP</sub> Adverb [<sub>VP</sub> *t*<sub>DO</sub> V]]]]

There are also potential problems for an A-movement analysis. The fact illustrated in (77) that leftward movement of the direct object licenses a parasitic gap is often considered an A'-movement property; cf. Bennis & Hoekstra (1984).

- (77) a. \*Zij heeft [zonder PRO *pg* aan te kijken] *de jongens* gefeliciteerd.  
 she has without prt. to look.at the boys congratulated  
 b. Zij heeft *de jongens*<sub>i</sub> [zonder PRO *pg* aan te kijken] *t<sub>i</sub>* gefeliciteerd.  
 she has the boys without prt. to look.at congratulated  
 'She congratulated the boys without looking at them.'

Example (78) shows that things turn out to be even more complicated: leftward movement of the direct object may simultaneously feed binding and license a parasitic gap. Webelhuth (1989/1992) concluded from this that the dichotomy

between A- and A'-positions is too coarse, and that we have to postulate a third, Janus-faced position that exhibits properties of both A- and A'-positions.

- (78) a. Zij heeft de jongens<sub>i</sub> [zonder *pg* aan te kijken] namens *elkaar*  
 she has the boys without prt. to look.at on.behalf.of each.other  
 gefeliciteerd.  
 congratulated  
 'She congratulated the boys on behalf of each other without looking at them.'
- b. Zij heeft *elke jongen*<sub>i</sub> [zonder *pg* aan te kijken] namens *zijn* begeleider  
 she has each boy without prt. to look.at on.behalf.of his supervisor  
 gefeliciteerd.  
 congratulated  
 'She congratulated each boy on behalf of his supervisor without looking at him.'

Examples of this sort have given rise to ardent debates on the nature of nominal argument shift and on the licensing condition for parasitic gaps but the main issues are not yet settled. For instance, the fact that infinitival clauses containing a parasitic gap normally precede PP-adjuncts containing an anaphor opens up the possibility of assuming that nominal argument shift is A-movement, which feeds anaphor binding, but that it can be followed by an additional A'-movement step, which licenses the parasitic gap; cf. Mahajan (1990/1994). We will not digress on this issue here but refer the reader to Section 11.3.7, sub III, for an extensive review of the debate.

### 13.3. A'-scrambling: negation, focus and topic movement

For a long time scrambling has been considered a unitary phenomenon. Recent research has shown, however, that we should distinguish at least two main types: A-scrambling, which is restricted to nominal arguments, and A'-scrambling, which can also be applied to other categories and non-arguments. A-scrambling was discussed in Section 13.2 and A'-scrambling will be discussed in this section.

Section 11.3 discussed various types of A'-movement involved in the formation of *wh*-questions, relative clauses, topicalization constructions, etc. These so-called *wh*-movements differ from the A'-movements to be discussed in this section in their choice of landing site: while *wh*-movement targets the clause-initial position (the specifier of CP), the movements in this section target some position in the middle field of the clause. It is often assumed that the positions targeted by A'-scrambling are the specifier positions of various functional projections in functional domain of the clause, which are indicated by XP in structure (79).

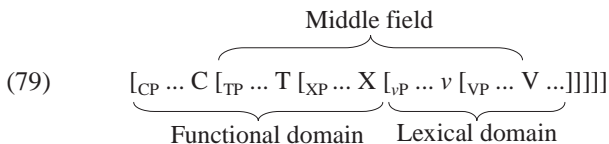

Since this section focuses on the various functional projections external to vP, we will regularly use in our syntactic representations the structure [LD ... V ...] instead of the more articulate structure [<sub>vP</sub> ... v [<sub>VP</sub> ... V ...]], in which "LD" is short for "lexical



domain". This will enable us to simplify the representations and to suppress certain issues that are not immediately relevant for our discussion, such as the fact that in (in)transitive constructions the specifier of *vP* will normally be occupied by a trace of a moved subject.

Section 11.3 has argued that the various subtypes of *wh*-movement are semantically motivated: *wh*-movement in *wh*-questions, for instance, is required because it derives an operator-variable chain in the sense of predicate calculus. The same arguably holds for the various subtypes of *A'*-scrambling discussed in this section. The examples in (80), for instance, show that negative phrases expressing sentence negation are obligatorily scrambled, which might be motivated by claiming that this movement is needed in order for negation to take °scope over the proposition expressed by the clause; cf. Haegeman (1995). Representation (80b) formally expresses this by postulating that the lexical domain of the verb is embedded in a *NegP*, the specifier of which provides a landing site for the negative phrase; see Section 13.3.1 for detailed discussion.

- (80) a. dat Jan erg dol op Peter is.  
 that Jan very fond of Peter is  
 'that Jan is very fond of Peter.'
- b. dat Jan [<sub>NegP</sub> <op niemand> Neg [<sub>LD</sub> [<sub>AP</sub> erg dol <\*op niemand>] is]].  
 that Jan of nobody very fond is  
 'that Jan isn't very fond of anybody.'

A similar approach can be taken for so-called focus and topic movement, which will be discussed in Section 13.3.2. Neeleman & Van de Koot (2008) argue that focus movement is instrumental in distinguishing contrastive foci from the backgrounds against which they are evaluated, while topic movement is instrumental in distinguishing contrastive topics from the comments that provide more information about them. This can be formally expressed as in (81), according to which the lexical domain of the verb can be embedded in a *Foc(us)P* or a *Top(ic)P*, the specifiers of which are filled by the contrastive focus/topic. Contrastive foci will be indicated by means of small caps in italics, while contrastive topics will be indicated by italics plus double underlining.

- (81) a. dat Jan [<sub>FocP</sub> [op *PETER*]<sub>i</sub> Foc [<sub>LD</sub> [<sub>AP</sub> erg dol *t*<sub>i</sub>] is]].  
 that Jan of Peter very fond is  
 'that Jan is very fond of Peter.'
- b. Ik weet niet wat Jan van Marie vindt, maar ik weet wel ...  
 I know not what Jan of Marie considers, but I know AFF  
 dat hij [<sub>TopP</sub> [op *Peter*]<sub>i</sub> Top [<sub>LD</sub> [<sub>AP</sub> erg dol *t*<sub>i</sub>] is]].  
 that he of Peter very fond is  
 'I don't know what Jan thinks of Marie but I do know that he is very fond of Peter.'

The three subtypes of *A'*-scrambling mentioned above will be discussed in the following sections. A note of caution should be sounded at this point: research on these types of scrambling is still in its infancy and many issues are not settled yet.

For example, while it seems widely accepted that negation movement is obligatory in Dutch, it is controversial whether the same is true of focus and topic movement.

### 13.3.1. Negation movement

This section discusses sentence negation, which can be expressed by the negative adverb *niet* ‘not’, but also by negative noun phrases like *niets* ‘nothing’, *niemand* ‘nobody’ and *geen N* ‘no N’, negative adverbs like *nooit* ‘never’ and *nergens* ‘nowhere’, etc. The logical formulas in (82) show that negation has scope over the full proposition expressed by the clause.

- (82) a. Jan heeft niet gewandeld.                    a'.  $\neg$ WALK(Jan)  
 Jan has not walked  
 ‘Jan hasn’t walked.’  
 b. Jan heeft niets gelezen.                    b'.  $\neg\exists x$  READ(Jan,x)  
 Jan has nothing read  
 ‘Jan hasn’t read anything.’

The discussion in this section especially focuses on the placement of negative phrases and is organized as follows. Subsection I starts by showing that there is a designated position relatively low in the functional domain of the clause where sentential negation must be expressed. Subsection II formalizes this by assuming that in negative clauses the verb’s lexical domain is the complement of the functional projection NegP; the head of this projection is phonetically empty in present-day Dutch but the specifier of this projection must be filled. The filler can be the negative adverb *niet* or a negative phrase such as *niets* ‘nothing’. We will assume that *niet* in examples such as (82a) is simply base-generated in the specifier of NegP, as indicated in the simplified structure in (83a). This is, however, not an option for a negative direct object such as *niets* ‘nothing’ in example (82b); such examples must be derived by movement (henceforth: Neg-movement) of the direct object into the specifier of NegP, as indicated by the simplified structure in (83b). Recall from the introduction to Section 13.3 that for simplicity’s sake we will represent the lexical domain of the verb as [<sub>LD</sub> ... V ...] instead of [<sub>VP</sub> ... v [<sub>VP</sub> ... V ...]], and that we ignore traces of the subject if not directly relevant for the discussion.

- (83) a. Jan heeft [<sub>NEGP</sub> niet Neg [<sub>LD</sub> gewandeld]].  
 b. Jan heeft [<sub>NEGP</sub> niets<sub>i</sub> Neg [<sub>LD</sub> *t*<sub>i</sub> gelezen]].

In some languages the meaning of example (82b) can also be expressed by the combination of a negative adverb followed by a negative polarity item. This is illustrated for English by the simplified structure in (84a). Subsection III will discuss the fact that this option is not available for Dutch if the negative adverb and the negative polarity item are part of the same clause: cf. (84b).

- (84) a. John has [<sub>NEGP</sub> not Neg [<sub>LD</sub> read anything]].  
 b. \*Jan heeft [<sub>NEGP</sub> niet Neg [<sub>LD</sub> ook maar iets gelezen]].  
 Jan has not anything read

The fact that Neg-movement is not restricted to noun phrases but can also be applied to, e.g., PPs shows that we are dealing with A'-movement. Because it is

generally assumed that A'-movement cannot be followed by A-movement, this predicts that negative subjects/direct objects normally do not undergo nominal argument shift: Subsection IV will show that this prediction is indeed borne out. Subsection V concludes by showing that negative subjects may sometimes block nominal argument shift of objects.

### 1. *The location of NegP*

Dutch negation is located relatively low in the functional domain of the clause. This is clear from the fact illustrated in (85) that the negative adverb *niet* must follow the modal adverbs, which are normally taken to demarcate the boundary of the functional and the lexical domain of the clause.

- (85)     dat Jan <\*niet> waarschijnlijk <niet> komt.  
           that Jan    not    probably                comes  
           'that Jan probably does not come.'

Sentence negation is nevertheless external to the lexical domain. This intuition is formally expressed in standard predicate calculus by giving negation  $\circ$ scope over the proposition COME(Jan), which corresponds to the lexical domain of the verb. That sentence negation is external to the lexical domain is also clear from the fact that negation behaves like modal adverbs in that it passes the  $\circ$ adverb test for clausal adverbs: example (86) shows that example (85) can be paraphrased by placing the negative adverb *niet* 'not' in a matrix clause of the form *het is ADVERB zo dat ...*

- (86)     Het is waarschijnlijk niet zo        dat Jan komt.  
           it    is probably            not the.case that Jan comes  
           'It is probably not the case that Jan will come.'

That negation is located low in the functional domain of the clause is further supported by the observation that the negative adverb *niet* follows all adverbs with the exception of the VP adverbials, that is, adverbials which are part of the lexical domain as modifiers of the predicate expressed by VP in (79); cf. Section 8.2.

- (87) a. Jan heeft [niet [<sub>LD</sub> lang gewacht]].  
           Jan has   not    long waited  
           'Jan hasn't waited long.'  
       b. Jan heeft [niet [<sub>LD</sub> zorgvuldig gelezen]].  
           Jan has   not    carefully read  
           'Jan hasn't read carefully.'

Since prepositional objects normally follow VP adverbials, it does not come as a surprise that they also follow the negative adverb *niet* in examples such as (88a). The same holds for complementives like the directional PP in (88b), which are normally left-adjacent to the clause-final verbs.

- (88) a. Jan heeft [niet [<sub>LD</sub> (lang) op zijn vader gewacht]].  
           Jan has   not    long   for his father waited  
           'Jan hasn't waited (long) for his father.'

- b. Jan is [niet [<sub>LD</sub> naar het feest gegaan]].  
 Jan is not to the party gone  
 ‘Jan hasn’t gone to the party.’

It should be noted, however, that nominal arguments cannot follow the negative adverb *niet* ‘not’ if it expresses sentence negation. This is surprising since such arguments normally can follow manner adverbs: see the contrast between the two examples in (89).

- (89) a. Jan heeft <het boek> [<sub>LD</sub> zorgvuldig <het boek> gelezen].  
 Jan has the book carefully read  
 ‘Jan has read the book carefully.’  
 b. Jan heeft <het boek> [niet [<sub>LD</sub> (zorgvuldig) <\*het boek> gelezen]].  
 Jan has the book not carefully read  
 ‘Jan hasn’t read the book (carefully).’

Apparently, there is a surface filter which prohibits a definite nominal argument (DP) in the domain of sentence negation; cf. (90a). The rationale for this filter is not immediately evident but we expect it to be pragmatic in nature: nominal arguments within the lexical domain normally express discourse-new information and it does not seem expedient or informative to negate a proposition with discourse-new information because this does not result in an update of the background (shared information) of the discourse; cf. Grice’s ‘cooperation principle. This pragmatic account may be supported by the fact that definite noun phrases can easily follow negative phrases, e.g., *Ik heb nooit het boek gelezen* ‘I have never read the book’; cf. (90b).

- (90) a. \*... [<sub>NegP</sub> niet Neg [<sub>LD</sub> ... DP ...]]  
 b. ✓... [<sub>NegP</sub> XP<sub>[+Neg]</sub> Neg [<sub>LD</sub> ... DP ...]]

A complication for the pragmatic account is that the nominal argument can occur in between a modal adverb and sentence negation, as illustrated for the direct object *het boek* in (91a). At first sight this seems to go against the earlier suggestion that the direct object must express discourse-old information in negative clauses but Section 13.3.2 will show that the position in between the modal adverb and negation is a designated position for contrastive foci, which are discourse-given in the sense that their referents are normally part of a contextually given set. Example (91b) is added for completeness’ sake, to show that nominal arguments can undergo nominal argument shift if sentence negation is expressed by the adverb *niet* ‘not’.

- (91) a. dat Jan waarschijnlijk *HET BOEK* niet gelezen heeft.  
 that Jan probably the book not read has  
 ‘that Jan probably hasn’t read the book.’  
 b. dat Jan het boek waarschijnlijk niet gelezen heeft.  
 that Jan the book probably not read has  
 ‘that Jan probably hasn’t read the book.’

For completeness’ sake, it should also be pointed out that the examples in (92) are acceptable but in these cases we are arguably dealing with constituent negation as negation takes scope over the noun phrase *het boek* and the cardinal numeral only.

- (92) a. Jan heeft niet het BOEK (maar het ARTIKEL) gelezen.  
 Jan has not the book but the article read  
 ‘Jan hasn’t read the book but the article’
- b. Jan heeft niet VIER maar VIJF boeken gekocht.  
 Jan has not four but five books bought  
 ‘Jan hasn’t read four but five books.’

If we put these potential problems surrounding surface filter (90) aside, it seems that we can safely conclude that sentence negation is external to the *vP* but lower than the modal adverbs. Haegeman (1995) argues that the negative adverb *niet* is located in the specifier and not the head of NegP, because West-Flemish can optionally express the head of NegP by means of the negative preverbal clitic *en*; this is illustrated in (93a). Example (93b), cited from Van der Horst (2008:516), shows that a similar clitic was (virtually obligatorily) used in Middle Dutch.

- (93) a. Valere en-eet nie s’oavonds. [West-Flemish]  
 Valère NEG-eat not evening  
 ‘Valère doesn’t eat in the evening.’
- b. Dit en kunnen wi niet gheleisten. [Middle Dutch]  
 this NEG can we not allow  
 ‘We cannot allow this.’

Since standard Dutch lost this negative clitic around 1600 AD, we will not digress on this issue any further, but simply assume that Dutch *niet* ‘not’ resembles *nie(t)* in West-Flemish and Middle Dutch in that it occupies the specifier position of the functional projection NegP. That Dutch *niet* is not a head can further be supported by the fact that it can be modified by means of an amplifier: cf. *beslist/zeker niet* ‘absolutely/certainly not’.

## II. *Neg-movement*

Subsection I has argued that the negative adverb *niet* ‘not’ is located in the specifier position of NegP if it is used to express sentential negation. If correct, the overall structure of negative clauses is as given in (94), in which we omitted the higher functional projections CP and TP and in which ADV stands for modal adverbs such as *waarschijnlijk* ‘probably’.

- (94) ... ADV [<sub>NEGP</sub> ... Neg [<sub>LD</sub> ... V ...]]

This subsection will adopt the structure in (94) as its point of departure and argue that negative noun phrases like *niets* ‘nothing’, *niemand* ‘nobody’, and *geen N* ‘no N’ obligatorily move into the specifier of NegP as well, in order to enable negation to take scope over the proposition expressed by the lexical domain of the verb.

### A. *The specifier of NegP must be filled by a negative phrase*

It is relatively difficult to show on the basis of nominal arguments that the specifier of NegP must be filled by a negative phrase: examples such as (95) are compatible with the claim that the negative form *niemand/niets* must move into the specifier of NegP, but since the simplified representations in the (b)-examples show that Neg-movement does not cross any phonetically realized material, these examples do not provide conclusive evidence for movement.

- (95) a. Vandaag heeft waarschijnlijk niemand dat boek gelezen.  
 today has probably nobody that book read  
 ‘Probably, nobody has read that book today.’  
 a’. Vandaag heeft waarschijnlijk [<sub>NEGP</sub> niemand; Neg [<sub>LD</sub> *t*<sub>i</sub> dat boek gelezen]].  
 b. Jan heeft waarschijnlijk niets gelezen.  
 Jan has probably nothing read  
 ‘Jan probably hasn’t read anything.’  
 b’. Jan heeft waarschijnlijk [<sub>NEGP</sub> niets<sub>i</sub> Neg [<sub>LD</sub> *t*<sub>i</sub> gelezen]].

Examples with manner adverbs provide at least weak evidence for Neg-movement of direct objects. Example (96a) shows that direct objects can normally either precede or follow manner adverbs, where we leave the syntactic and semantic differences between the two orders open for the moment. Example (96b) shows that negative phrases such as *niets* ‘nothing’ normally precede manner adverbs; this would follow if *niets* is obligatorily moved into the specifier of NegP.

- (96) a. Jan heeft waarschijnlijk <het hek> met zorg <het hek> geverfd.  
 Jan has probably the gate with care painted  
 ‘Jan has probably painted the gate with care.’  
 b. Jan heeft waarschijnlijk [<sub>NEGP</sub> <niets> [<sub>LD</sub> met zorg <?”niets> geverfd]].  
 Jan has probably nothing with care painted  
 ‘Jan probably hasn’t painted anything with care.’

Prepositional objects such as *naar Peter* in (97) also provide weak evidence for Neg-movement. While example (97a) shows that prepositional objects can either precede or follow manner adverbs, where we leave the differences between the two orders open for the moment, (97b) shows that the negative prepositional objects such as *naar niemand* ‘to nobody’ normally precede manner adverbs; this would again follow if *naar niemand* is moved into the specifier of NegP. Since we assume that the movement of the PP is motivated by the necessity of assigning scope to the negative operator, we must conclude that we are dealing with pied piping in example (97b), due to the fact that Dutch normally does not allow preposition stranding. This seems to be confirmed by the fact illustrated in (97c) that the preposition is obligatory stranded if the complement of the preposition is realized as the negative R-word *nergens*, which can strand prepositions.

- (97) Jan heeft waarschijnlijk ...  
 Jan has probably  
 a. ... <naar Peter> goed <naar Peter> geluisterd.  
 to Peter well listened  
 ‘Jan has probably listened well to Peter.’  
 b. ... [<sub>NEGP</sub> <naar niemand> [<sub>LD</sub> goed <\*”naar niemand> geluisterd]].  
 ... to nobody well listened  
 ‘Jan probably hasn’t listened well to anyone.’  
 c. ... [<sub>NEGP</sub> <nergens> [<sub>LD</sub> goed [<sub>PP</sub> <\*”nergens> naar] geluisterd]].  
 nowhere well to listened  
 ‘Jan probably hasn’t listened well to anything.’

Example (98) provides similar examples with a PP-complement of an adjectival complementive. While example (98a) shows that the PP can either precede or follow the adjectival phrase *erg trots* ‘very proud’, where we leave the difference between the two orders open for the moment, example (98b) shows that the negative prepositional object *op niemand* ‘to nobody’ precedes it; this again follows if *op niemand* is moved into the specifier of NegP. Example (98c) further shows that the preposition is obligatory stranded if the complement of the preposition is realized as the negative R-word *nergens*.

- (98) dat Jan waarschijnlijk ...  
 that Jan probably
- a. ... <op zijn zoon> erg trots <op zijn zoon> is.  
 of his son very proud is  
 ‘that Jan is probably very proud of his son.’
  - b. ... [<sub>NEGP</sub> <op niemand>] [<sub>LD</sub> [<sub>AP</sub> erg trots <\*op niemand>] is]].  
 of his son very proud is  
 ‘that Jan probably isn’t very proud of anyone.’
  - c. ... [<sub>NEGP</sub> <nergens>] [<sub>LD</sub> [<sub>AP</sub> erg trots [<sub>PP</sub> <\*nergens> op]] is]].  
 nowhere very proud of is  
 ‘that Jan probably isn’t very proud of anything.’

The examples provided in this subsection conclusively show that negative phrases are obligatorily moved into the specifier of NegP; the semantic motivation of this is that it enables negation to take scope over the proposition expressed by the lexical domain of the main verb.

*B. Negative phrases can be topicalized*

It is not necessary for the negative phrase to appear in the specifier of NegP in the surface structure of the clause: the examples in (99) show that negative phrases may also occur in clause-initial position. That topicalization of negative phrases is possible follows if we assume that topicalization does not take place in one fell swoop, but involves an intermediate movement step into the specifier position of NegP, as a result of which this specifier is filled by a trace of the topicalized negative phrase: [<sub>CP</sub> XP [<sub>+Neg</sub>] C [<sub>TP</sub>.. T ... [<sub>NegP</sub> t<sub>XP</sub> Neg [<sub>LD</sub> ... V ...]]]]. We refer the reader to Haegeman (1995:137-8) for an alternative proposal motivated by West-Flemish data that cannot be replicated for Standard Dutch.

- (99) a. Niemand heeft het boek gelezen. [subject]  
 nobody has the book read  
 ‘Nobody has read the book.’
- b. Niets heeft Jan gelezen. [direct object]  
 nothing has Jan read  
 ‘Jan hasn’t read anything.’
- c. Naar niemand heeft Jan goed geluisterd. [prepositional object]  
 to nobody has Jan well listened  
 ‘Jan hasn’t listened well to anybody.’
- d. Op niemand is Jan erg trots. [PP-complement of adjective]  
 of nobody is Jan very proud  
 ‘Jan isn’t very proud of anybody.’



### C. Negative phrases cannot be extraposed

Examples (100a) shows that while prepositional objects can normally be extraposed, this is impossible if the nominal complement of the PP is negative. Example (100b) illustrates the same for a PP-complement of an adjectival complementive. The unacceptability of extraposition follows naturally if we adopt the hypothesis from Chapter 12 that extraposition is not derived by movement of the extraposed phrase; this makes it quite implausible that the specifier of NegP would be filled by a trace of the extraposed phrase.

- (100) a. Jan heeft waarschijnlijk goed geluisterd naar Peter/\*niemand.  
 Jan has probably well listened to Peter/nobody  
 ‘Jan has probably listened well to Peter.’
- b. dat Jan waarschijnlijk erg trots is op zijn zoon/\*niemand.  
 that Jan probably very proud is of his son/nobody  
 ‘that Jan is probably very proud of his son.’

### D. Negative phrases that are not in the specifier of NegP

The discussion so far has shown that negative clauses contain a NegP the specifier of which must be filled by a negative phrase. It should be noted again, however, that negative phrases only move into the specifier of NegP if they express sentence negation; if Neg-movement does not apply, we are dealing with constituent negation. The constituent negation reading does not give rise to a very felicitous result for most of the examples given in the previous subsections, but it is possible in (101), in which the two examples form a minimal pair. Example (101a), in which the PP-complement occupies its original postadjectival position, involves constituent negation; this example literally means that Jan will be satisfied if he has got nothing, but is normally used in an idiomatic sense to express that Jan has virtually no requirements. This interpretation contrasts sharply with the one associated with example (101b), in which Neg-movement has applied, and which expresses that Jan will not be satisfied, no matter what he obtains. For completeness’ sake, note that PP-over-V in *dat Jan tevreden is met niets* is compatible with the constituent negation reading in (101a), but not with the sentential negation reading in (101b).

- (101) a. dat Jan [<sub>LD</sub> [<sub>AP</sub> tevreden [<sub>PP</sub> met niets]] is].  
 that Jan satisfied with nothing is  
 ‘that Jan is satisfied with very little.’
- b. dat Jan [<sub>NEGP</sub> [<sub>PP</sub> met niets]<sub>i</sub> [<sub>LD</sub> [<sub>AP</sub> tevreden *t*<sub>i</sub>] is]].  
 that Jan with nothing satisfied is  
 ‘that Jan isn’t satisfied with anything.’

Other cases in which negative phrases do not move into the specifier of NegP are denials of the type in (102b), in which a noun phrase is simply replaced by a negative expression. Haegeman (1995) considers instances like the negative counterpart of the echo-question in (102b’), noting neither the negative phrase nor the *wh*-phrase takes scope over the clause.

- (102) a. Jan is erg trots op zijn medaille. [speaker A]  
 Jan is very proud of his medal
- b. Nee hoor, Jan is erg trots op NIETS. [speaker B]  
 no hear Jan is very proud of nothing
- b'. Jan is erg trots op WAT? [speaker B]  
 Jan is very proud of what

### III. A note on negative polarity items

The previous subsections have shown that the specifier of NegP must be filled by either the negative adverb *niet* or a negative phrase. We may therefore expect that certain negative clauses can be expressed in two different ways. That this is possible in principle is clear from the fact that the Dutch example in (103a) can be translated into English by means of the negative adverb *not* followed by the negative polarity item (NPI) *anything*. Example (103b) shows, however, that the English strategy is not available in Dutch.

- (103) a. dat Jan [<sub>NEGP</sub> niets<sub>i</sub> Neg [<sub>LD</sub> t<sub>i</sub> zegt]].  
 that Jan nothing says  
 'that Jan doesn't say anything.'
- b. \*dat Jan [<sub>NEGP</sub> niet Neg [<sub>LD</sub> ook maar iets zegt]].  
 that Jan not anything says

That Neg-movement is preferred to the use of *niet* + NPI is a rather persistent property of Dutch: the (a)- and (b)-examples in (104) illustrate this for, respectively, a prepositional object and a PP-complement of a complementive adjective.

- (104) a. dat Jan [<sub>NEGP</sub> [<sub>PP</sub> op niemand]<sub>i</sub> Neg [<sub>LD</sub> t<sub>i</sub> wacht]].  
 that Jan for nobody waits  
 'that Jan won't wait for anybody.'
- a'. \*dat Jan [<sub>NEGP</sub> niet [<sub>LD</sub> [<sub>PP</sub> op ook maar iemand] wacht]].  
 that Jan not for anybody waits
- b. dat Jan [<sub>NEGP</sub> [<sub>PP</sub> op niemand]<sub>i</sub> [[<sub>erg</sub> gesteld t<sub>i</sub>] is]].  
 that Jan of nobody very fond is  
 'that Jan isn't very fond of anybody.'
- b'. \*dat Jan [<sub>NEGP</sub> niet [<sub>LD</sub> [<sub>AP</sub> erg gesteld [<sub>PP</sub> op ook maar iemand]] is]].  
 that Jan not very fond of anybody is

The NPI *ook maar iets/iemand* 'anything/anybody' can only be used if the clause contains some other negative phrase or if negation is located in a higher clause, as in the examples in (105). In such examples NPI's are not involved in the expression of sentence negation, however; they are simply licensed by negation as emphatic forms of the existential pronouns *iets/iemand* 'something/somebody'

- (105) a. Niemand heeft ook maar iets gezien.  
 nobody has anything seen  
 'Nobody has seen anything.'
- b. Ik denk niet [dat Jan ook maar iets gezien heeft].  
 I think not that Jan anything seen has  
 'I don't think that Jan has seen anything.'

This section has shown that Dutch strongly prefers Neg-movement to the semantically equivalent construction with a negative adverb followed by an NPI. In this respect Dutch differs conspicuously from English, in which the movement strategy is not found. This is of course related to the fact that English has a more rigid word order than Dutch; see Broekhuis & Klooster (2010) for more discussion and an account of this difference framed in terms of optimality theory.

#### IV. Neg-movement is A'-movement

The previous subsections have argued that Dutch has a functional projection NegP external to the lexical domain of the verb, which follows modal adverbs such as *waarschijnlijk* 'probably'. If correct, the overall structure of negative clauses is as given in (94), in which ADV indicates the position of the modal adverbs. Because Neg-movement is not restricted to noun phrases, but may also apply to PPs, it cannot be an instance of A-movement but should involve A'-movement, which is further supported by the fact that Neg-movement evidently has a semantic motivation: it is needed in order to assign clausal scope to negation.

(106) [CP ... C [TP ... T [... ADV [<sub>NEGP</sub> ... Neg [<sub>VP</sub> ... *v* [<sub>VP</sub> ... V ...]]]]]]

The claim that Neg-movement is A'-movement makes an interesting prediction about the position of nominal arguments in view of Chomsky's (1986) improper movement restriction. This restriction prohibits A-movement of a phrase XP after it has been A'-moved: Neg-movement of a nominal argument should therefore block nominal argument shift across modal adverbs such as *waarschijnlijk* 'probably', which Section 13.2 has shown to be an instance of A-movement. The examples in (107), which are repeated from Section N8.1.3.1, sub IVC, show that this expectation is indeed borne out. The negative pronoun *niemand* cannot undergo nominal argument shift from the specifier position of NegP, which follows the modal adverb, into the specifier positions of the lexical heads assigning accusative and nominative case, which precede the modal adverb: see the representations in example (40) from Section 13.2, sub IA.

- (107) a. dat Jan <\*niemand> waarschijnlijk <niemand> uitnodigt.  
           that Jan nobody probably invites  
       b. dat <<sup>??</sup>niemand> waarschijnlijk <niemand> dat boek gelezen heeft.  
           that nobody probably that book read has

The judgments on these examples seem confirmed by a Google search (6/11/2015). We checked our judgments on (107a) by means of the search string [*dat PRON niemand waarschijnlijk*], in which PRON stands for a set of subject pronouns; this string does not occur at all. We checked out judgments on (107b) by means of the search strings [*dat waarschijnlijk niemand*] and [*dat niemand waarschijnlijk*]; the former string resulted in 191 hits and is therefore much more frequent than the second string, which resulted in no more than 32 hits, some of which struck us as quite marked. Observe that the acceptability contrasts indicated in (107) cannot be accounted for by claiming that negative noun phrases must occur in the specifier position of NegP, because Subsection IIB has shown that they can easily be moved into clause-initial position; the relevant examples are repeated in (108).

- (108) a. Niemand heeft het boek gelezen. [subject]  
 nobody has the book read  
 ‘Nobody has read the book.’
- b. Niets heeft Jan gelezen. [direct object]  
 nothing has Jan read  
 ‘Jan hasn’t read anything.’

If the unacceptable orders in (107) are indeed ruled out by the improper movement restriction, the acceptability of the examples in (108) need not surprise us because topicalization is clearly a case of A'-movement. The contrast between nominal argument shift and topicalization of negative noun phrases thus supports the claim that Neg-movement is A'-movement (but see Section N8.1.3.1, sub IVC, for an alternative account for the impossibility of nominal argument shift in (107)).

#### V. *The interaction of Neg movement and nominal argument shift*

Subsection IV has shown that negative subjects cannot be moved into the regular subject position by nominal argument shift. The fact that negative phrases follow the modal adverbs when they are part of the middle field, while the target positions of nominal argument shift precede the modal adverbs, raises the question as to whether negative subjects can be crossed by other nominal arguments. The answer is negative, as is clear from the fact illustrated in (109a) that the direct object *het boek* cannot shift across the negative subject *niemand* (under a non-contrastive intonation pattern of the clause), and that the acceptable order is actually ambiguous in that the direct object can be interpreted as either part of the new-information focus or the presupposition of the clause. For completeness' sake, we have added example (109b) to show that the negative subject cannot easily be pushed up into the regular subject position by the direct object.

- (109) a. dat <\*het boek> waarschijnlijk niemand <het boek> gekocht heeft.  
 that the book probably nobody the book bought has  
 ‘that probably nobody has bought the book.’
- b. ??dat niemand het boek waarschijnlijk gekocht heeft.  
 that nobody the book probably bought has

The examples in (110) show that the same pattern arises for negative subjects and pronominal indirect objects; as indirect objects and subjects are frequently both [+HUMAN], we use a strong object pronoun in order to avoid processing problems.

- (110) a. dat <\*hem> waarschijnlijk niemand <hem> hulp aangeboden heeft.  
 that him probably nobody him help prt.-offered has  
 ‘that probably nobody has offered him help.’
- b. ??dat niemand hem waarschijnlijk hulp aangeboden heeft.  
 that nobody him probably help prt.-offered has

The examples above have shown that negative subjects normally block object shift (although it is perhaps marginally possible for the object to push the negative subject up into the regular object position in violation of the improper movement restriction). This shows that ordering restriction (111) also applies in negative clauses.

- (111) Ordering restriction on nominal argument shift in Standard Dutch: nominal argument shift does not affect the unmarked order of the nominal arguments (agent > goal > theme).

We want to conclude by repeating that the judgments in (109a) and (110a) only hold if the sentences are pronounced with a neutral intonation pattern. The orders marked with a star become acceptable if the objects are given contrastive accent: *dat HET BOEK waarschijnlijk niemand gekocht heeft* and *dat HEM waarschijnlijk niemand hulp aangeboden heeft* are both perfectly acceptable. However, argument inversion in such examples is not the result of A-movement (nominal argument shift) but of A'-movement (topic or focus movement). We refer the reader to Section 13.3.2 for a discussion of the latter type of movement.

### 13.3.2. Contrastive focus and topic movement

This section discusses focus and topic movement, which are illustrated in (112a) and (112b), respectively. The fact that the movements in (112) involve a PP, which moreover functions as a subpart of a clausal constituent, immediately shows that we are dealing with A'-movement. We will represent the lexical domain of the verb as [LD ... V ...] instead of [<sub>VP</sub> ... v [<sub>VP</sub> ... V ...]], and ignore traces of subjects if they are not directly relevant for the discussion; cf. the introduction to Section 13.3.

- (112) a. dat Marie [<sub>FocP</sub> [op *PETER*]<sub>i</sub> Foc [LD [<sub>AP</sub> erg dol *t<sub>i</sub>*] is]].  
 that Marie of Peter very fond is  
 'that Marie is very fond of Peter.'
- b. Ik weet niet wat Marie van Jan vindt, maar ik weet wel ...  
 I know not what Marie of Jan considers, but I know AFF  
 dat ze [<sub>TopP</sub> [op *Peter*]<sub>i</sub> Top [LD [<sub>AP</sub> erg dol *t<sub>i</sub>*] is]].  
 that she of Peter very fond is  
 'I don't know how Marie feels about Jan but I do know she's very fond of Peter.'

The contrastive phrases in (112) are characterized phonetically by a specific accent involving a high pitch followed by a sudden drop in pitch. The two cases differ in that the contrastive focus accent, which is sometimes called A-accent, concludes after the fall in pitch, while the contrastive topic accent, which is sometimes called B-accent, has an additional rise in pitch; cf. Jackendoff (1972: section 6.7), Büring (2007), and Neeleman & Van de Koot (2008). The development of the two pitch accents is represented in (113) by means of lines: in the examples words with an A-accent will be indicated by means of small caps in italics, while words with a B-accent will not be in small caps but will be doubly underlined as well as italicized; cf. (112).

- (113) ... dat Marie op Peter erg dol is
- 

Semantically speaking, contrastive accent evokes a set of alternative propositions. A common intuition is that contrastive focus involves “some kind of contrast between the Focus constituent and alternative pieces of information which may be

explicitly presented or presupposed” (Dik 1997:332). This can be formally represented by assuming that focus adds an additional semantic value (henceforth: focus value) to the regular semantic value (henceforth: ordinary value) of a clause; cf. Rooth (1997). So, while the ordinary value of the sentence *Jan bezoekt Marie* ‘Jan is visiting Marie’ is simply the proposition given in (114a&b), the added focus values are sets of proposition, as indicated in the primed examples, in which the value of the variables  $x$  and  $y$  are taken from the set of (contextually defined) individuals  $E$ .

- (114) a. [Jan bezoekt [<sub>FOCUS</sub> Marie]]<sup>o</sup> = VISIT(j,m) [ordinary value]  
 a'. [Jan bezoekt [<sub>FOCUS</sub> Marie]]<sup>F</sup> = {VISIT(j,x) |  $x \in E$ } [focus value]  
 b. [[<sub>FOCUS</sub> Jan] bezoekt Marie]<sup>o</sup> = VISIT(j,m) [ordinary value]  
 b'. [[<sub>FOCUS</sub> Jan] bezoekt Marie]<sup>F</sup> = {VISIT(y,m) |  $y \in E$ } [focus value]

The function of non-contrastive (new information) focus is that the speaker fills in an information gap on the part of the addressee by adding or selecting a proposition to or from the focus value; the speaker crucially does not intend to imply anything for the alternative propositions from the focus value. By using the A-accent on the other hand, the speaker implies that the ordinary value of the clause is counter-presuppositional. An utterance such as *Jan bezoekt MARIE* then opposes the ordinary value of the clause in (114a) to other propositions from the focus value in (114a') that the speaker assumes to be considered true by the addressee, that is, the speaker implies that Jan did *not* visit at least one individual from  $E$ ; see also Neeleman & Vermeulen (2012). It should be noted that the nature of the counter-presuppositional relation can be further specified by focus particles like *alleen* ‘only’ and *ook* ‘too’; we will return to this in Subsection IC. By using the contrastive B-accent, the speaker implies that there is at least one other potential discourse topic that could have been addressed. For instance, the plurality of the finite verb in question (115a) implies that the set of contextually defined individuals  $E$  contains at least two persons who are expected to be invited for the party. The answer in (115b) does not provide an answer to the question but asserts something about one of the individuals from  $E$ ; cf. Buring (2007), Neeleman & Van de Koot (2008) and Neeleman & Vermeulen (2012).

- (115) a. Wie zijn er uitgenodigd voor het feest? [question]  
 who are there invited for the party  
 ‘Who are invited to the party?’  
 b. Geen idee. Ik weet alleen dat Peter niet kan komen. [answer]  
 no idea I know only that Peter not can come  
 ‘No idea. I only know that Peter cannot come.’

The examples in (112) have already shown that contrastive foci and topics are characterized syntactically by the fact that they can be displaced. This property will be investigated in more detail in the following subsections. Subsection I starts with a discussion of focus movement, which is followed by a discussion of topic movement in Subsection II. The investigation of focus and topic movement is relatively recent and it is therefore not surprising that there are still a large number of controversial issues, some of which will be discussed in Subsection III.

### I. Focus movement

The direct objects in answers such as (116b&c) are assigned regular sentence accent (indicated by small caps) and are therefore part of the new-information focus. They can nevertheless be construed as contrastive foci in the sense that they exclude values of the variable *x* other than Marie. It should be noted, however, that in these cases the contrastive interpretations are entirely pragmatic in nature, as Grice's °cooperative principle requires the answers in (116) to be complete; cf. Neeleman & Vermeulen (2012).

- (116) a. Wie heeft Jan/hij bezocht? [question: ?x(Jan/he has visited x)]  
 who has Jan/he visited  
 'Who has Jan/he visited?'
- b. Hij heeft een VRIENDIN bezocht: Marie. [answer]  
 he has a friend visited Marie  
 'He has visited a lady friend: Marie.'
- c. Jan heeft MARIE bezocht. [answer]  
 Jan has Marie visited  
 'Jan has visited Marie.'

The cases of contrastive foci that will be discussed in this subsection are different in that they are characterized as contrastive by the phonetic property of carrying a contrastive A-accent and the syntactic property that they can be moved leftward by focus movement. Subsection A starts by discussing the landing site of focus movement, Subsection B will argue that focus movement is A'-movement, and Subsection C will conclude by arguing that focus movement is obligatory, just like other semantically motivated movements.

#### A The landing site of focus movement

This subsection discusses the landing site of focus movement. Following the line of research in Rizzi (1996) and Haegeman (1995), one option would be to postulate a focus phrase (FocP) in the middle field of the clause, the specifier of which is a designated landing site for focus movement. Neeleman & Van de Koot (2008) assume that focus movement is motivated by the need to assign scope to the focus phrase or, in their formulation, to distinguish contrastive foci from the backgrounds against which they are evaluated; see Barbiers (2010) for an alternative proposal. Since we have seen that contrastive foci evoke a set of alternative propositions, we may safely conclude that the background *at least* contains the lexical domain of the main verb: this entails that FocP is part of the verb's functional domain.

- (117) ... [FocP XP<sub>i</sub> Foc [ ... [LD ... t<sub>i</sub> ...]]]

Neeleman & Van de Koot argue against hypothesis (117), in as far as it postulates a designated target position for focus movement, and claim that focus movement can target *any* position from which the contrastively focused phrase may take scope over its background. The advantage of their proposal is that we can easily account for examples such as (118) by saying that the word order difference between the two examples reflects a scopal difference between the focused phrase and the modal



adverb *waarschijnlijk* ‘probably’: the adverb is in the scope of the focus in (118a), but not in (118b).

- (118) a. dat ze [op *PETER*]<sub>i</sub> waarschijnlijk [<sub>LD</sub> [<sub>AP</sub> erg dol *t*<sub>i</sub>] is].  
 that she of Peter probably very fond is  
 ‘that she is probably very fond of *PETER*.’  
 b. dat ze waarschijnlijk [op *PETER*]<sub>i</sub> [<sub>LD</sub> [<sub>AP</sub> erg dol *t*<sub>i</sub>] is].  
 that she probably of Peter very fond is  
 ‘that she is probably very fond of *PETER*.’

A potential problem for the hypothesis that the contrastively focused phrase can target any position from which it may scope over the lexical domain of the clause is that it seems to overgenerate. The examples in (119b&c), for instance, show that the target position of focus movement cannot follow negation or precede a weak subject pronoun in the regular subject position.

- (119) a. dat ze [op *PETER*]<sub>i</sub> niet [<sub>LD</sub> [<sub>AP</sub> erg dol *t*<sub>i</sub>] is].  
 that she of Peter not very fond is  
 ‘that she probably isn’t very fond of *PETER*.’  
 b. \*dat ze niet [op *PETER*]<sub>i</sub> [<sub>LD</sub> [<sub>AP</sub> erg dol *t*<sub>i</sub>] is].  
 that she not of Peter very fond is  
 c. \*dat [op *PETER*]<sub>i</sub> ze niet [<sub>LD</sub> [<sub>AP</sub> erg dol *t*<sub>i</sub>] is].  
 that of Peter she not very fond is

The schematic representation in (120a) summarizes the positions in which the contrastively focused PP *op Peter* can or cannot be found. On the assumption that focus movement targets the specifier position of a FocP, we can account for this in at least two ways. One option is to adopt the representation in (120b), according to which there are *two* FocPs, one relatively high and one relatively low in the middle field of the clause; cf. Belletti (2004), Aboh (2007), and Zubizarreta (2010). Another option is that there is just *a single* FocP but that the modal adverb can be placed either above or below FocP depending on its scope relative to the contrastive focus, as in (120b’).

- (120) a. dat <\*PP<sub>i</sub>> hij <PP<sub>i</sub>> waarschijnlijk <PP<sub>i</sub>> niet <\*PP<sub>i</sub>> [<sub>LD</sub> [<sub>AP</sub> erg dol *t*<sub>i</sub>] is].  
 b. dat hij .. [<sub>FocP</sub> .. Foc [<sub>LD</sub> .. waarschijnlijk [<sub>FocP</sub> .. Foc [<sub>NegP</sub> .. Neg [<sub>LD</sub> ...]]]]]  
 b’. dat hij <waarschijnlijk> [<sub>FocP</sub> .. Foc [<sub>LD</sub> .. <waarschijnlijk> [<sub>NegP</sub> .. Neg [<sub>LD</sub> ...]]]]

Since the debate on the landing site of focus movement is just in its initial stage, we will not evaluate the three proposals any further, but simply assume for concreteness’ sake that focus movement targets the specifier of FocP.

### B. Focus movement is A’-movement

This subsection reviews a number of arguments for assuming that focus movement is A’-movement. A first, and conclusive, argument is that focus movement can affect non-nominal categories. It has also been argued that focus movement may violate certain word order restrictions that constrain A-movement, but we will see that there are certain difficulties with this argument. A third argument found in the literature is that focus movement is not clause-bound.

1. *Categorial restrictions*

A-movement is restricted to nominal categories. The fact illustrated again in (121b) that focus movement may also affect PPs is therefore sufficient for concluding that we are dealing with A'-movement. Example (121c) further supports this conclusion by providing an example in which an adjectival complementive has undergone focus movement.

- (121) a. dat Jan waarschijnlijk [het *BOEK*]<sub>i</sub> niet *t*<sub>i</sub> wil kopen.  
 that Jan probably the book not wants buy  
 'that Jan probably doesn't want to buy the BOOK.'
- b. dat Jan waarschijnlijk [op *VADER*]<sub>i</sub> niet *t*<sub>i</sub> wil wachten.  
 that Jan probably for father not wants wait  
 'that Jan probably doesn't want to wait for FATHER.'
- c. dat Jan deze zaak waarschijnlijk [*ZO* belangrijk]<sub>i</sub> niet *t*<sub>i</sub> vindt.  
 that Jan this case probably that important not considers  
 'that Jan probably doesn't consider this case THAT important.'

The conclusion that focus movement is A'-movement is in line with the conclusion that focus movement may target a position to the right of the modal adverbs because Section 13.2 has shown that nominal argument shift targets a position to the left of the modal adverbs. This contrast can be highlighted by the VP-topicalization constructions in (122), which show that the direct object can only be stranded in a position after the clause adverbials if it is contrastively focused.

- (122) a. [<sub>VP</sub> *t*<sub>i</sub> Kopen] wil Jan <het boek<sub>i</sub>> waarschijnlijk <\*het boek<sub>i</sub>> *t*<sub>VP</sub>.  
 buy wants Jan the book probably
- b. [<sub>VP</sub> *t*<sub>i</sub> Kopen] wil Jan waarschijnlijk het *BOEK*<sub>i</sub> *t*<sub>VP</sub>.  
 buy wants Jan probably the book

It can also be illustrated quite nicely by means of the placement of strong (phonetically non-reduced) referential personal pronouns like *zij* 'she' en *haar* 'her'; such pronouns may only occur after the modal adverbs if they carry an A-accent.

- (123) a. dat <*zij*/*ZIJ*> waarschijnlijk <*ZIJ*/\**zij*> het boek gekocht heeft.  
 that she/SHE probably the book bought has  
 'that she/SHE probably has bought the book'
- b. dat Jan <*haar*/*HAAR*> waarschijnlijk <*HAAR*/\**haar*> wil helpen.  
 that Jan her/HER probably wants help  
 'that Jan probably wants to help her/HER.'

Furthermore, that nominal argument shift and focus movement target different landing sites is highlighted by the fact that [-HUMAN] referential personal pronouns can never occur after the modal adverbs, for the simple reason that they are obligatorily reduced phonetically; in order to contrastively focus an inanimate entity, the demonstrative *deze/die* 'this/that' is needed.

- (124) a. dat hij <de AUTO> waarschijnlijk <de AUTO> gekocht heeft.  
 that he the car probably bought has  
 ‘that he probably has bought the car.’
- b. dat hij <’m/DIE> waarschijnlijk <DIE/\*HEM/\*’m> gekocht heeft.  
 that he him/DEM probably bought has  
 ‘that he probably has bought *THAT ONE*.’

## 2. *Word order*

Another argument in favor of an A'-movement analysis of focus movement has to do with word order. Section 13.2, sub IC, has shown that nominal argument shift cannot affect the unmarked order of nominal arguments (agent > goal > theme) in Dutch. Neeleman & Van de Koot (2008), Van de Koot (2009) as well as Neeleman & Vermeulen (2012) claim that focus movement *is* able to change the order of nominal arguments, as illustrated in (125), and that this supports the claim that we are dealing with A'-movement.

- (125) a. %Ik geloof [dat DIT BOEK<sub>i</sub> Jan Marie t<sub>i</sub> gegeven heeft].  
 I believe that this book Jan Marie given has
- b. %Ik geloof [dat Jan DIT BOEK<sub>i</sub> Marie t<sub>i</sub> gegeven heeft].  
 I believe that Jan this book Marie given has
- c. Ik geloof [dat Jan Marie DIT BOEK gegeven heeft].  
 I believe that Jan Marie this book given has  
 ‘I believe that Jan has given Marie this book.’

The argument is not entirely convincing; the fact that this type of order preservation does not hold for German nominal argument shift shows that it is not a defining property of nominal argument shift; cf. Section 13.2, sub IC. Furthermore, the judgments given by Neeleman and his collaborators are controversial, as some speakers of Dutch (including the authors of this work) reject the examples in (125a&b) with the indicated intonation pattern; see also Neeleman & Van de Koot (2008:fn.2) and Van de Koot (2009:fn.4). A simpler example –which is likewise rejected by some of our informants– is given in (126). In our view, the unclear acceptability status of (125a&b) and (126a) makes it impossible to draw any firm conclusion from them; in fact, it remains to be seen whether these examples should be considered part of the standard variety of Dutch, but we will leave this issue for future research.

- (126) a. %Ik geloof [dat DIT BOEK<sub>i</sub> Jan t<sub>i</sub> gelezen heeft].  
 I believe that this book Jan read has
- b. Ik geloof [dat Jan DIT BOEK<sub>i</sub> gelezen heeft].  
 I believe that Jan this book read has  
 ‘I believe that Jan has read *THIS BOOK*.’

In order to avoid confusion, we should note that the examples marked with % become acceptable if the contrastively accented phrases are given a B-accent, in which case we are dealing with a contrastive topic; Subsection II will provide more data showing that topic movement may indeed affect the unmarked order of nominal arguments under certain conditions.

Example (127a) shows that focus movement is able to change the unmarked order of nominal and prepositional objects: while prepositional indirect objects normally follow direct objects, focus movement of the former can easily cross the latter. It should be noted, however, that this requires the direct object to follow the modal adverb: the examples in (127b&c) show that object shift of *het boek* has a degrading effect on focus movement regardless of whether the focused phrase precedes or follows the modal adverb; we added the adverb *niet* to (127c) to make focus movement visible. Observe that (127b) becomes fully acceptable if the PP is assigned a B-accent, which shows that topic movement may cross a shifted object.

- (127) a. dat Jan <aan *ELS*> waarschijnlijk <aan *ELS*> het boek zal geven.  
 that Jan to Els probably the book will give  
 ‘that Jan will probably give the book to Els.’
- b. ??dat Jan aan *ELS* het boek waarschijnlijk zal geven.  
 that Jan to Els the book probably will give  
 ‘that Jan will probably give the book to *ELS*.’
- c. dat Jan het boek waarschijnlijk <??aan *ELS*> niet <aan *ELS*> zal geven.  
 that Jan the book probably to Els not will give  
 ‘that Jan probably will not give the book to *ELS*.’

This subsection has shown that the claim that focus movement is able to change the unmarked order of nominal arguments in Standard Dutch is controversial; whether this property could be used as an argument in favor of the claim that focus movement is A'-movement is not clear either, as order preservation seems to be an accidental property of nominal argument shift in Dutch.

### 3. Focus movement is not clause-bound

A'-movement differs from A-movement in that it allows extraction from finite clauses under certain conditions. Neeleman (1994a/1994b) and Barbiers (1999/2002) have shown that this also holds for focus movement: the examples in (128) illustrate that foci can target a focus position in the middle field of a matrix clause. The percentage signs are used to indicate that this type of long focus movement is normally not found in writing but can be encountered in colloquial speech; cf. Zwart (1993:200).

- (128) a. %Ik had [in de *TUIN*]<sub>i</sub> gedacht [dat het feest *t<sub>i</sub>* zou zijn].  
 I had in the garden thought that the party would be  
 ‘I had thought that the party would be in the *GARDEN*.’
- b. %Ik had [een *BOEK*]<sub>i</sub> gedacht [dat Jan *t<sub>i</sub>* zou kopen].  
 I had a book thought that Jan would buy  
 ‘I had thought that Jan would buy a *BOOK*.’

That the landing site of the foci is external to the embedded clause is clear from the fact that the foci precede the clause-final main verb of the matrix clause. Because the examples in (129) show that embedded topicalization is impossible in Dutch (cf. Section 11.3.3, sub II), it is even impossible for foci to follow the verbs in clause-final position.

- (129) a. \*Ik had gedacht [[in de *TUIN*]<sub>i</sub> dat het feest *t*<sub>1</sub> zou zijn].  
 I had thought in the garden that the party would be  
 b. \*Ik had gedacht [[een *BOEK*]<sub>i</sub> dat Jan *t*<sub>1</sub> zou kopen].  
 I had thought a book that John would buy

Although examples such (128) may be objectionable to certain speakers, the sharp contrast with the examples in (129) show that they are at least marginally possible in standard Dutch. This conclusion is also supported by the fact that the examples in (128) are clearly much better than the corresponding examples in (130) with the factive verb *betreuren* 'to regret'. This contrast shows that long focus movement is only possible in specific bridge contexts.

- (130) a. \*Ik had [in de *TUIN*]<sub>i</sub> betreurd [dat het feest *t*<sub>1</sub> zou zijn].  
 I had in the garden regretted that the party would be  
 b. \*Ik had [een *BOEK*]<sub>i</sub> betreurd [dat Jan *t*<sub>1</sub> zou kopen].  
 I had a book regretted that John would buy

There are reasons for assuming that long focus movement is like long *wh*-movement in that it has to pass through the initial position of the embedded clause. A weakish argument in favor of this claim is that the direct object *een boek* 'a book' in (128) can easily cross the subject, as this is a well-established property of A'-movements that target the clause-initial position. A stronger argument is that long focus movement cannot co-occur with long *wh*-movement, as is illustrated by the examples in (131): the examples in (131b&c) first show that *wh*-phrases and foci can be extracted from the embedded clause in (131a), while (131d) shows that they cannot be extracted simultaneously. This would follow immediately if long movement must proceed via the clause-initial position of the embedded clause: long *wh*-movement would then block long focus movement (or vice versa) because this position can be filled by a single (trace of a) constituent only; see Barbiers (2002) for a slightly different account.

- (131) a. Ik had gedacht [dat Jan morgen in de tuin zou werken].  
 I had thought that Jan tomorrow in the garden would work  
 'I had thought that Jan would work in the garden tomorrow.'  
 b. Waar<sub>i</sub> had jij gedacht [dat Jan morgen *t*<sub>1</sub> zou werken]?  
 where had you thought that Jan tomorrow would work  
 'Where had you thought that Jan would work tomorrow?'  
 c. %Ik had *MORGEN*<sub>j</sub> gedacht [dat Jan *t*<sub>j</sub> in de tuin zou werken].  
 I had tomorrow thought that Jan in the garden would work  
 'I had thought that Jan would work in the garden *TOMORROW*.'  
 d. \*Waar<sub>i</sub> had jij *MORGEN*<sub>j</sub> gedacht [dat Jan *t*<sub>j</sub> *t*<sub>1</sub> zou werken]?  
 where had you tomorrow thought that Jan would work

### C. Is focus movement obligatory?

There is good reason for assuming that A'-movement is obligatory because it is needed to derive structures that can be interpreted by the semantic component of the grammar. Section 11.3.1.1, sub II, argued, for instance, that *wh*-movement in *wh*-questions is obligatory because it derives an operator-variable chain in the sense of

predicate calculus. And Section 13.3.1, sub II, has argued that negation movement is obligatory in order to assign scope to sentence negation. In view of this we may hypothesize that focus movement is needed to assign scope to contrastively focused phrases (unless there is some other means to indicate scope). Languages such as Hungarian, where contrastive foci are obligatorily moved into a position left-adjacent to the finite verb, seem to support this hypothesis; cf. É. Kiss (2002:ch4). Languages such as English, which seem to mark contrastive focus by intonation only, are potential problems for the hypothesis, but since it has been argued that English does have focus movement in at least some constructions (cf. Kayne 1998), it remains to be seen whether languages like English constitute true counterexamples. This subsection argues that focus movement is normally obligatory in Standard Dutch by appealing to constructions featuring focus particles of two types: counter-presuppositional focus particles (*alleen* ‘only’, *ook* ‘also’, etc.) and scalar focus particles (*al* ‘already’, *nog* ‘still’, *maar* ‘just’, etc.).

### 1. Constituents with an A-accent that remain in situ

One potential problem for the hypothesis that focus movement is obligatory in Standard Dutch is that it is sometimes possible to leave constituents with an A-accent in their original position. This is illustrated by the two examples in (132), which suggests that focus movement is optional. Of course, this conclusion is valid only if the two examples are semantically equivalent; this does not seem to be the case, however.

- (132) a. dat Jan [<sub>FocP</sub> [op *PETER*]<sub>i</sub> Foc [<sub>LD</sub> [<sub>AP</sub> erg dol *t<sub>i</sub>*] is]].  
 that Jan of Peter very fond is  
 ‘that Jan is very fond of Peter.’
- b. dat Jan [<sub>AP</sub> erg dol op *PETER*] is.  
 that Jan very fond of Peter is  
 ‘that Jan is very fond of Peter.’

Before showing that the two examples in (132) are not fully equivalent, we will first consider example (133a), which clearly has two readings: contrastive focus may be restricted to the direct object only, in which case the sentence expresses that there are certain other things in the domain of discourse that Jan did *not* read, or it may extend to the verb phrase, in which case the sentence expresses that there were certain things that Jan did *not* do. The examples in (133b&c) show that the two readings evoke different word orders if the negative adverb *niet* is present. The clearest case is (133b), in which contrastive focus is restricted to the moved direct object. Example (133c) is somewhat more complicated, as it again allows two readings, one with contrastive focus on the verb phrase, and one with contrastive focus on the noun phrase. This can be accounted for if we assume that in both cases we are dealing with constituent negation: *Hij heeft niet de roman gelezen, maar het gras gemaaid* ‘he hasn’t read the novel, but mowed the grass’ versus *Hij heeft niet de roman gelezen, maar het gedicht* ‘he didn’t read the novel but the poem’.

- (133) a. dat Jan waarschijnlijk de *ROMAN* gelezen heeft.  
 that Jan probably the novel read has  
 ‘that Jan has probably read the novel.’
- b. dat Jan waarschijnlijk de *ROMAN* niet gelezen heeft.  
 that Jan probably the novel not read has  
 ‘that Jan has probably not read the novel.’
- c. dat Jan waarschijnlijk niet de *ROMAN* gelezen heeft.  
 that Jan probably not the novel read has  
 ‘that Jan has probably not read the novel.’

The crucial thing for our present discussion is that (134a) is more suitable for expressing the restrictive focus reading than (134b). The former case evokes alternative propositions that express that there are persons other than Peter that Jan is very fond of, while (134b) rather expresses that the state of being fond of Peter is not applicable to Jan, as is clear from the fact that it cannot easily be followed by *maar op MARIE* ‘but of Marie’.

- (134) a. dat Jan [op *PETER*]<sub>i</sub> niet [[<sub>AP</sub> erg dol *t<sub>i</sub>*] is], maar (*WEL*) op *MARIE*.  
 that Jan of Peter not very fond is but AFF of Marie  
 ‘that Jan isn’t very fond of Peter, but that he is of Marie.’
- b. dat Jan niet [[<sub>AP</sub> erg dol op *PETER*] is], maar ’m *HAAT*.  
 that Jan not very fond of Peter is but him hates  
 ‘that Jan is not very fond of Peter, but that he hates him.’

For completeness’ sake, note that the PP in (134a) must precede the negative adverb *niet* ‘not’: cf. \**dat Jan niet op PETER erg dol is*. This is expected if it targets the specifier of FocP; see the discussion of (119) and (120).

Although constituents carrying an A-accent can remain in situ, the discussion above suggests that this disfavors the restrictive focus interpretation. Of course, before we can conclude from this that focus movement is obligatory, more should be said about the cases with constituent negation, but one thing is already clear: because *niet* ‘not’ is not located in the specifier of NegP if it expresses constituent negation, its location does not tell us anything about the location of the contrastively focused phrase following it. The next subsection will show that there are reasons for assuming that the negative adverb *niet* functions as a focus particle if it expresses constituent negation and that the contrastively focused phrase following it normally occupies the specifier of FocP.

## 2. Counter-presuppositional focus particles

Focus adds an additional semantic value (henceforth: focus value) to the regular semantic value (henceforth: ordinary value) of a clause, as indicated again in (135) for the sentence *Jan bezoekt Marie* ‘Jan is visiting Marie’.

- (135) a. [Jan bezoekt [<sub>FOCUS</sub> Marie]]<sup>o</sup> = VISIT(j,m) [ordinary value]  
 a'. [Jan bezoekt [<sub>FOCUS</sub> Marie]]<sup>F</sup> = {VISIT(j,x) | x ∈ E} [focus value]  
 b. [[<sub>FOCUS</sub> Jan] bezoekt Marie]<sup>o</sup> = VISIT(j,m) [ordinary value]  
 b'. [[<sub>FOCUS</sub> Jan] bezoekt Marie]<sup>F</sup> = {VISIT(y,m) | y ∈ E} [focus value]



The function of non-contrastive (new information) focus is that the speaker simply fills in an information gap on the part of the addressee by adding/selecting a proposition to/from the focus value of the clause; the speaker does not intend to imply anything for the alternative propositions. Contrastive focus, on the other hand, is counter-presuppositional in the sense that it aims at modifying the subset of propositions  $(P_A)_S$ , that is, the subset of propositions which the speaker presupposes to be considered true by the addressee; see the discussion of (114) in the introduction of this section. The modification can take various forms; we will slightly adapt Dik's (1997) classification by making the four-way distinction in Table 1. The column *expression type* provides the English focus particles prototypically used to express the various subtypes; all subtypes are marked by an A-accent, which is represented by an exclamation mark.

Table 1: Types of counter-presuppositional focus

	$(P_A)_S$	MODIFIED SET $P_S$	EXPRESSION TYPE
CORRECTING	X	Y	not X, but Y!
EXPANDING	X	X and Y	also Y!
RESTRICTING	X and Y	X	only X!
SELECTING	X or Y	X	X!

Correcting focus is the most complex case as correction involves two simultaneous actions: rejection and replacement. The examples in (136) show that the speaker may perform both actions explicitly but that he may also leave one of the two implicit. The act of rejection is performed by means of constituent negation, that is, the focus particle *niet* 'not' in combination with the A-accent, while the A-accent suffices to perform the act of replacement. Note in passing that (136b) is special in that it requires an additional accent on the negative adverb *niet*.

- (136) Jan heeft het boek gekocht.  
 Jan has the book bought  
 'Jan has bought the book.'
- a. Nee, hij heeft niet het *BOEK* gekocht, maar de *PLAAT*. [correction]  
 no he has not the book bought but the record
- b. Nee, hij heeft NIET het *BOEK* gekocht. [rejection]  
 no he has not the book bought
- c. Nee, hij heeft de *PLAAT* gekocht. [replacement]  
 no he has the record bought

Expanding, restricting and selecting focus are illustrated in (137). All cases again involve the A-accent. Expansion and restriction are prototypically expressed by means of the focus particles *ook* 'also' and *alleen* 'only', while selection is like replacement in that it does not involve the use of a focus particle.

- (137) a. Jan heeft het boek gekocht.  
 Jan has the book bought
- a'. Ja, maar hij heeft ook de *PLAAT* gekocht. [expansion]  
 yes but he has also the record bought  
 'Yes, but he has also bought the record.'

- b. Jan heeft het boek en de plaat gekocht.  
 Jan has the book and the record bought
- b'. Nee, hij heeft alleen de *PLAAT* gekocht. [restriction]  
 no he has only the record bought
- c. Heeft Jan het boek of de plaat gekocht?  
 has Jan the book or the record bought
- c'. Jan heeft de *PLAAT* gekocht. [selection]  
 Jan has the record bought

In the primed examples in (137) the focus particles *ook* and *alleen* are associated with nominal arguments but they can also be associated with larger constituents. In the primed examples in (138), for instance, the contrastive focus consists of the verbal projection given within square brackets and the focus particles are therefore associated with this phrase.

- (138) a. Jan heeft het boek gekocht.  
 Jan has the book bought
- a'. Ja, en hij is ook [naar de *BIOSCOOP* geweest]. [expansion]  
 yes and he is also to the cinema been  
 'Yes, and he has also been to the cinema.'
- b. Jan heeft het boek gekocht en is naar de bioscoop geweest.  
 Jan has the book bought and is to the cinema been
- b'. Nee, hij heeft alleen [het *BOEK* gekocht]. [restriction]  
 no he has only the book bought
- c. Heeft Jan het boek gekocht of is hij naar de bioscoop geweest?  
 has Jan the book bought or is he to the cinema been
- c'. Jan heeft [het *BOEK* gekocht]. [selection]  
 Jan has the book bought

More special cases not mentioned by Dik are focus particles like *zelfs* 'even' and *slechts* 'merely', perhaps because they are not necessarily counter-presuppositional. These particles are often akin to the particles *ook* 'also' and *alleen* 'only', but in addition they express a subjective evaluation, extremely high degree, surprise, etc.

- (139) a. Er waren veel mensen aanwezig.  
 there were many people present  
 'Many people were present.'
- b. Ja, ik heb zelfs *PETER* gezien.  
 yes I have even Peter seen  
 'Yes, I have even seen Peter.'

For the discussion below it is crucial to realize that a focus particle and the contrastively focused phrase associated with it may form a constituent. This is clear from the fact that they can occupy the clause-initial position together, as is illustrated in (140) for the relevant examples in (136) and (137). Observe that for unknown reasons it is not readily possible to construct similar cases for the examples in (138): cf. <sup>??</sup>*Alleen het boek gekocht heeft hij*.

- (140) a. Niet het *BOEK* heeft Jan gekocht, maar de *PLAAT*.  
 not the book has Jan bought but the record  
 ‘Jan hasn’t bought the book, but the record.’
- b. Ook/Alleen de *PLAAT* heeft Jan gekocht.  
 also/only the record has Jan bought  
 ‘Jan has also/only bought the record.’
- c. Zelfs *PETER* heb ik gezien.  
 even Peter have I seen  
 ‘I have even seen Peter.’

Of course, much more can be said about the meaning of focus particles, but we will not digress on this here and refer the reader instead to studies such as König (1991), Foolen (1993) and Barbiers (1995).

Now that we have established that focus particles may form a constituent with contrastively focused phrases, we can discuss the hypothesis that focus movement is required to assign scope to the contrastively focused phrase. The examples in (141) show that while prepositional objects normally follow sentence negation, they can precede negation if they are contrastively focused. Since we have seen that focus movement normally targets a position preceding sentence negation, the fact that the contrastively focused PP can follow *niet* is a potential problem for the hypothesis that focus movement is obligatory.

- (141) a. Jan wil <\*naar ’m> niet <naar ’m> luisteren.  
 Jan wants to him not listen  
 ‘Jan doesn’t want to listen to him.’
- b. Jan wil <naar *HEM*> niet <naar *HEM*> wil luisteren.  
 Jan wants to him not wants listen  
 ‘Jan doesn’t want to listen to him.’

In (142) we provide similar focus constructions as in (141b), but now with a focus particle present. If such particles can indeed form a constituent with the contrastively focused PP and if focus movement is obligatory, we correctly predict that the presence of these focus particles requires that the prepositional object is moved across negation.

- (142) a. Jan wil <alleen naar *HEM*> niet <\*alleen naar *HEM*> luisteren.  
 Jan wants only to him not listen  
 ‘Jan doesn’t want to listen to him only.’
- b. Jan wil <ook naar *HEM*> niet <\*ook naar *HEM*> luisteren.  
 Jan wants also to him not listen  
 ‘Jan doesn’t want to listen to him either.’
- c. Jan wil <zelfs naar *HEM*> niet <\*zelfs naar *HEM*> luisteren.  
 Jan wants even to him not listen  
 ‘Jan doesn’t want to listen even to him.’

The examples in (142) thus support the claim that focus movement is obligatory. Similar examples, in which the contrastively focused PP is embedded in an adjectival °complementive, are given in (143). The fact that the PPs must precede

the adjective if they are accompanied by a focus particle again shows that focus movement is obligatory; cf. Barbiers (2014).

- (143) a. dat Jan <(alleen) op *HEM*> boos <(\*alleen) op *HEM*> is.  
 that Jan only at him angry is  
 ‘that Jan is only angry with him.’
- b. dat Jan <(ook) op *HEM*> boos <(\*ook) op *HEM*> is.  
 that Jan also at him angry is  
 ‘that Jan is also angry with him.’
- c. dat Jan <(zelfs) op *HEM*> boos <(\*zelfs) op *HEM*> is.  
 that Jan only at him angry is  
 ‘that Jan is even angry with him.’

The examples in (142) and (143) strongly suggest that the optionality of focus movement in examples such as (141b) is only apparent. One potential alternative analysis is that *niet* does not function as sentence negation but as constituent negation if the contrastively focused phrase follows it: if so, we may assume that we are dealing with the phrase *niet op HEM*, which occupies the specifier of FocP as a whole.

The examples in (144) show that the examples in (142) and (143) alternate with constructions in which the designated focus position is filled not by the full contrastively focused phrase but by the focus particle only.

- (144) a. Jan wil alleen/ook/zelfs niet naar *HEM* luisteren.  
 Jan wants only/also/even not to him listen  
 ‘Jan doesn’t want to listen to him only/to him either/even to him.’
- b. dat Jan alleen/ook/zelfs boos <op *HEM*> is.  
 that Jan only/also/even angry at him is  
 ‘that Jan is angry with him only/with him as well/even with him.’

This feature is normally optional, with the exception of cases in which the associate of the focus particle is a complement clause: as usual, such clauses are located after the verbs in clause-final position. We illustrate this in (145a-b) by means of the focus particles *alleen* but similar examples can be constructed for the other focus particles; example (145c) is added to show that the focus particle and the clause can make up a constituent.

- (145) a. Jan heeft alleen gemeld [*DAT* hij niet zou komen], niet *WAAROM*.  
 Jan has only reported that he not would come not why  
 ‘Jan has only reported that he wouldn’t come (he didn’t say why).’
- b. ??Jan heeft alleen [*DAT* hij niet zou komen] gemeld.
- c. Alleen *DAT* hij niet zou komen heeft hij gemeld.

Barbiers (2010) proposed that examples such as (144b) are derived by subextraction of the focus particle from the contrastively focused phrase, as in (146a); if this is correct, we can maintain in full force the hypothesis that focus movement is obligatory. An alternative hypothesis would be that the focus particle is base-generated in the specifier of FocP as a scope marker (analogous to English negative clauses such as *John hasn’t seen anybody*, in which the specifier of NegP is filled

by the negative adverb *not*). If this alternative is correct, we have to revise the hypothesis that focus movement is obligatory by stating that the specifier position of FocP must be filled.

- (146) a. ... [<sub>FocP</sub> PRT<sub>i</sub> Foc ... [<sub>LD</sub> .. [<sub>t<sub>i</sub></sub> PP<sub>A-accent</sub>]] ...] [movement analysis]  
 b. ... [<sub>FocP</sub> PRT Foc ... [<sub>LD</sub> ... [PP<sub>A-accent</sub>]] ...] [base-generation analysis]

It is not easy to distinguish between the two hypotheses. Barbiers supports the movement analysis by claiming that the focus particle can be moved further into clause-initial position; he demonstrates this subextraction by means of *ook*, but unfortunately the result becomes degraded with the particles *alleen* and *zelfs*. It is not so clear what the base-generation hypothesis predicts: if the comparison with *not* in negative clauses such as *John hasn't seen anybody* is taken seriously, we may expect the focus particle to remain in its scope position. Example (147b) shows that we come across similar judgments if we move the contrastively focused PP across the particle; this example is only acceptable if the preposed PP is assigned a B-accent, that is, if it functions as a contrastive topic, in which case the adjective would normally be contrastively focused.

- (147) a. *Ook*/?/? *Alleen*/?/? *Zelfs* is Jan [boos op *HEM*].  
 also/only/even is Jan angry at him  
 'Jan is also/only/even angry with him.'  
 b. Op *HEM<sub>i</sub>* is Jan *ook*/?/? *alleen*/?/? *zelfs* [boos *t<sub>i</sub>*].  
 at him is Jan also/only/even angry

### 3. Scalar focus particles

Scalar focus particles like *pas* 'just/only', *al* 'already', *nog* 'still' and *maar* 'just' must be associated with phrases denoting a linearly ordered scale. The focused phrase is typically a noun phrase containing a numeral or a quantifier, as illustrated in (148). The numeral/quantifier selects a specific value from some contextually defined numerical scale (say, from one to twenty), and the particles qualify the part of the scale that is covered: *maar* 'just' indicates that this part is smaller than anticipated while *al* 'already' indicates that this part is larger than anticipated. The fact that the particle and the focused phrase can be placed in sentence-initial position shows that they form a constituent.

- (148) a. We hebben *maar DRIE/WEINIG* boeken gelezen.  
 we have just three/few books read  
 'We have read just three/a few books.'  
 a'. *Maar DRIE/WEINIG* boeken hebben we gelezen.  
 just three/few books have we read  
 b. Hij heeft *al TIEN/VEEL* boeken gelezen.  
 he has already ten/many books read  
 'He has read ten/many books already.'  
 b'. *Al TIEN/VEEL* boeken heeft hij gelezen.  
 already ten/many books has he read

In example (149a), the particles *nog* ‘still’ and *al* ‘already’ function as temporal adverbial modifiers of the °eventuality denoted by *Jan werken*: the eventuality continues longer/starts earlier than might have been expected. In example (149b) the particles *al* ‘already’ and *pas* ‘just’ function as adverbial modifiers qualifying the distance between speech time and the start of the eventuality: they characterize it as, respectively, longer and shorter than might have been expected. The adverbial use of the particle *maar* is restricted to non-stative verbs and expresses durative aspect: *Jan praat maar* ‘Jan keeps on talking’. Although Barbiers (1995:ch3) has shown that these temporal uses also involve modification of a linearly ordered scale (the time axis), we will ignore such cases in the discussion below.

- (149) a. Jan werkt nog/al.  
 Jan works still/already  
 ‘Jan is still/already working.’  
 b. Jan werkt hier al/pas sinds februari  
 Jan works here already/just since February  
 ‘Jan has been working here since February already/only since February.’

The scalar focus particles in (148) modify nominal arguments but the (a)-examples in (150) show they can also modify noun phrases embedded in a PP. The (b)-examples further show that it is also possible for such particles to modify the PP as a whole, with apparently the same meaning. The fact that the PP must precede the adjective *geïnteresseerd* ‘interested’ that selects it in all these examples shows that focus movement is obligatory in these cases.

- (150) a. dat Jan <in maar ÉÉN ding> geïnteresseerd <\*in maar ÉÉN ding> is.  
 that Jan in just one thing interested is  
 ‘that Jan is interested in just one thing.’  
 a’. In maar ÉÉN ding is Jan geïnteresseerd.  
 in just one thing is Jan interested  
 b. dat Jan <maar in ÉÉN ding> geïnteresseerd <\*maar in ÉÉN ding> is.  
 that Jan in just one thing interested is  
 ‘that Jan is interested in just one thing.’  
 b’. Maar in ÉÉN ding is Jan geïnteresseerd.’  
 just in one thing is Jan interested

That focus movement is obligatory is illustrated for direct objects in (151): while the definite noun phrase *het boek* ‘the book’ can readily follow the manner adverb *zorgvuldig* in (151a), the phrase modified by *al* must precede it.

- (151) a. Hij heeft <de boeken> nauwkeurig <de boeken> gelezen.  
 he has the books meticulously read  
 ‘He has read the books meticulously.’  
 b. Hij heeft <al TIEN boeken> nauwkeurig <\*al TIEN boeken> gelezen.  
 he has already ten books meticulously read  
 ‘He has meticulously read ten books already.’

Scalar and counter-presuppositional focus particles are similar in that they both trigger focus movement but they cannot be taken to belong to a single category as

they exhibit different behavior in other respects (although we will see that the judgments on the relevant data are not very clear). First, the examples in (152) show that scalar focus particles differ from the counter-presuppositional ones in that they are preferably adjacent to the focused phrase; cf. the examples in (144). Although examples such as (152) are rated as fully acceptable in Barbiers (2010), we have assigned them a percentage sign because a Google search (7/2/2015) on the strings [*maar in één ding geïnteresseerd is*] and [*maar geïnteresseerd in één ding is*] revealed that only the former can be found on the internet (23 hits). Since we also found cases in which the PP is extraposed (2 hits), the search results on the corresponding strings with the finite verb *is* preceding *maar* should be considered less reliable (46 versus 13 hits).

- (152) a. %Hij heeft al nauwkeurig TIEN boeken gelezen.  
 he has already meticulously ten books read  
 b. %dat Jan maar geïnteresseerd in ÉÉN ding is.  
 that Jan just interested in one thing is

Second, the examples in (153) show that scalar focus particles can more easily follow the focused phrase than counter-presuppositional ones; cf. example (147b). Nevertheless, our Google search suggests that this option is dispreferred as well: while the search string [*maar in één ding geïnteresseerd*] resulted in more than a hundred hits, the search strings [*in één ding maar geïnteresseerd*] and [*in één ding \*maar geïnteresseerd*] did not yield any results.

- (153) a. %We hebben DRIE/WEINIG boeken maar gelezen.  
 we have three/few books just read  
 a'. DRIE/WEINIG boeken hebben we maar gelezen.  
 three/few books have we just read  
 'We have read three books only/only a few books.'  
 b. %Jan is in ÉÉN ding maar geïnteresseerd.  
 Jan is in one thing just interested  
 b'. In ÉÉN ding is Jan maar geïnteresseerd.'  
 in one thing is Jan just interested  
 'Jan is interested in just one thing.'

Note in passing that the fact that scalar focus particles may either precede or follow the focus phrase may give rise to ambiguity. Example (154) provides slightly adapted cases from Barbiers (1995:70); the intended interpretation is indicated by means of square brackets.

- (154) a. Jan heeft ÉÉN meisje [pas TWEE boeken] gegeven.  
 Jan has one girl just two books given  
 'Jan has given one girl just two books.'  
 b. %Jan heeft [ÉÉN meisje pas] TWEE boeken gegeven.  
 Jan has one girl just two books given  
 'Jan has given just one girl two books.'

Third, although (153b') suggests that scalar focus particle can be "stranded" in the middle field of the clause, the examples in (155) show that they cannot be



topicalized by themselves; the results are clearly more degraded than the comparable examples with counter-presuppositional focus particles in (147a).

- (155) a. \*Maar hebben we *DRIE/WEINIG* boeken gelezen.  
 just have we three/few books read  
 b. \*Maar is Jan in *ÉÉN* ding geïnteresseerd.  
 just is Jan in one thing interested  
 c. \*Al heeft hij *TIEN/VEEL* boeken gelezen.  
 already has he ten/many books read

#### 4. On the nature of scalar and counter-presuppositional focus particles

Barbiers (2010/2014) has shown that scalar and counter-presuppositional focus particles also differ in that the former can be doubled in certain varieties of Dutch while the latter cannot. This contrast is illustrated by the examples in (156), which involve the stative verb *kennen* ‘to know’ in order to exclude a temporal reading of the second occurrence of *maar*; the temporal reading arises with dynamic verbs only. The percentage sign in the (b)-examples indicates that some speakers of the standard variety do not (easily) accept doubling of scalar focus particles.

- (156) a. Alleen/ook *JAN* ken ik (\*alleen/\*ook). [counter-presuppositional]  
 only/also Jan know I only/also  
 ‘I only/also know Jan.’  
 b. Maar *ÉÉN* schrijver ken ik (% maar). [scalar]  
 just one writer know I just  
 ‘I know just one writer.’  
 b'. Al *TIEN* boeken heeft hij (% al). [scalar]  
 already ten books has he already  
 ‘He has ten books already.’

Barbiers also observes that counter-presuppositional and scalar focus particles sometimes co-occur (with a slight difference in meaning in the case of *ook ... al*). The examples in (157) show that in such cases the former precede the latter. The diacritics in the (b)-examples indicate that some speakers of the standard variety may find these examples somewhat marked.

- (157) a. Jan is *ook* op *MARIE* *al* boos geweest.  
 Jan is also at Marie already angry been  
 ‘Jan has also been angry with Marie already.’  
 a'. *Ook* op *MARIE* is Jan *al* boos geweest.  
 also at Marie is Jan already angry been  
 b. <sup>(?)</sup>Jan is *alleen* op *MARIE* *maar* boos geweest.  
 Jan is only at Marie just angry been  
 ‘Jan has only been angry with Marie.’  
 b'. <sup>(?)</sup>*Alleen* op *MARIE* is Jan *maar* boos geweest.  
 only at Marie is Jan just angry been

The examples in (158) show that counter-presuppositional focus particles may also occur in front of the scalar focus particle, with the contrastively focused phrase in its base position.

- (158) a. Jan is *ook al* boos op *MARIE* geweest.  
 Jan is also already angry at Marie been  
 a'. ?*Ook* is Jan *al* boos op *MARIE* geweest.  
 also is Jan already angry at Marie been  
 b. Jan is *alleen maar* boos op *MARIE* geweest.  
 Jan is only just angry at Marie been  
 b'. ??*Alleen* is Jan *maar* boos op *MARIE* geweest.  
 only is Jan just angry at Marie been

Barbiers accounts for the data in (157) by assuming that scalar but not counter-presuppositional focus particles may be the head of a functional projection, which we will assume to be FocP. The primeless examples in (157) can now be derived by moving the contrastively focused phrase into the specifier of FocP, as indicated in (159a), while the primed examples can be derived from this structure by subsequent topicalization of the contrastively focused phrase. The primeless examples in (158) can be derived by placing the counter-presuppositional focus particles into the specifier position of FocP; we will leave open whether this is the result of subextraction of the focus particle from the contrastively focused phrase or whether the focus particle is base-generated as a scope marker in the specifier of FocP; cf. the discussion of (146). The fact that the primed examples in (158) are marked may be due to the fact that the particles are not sufficiently contentful to undergo topicalization.

- (159) a. Jan is ... [<sub>FocP</sub> [ook/alleen op Marie]<sub>i</sub> [[<sub>Foc</sub> al/maar] [<sub>LD</sub> [<sub>AP</sub> boos *t<sub>i</sub>*] geweest]]].  
 b. Jan is ... [<sub>FocP</sub> ook/alleen [[<sub>Foc</sub> al/maar] [<sub>LD</sub> [<sub>AP</sub> boos op Marie] geweest]]].

If scalar focus particles do not only occur as the head of FocP but can also be used to modify a contrastively focused phrase, doubling of such particles can be derived in a similar way as indicated in (159a); cf. (160a). Since the head of FocP may remain phonetically empty and scalar focus particles are not obligatory, the cases without doubling can be analyzed as in (160b&c); examples without any focus particle of course have the structure in (160d).

- (160) a. %Jan is [<sub>FocP</sub> [maar op *ÉÉN* jongen]<sub>i</sub> [[<sub>Foc</sub> maar] [<sub>LD</sub> [<sub>AP</sub> boos *t<sub>i</sub>*] geweest]]].  
 b. Jan is [<sub>FocP</sub> [maar op *ÉÉN* jongen]<sub>i</sub> [[<sub>Foc</sub> Ø] [<sub>LD</sub> [<sub>AP</sub> boos *t<sub>i</sub>*] geweest]]].  
 c. Jan is [<sub>FocP</sub> [op *ÉÉN* jongen]<sub>i</sub> [[<sub>Foc</sub> maar] [<sub>LD</sub> [<sub>AP</sub> boos *t<sub>i</sub>*] geweest]]].  
 d. Jan is [<sub>FocP</sub> [op *ÉÉN* jongen]<sub>i</sub> [[<sub>Foc</sub> Ø] [<sub>LD</sub> [<sub>AP</sub> boos *t<sub>i</sub>*] geweest]]].

Recall from the discussion of (152) that there are reasons for assuming that scalar focus particles cannot occur in the specifier of FocP, which would be supported by the fact that they cannot occur in structures such as (159b) either. This restriction would follow immediately if we assume that scalar focus particles are never phrasal in nature, and specifier positions can be filled by maximal projections only.

The claim that scalar focus particles may function as the head of FocP may also account for the contrast between the two examples in (161). Barbiers (1995:84-5) noticed that while the particle *maar* cannot be construed as a modifier of the direct object *twee vogels* of the embedded clause in (161a), this is possible in (161b) where the direct object is extracted from the clause by topicalization. This can be

made to follow from the analysis discussed above: example (161a) is unacceptable under the intended reading because the object has failed to undergo long focus movement, while (161b) is acceptable under this reading on the assumption that long focus movement precedes topicalization. The contrast between the two examples thus supports our earlier claim that the specifier of FocP must be filled in order to assign scope to the contrastively focused phrase.

- (161) a. <sup>#</sup>Jan zei maar dat hij *TWEE* vogels gezien had.  
 Jan said just that he two birds seen had  
 a'. Jan zei [<sub>FocP</sub> ... maar [<sub>LD</sub> *t*<sub>said</sub> [<sub>CP</sub> dat hij *TWEE* vogels gezien had]]].  
 b. *TWEE* vogels zei Jan maar [dat hij gezien had]].  
 two birds said Jan just that he seen had  
 'Jan said that he had seen just two birds.'  
 b'. [*TWEE* vogels]<sub>i</sub> zei Jan [<sub>FocP</sub> *t*'<sub>i</sub> maar [<sub>LD</sub> *t*<sub>said</sub> [<sub>CP</sub> dat hij *t*<sub>i</sub> gezien had]]].

The examples discussed in this subsection suggest that scalar and counterpresuppositional focus particles have a different syntactic status: while the latter are arguably heads in all their manifestations, the former show a more projection-like behavior. We will leave this for future research and refer the reader to Barbiers (2014) for an alternative proposal.

## 5. Conclusion

The discussion above has shown that the hypothesis that focus movement is obligatory in Dutch can be upheld, provided we assume that the negative element *niet* is a focus particle if it expresses constituent negation; this receives independent support from the fact that *niet* and its associate phrase can be placed in clause-initial position together. Constructions with focus particles separated from their associate focused phrase may be an exception to the general rule if focus particles are base-generated in the specifier position of FocP as scope markers in such cases (in the same way as *niet* is base-generated in the specifier of NegP in English negative clauses): on this assumption we have to fine-tune the hypothesis that focus movement is obligatory by granting that the specifier position of FocP must be filled.

## II. Topic movement

While the linguistic literature on Dutch frequently refers to focus movement within the middle field of the clause, this rarely applies to topic movement. Furthermore, when concrete examples of topic movement are discussed, they are often considered to involve focus movement. Attempts to distinguish the two cases systematically started with the publication of Neeleman & Van de Koot (2008). Because the study of topic movement is still in its infancy, we will confine our discussion to a small number of core issues.

The introduction to this section has already made it clear that contrastive topics are marked by a B-accent. Semantically speaking, they imply that there is at least one other potential discourse topic that the speaker could have addressed. For instance, the plurality of the finite verb in question (162a) indicates that the speaker has reason to believe that there is a non-singleton contextually defined set of

individuals *E*, that a subset of these individuals have been invited to the party mentioned, and that the identity of these individuals in this subset is known to the addressee. The answer in (162b) does not provide an answer to the question but asserts something about only one of the individuals from *E*.

- (162) a. Wie zijn er uitgenodigd voor het feest? [question]  
 who are there invited for the party  
 ‘Who are invited for the party?’  
 b. Geen idee. Ik weet alleen dat Peter niet kan komen. [answer]  
 no idea I know only that Peter not can come  
 ‘No idea. I only know that Peter cannot come.’

There may be various reasons why a speaker chooses to use a contrastive topic construction: he may for instance be unable or unwilling to provide the requested information. Buring (2007) notes, however, that contrastive topic constructions often introduce an adversative implicature in the sense that the comments associated with the contrasted discourse topics are different. For example, the answer in (163b) strongly suggests that the boy dancers did *not* wear miniskirts.

- (163) a. Wat droegen de dansers?  
 what wore the dancers  
 ‘What did the dancers wear?’  
 b. De meisjes droegen korte rokjes.  
 the girls wore short skirts  
 ‘The girls wore miniskirts.’

The question-answer pair in (164a&b) shows that topic movement may involve a PP and that we are therefore dealing with A'-movement. We will assume that the contrastive topic is moved into the specifier of a TopP in the functional domain of the clause, which would be in line with the claim in Neeleman & Van de Koot (2008) that topic movement is instrumental in distinguishing contrastive topics from the comments that provide more information about them. If we are dealing with A'-movement, we expect topic movement to be obligatory: judgments are not very clear but it does seem that the answer in (164b) is more natural with the contrastive B-accent in (113) than the one in (164b'). Example (164b') is of course felicitous without the B-accent, but this seems to disfavor the adversative implicature that the person answering the question is less fond of the children not mentioned.

- (164) a. Wat vind je van mijn kinderen? Je weet ...  
 what find you of my children you know  
 ‘How do you feel about my children?’  
 b. dat ik [<sub>TopP</sub> [op je zoon]<sub>i</sub> Top [<sub>LD</sub> [<sub>AP</sub> erg dol *t*<sub>i</sub>] ben]].  
 that I of your son very fond am  
 ‘(You know) that I am very fond of your son.’  
 b'. \*dat ik [<sub>LD</sub> [<sub>AP</sub> erg dol [op je zoon] ben]].  
 that I very fond of your son am  
 ‘(You know) that I am very fond of your son.’

That the landing site is inside the functional domain of the clause is clear from the fact that it must precede negation, which was shown to be external to the lexical domain of the clause in Section 13.3.1. This is illustrated in (165) by means of the negative counterpart of (164b).

- (165) a. dat ik [<sub>TOPP</sub> [op je zoon]<sub>i</sub> Top [<sub>NegP</sub> niet Neg [<sub>LD</sub> [<sub>AP</sub> erg dol *t*<sub>i</sub>] ben]]].  
 that I of your son not very fond am  
 ‘(You know) that I am not very fond of your son.’  
 b. \*dat ik [<sub>NegP</sub> niet Neg [<sub>TOPP</sub> [op je zoon]<sub>i</sub> Top [<sub>LD</sub> [<sub>AP</sub> erg dol *t*<sub>i</sub>] ben]]].  
 that I not of your son very fond am

Contrastive topics also precede contrastive foci, as is clear from the examples in (166), which show that the contrastive topic must not only precede negation but also the contrastive focus (which is signaled here by *zelfs* ‘even’). It should be noted that example (166b) sounds much better if the focus particle *zelfs* is omitted, which suggests that in such cases the contrastively focused subject pronoun can be moved into the regular subject position (right-adjacent to the complementizer *dat*).

- (166) a. dat op je zoon zelfs IK niet erg dol ben.  
 that of your son even I not very fond am  
 ‘(You know) that even I am not very fond of your son.’  
 b. ??dat zelfs IK op je zoon niet erg dol ben.  
 that even I of your son not very fond am  
 c. \*dat zelfs IK niet op je zoon erg dol ben.  
 that even I not of your son very fond am

In this connection it should be noted that contrastive topics cannot cross a non-focused subject, that is, as subject in regular subject position; the starred word order in (167b) seems to be possible only in contexts that allow contrastive focus accent on the subject *Marie* and (167c) is unacceptable in any context given that weak pronouns can never be assigned accent.

- (167) a. Wat vindt Marie van mijn kinderen? Ik denk ...  
 what finds Marie of my children I think  
 ‘How does Marie feel about my children?’  
 b. dat <Marie> op je zoon <\*Marie> [<sub>LD</sub> [<sub>AP</sub> erg dol *t*<sub>i</sub>] is].  
 that Jan of your son very fond is  
 ‘(I think) that Marie is very fond of your son.’  
 c. dat <ze> op je zoon <\*ze> [<sub>LD</sub> [<sub>AP</sub> erg dol *t*<sub>i</sub>] is].  
 that she of your son very fond is  
 ‘(I think) that she is very fond of your son.’

### III. Controversial issues

The study of focus and, especially, topic movement in Dutch had a recent start in Neeleman & Van de Koot (2008): a number of more recent contributions can be found in Neeleman & Vermeulen (2012). The results of these studies are not unequivocal in view of many unclear issues at the empirical level. It is now uncontroversial that focus and topic movement can take place into some position in the functional domain of the clause; that the landing sites of these two movements

precede the position occupied by phrases expressing sentence negation, and that topic movement targets a position to the left of the position targeted by contrastively focused phrases.

(168) ... [<sub>TopP</sub> ... Top [<sub>FocP</sub> .. Foc [<sub>NegP</sub> ... Neg [<sub>LD</sub> ...]]]]

There is debate about the question as to whether focus and topic movement are obligatory: Neeleman & Van de Koot (2008) claim that these movements are optional in principle, while Barbiers (2010/2014) maintains that, at least for contrastive foci, movement must take place in order to arrive at a coherent interpretation. For focus movement in Dutch the issue is not empirical in nature, as Neeleman & Van de Koot motivate their claim on English data, but it *is* in the case of topic movement: Neeleman & Van de Koot provide several constructions of which they claim that they contain a contrastive topic *in situ*. We provided one simple case not discussed by them in (164) and our intuitions on the (b)-examples suggest that the contrastive topic reading is less easy to get if the phrase in question remains *in situ*. In our view, the claim that contrastive topics can remain *in situ* should be investigated more thoroughly before accepting it.

Neeleman & Van de Koot (2008) also claim that focus and topic movement are able to change the unmarked order of nominal arguments, although they admit that this claim is problematical in the case of focus movement (see fn.2 of their article). Nevertheless, it seems uncontroversial that topic movement can affect the order of subjects and objects if the latter are focused, cf. (166). More examples taken from Neeleman (1994a/1994b) are given in (169).

- (169) a. dat Jan zelfs *MARIE* zulke boeken niet geeft.  
 that Jan even Marie such books not gives  
 ‘that Jan doesn’t give even Marie such books.’  
 a’. dat Jan zulke boeken zelfs *MARIE* niet geeft.  
 that Jan such books even Marie not gives  
 b. dat zelfs *JAN* zulke boeken niet koopt.  
 that even Jan such books not buys  
 ‘that even Jan does not buy such books.’  
 b’. dat zulke boeken zelfs *JAN* niet koopt.  
 that such books even Jan not buys

In fact, focus/topic movement can also affect the unmarked order of nominal arguments and complementives, which is illustrated by means of the following examples again adapted from Neeleman (1994a/1994b).

- (170) a. dat <\*groen> Jan <\*groen> de deur niet <groen> wil verven.  
 that green Jan the door not wants paint  
 ‘that Jan doesn’t want to paint the door green.’  
 b. dat Jan <zo groen> zelfs de *DEUR* niet wil verven.  
 that Jan that green even the door not wants paint  
 ‘that Jan doesn’t want to paint even the door that green.’  
 b’. dat <zo groen> zelfs *JAN* de deur niet wil verven.  
 that that green even Jan the door not wants paint  
 ‘that even Jan doesn’t want to paint the door that green.’

A more problematic claim, found in Neeleman & Van de Koot (2008:162-3), is that focus/topic movement can also move across non-focused subjects, since this is rejected by at least some of our informants (including the authors of this volume). This was already indicated in the (b)-examples in (167) and we illustrate this again in (171) for the examples in (169b') and (170).

- (171) a. dat zulke boeken %Jan/\*hij niet koopt.  
 that such books Jan/he not buys
- b. %dat zelfs DE DEUR %Jan/\*hij niet groen wil verven.  
 that even the door Jan/he not green wants paint
- b'. %dat <zo groen> zelfs DE DEUR %Jan/\*hij niet wil verven.  
 that that green even the door Jan/he not wants paint

The percentage signs indicate that this issue should be investigated more carefully before we can say something definitive, although it seems already clear from the fact that the pronoun cannot be used that the target position of focus and topic movement is to the right of the regular subject position (the specifier of TP).

### 13.3.3. Conclusion

This section has discussed A'-scrambling, which involves negation, focus and topic movement. We have seen that there are reasons for assuming that negative phrases expressing sentence negation are obligatorily moved into the specifier position of the functional projection NegP, from which they can take scope over the proposition expressed by the lexical domain of the clause. Similarly, contrastive foci and topics are obligatorily moved into the specifier of FocP and TopP, from where they can take scope over their associated backgrounds/comments, which can again be taken to be located in the lexical domain of the clause. The fact that contrastive foci are often higher in the structure than phrases expressing sentence negation, while contrastive topics are higher than contrastive foci leads to the overall structure in (172), where the brackets without labels stand for potential functional projections that may still be discovered by future research.

- (172) [CP ... C [TP ... T [ ... [TopP Top [... [FocP Foc [... [NegP ... Neg [LD ....]]]]]]]]]]

The representation in (172) is conspicuously similar to what we find in languages such as Hungarian, which are strongly templatic in the sense that there is a strict order of phrases of various semantic types: topic > focus > neg. It therefore need not surprise us that the description of the Hungarian functional domain provided in É.Kiss (2002) is essentially similar to the one given in (172), although it adds a functional projection between TopP and FocP which provides a landing site for certain quantified expressions, especially those involving a universal quantifier or a numeral expression such as *sok* 'many', *számos* 'several' and *több mint n* 'more than n'. We might therefore expect that such phrases also undergo A'-movement in languages other than Hungarian: although Svenonius (2000) and Christensen (2005) have shown that this expectation is indeed borne out for Icelandic, it still remains to be shown for Dutch. Although further comparison of Dutch and Hungarian is needed in order to get a more complete picture of the similarities and differences



between these languages, the fact that the functional domains of the clause in unrelated languages like Dutch and Hungarian are so similar gives credibility to the hypothesis that this domain is at least partly determined by certain universal (perhaps semantic) properties of the language system.

**13.4. Weak proform shift**

Weak (phonetically reduced) proforms normally occur in the left periphery of the middle field of the clause, with the exception of weak subject pronouns, which may also occur in clause-initial position; cf. Section 9.3. We can distinguish the three groups of weak elements in (173), all of which have strong counterparts with the exception of expletive and partitive *er*.

- (173) • Weak proforms
  - a. Referential personal pronouns; *ie/ze* ‘he/she’, *’m/’r* ‘him/her’, etc.
  - b. Reflexive personal pronouns: *me* ‘myself’, *je* ‘yourself’, *zich* ‘him/herself’, etc.
  - c. the R-word *er*: expletive, locational, prepositional and quantitative

The set of elements in (173) closely resembles the set of clitics found in French: see the lemma *French personal pronouns* at Wikipedia for a brief review. We will see that the relative order of the weak proforms also exhibits a number of similarities with the French clitics, which may justify the claim that the Dutch weak proforms are clitics as well; see Huybregts (1991), Zwart (1993/1996) as well as Haegeman (1993a/1993b) on W-Flemish. It should be noted, however, that the Dutch proforms differ from French clitics in that they do not need a verbal host: while the French clitics always cluster around a main or an auxiliary verb, the Dutch proforms do not require this. In order to not bias the discussion beforehand, we will refer to the movement that places weak proforms in the left periphery of the middle field as WEAK PROFORM SHIFT. Subsection I starts with a discussion of the weak referential personal pronouns, Subsection II discusses the weak (simplex) reflexive pronouns, and Subsection III concludes with the various uses of the weak R-word *er*.

*I. Referential personal pronouns*

Table 2 shows the classification of referential personal pronouns, which is more extensively discussed in Section N5.2.1. The discussion in this subsection focuses on the distribution of the weak forms.

Table 2: Referential personal pronouns

		SINGULAR				PLURAL			
		SUBJECT		OBJECT		SUBJECT		OBJECT	
		strong	weak	strong	weak	strong	weak	strong	weak
1 <sup>ST</sup> PERSON		<i>ik</i>	<i>’k</i>	<i>mij</i>	<i>me</i>	<i>wij</i>	<i>we</i>	<i>ons</i>	—
2 <sup>ND</sup> PERSON	REGULAR	<i>jij</i>	<i>je</i>	<i>jou</i>	<i>je</i>	<i>jullie</i>	—	<i>jullie</i>	—
	POLITE	<i>u</i>		<i>u</i>		<i>u</i>		<i>u</i>	
3 <sup>RD</sup> PERSON	MASCULINE	<i>hij</i>	<i>-ie</i>	<i>hem</i>	<i>’m</i>	<i>zij</i>	<i>ze</i>	<i>hen<sub>acc</sub></i>	<i>ze</i>
	FEMININE	<i>zij</i>	<i>ze</i>	<i>haar</i>	<i>(d)’r</i>			<i>hun<sub>dat</sub></i>	
	NEUTER	<i>’het</i>	<i>’t</i>	<i>*’het</i>	<i>’t</i>				

A. *Weak pronominal subjects of (in)transitive verbs*

In embedded clauses weak subject pronouns are right-adjacent to the complementizer (if present), and immediately precede or follow the finite verb in second position in main clauses; cf. Paardekoooper (1961). This is illustrated in (174) by means of the 3<sup>rd</sup> person singular feminine pronoun *ze* 'her'.

- (174) a. dat ze waarschijnlijk morgen komt. [embedded clause]  
 that she probably tomorrow comes  
 'that she's probably coming tomorrow.'
- b. Ze komt waarschijnlijk morgen. [subject-initial main clause]  
 she comes probably tomorrow  
 'She's probably coming tomorrow.'
- b'. Waarschijnlijk komt ze morgen. [other main clauses]  
 probably comes she tomorrow  
 'Probably she's coming tomorrow.'

The examples in (175) show that subject pronouns can occur in positions more to the right only if they are strong and carry contrastive focus accent. The question mark in example (175b) is used to indicate that even then strengthening of the pronoun by means of a focus particle is often preferred.

- (175) a. \*dat waarschijnlijk ze morgen komt.  
 that probably she tomorrow comes
- b. dat waarschijnlijk ?(zelfs) *ZIJ* morgen komt.  
 that probably even she tomorrow comes  
 'that even she is probably coming tomorrow.'

The examples in (176) show that the singular third person masculine subject pronoun *ie* 'he' is exceptional in that it cannot occur in clause-initial position: it is a truly enclitic pronoun in that it obligatorily follows the complementizer or the finite verb in second position.

- (176) a. dat-ie waarschijnlijk morgen komt. [embedded clause]  
 that-he probably tomorrow comes  
 'that he's probably coming tomorrow.'
- b. Hij/\*Ie komt waarschijnlijk morgen. [subject-initial main clause]  
 he/he comes probably tomorrow  
 'He's probably coming tomorrow.'
- b'. Waarschijnlijk komt-ie morgen. [other main clauses]  
 probably comes-he tomorrow  
 'Probably he's coming tomorrow.'

Example (177) shows that weak subject pronouns differ conspicuously from weak object pronouns in that the latter cannot occur in sentence-initial position.

- (177) a. Gisteren heeft Jan het boek/'t gelezen.  
 yesterday has Jan the book/it read  
 'Yesterday Jan read the book/it.'
- b. Het boek/\*'t heeft Jan gisteren gelezen.  
 the book/it has Jan yesterday read

This fact motivated the claim in (178) that subject-initial sentences are not CPs but TPs, as this hypothesis makes it possible to maintain the generalization that weak pronouns cannot be topicalized, that is, *wh*-moved into the specifier of CP; we refer the reader to Section 9.3 for detailed discussion.

- (178) a. • Subject-initial sentence
- 
- b. • Other main clauses
- 

### B. Weak pronominal objects

This subsection discusses weak proform shift of object pronouns. In succession, we will address the placement of weak object pronouns with respect to subjects, the relative order of weak direct and indirect object pronouns, and the relative order of weak object pronouns with respect to accusative subjects of °AcI-constructions.

#### 1. Order of subject and weak object pronouns in main clauses

Example (177) above has already shown that weak object pronouns cannot occur in sentence-initial position but must occupy a position in the middle field of the clause. The examples in (179) further show that they immediately follow the subject if it is not in sentence-initial position; cf. Huybregts (1991). This does not only hold if the subject is in the regular subject position, as in the primeless examples, but also if it is contrastively focused and can be assumed to be located in the specifier of FocP lower in the clause, as in the primed examples; cf. Section 13.3.2.

- (179) a. dat <\*'t> Jan/ie <'t> waarschijnlijk <\*'t> niet gelezen heeft  
 that it Jan/he probably not read has  
 'that Jan/he probably hasn't read it.'
- a'. dat <\*'t> waarschijnlijk zelfs JAN <'t> niet gelezen heeft.  
 that it probably even Jan not read has  
 'that even Jan probably hasn't read it.'
- b. dat <\*'m> Marie/ze <'m> waarschijnlijk <\*'m> goede raad wil geven.  
 that him Marie/she probably good advice wants give  
 'that Marie/she probably wants to give him good advice.'
- b'. dat <\*'m> waarschijnlijk zelfs MARIE <'m> goede raad wil geven.  
 that him probably even Marie good advice wants give  
 'that even Marie probably wants to give him good advice.'

In subject-initial main clauses, weak object pronouns immediately follow the finite verb in second position. This is illustrated in (180) by showing that modal adverbs cannot precede the object pronoun but this holds for other constituents as well.

- (180) a. Jan heeft <'t> waarschijnlijk <\*'t> niet gelezen.  
 Jan has it probably not read  
 'Jan probably hasn't read it.'
- b. Marie wil <'m> waarschijnlijk <\*'m> goede raad geven.  
 Marie wants him probably good advice give  
 'Marie probably wants to give him good advice.'

## 2. *Order of direct and indirect object*

The previous subsection has shown that weak proform shift cannot affect the unmarked order of the subject and the objects. This is different when it comes to the relative order of direct and indirect objects: while direct objects normally follow nominal indirect objects under a neutral intonation pattern, weak pronominal direct objects normally precede indirect objects. Example (181b) shows that this holds regardless of whether the indirect object is non-pronominal or pronominal. It should further be noted that it also holds if the two object pronouns have the same form: the first object pronoun in *dat Peter 'm 'm aanbood* 'that Peter offered it to him' is construed as the direct object.

- (181) a. dat Peter <\*de auto> Marie <de auto> aanbood.  
 that Peter the car Marie the car prt.-offered  
 'that Peter offered Marie the car.'
- b. dat Peter <'m> Marie/'r <?'m> aanbood.  
 that Peter him Marie/her prt.-offered  
 'that Peter offered it to Marie/her.'

Weak objects pronouns are always adjacent to each other, which may be due to the fact illustrated in the previous subsection that they must both be adjacent to the finite verb or the subject if it is not in clause-initial position; the only new thing is that this restriction does not hold for the individual pronouns but for the full cluster. It should also be noted that Haegeman (1993a) observes for W-Flemish that inversion of the indirect and direct object requires the indirect object to be scrambled. Example (182) shows that the same seems to hold in Dutch, although it should be noted that the degraded order improves if the indirect object is assigned contrastive accent.

- (182) dat Jan 't <Marie> waarschijnlijk <\*'Marie> gegeven heeft.  
 that Jan it Marie probably given has  
 'that Jan has probably given it to Marie.'

This reversal of the direct and the indirect objects is possible only with reduced direct objects. It is not easy, however, to demonstrate reversal for strong referential personal pronouns because they cannot be used to refer to inanimate entities. The examples in (183) therefore illustrate this reversal by means of the demonstrative *die* 'that one'; the judgments only hold under a non-contrastive intonation pattern.

- (183) a. dat Peter <?'die> Marie <die> aanbood.  
 that Peter DEM Marie prt.-offered  
 'that Peter offered Marie that one.'

- b. dat Peter <\*die> 'r <die> aanbod.  
 that Peter DEM her prt.-offered  
 'that Peter offered her that one.'

The fact that object pronouns can be inverted while non-pronominal nominal arguments cannot has given rise to the hypothesis that they do not occupy the same position in the middle field of the clause, since only weak pronouns undergo weak proform shift; cf. Zwart (1996). If we assume in addition that weak proform shift is similar to clitic movement in languages like French, this hypothesis can be supported by the fact that third person direct and indirect object clitics in French appear in the same order as in Dutch: *Jean le<sub>DO</sub> lui<sub>IO</sub> donnera* 'Jean will give it to him/her'. The fact discussed earlier that weak object pronouns cluster provides additional support to the hypothesis that they are clitic-like.

### 3. Order of subject and object in AcI-constructions

Subjects and direct objects of infinitival complement clauses in °AcI-constructions are indistinguishable as far as their morphological form is concerned: this holds not only for referential noun phrases but also for their pronominalized counterparts, as both appear as object pronouns. Nevertheless, the examples in (184a&b) show that weak proform shift of an embedded object can optionally cross the subject of the infinitival clause; cf. Zwart (1996). Example (184c) shows that this is in fact the preferred option if the subject is also realized as a weak pronoun. The acceptability of inversion shows that the restriction established above, namely that weak proform shift of objects cannot affect the unmarked order of subjects and objects, only holds if the subject is assigned nominative case.

- (184) a. Jan zag/liet <\*het boek<sub>theme</sub>> Marie<sub>agent</sub> <het boek<sub>theme</sub>> lezen.  
 Jan saw/let the book Marie read  
 'Jan saw/let Marie read the book.'
- b. Jan zag/liet <'t<sub>theme</sub>> Marie<sub>agent</sub> <'t<sub>theme</sub>> lezen.  
 Jan saw/let it Marie read
- c. Jan zag/liet <'t<sub>theme</sub>> 'r<sub>agent</sub> <??, t<sub>theme</sub>> lezen.  
 Jan saw/let it her read

The examples in (185) show that weak proform shift of an embedded direct object may also cross the subject if the infinitival clause is ditransitive: the direct object pronoun must cross the indirect object and optionally crosses the embedded subject.

- (185) a. Jan zag/liet <\*het boek<sub>theme</sub>> Els<sub>agent</sub> Peter<sub>goal</sub> <het boek<sub>theme</sub>> aanbieden.  
 Jan saw/let the book Els Peter prt. offer  
 'Jan saw/let Els offer Peter the book.'
- b. Jan zag/liet <'t<sub>theme</sub>> Els<sub>agent</sub> <'t<sub>theme</sub>> Peter<sub>goal</sub> <??, t<sub>theme</sub>> aanbieden.  
 Jan saw/let it Els Peter prt.-offer

It seems, however that weak embedded indirect object pronouns cannot cross the subject of the infinitival clause: according to us, (186b) can only be interpreted with the pronoun as an agent and *Els* as a goal. It seems plausible that the deviance of (186b) is related to the fact that the agent and the goal are both [+HUMAN].

- (186) a. Jan zag/liet <\*Peter<sub>goal</sub>> Els<sub>agent</sub> <Peter<sub>goal</sub>> het boek<sub>theme</sub> aanbieden.  
 Jan saw/let Peter Els the book prt. offer  
 'Jan saw/let Els offer Peter the book.'
- b. \*Jan zag/liet <'m<sub>goal</sub>> Els<sub>agent</sub> <'m<sub>goal</sub>> het boek<sub>theme</sub> aanbieden.  
 Jan saw/let him Els the book prt. offer  
 'Jan saw/let Els offer him the book.'

Something similar holds for cases in which both the direct and the indirect object surface as weak pronouns: examples such as (187b), which are given as fully acceptable in Zwart (1993/1996), are only acceptable to us if the pronoun 'm is interpreted as agent and *Els* as goal. The unacceptability of (187c) deserves special mention as it is unexpected in the light of the fact that (184c) is fully acceptable; the fact that weak object pronouns must be adjacent to each other again provides support to the hypothesis that they are clitic-like in that they obligatorily cluster.

- (187) a. Jan zag/liet Els<sub>agent</sub> 't<sub>theme</sub> 'm<sub>goal</sub> aanbieden.  
 Jan saw/let Els it him prt. offer  
 'Jan saw/let Els offer it to him.'
- b. \*Jan zag/liet 't<sub>theme</sub> 'm<sub>goal</sub> Els<sub>agent</sub> aanbieden.  
 Jan saw/let it him Els prt. offer
- c. \*Jan zag/liet 't<sub>theme</sub> Els<sub>agent</sub> 'm<sub>goal</sub> aanbieden.  
 Jan saw/let it Els him prt. offer

Example (188a) shows that if all the arguments of a ditransitive infinitival clause surface as weak pronouns they must occur in the order agent > theme > goal. It should be pointed out, however, that some speakers find a sequence of three weak pronouns difficult to pronounce and may therefore prefer the version in (188b) with a prepositional indirect object; in such cases the theme again preferably precedes the agent.

- (188) a. Jan zag/liet 'r<sub>agent</sub> 't<sub>theme</sub> 'm<sub>goal</sub> aanbieden.  
 Jan saw/let her it him prt. offer  
 'Jan saw/let her offer him the book.'
- b. Jan zag/liet <'t<sub>theme</sub>> 'r<sub>agent</sub> <'t<sub>theme</sub>> aan 'm<sub>goal</sub> aanbieden.  
 Jan saw/let it her her to him prt. offer  
 'Jan saw/let her offer it to him.'

Example (189) suggests that weak proform shift is able to feed °binding: while non-pronominal direct objects cannot bind a reciprocal indirect object, shifted direct object pronouns can.

- (189) dat Marie <ze<sub>theme</sub>> elkaar<sub>goal</sub> <\*de jongens<sub>theme</sub>> voorgesteld heeft.  
 that Marie them each.other the boys prt.-introduced has  
 'that Marie has introduced them to each other.'

Since feeding of binding is generally seen as a hallmark of A-movement, this may also suggest that weak proform shift is A-movement. It should be noted, however, that weak proform shift may be preceded by nominal argument shift and that it may be the case that this is responsible for feeding binding; cf. Haegeman (1993a/1993b).

We provisionally assume that weak proform shift of arguments is A'-movement because Subsection III will show that weak proforms that do not function as arguments may undergo a similar shift.

### C. Pronominal subjects of passive and unaccusative constructions

Section 2.1.2 has shown that derived subjects can either precede or follow an indirect object; this is illustrated again in (190a) by means of the passivized counterpart of the ditransitive construction *dat Jan Peter/'m de baan aanbood* 'that Jan offered Peter/him the job'. Example (190b) shows that the weak subject pronoun must precede the indirect object (which is not very surprising because strong subject pronouns are obligatorily moved into the regular subject position by nominal argument object shift; see 13.2, sub IB). The examples in (191) show the same for the dyadic unaccusative (NOM-DAT) verb *bevallen* 'to please'.

- (190) a. *dat <de baan> Peter/'m <de baan> aangeboden werd.*  
 that the job Peter/him prt.-offered was  
 'that the job was offered to Peter/him.'
- b. *dat <ie> Peter/'m <\*ie> aangeboden werd.*  
 that he Peter/him he prt.-offered was  
 'that it was offered to Peter/him.'
- (191) a. *dat <de film> Peter/'m <de film> bevallen is.*  
 that the movie Peter/him pleased is  
 'that the movie has pleased Peter/him.'
- b. *dat <ie> Peter/'m <\*ie> bevallen is.*  
 that he Peter/him he pleased is  
 'that it has pleased Peter/him.'

### 4. Conclusion

The previous subsections have shown that weak object pronouns cannot be moved across nominative subjects. At first sight, this would suggest that weak proform shift cannot affect the unmarked order of nominal arguments (agent > goal > theme), but this turns out not to be correct, as is clear from the fact that weak direct object pronouns preferably precede nominal indirect objects, and that they can also be moved across an embedded subject in an Acl-construction. That weak proform shift can affect the unmarked order of nominal argument shows that weak pronouns can occupy positions in the clause that are not accessible to their non-pronominal counterparts, which in turn gives credence to the hypothesis that they are clitic-like. This hypothesis is further supported by the fact that weak object pronouns obligatorily cluster together.

Weak subject and object pronouns exhibit various properties often attributed to clitics. The examples in (192) show, for example, that they cannot be used as independent utterances and cannot be topicalized or coordinated; see Haegeman (1993b) for relevant discussion. Zwart (1996) notes, however, that these properties also hold for the English reduced pronouns, which behave syntactically as regular pronouns, and concludes from this that they are not defining characteristics of clitics but simply follow from the fact that weak pronouns cannot be accented.



- (192) a. Wie heb je gezien? Hem/\*'m.  
 who have you seen him/him  
 b. Hem/\*'m heb ik niet gezien.  
 him/him have I not seen  
 'Him, I haven't seen.'  
 c. [hem en haar]/\*['m en 'r]  
 him and her him and her

A potential problem for the claim that Dutch weak pronouns are clitics is that they differ from run-of-the-mill clitics in that they are not hosted by a verb. A related problem is that they can occur in PPs: *bij 'm* 'with him'; cf. Haegeman (1993b). The hypothesis that Dutch weak pronouns are clitics thus requires there to be some (phonetically empty) functional head that they can cliticize to. Currently, there does not seem to be a generally accepted analysis available but the tentative proposals in Haegeman (1993a/1993b) and Zwart (1993/1996) do agree on the fact that the prospective functional head(s) have nominal (case or agreement) features. We leave this claim for future research.

## II. The simplex reflexive *zich*

Section N5.2.1.5 has shown that Dutch has two types of reflexive pronouns: simplex reflexive pronouns such as third person *zich* and complex ones such as third person *zichzelf* 'him/herself/themselves'. Simplex reflexive pronouns differ from complex ones in that they must precede modal adverbs such as *waarschijnlijk* 'probably'; cf. Huybregts (1991). We refer the reader to N5.2.1.5 for a more extensive discussion of these two forms.

- (193) a. Marie heeft <zichzelf> waarschijnlijk <zichzelf> aan Jan voorgesteld.  
 Marie has herself probably to Jan prt.-introduced  
 'Marie has probably introduced herself to Jan'  
 b. Marie heeft <zich> waarschijnlijk <\*>zich> voorgesteld aan Jan.  
 Marie has REFL probably prt.-introduced to Jan  
 'Marie has probably introduced herself to Jan.'

Simplex reflexive pronouns behave like object pronouns in that they cannot precede subject pronouns. We illustrate this in (194) by means of a number of strong singular referential personal pronouns; the judgments do not change if we replace the strong subject pronouns by their weak counterparts.

- (194) a. dat <\*>me> ik <me> nog niet heb voorgesteld.  
 that REFL I yet not have prt.-introduced  
 'that I haven't introduced myself yet.'  
 b. dat <\*>je> jij <je> nog niet hebt voorgesteld.  
 that REFL you yet not have prt.-introduced  
 'that you haven't introduced yourself yet.'  
 c. dat <\*>zich> zij <zich> nog niet heeft voorgesteld.  
 that REFL she yet not has prt.-introduced  
 'that she hasn't introduced herself yet.'

Simplex reflexive pronouns are special, however, in that they normally precede non-specific indefinite and negative subject pronouns, which we illustrate in (195) by means of expletive-*there* constructions; cf. Haeseryn et al. (1997:1314). This means that they differ from object pronouns, which can never be moved across the subject of their clause but instead push the subject up into the regular subject position: see Section 13.2, sub IC1, for discussion.

- (195) a. dat er <zich> drie vaten bier <\*zich> in de kelder bevinden.  
 that there REFL three barrels [of] beer in the cellar are.located  
 ‘There are three barrels of beer in the cellar.’  
 b. dat er <zich> een meisje <\*zich> in de kelder opgehangen heeft.  
 that there REFL a girl in the cellar prt.-hanged has  
 ‘that a girl has hanged herself in the cellar.’

With respect to specific indefinite and generic subject pronouns simplex reflexive pronouns again behave like object pronouns in that they follow them; cf. Haeseryn et al. (1997:1314).

- (196) a. dat <\*zich> een vriendin van hem <zich> in de kelder opgehangen heeft.  
 that REFL a friend of him in the cellar prt.-hanged has  
 ‘that a lady friend of his has hanged herself in the cellar.’  
 b. dat <\*zich> een puber <zich> nu eenmaal zo gedraagt.  
 that REFL an adolescent PRT PRT like.that behaves  
 ‘that an adolescent will behave like that.’

The ordering with respect to definite subjects seems to be relatively free, as is clear from example (197b). The placement of the subject in this example seems to be determined by the information structure of the clause: it follows the reflexive if it is part of the new information of the clause, while it precedes the reflexive if it is part of the presupposition; cf. Haeseryn et al. (1997:1315).

- (197) a. dat er zich hier een drama heeft afgespeeld.  
 that there REFL here a tragedy has prt.-played  
 ‘that a tragedy took place here.’  
 b. dat <dat drama> zich hier <dat drama> afgespeeld heeft.  
 that that tragedy REFL here prt.-played has  
 ‘that that tragedy took place here.’

This is consistent with the observation in Haeseryn et al. that the order reflexive–subject is found especially with inherently reflexive predicates that denote a process of appearing or coming into existence. Some examples are given in (198).

- (198) a. In de verte verhieven zich de Alpen.  
 in the distance rose REFL the Alps  
 ‘In the distance rose the Alps.’  
 b. Er dienen zich twee problemen aan.  
 there present REFL two problems prt.  
 ‘Two problems present themselves.’

- c. Er tekende zich een kleine meerderheid af.  
 there silhouetted REFL a small majority prt.  
 ‘A small majority became apparent.’

The ordering *vis-a-vis* negative subjects also has a semantic effect: while (199) expresses that there are no registrations at all, example (199b) does not necessarily imply this but may also be used to express that no individual from a *contextually defined* set has registered; cf. Haeseryn et al. (1997:1315).

- (199) a. dat zich nog niemand heeft aangemeld.  
 that REFL yet nobody has prt.-registered  
 ‘that nobody has registered yet.’  
 b. dat niemand zich nog heeft aangemeld.  
 that nobody REFL yet has prt.-registered  
 ‘that nobody has registered yet.’

In some cases it is virtually impossible for the reflexive pronoun to precede the subject; in (200) the simplex reflexive must follow the negative subject even though this means that it cannot be shifted across the modal adverb; cf. (193b). The acceptability contrast indicated is confirmed by the fact that a Google search (7/14/2015) on the string [*zich niemand herinnert*] resulted in no more than five relevant examples from the 19<sup>th</sup> century, while the alternative order resulted in 48 hits. It is not yet clear what determines precisely whether the order reflexive pronoun–subject is possible or not, although it is conspicuous that all examples given in Haeseryn et al. (1997) involve intransitive inherently reflexive verbs.

- (200) a. dat (waarschijnlijk) niemand zich die man herinnert.  
 that probably nobody REFL that man remembers  
 ‘that probably nobody remembers that man.’  
 b. ??dat zich (waarschijnlijk) niemand die man herinnert.  
 that REFL probably nobody that man remembers

In transitive constructions, the relative order of weak object and simplex reflexive pronouns seems to be relatively free, although there is a clear preference for the former to precede the latter. We checked this for the pronoun *het* ‘it’, which is virtually always weak in speech, by doing a Google search (7/14/2015) on the search strings [*het zich (niet) herinnert*] and [*zich het (niet) herinnert*].

- (201) a. dat Jan ’t zich (niet) herinnert. [207 hits]  
 that Jan it REFL not remembers  
 ‘that Jan remembers it/that Jan doesn’t remember it.’  
 b. dat Jan zich ’t (niet) herinnert. [36 hits]  
 that Jan REFL it not remembers  
 ‘that Jan remembers it/that Jan doesn’t remember it.’

For completeness’ sake, it should be noted that the preferred Dutch order differs from the one found in French, where the reflexive clitic precedes the object clitic: cf. *Il se le rappelle* ‘He remembers it’.

### III. The weak R-word *er*

The phonetically weak R-word *er* has the four distinctive functions illustrated in (202). Expletive *er* normally introduces some indefinite subject (cf. N8.1.4) but also occurs in impersonal passives (cf. 3.2.1.2), locational *er* refers to some contextually defined location, prepositional *er* represents the nominal part of a pronominalized PP (cf. P5), and quantitative *er* is associated with an interpretative gap [*e*] in a quantified noun phrase (cf. N6.3). Sometimes a single occurrence of *er* expresses more than one function, but this will be ignored here; see Section P.5.5 for extensive discussion.

- (202) a. dat <er> waarschijnlijk <\*er> iemand ziek is. [expletive]  
 that there probably someone ill is  
 'that there is probably someone ill.'
- b. dat Jan <er> waarschijnlijk <\*er> geweest is. [locational]  
 that Jan there probably been is  
 'that Jan has probably been there.'
- c. dat Jan <er> waarschijnlijk <?er> over wil praten. [prepositional]  
 that Jan there probably about wants talk  
 'that Jan probably wants to talk about it.'
- d. dat Jan <er<sub>i</sub>> waarschijnlijk <\*er<sub>i</sub>> [twee/veel [e<sub>i</sub>]] heeft. [quantitative]  
 that Jan there probably two/many has  
 'that Jan probably has two/many of them.'

This subsection will focus on the distribution of the various types within the clause. The examples in (202) already show that all types resemble weak pronouns in that they normally precede modal adverbs such as *waarschijnlijk* 'probably'. Details concerning their placement will be discussed in separate subsections.

#### A. Expletive *er*

The distribution of expletive *er* is identical to that of (weak) subject pronouns: in main clauses it immediately precedes or follows the finite verb and in embedded clauses it immediately follows the complementizer (if overtly realized). It is therefore not surprising that it is often assumed that expletive *er* is located in the regular subject position, that is, the specifier of TP. Putting aside cases in which expletive *er* occupies the sentence-initial position, this correctly predicts that it is always the leftmost element in the middle field of the clause.

- (203) a. Er komt morgen waarschijnlijk een vriend van hem op visite.  
 there comes tomorrow probably a friend of his on visit  
 'There is probably a friend of his coming to visit us tomorrow.'
- a'. Morgen komt er waarschijnlijk een vriend van hem op visite.  
 tomorrow comes there probably a friend of his on visit  
 'Tomorrow there is probably a friend of his coming to visit us.'
- b. dat er morgen waarschijnlijk een vriend van hem op visite komt.  
 that there tomorrow probably a friend of his on visit comes  
 'that there is probably a friend of his coming to visit us tomorrow.'

*B. Locational er*

Locational *er* differs from other locational proforms in that it must precede the modal adverbs. The (a)-examples in (204) illustrate this for an adverbial phrase, and the (b)-examples for a complementive. Observe that the locational R-word *daar* can also be moved across the modal adverb; we return to this in Subsection C.

- (204) a. dat Jan waarschijnlijk in de speeltuin speelt. [adverbial]  
 that Jan probably in the playground plays  
 ‘that Jan is probably playing in the playground.’
- a'. dat Jan <daar/er> waarschijnlijk <daar/\*er> speelt.  
 that Jan there/there probably plays  
 ‘that Jan is probably playing there.’
- b. dat Jan waarschijnlijk in de speeltuin geweest is. [complementive]  
 that Jan probably in the playground been is  
 ‘that Jan has probably been in the playground.’
- b'. dat Jan <daar/er> waarschijnlijk <daar/\*er> geweest is.  
 that Jan there/there probably been is  
 ‘that Jan has probably been there.’

The examples in (205) show that location *er* resembles the French locative clitic *y* in that it follows weak object pronouns: cf. *Je les y ai vus* ‘I have seen them there’.

- (205) a. dat ik ze er gezien heb.  
 that I them there seen have  
 ‘that I have seen them there.’
- b. \*dat ik er ze gezien heb.  
 that I there them seen have

*C. Prepositional er*

Pronominal PPs functioning as an argument of the verb can be split; movement of heavier R-words such as *daar* is optional, while movement of the weak form *er* is greatly preferred. The two parts of the pronominal PP are in italics.

- (206) a. dat Jan waarschijnlijk over dat probleem wil praten.  
 that Jan probably about that problem wants talk  
 ‘that Jan probably wants to talk about that problem.’
- b. dat Jan <daar> waarschijnlijk [<sub>PP</sub> <daar> over] wil praten.  
 that Jan there probably about wants talk  
 ‘that Jan probably wants to talk about that.’
- c. dat Jan <er> waarschijnlijk [<sub>PP</sub> <<sup>?</sup>er> over] wil praten.  
 that Jan there probably about wants talk  
 ‘that Jan probably wants to talk about it.’

The fact that *daar* and *er* can both be moved leftward, which was also observed in the previous subsection for locational proforms, can perhaps be taken as evidence against the claim that *er* is clitic-like by assuming that the ability to undergo leftward movement is simply a more general property of R-words. Indeed, it has been suggested that there is a designated [+R]-position in the functional domain of

the clause that serves as a landing site for R-words; cf. Van Riemsdijk (1978). The examples in (207) show, however, that it is possible to shift two R-words in a single clause as long as they are not both weak or both strong.

- (207) a. dat Jan *er* hier waarschijnlijk niet *over* wil praten.  
 that Jan there here probably not about wants talk  
 ‘that Jan probably doesn’t want to talk about it here.’
- b. \*dat Jan *er er* waarschijnlijk niet *over* wil praten  
 that Jan there there probably not about wants talk  
 ‘that Jan probably doesn’t want to talk about it here.’
- c. ??dat Jan *daar* hier waarschijnlijk niet *over* wil praten.  
 that Jan there here probably not about wants talk  
 ‘that Jan probably doesn’t want to talk about it here.’

Huybregts (1991) concluded from this that there are actually *two* [+R]-positions, one of which is accessible to weak R-words only. If correct, this shows that it is possible to identify a designated position for the weak R-word *er* after all, as required by the hypothesis that *er* is clitic-like. We will not digress on this here, but refer to reader to Section P5.5 for a detailed discussion of Huybregts’ proposal.

The examples in (208) show that while prepositional *er* is able to precede non-pronominal objects, it must follow weak object pronouns.

- (208) a. Jan heeft zijn kinderen tegen ongewenste invloeden beschermd.  
 Jan has his children against undesirable influences protected  
 ‘Jan has protected his children against undesirable influences.’
- a’. Jan heeft <*er*> zijn kinderen <*er*> tegen beschermd.  
 Jan has there his children against protected  
 ‘Jan has protected his children against them.’
- a''. Jan heeft <\**er*> ze <*er*> tegen beschermd.  
 Jan has there them against protected
- b. Marie heeft Peter tot diefstal gedwongen.  
 Marie has Peter to theft forced  
 ‘Marie has forced Peter to steal.’
- b’. Marie heeft <*er*> Peter <*er*> toe gedwongen.  
 Marie has there Peter to forced  
 ‘Marie has forced Peter to do it.’
- b''. Marie heeft <\**er*> ’m <*er*> toe gedwongen.  
 Marie has there him to forced

#### D. Quantitative *er*

Quantitative *er* is associated with an interpretative gap within a quantified nominal argument which can be filled in on the basis of contextual information. While Peter is looking for a pan, the speaker may tell him how to obtain one by means of the utterances in (209a&b). Example (209c) likewise implies that there is a contextually defined set of individuals (say, students) who are given a book.

- (209) a. Er staan  $er_i$  waarschijnlijk [<sub>NP</sub> twee [ $e_i$ ]] in de keuken. [subject]  
 there stand there probably two in the kitchen  
 ‘There are probably two [pans] in the kitchen.’
- b. Jan heeft  $er_i$  waarschijnlijk [<sub>NP</sub> drie [ $e_i$ ]] op tafel gezet. [direct object]  
 Jan has there probably three on table put  
 ‘Jan has put three [pans] on the table.’
- c. Jan gaf  $er_i$  waarschijnlijk [<sub>NP</sub> één [ $e_i$ ]] een boek. [indirect object]  
 Jan gave there probably one a book  
 ‘Jan probably gave one [student] a book.’

The examples in (209) show that quantitative *er* is obligatorily placed in front of the modal adverb and follows the finite verb in subject-initial clauses. If the subject is located in the middle field, as in (210), quantitative *er* follows the subject even if the subject follows a modal adverb.

- (210) a. dat Jan  $er_i$  waarschijnlijk [<sub>NP</sub> één [ $e_i$ ]] heeft.  
 that Jan there probably one has  
 ‘that Jan probably has one.’
- b. dat waarschijnlijk niemand  $er_i$  [<sub>NP</sub> één [ $e_i$ ]] heeft.  
 that probably nobody there one has  
 ‘that probably nobody has one.’

When we consider the relative order of quantitative *er* and weak object pronouns, at least three cases should be distinguished; this will be discussed in the following subsections.

### 1. *The associate noun phrase is a subject*

If the associate of quantitative *er* is a subject, a weak direct object pronoun must follow the associate, and even then the result is somewhat marked, which we indicate here by means of a question mark. This is shown in (211b), on the basis of the clause *dat vier studenten het boek gelezen hebben* ‘that four students have read the book.’

- (211) a. dat  $er_i$  [<sub>NP</sub> vier [ $e_i$ ]] het boek gelezen hebben.  
 that there four the book read have
- b. dat <\*'t>  $er_i$  <\*'t> [<sub>NP</sub> vier [ $e_i$ ]] <?'t> gelezen hebben.  
 that it there four read have

Example (212b) shows that the same holds for weak indirect object pronouns, on the basis of the clause *dat twee studenten Peter het boek aangeboden hebben* ‘that two students have offered Peter the book’. For completeness’ sake, the (c)-examples show that the direct and indirect pronouns must appear after the associate; although the primeless (c)-example is somewhat marked itself, the contrast with the primed ones is quite sharp.



- (212) a. dat  $er_i$  [<sub>NP</sub> twee [ $e_i$ ]] Peter het boek aangeboden hebben.  
 that there two Peter the book prt.-offered have
- b. dat  $er_i$  <\*'m> [<sub>NP</sub> twee [ $e_i$ ]] <?'m> het boek aangeboden hebben.  
 that there him two the book prt.-offered have
- c. ?dat  $er_i$  [<sub>NP</sub> twee [ $e_i$ ]] 't 'm aangeboden hebben.  
 that there two it him prt.-offered have
- c'. \*dat  $er_i$  't [<sub>NP</sub> twee [ $e_i$ ]] 'm aangeboden hebben.  
 that there it two him prt.-offered have
- c''. \*dat  $er_i$  't 'm [<sub>NP</sub> twee [ $e_i$ ]] aangeboden hebben.  
 that there it him two prt.-offered have

### 2. The associate noun phrase is a direct object

Example (213a) shows that quantitative *er* may either precede or follow the indirect object. This is not entirely optional, however, as the (b)-examples bear out that the choice is partly determined by the surface position of the indirect object. Example (213b) shows that if the indirect object surfaces after the modal verb, the shift of quantitative *er* is indeed optional, although it should be noted that the shift must cross the modal adverb. Example (213c) shows that if the indirect object has undergone nominal argument shift, weak proform shift must apply as well although it may end up either preceding or following the indirect object.

- (213) a. Marie heeft < $er_i$ > Jan < $er_i$ > [<sub>NP</sub> één [ $e_i$ ]] gegeven.  
 Marie has there Jan one given  
 'Marie has given Jan one.'
- b. Marie heeft < $er_i$ > waarschijnlijk <\* $er$ > Jan < $er_i$ > [<sub>NP</sub> één [ $e_i$ ]] gegeven.  
 Marie has there probably Jan one given
- c. Marie heeft < $er_i$ > Jan < $er_i$ > waarschijnlijk <\* $er_i$ > [<sub>NP</sub> één [ $e_i$ ]] gegeven.  
 Marie has there Jan probably one given

While the examples in (213) show that quantitative *er* may either precede or follow a non-pronominal indirect object, there may be a preference for it to follow weak indirect object pronouns, although Haeseryn et al. (1997:1321) take both orders to be fully acceptable; note that the /d/ in (214b) is a linking sound that is inserted to break the sequence of two schwa's. If this preference is indeed significant, we should conclude that quantitative *er* behaves similarly in this respect to the French partitive clitic *en*: cf. *Je lui en ai donné une* 'I have given him one'.

- (214) a. Jan heeft <?' $er_i$ > 'm < $er_i$ > [<sub>NP</sub> één [ $e_i$ ]] gegeven.  
 Jan has there him one given  
 'Jan has given him one.'
- b. Ik heb <?' $er_i$ > ze <(d) $er_i$ > [<sub>NP</sub> een paar [ $e_i$ ]] gegeven.  
 I have there them a couple given  
 'I've given them a couple.'

### 3. The associate noun phrase is an indirect object

It is hard to construct cases with a weak indirect object pronoun. It seems that the pronoun preferably precedes quantitative *er*. We illustrate this in (215) for the

sentence *dat ik twee studenten het boek heb aangeboden* ‘that I have offered the book to two students’.

- (215) a. dat ik er<sub>i</sub> [<sub>NP</sub> twee [e<sub>i</sub>]] het boek heb aangeboden  
 that I there two the book have prt.-offered  
 b. <sup>??</sup>dat ik er<sub>i</sub> [<sub>NP</sub> twee [e<sub>i</sub>]] 't heb aangeboden.  
 that I there two it have prt.-offered  
 b'. \*dat ik er<sub>i</sub> 't [<sub>NP</sub> twee [e<sub>i</sub>]] heb aangeboden.  
 that I there it two have prt.-offered  
 b''. <sup>?</sup>dat ik 't er<sub>i</sub> [<sub>NP</sub> twee [e<sub>i</sub>]] heb aangeboden.  
 that I it there two have prt.-offered

#### IV. Conclusion

The previous subsections have shown that there are grounds for assuming that weak proforms are clitic-like. The first and foremost reason is that weak proforms are like clitics in that they cluster together. Furthermore, there are certain similarities in the relative order of weak proforms and, e.g., French clitics. This holds especially for weak object pronouns. First, weak proform shift inverts the order of third person indirect and direct objects, just like clitic placement in French. Second, weak object pronouns precede most other weak proforms, as do the object clitics in French. The only difference involves the reflexive forms: reflexive clitics precede object clitics while simplex reflexive *zich* tends to follow the weak object pronouns. Another reason not yet mentioned is that weak proform shift is clause-bound: it is never possible to move a weak proform out of its minimal finite clause (cf. Huybregts 1991). A conspicuous difference between clitics and weak proforms is that the former normally attach to a verbal host while the latter do not: with the exception of the simplex reflexive *zich* the Dutch proforms must follow the (nominative) subject. It should also be noted that the location of the subject is immaterial:

- (216) a. dat Jan 't waarschijnlijk gekocht heeft.  
 that Jan it probably bought has  
 ‘that Jan has probably bought it.’  
 b. dat <\*'t> waarschijnlijk Jan <'t> gekocht heeft  
 that it probably Jan bought has  
 ‘that Jan has probably bought it.’  
 b'. dat <\*'t> waarschijnlijk niemand <'t> gekocht heeft  
 that it probably nobody bought has  
 ‘that probably nobody has bought it.’

If we adopt the conclusions from Section 13.2 and 13.3.1 that the subjects in the examples in (216) occupy different positions, we must conclude that there is no fixed target position for weak proform shift either, which may be a potential problem for claiming that weak proform shift and clitic placement are virtually the same operation. We leave this issue to future research.

### **13.5. Bibliographical notes**

The fact that Dutch has a relatively free word order in the middle field of the clause has received a lot of attention in pre-generative frameworks: see Haeseryn et al. (1997:ch.21) for a good descriptive review of the findings of this research. This fact was also noted early in generative research (cf. Kerstens 1975), although it took some time before it was realized that the attested word order variation is not the result of a single generic scrambling rule, but of several different kinds of movement. A first step towards realizing this was the discovery in Van den Berg (1978) and De Haan (1979) that nominal argument shift, which was discussed in Section 13.2, plays an important role in demarcating a division between the presupposition and the focus of the clause, that is, between discourse-old and discourse-new information; we refer the reader to Section N8.4 for more references to the literature on nominal argument shift since then.

The claim that nominal argument shift (A-scrambling) should be distinguished from the various types of A'-scrambling discussed in section 13.3 was forcefully defended by Neeleman (1994a/1994b). A further forward momentum in generative research was Haegeman's work on negation movement; this research culminated in Haegeman (1995), which argued that at least some kinds of clause-internal movement are semantically motivated and, following earlier work by Rizzi (1996), also provided a general theoretical framework in which A'-scrambling could be investigated. Unfortunately, research on A'-scrambling took off slowly, and most of the results reached so far are controversial. For example, it is not yet clear whether the various types of A'-scrambling target a specific designated position, as would be predicted by Haegeman's framework, or whether they involve free °adjunction curtailed by various general restrictions, as claimed by Neeleman & Van de Koot (2008). Nor is it clear whether the various types of A'-scrambling apply obligatorily, a possibility suggested by Haegeman (1995) and defended by Barbiers (2010/2014) for Dutch focus movement, or whether they are essentially optional, as claimed by Neeleman & Van de Koot (2008) on the basis of English contrastive focus constructions.

The fact discussed in Section 13.4 that weak proforms are normally located in the left periphery of the middle field of the clause (immediately following the subject if it is not clause-initial) is also widely recognized; cf. Huybregts (1991) for a good overview of their syntactic behavior. However, theoretically orientated research on this issue is limited and, again, has not yet resulted in a generally accepted analysis; see Haegeman (1993a/1993b) and Zwart (1993/1996) for partly compatible proposals.



# **Chapter 14**

## **Main-clause external elements**

<b>Introduction</b>	<b>1680</b>
<b>14.1. Pragmatic markers</b>	<b>1682</b>
<b>14.2. Left dislocation</b>	<b>1691</b>
<b>14.3. Right dislocation</b>	<b>1714</b>
<b>14.4. Bibliographical notes</b>	<b>1733</b>

**Introduction**

This chapter takes as its point of departure the discussion in 9.2, which has shown that finite verbs can be found in basically two positions: the clause-final position in embedded clauses and the verb-first/second position in main clauses; the latter position is normally occupied by a complementizer in embedded clauses.

- (1) a. Marie zegt [dat Jan het boek op dit moment *leest*].  
 Marie says that Jan the book at this moment reads  
 ‘Marie says that Jan is reading the book at this moment.’
- b. Op dit moment *leest* Jan het boek.  
 at this moment reads Jan the book  
 ‘At this moment, Jan is reading the book.’

On the basis of these two positions, the clause can be divided into various “topological” fields: the clause-initial position, the middle field and the postverbal field; cf. representation (2).

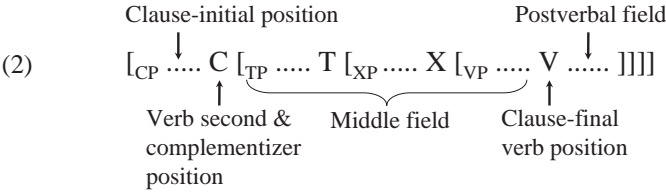

Chapter 11 has shown that the C-position can be preceded by at most one constituent. Nevertheless there are cases, like those given in example (3), in which this position is preceded by a second phrase. If the structure of the clause postulated in (2) is indeed correct, we have to conclude that the italicized phrases preceding the clause-initial position are clause-external. This seems supported by the fact that these phrases can be set apart from the sentence by a distinct intonation break.

- (3) a. *Ja*, dat wist ik al. [polar *yes/no*]  
 yes that knew I already  
 ‘Yes, I already knew that.’
- b. *Jan*, er is telefoon voor je. [vocative]  
 Jan there is phone.call for you  
 ‘Jan, there’s a phone call for you.’
- c. *Lieve help*, hij is ziek. [interjection]  
 good grief, he is ill  
 ‘Good grief, he’s ill!’

That the italicized phrases in (3) are clause-external is also suggested by the fact that they occur in root contexts only; cf. Riemsdijk & Zwarts (1997). The examples in (4), for instance, are excluded on the intended reading; the number signs indicate that vocatives and interjections can sometimes be used as parentheticals (if preceded and followed by an intonation break) but such cases are equivalent to cases in which they precede the full sentence, which shows that they should be construed with the main and not with the embedded clause.

- (4) a. Hij hoorde <\*ja> dat <\*ja> ik dat al wist.  
 he heard yes that I that already knew  
 ‘He heard that I knew that already.’
- b. Ik vermoed <<sup>#</sup>Jan> dat <\*Jan> er telefoon voor je is.  
 I suspect Jan that there phone.call for you is  
 ‘I suspect that there’s a phone call for you.’
- c. Marie ontkende <<sup>#</sup>lieve help> dat <\*lieve help> hij ziek is.  
 Marie denied good grief that he ill is  
 ‘Marie denied that he is ill.’

The examples in (3) and (4) suggest that polar *ja/nee*, vocatives and interjections are not only extra-clausal but even extra-sentential: they can also occur without an accompanying clause under the proper extra-linguistic circumstances: *ja/nee* suffices as an answer to a *yes/no*-question, vocatives can simply be used to attract attention, and interjections such as *Lieve help!* can be used in response to the occurrence of eventualities with certain undesirable qualities.

- (5) a. Heb je even tijd voor me? Nee. [answer to *yes/no*-question]  
 have you a.moment time for me no  
 ‘Do you have a moment for me? No.’
- b. Jan! [call for attention]
- c. Lieve help! [exclamation]

Since the italicized phrases in (3) may be extra-sentential, it is not clear whether they should be dealt with in a work on syntax. These elements instead seem to play an important role in discourse, e.g., by drawing the attention of discourse participants (vocatives and certain interjections) and by expressing emotions (the interjection *Lieve help!*). Discourse chunks such as (6) further show that such elements play an important role in structuring discourse by regulating turn-taking; the extra-sentential element *toch* is used for requesting feedback and *ja* provides a response to this request. The extra-sentential elements discussed so far are often referred to as PRAGMATIC MARKERS in order to express that they are generally assumed to be the subject matter of theories on language use.

- (6) Jan is al weg, toch? Ja, dat klopt. [turn-taking]  
 Jan is already away PRT yes that is.right  
 ‘Jan has left, hasn’t he? Yes, that’s right.’

It should be noted, however, that certain extra-sentential elements have been considered by syntacticians for a long time. This holds especially for so-called left-dislocation constructions as illustrated in the (a)-examples in (7), in which a sentence-external phrase is resumed by a demonstrative in clause-initial position or a referential pronoun in the middle field of the clause; the intended reading is indicated by means of indices. For phrases following the clause the same holds: these are often not discussed in syntactic work with the exception of right-dislocated phrases such as given in (7b), which have a correlate in the preceding clause.



- (7) a. Peter<sub>i</sub>, die<sub>i</sub> heb ik gisteren gezien. [left dislocation]  
 Peter DEM have I yesterday seen  
 ‘Peter, I saw him yesterday.’
- a’. Peter<sub>i</sub>, ik heb hem<sub>i</sub> gisteren gezien. [left dislocation]  
 Peter I have him yesterday seen  
 ‘Peter, I saw him yesterday.’
- b. Ik heb hem gisteren gezien, Peter. [right dislocation]  
 I have him yesterday seen Peter  
 ‘I saw him yesterday, Peter.’

Left- and right-dislocated phrases differ from the extra-sentential phrases of the type mentioned earlier in that they do not primarily have a pragmatic function, but instead play an important role in shaping the information structure of utterances. Given that this work is not concerned with the actual use of utterances, the focus of this chapter will be on left- and right-dislocated phrases, which will be discussed in Section 14.2 and 14.3, respectively. For completeness’ sake, however, Section 14.1 briefly addresses a number of extra-sentential pragmatic markers.

### 14.1. Pragmatic markers

This section discusses a number of prototypical cases of extra-sentential pragmatic markers. We will see that these markers may have a quite different syntactic status: they may be lexical items, phrases and even clauses. These markers do not seem to have clear truth-conditional content but instead perform a wide range of pragmatic functions; they are indexical in that they point to some aspect of the discourse: the addressee, states of affairs occurring during discourse and earlier statements, the speaker’s assumptions, intentions, emotions, etc.

Pragmatic markers are generally highly conventionalized, as is clear from the fact that Haeseryn et al. (1997:ch.11) provides a long list of such markers with their conventional pragmatic value. Example (8) provides a small selection of these cases; the subsections below will modify the characterization of some of the pragmatic functions given in (8), but this need not concern us here.

- (8) disapproval – *foei!* ‘shame!’; affirmation – *ja(wel)* ‘yes’; denial – *(wel) nee* ‘no’; doubt – *tja* ‘well’; indifference; *nou en?* ‘so what?’; agreement – *oké* ‘O.K.’; inducement – *toe nou!* ‘come on!; curse – *barst!* ‘go to hell!’; request for clarification/repetition – *hè/sorry?*; request for confirmation – *nietwaar?* (with a meaning comparable to English tag questions); salutations: *goeiedag/hoi!* ‘good day/hey!’; apologies – *pardon* ‘sorry’; expression of emotion like *goddank* ‘thank god’ (relief), *sjonge* ‘well’ (surprise), *hoera* ‘hooray’ (joy); etc.

We will briefly discuss some of these functions in the following subsection for further clarification. Subsection I starts by discussing pragmatic markers that can be used for addressing some (potential) discourse participant or calling their attention. Subsection II discusses a specific set of pragmatic markers that help to organize the discourse by relating utterances to some earlier or later utterance (or state of affairs), accommodate turn-taking, etc. Subsection III discusses a set of pragmatic

markers used for responding to previous utterances, that is, answering, confirming, contradicting, etc. Subsection IV concludes with a discussion of pragmatic markers that are used for expressing the speaker's emotions.

### 1. Addressing and drawing attention

Proper names such as *Jan* are typically used for addressing people, but the same holds for nouns indicating kinship relations or professions; see N5.1.2.2 for details. The examples in (9) show that such vocatives do not have to precede the sentence, but can also follow it.

- (9) a. Jan, kan je me even helpen?  
 Jan can you me a.moment help  
 'Jan, can you help me a moment, please?'  
 a'. Kan je me even helpen, Jan?  
 b. Papa/Dokter, wilt u een koekje?  
 daddy/doctor want you a biscuit  
 'Daddy/Doctor, would you like a biscuit.'  
 b'. Wilt u een koekje, Papa/dokter?

There is no immediate reason for assuming that vocatives are syntactically connected to the sentence, as they can also be used as independent utterances, e.g., when they are used to call someone: *Jan!* That vocatives are not syntactically connected to the sentence is also clear from the fact that they cannot °bind reflexive pronouns, which must have an antecedent within their minimal clause.

- (10) \*Jan<sub>i</sub>, ik heb zichzelf<sub>i</sub> gezien.  
 Jan I have himself seen

In this respect they are similar to salutations (*hoi* 'hi'), interjections (*hé!* 'hey!') and hesitation markers (*eh* 'er'), which can likewise be used as independent utterances. It should be noted, however, that there is a word order restriction regarding interjections and vocatives in that the former must precede the latter. It is not clear whether this shows that vocatives are more intimately related to the following sentence, as the independent uses of *Hey, Jan!* and *Eh, Jan?* exhibit a similar word order restriction.

- (11) a. Hé, Jan, kan je me even helpen?  
 hey Jan can you me a.moment help  
 'Hey, Jan, can you help me a moment?'  
 b. Eh, Jan, kan je me even helpen?  
 er Jan can you me a.moment help  
 'Er, Jan, can you help me a moment, please?'

It is not the case that vocatives are always closest to the following sentence; the examples in (12) show that they can be preceded or followed by phrases such as *zeg/kijk (eens)*, which are likewise used for drawing attention.

- (12) a. Zeg (eens), Jan, kan je me even helpen?  
 say PRT Jan can you me a.moment help  
 ‘Hey, Jan, can you help me a moment?’  
 a’. Jan, zeg (eens), kan je me even helpen?  
 b. Kijk (eens), Jan, daar loopt een eekhoorn!  
 look PRT Jan there walks a squirrel  
 ‘Look, Jan, there is a squirrel over there!’  
 b’. Jan, kijk (eens), daar loopt een eekhoorn!

It should be pointed out, however, that the structure of the examples in (12) is not very clear. First, note that *zeg/kijk (eens)* appears to be a regular imperative clause, which is clear from the fact that at least *kijk (eens)* can also be used as an independent utterance: this suggests that we might be dealing with two juxtaposed clauses. If so, the vocatives in the primed examples may belong to the imperative, as is in fact also suggested by the acceptability of *Jan, kijk eens!*. It is therefore not so obvious that the primed examples show that vocatives can be separated from their associate sentences by other extra-sentential elements. The primeless examples are potentially ambiguous for the same reason, as the vocatives can be construed either with the preceding imperative or with the following interrogative/declarative clause.

The discussion above has shown that elements used for addressing and drawing attention can often be used independently. Despite the orthographic convention of using a comma, we might therefore be dealing with separate utterances or, alternatively, with some sort of juxtaposition.

## II. Organization of the discourse

One of the prototypical functions of sentence-external pragmatic markers is that they help in organizing the discourse by pointing to some earlier statement or some state of affairs. Diewald (2009) distinguishes two different kinds, which she refers to as text-connective and discourse markers, respectively.

### A. Text-connective markers

Coordinating conjunctions like *en* ‘and’, *maar* ‘but’, and *dus* ‘therefore’ can be used as text-connective markers. These elements are quite common in the initial position of an utterance but it is questionable that they are really sentence-external: we may simply be dealing with a coordinate structure, with the first conjunct left implicit: [[Ø] conjunction [clause]]. The speaker may leave the first conjunct implicit for reasons of economy, as the implication is that the hearer is able to provide a reasonable interpretation of the first conjunct. Examples such as given in (13) are typically used to express that the speaker has a specific attitude towards the truth of the proposition expressed by the second conjunct: (13a) expresses that the speaker is uncertain about the truth value of this proposition, (13b) that he has reasons to believe that it is true, and (13c) that he has reasons to conclude that it is true. The question intonation of these sentences conveys that the speaker requests further information about the actual truth value of the proposition.

- (13) a. En heb je het boek gekocht?  
and have you the book bought  
'And did you buy the book?'
- b. Maar jij komt toch ook?  
but you come PRT too  
'But you're coming too, aren't you?'
- c. Dus Peter is boos vertrokken?  
so Peter is angry left  
'So, Peter has left angry?'

Foolen & Van der Wouden (2011) claim that coordinating conjunctions are only used in the coda of an utterance if they are followed by a hesitation marker. In many cases, we can see the use of this marker as an invitation by the speaker to the addressee to complete the missing part.

- (14) a. Peter is erg knap, maar uh.  
Peter is very handsome but er
- b. Mijn ouders zijn weg, dus uh.  
my parents are out so er

The hearer may use conjunctions in order to ask for more information (A: *Peter is ziek* 'Peter is ill' B: *En?* 'And what does that mean for us?'), further explication (A: *Ik heb geen tijd* 'I've got no time' B: *Dus?* 'So what now?'), or to express that he has the feeling that some assertion has a negative implication (A: *Jan is erg knap* 'Jan is very handsome'. B: *Maar?* 'But is there some downside perhaps?').

### B. Discourse markers

While text-connective markers can be considered to be syntactically incorporated, namely in a coordinate structure, this does not hold for discourse markers, which are often prosodically separated from the following sentence by a distinct intonation break. The markers *echter* 'however' and *immers* 'after all' in (15) sound somewhat formal and bookish; the former implies a contrast while the latter introduces a sentence that provides a motivation for an earlier utterance; these markers are given here in utterance-initial position but they can also occur in final position. Note that these elements may also occur in clause-internal position, but in such cases they can be analyzed as clause adverbials; cf. Section 8.2.2.

- (15) a. Ik wil wel komen. Echter, ik weet niet of ik kan.  
I want PRT come However I know not whether I can  
'I do want to come. However, I don't know whether I can.'
- b. Jan helpt je wel. Immers, hij is thuis.  
Jan helps you PRT after all he is home  
'Jan will help you. He is at home, after all.'

The initial markers *trouwens* 'by the way/incidentally' and *overigens* 'for that matter' are quite common in colloquial speech: they indicate that the proposition in the accompanying sentence involves a side issue. In (16), the marker *trouwens* is given the utterance-initial position but it can also be used in medial and final position.

- (16) Peter komt niet. Trouwens, dat is niet de eerste keer.  
 Peter comes not by.the.way that is not the first time  
 ‘Peter won’t come. That’s not the first time, by the way.’

Discourse markers like *ik bedoel* ‘I mean’, *kortom* ‘in short’ and *eerlijk gezegd* ‘frankly’ indicate that the sentence following it is of a special nature: the sentence intends to clarify or to summarize the earlier discourse, or is of a confidential nature.

- (17) Kortom: Ik doe het niet.  
 in.short I do it not  
 ‘In short, I won’t do it.’

Interjections like *tja* and *aha* may express a certain opinion of a preceding utterance or some state of affairs occurring at speech time: *tja* indicates that it is an unexpected or unwanted but open-and-shut case, while *aha* indicates that it is illuminating in one way or another.

- (18) a. Marie is niet hier. Tja, dan ga ik maar naar huis  
 Marie is not here well then go I PRT to home  
 ‘Marie isn’t here. Well, then I’d better go home.’  
 b. Marie is niet hier. Aha, dan zit ze bij Peter.  
 Marie is not here Ah then sits she with Peter  
 ‘Marie isn’t here. Ah, then she’ll be at Peter’s place.’

Discourse markers having the word order of an interrogative clause such as *Weet je* ‘you know’ or an imperative such as *Luister eens!* ‘Listen!’ are often used to introduce a new discourse topic.

- (19) a. Weet je: Ik moet straks weg en ...  
 know you I must later away and  
 ‘You know, I have to leave soon and ...’  
 b. Luister eens: Peter komt straks en ...  
 listen PRT Peter comes later  
 ‘Listen, Peter will come soon and ...’

Discourse markers at the end of the utterance often have a special status in that they facilitate turn-taking. Discourse markers like *toch* or *niet (waar)* elicitate a reply from the hearer and thus invite him to take the next turn: *Peter is al vertrokken, toch/niet(waar)?* ‘Peter has already left, hasn’t he?’ The next subsection will discuss discourse markers that may show up in the new turn.

### III. Responding

The polar elements *ja* ‘yes’ and *nee* ‘no’ are prototypically used as answers to *yes/no*-questions. This is illustrated in the (a)-examples in (20): the polar elements indicate whether or not the open proposition expressed by the question is applicable to the domain of discourse. Such polar phrases can, however, also be used to affirm or to contradict propositions given earlier in the discourse: the (b)-examples provide an instance in which affirmation/contradiction is consciously elicited by the first speaker by virtue of the discourse marker *toch*. The polar phrases *ja/nee* in (20) can be used as independent utterances but they can also be followed by a clause expressing the propositional content of the reply in full.

- (20) a. Is Peter al vertrokken? b. Peter is al vertrokken, toch?  
 Is Peter already left Peter is already left PRT  
 'Has Peter left already?' 'Peter has already left, hasn't he?'  
 a'. Ja, hij is al vertrokken. b'. Ja, hij is al vertrokken.  
 yes he is already left yes he is already left  
 a''. Nee, hij is nog niet vertrokken. b''. Nee, hij is nog niet vertrokken.  
 no he is yet not left no he is yet not left

It is not easy to determine the precise meaning contribution of *ja* and *nee* in examples like those in (20). It seems too simple to say that *ja* expresses confirmation and *nee* expresses denial of some presupposition held by the speaker. This is clear from the fact that the negative counterparts of the examples in (20a&b), which suggest the opposite presuppositions, may trigger exactly the same answers. We ignore the fact that *jawel* may be preferred to *ja* in (21b'); we return to this in our discussion of (26).

- (21) a. Is Peter nog niet vertrokken? b. Peter is nog niet vertrokken, toch?  
 Is Peter yet not left Peter is yet not left PRT  
 'Hasn't Peter left yet?' 'Peter hasn't already left, has he?'  
 a'. Ja, hij is al vertrokken. b'. Ja(wel), hij is al vertrokken.  
 yes he is already left yes he is already left  
 a''. Nee, hij is nog niet vertrokken. b''. Nee, hij is nog niet vertrokken.  
 no he is yet not left no he is yet not left

The fact that the sentences in the primed examples above can be omitted without a clear change of meaning suggests that *ja* and *nee* are in a sense shorthand for, respectively, the positive and the negative sentences following them. One way of formally accounting for this is by saying that these sentences are syntactically present but elided if these polar elements are used independently; See Van Craenenbroeck (2010:ch.15) for related discussion. There are other reasons for assuming this. First, the examples in (22) show that polar *ja* and *nee* can easily be coordinated with full sentences; this would immediately follow if the polar elements are followed by phonetically empty sentences.

- (22) a. Is Peter al vertrokken?  
 Is Peter already left  
 'Has Peter left already?'  
 b. Ja, maar hij komt zo terug.  
 yes but he comes soon back  
 'Yes, but he'll be back soon.'  
 b'. Nee, maar hij heeft wel zijn jas al aan.  
 no but he has prt his coat already on  
 'No, but he's put his coat on already.'

Secondly, polar *ja* and *nee* can also be combined with a non-main clause, as shown by the answers to the question in (23a); this again follows if they are followed by phonetically empty sentences.

- (23) a. Ben je morgen hier?  
 are you tomorrow here  
 'Will you be here tomorrow?'  
 b. Ja, omdat ik mijn werk wil afmaken.  
 yes because I my work want prt.-finish  
 'Yes, because I want to finish my work.'  
 b'. Nee, tenzij je dat wil.  
 no unless you that want  
 'No, unless you want me to.'

Thirdly, if we are indeed dealing with ellipsis, we would expect it to be subject to the °recoverability condition on deletion: elements that cannot be recovered from the context must be overtly expressed. The examples in (24) suggest that this is indeed the case; see Pope (1971) for a larger sample of English examples. Note in passing that there is little or no reason for assuming that *waarschijnlijk morgen* and *natuurlijk niet* are constituents, which gives the ellipsis analysis even greater credibility.

- (24) a. Ben je deze week hier?  
 are you this week here  
 'Will you be here this week?'  
 b. Ja, waarschijnlijk ~~ben ik~~ morgen hier.  
 yes probably am I tomorrow here  
 'Yes, probably tomorrow.'  
 b'. Nee, natuurlijk ~~ben ik deze week hier~~ niet: het is Kerstmis.  
 no of.course am I this week here not it is Christmas  
 'No, of course not: it's Christmas.'

Note that the overtly expressed remnant need not be a clausal constituent. The second sentence in (25a) shows that it can also be a complementizer: as is shown by the near paraphrase in (25b), polar *ja* corresponds to the italicized part of the conditional clause introduced by the complementizer *indien* 'if'.

- (25) a. Ben je geïnteresseerd? Indien ja, stuur dan het formulier in.  
 are you interested if so send then the form in  
 'Are you interested? If so, please return the form.'  
 b. Indien *je geïnteresseerd bent*, stuur dan het formulier in.  
 if you interested are send then the form in  
 'If you are interested, please return the form.'

Finally, the hypothesis of ellipsis may also account for the fact that the preferred answer to the negative question in (26a') is *jawel*: denying a negative proposition generally favors the presence of the affirmative marker *wel*. As contradicting a negative presupposition also favors the presence of *wel*, ellipsis would also account for the use of *jawel* in (26b').

- (26) a. Ben je deze week niet hier? b. Je bent deze week niet hier, toch?  
 are you this week not here you are this week not here PRT  
 'Won't you be here this week?' 'You won't be here this week, will you?'



- b. Ja, ~~ik ben~~ ~~deze week~~ wel hier. b'. Ja, ~~ik~~ ~~ben~~ ~~deze week~~ wel hier.  
 yes I am this week AFF here yes I am this week AFF here  
 'Yes, I will be here this week.' 'Yes, I will be here this week.'

This discussion has shown that polar *ja* and *nee* are not primarily used to affirm or to deny a presupposition, but “agree” with a (possibly elided) positive or negative clause following it. This makes it understandable that these elements can also be used in contexts like (27), in which the hearer simply accepts the truth of the (negative/positive) propositions in the primeless examples.

- (27) a. Jan komt morgen. b. Jan komt morgen niet.  
 Jan comes tomorrow Jan comes tomorrow not  
 'Jan will come tomorrow.' 'Jan won't come tomorrow.'  
 a'. Ja, dat wist ik al. b'. Ja, dat wist ik al.  
 yes that knew I already yes that knew I already  
 'Yes, I knew that already.' 'Yes, I knew that already.'  
 a''. Nee, dat wist ik niet. b''. Nee, dat wist ik niet.  
 no that knew I not no that knew I not  
 'No, I didn't know that.' 'No, I didn't know that.'

Our brief (and incomplete) discussion of the use of the polar elements *ja* ‘yes’ and *nee* ‘no’ shows that they have the hallmark of pragmatic markers in that they do not carry truth-conditional content: they simply indicate that the (possible phonetically empty) clauses they are associated with are positive or negative. In this respect they differ from the polar elements *welles* and *nietes* in (28), which are typically used to contradict or refute a proposition in the immediate preceding discourse.

- (28) a. Ik kom morgen niet. Welles, want het is veel te leuk.'  
 I come tomorrow not Yes because it is much too nice  
 'I won't come tomorrow. Yes, you will, because it will be very nice.'  
 b. Ik kom morgen. Nietes, (want) je moet naar de dokter.  
 I come tomorrow No because you must to the doctor  
 'I'll come tomorrow. No, you won't, because you have to see the doctor.'

Like polar *ja* and *nee*, *welles* and *nietes* seem to have the status of a full clause: this is clear from the fact illustrated in the mini-dialogue in (28) that they can be in a coordinate structure with another clause. It is, however, not clear whether these elements are associated with an elided clause as this clause cannot be made explicit. Furthermore the examples in (29) show that it is not possible to combine these elements with embedded clauses. Note in passing that *welles* and *nietes* also differ in this respect from the affirmative marker *wel* and the negative adverb *niet* ‘not’ in the two mini-dialogues in (29); this is not surprising as we are probably dealing with reduced clauses in that case: ~~Hij komt~~ *wel/niet* ‘you will/won’t’.

- (29) a. Ik kom morgen niet. Wel/\*Welles als Marie het vraagt.'  
 I come tomorrow not AFF/yes if Marie it requests  
 Intended reading: 'I won't come tomorrow. You will when Marie requests it.'  
 b. Ik kom morgen. Niet/\*Nietes als het regent.  
 I come tomorrow no/No if it rains  
 Intended reading: 'I will come tomorrow. You won't when it rains.'

The discussion above has shown that the polar elements *ja* and *nee* are pragmatic markers: they do not have truth-conditional content. We also noted that this is less clear in the case of the polar elements *welles* and *nietes*.

#### IV. Expressing emotional involvement

Discourse particle are sometimes claimed to express the speaker's emotional attitude towards some discourse aspect. Curses, for example, can be used to indicate what the speaker's feelings are toward a specific state of affairs (*Verdomme, wat een regen!* 'Damn! It's pouring!') or a specific behavior of the addressee (*Jezus, man, dat pik ik niet van je!* 'Jesus, man, I won't take that from you'). Many pragmatic markers have an additional emotional value. In answering a question such as *Kom je morgen?* in (30a), modal adverbs like *natuurlijk* 'of course' and *vanzelfsprekend* 'obviously' also have a certain emotional load in addition to expressing mere confirmation. However, it should be noted that the same emotional load is present in sentences such as *Natuurlijk kom ik morgen* 'Of course I will come tomorrow', which can also be used as answers to this question. If the discourse particle *natuurlijk* is actually a reduced clause, its emotional load need not surprise us. A similar analysis may be given for speaker-oriented adverbs such as *helaas* in (30b).

- (30) a. *Kom je morgen? Natuurlijk kom ik morgen!*  
 come you tomorrow of.course come I tomorrow  
 'Are you coming tomorrow! Of course!'
- b. *Ben je hier morgen? Helaas ben ik hier morgen niet/wel.*  
 are you here tomorrow regrettably am I here tomorrow not/AFF  
 'Will you be here tomorrow. Regrettably, no/yes.'

#### V. Conclusion

This section has discussed the use of a set of sentence-external pragmatic markers, which have received a lot of attention since Schiffrin (1987) in, especially, the pragmatic literature. These markers are characterized by the fact that they often do not have clear truth-conditional content but instead perform a wide range of pragmatic functions; they are indexical in that they point to some aspect of the discourse: discourse participants, state of affairs holding at speech time, earlier statements, etc. Discourse markers may have various shapes: they can simply be sounds like *mmm*, *mhm* and *ooo*, lexical elements such as the interjection *hé*, phrasal expressions like *mijn god* 'my god', or (reduced) conventional stock clauses like *Ik bedoel* 'I mean'. Furthermore, we have seen that certain pragmatic markers like the polar element *ja* and *nee* may be inherently associated with a (potentially elided) sentence. Other pragmatic markers may be part of partially elided clauses, e.g., ~~*Dat is*~~ *goed: ik kom morgen* 'O.K., I'll come tomorrow'. The examples above show that many pragmatic markers have arisen as a result of grammaticalization; this also seems to hold for a set of markers that can also be used as adverbial phrases such as *helaas* 'unfortunately'. As a result of this, we find cases like *dus* 'so' and *toch* 'all the same' with a less clear status; see, e.g., Aijmer (2002) and Diewald (2009) on grammaticalization, and Evers-Vermeul (2005/2010) and Degand (2011) for specific case studies of Dutch. As pragmatic markers are characteristic of

discourse and thus not part of syntax in the restricted sense defined in Section 4 of the preface, we will not digress any further here.

## 14.2. Left dislocation

This section discusses left dislocation (henceforth LD). In Dutch, two different types of left-dislocation constructions can be distinguished, which are illustrated in example (31). The first type, which is often referred to as hanging-topic LD, can also be found in English but the second type is characteristic of Dutch and German; it is often referred to as contrastive LD because the left-dislocated phrase is typically assigned contrastive accent (indicated by small caps); some (but not all) speakers also allow this construction without contrastive accent.

- (31) a. Jan, ik heb hem niet gezien. [hanging-topic LD]  
 Jan I have him not seen  
 ‘Jan, I haven’t seen him.’  
 b. JAN, die heb ik niet gezien. [contrastive LD]  
 Jan DEM have I not seen  
 ‘Jan, I haven’t seen him.’

We refer to Van Riemsdijk (1997) and Alexiadou (2006) for introductions to the various forms of LD which are found cross-linguistically; we will confine our discussion here to the two types in (31), which we will refer to by means of the names used by Van Riemsdijk (and which are used in a slightly different way by Alexiadou).

The discussion of LD is organized as follows. Subsection I starts with a general introduction to LD and argues that left-dislocated elements, such as the noun phrase *Jan* in (31), are external to the main clause and are only interpreted as a constituent of the sentence by virtue of being the antecedent of a “resumptive” element in the sentence, such as the referential pronoun *hem* ‘him’ and the demonstrative pronoun *die* ‘that’. Subsections II and III discuss in more detail properties of, respectively, left-dislocated and resumptive elements. Subsections IV through VI focus more specifically on the derivation of contrastive LD-constructions and provide a number of arguments in favor of assuming that sentence-initial resumptive elements such as the pronoun *die* in (31b) are *wh*-moved from some clause-internal position. Subsection VII discusses the old but still unsettled question as to whether topicalization should be analyzed as a special case of LD. Subsection VIII concludes with a brief review of number of theoretical approaches aiming to account for the differences between hanging-topic and contrastive LD. This section will not discuss cases of left-dislocated clauses; the reader is referred to Section 10.3 for relevant discussion.

### I. General properties

LD-constructions are characterized by the fact that left-dislocated phrases are associated with a resumptive element. If we restrict ourselves for the moment to cases such as (32) with a left-dislocated noun phrase, we observe that the resumptive element preferably takes the form of a referential personal pronoun such as *hem* ‘him’ if it is in clause-internal position, but that it takes the form of a distal demonstrative personal pronoun such as *die* ‘that’ if it is in clause-initial position.

The main verbs in these constructions cannot semantically license both the left-dislocated and the resumptive element by assigning them a  $^{\circ}$ thematic role. Since the resumptive pronoun is clearly the recipient of the available thematic role, it is traditionally assumed that the left-dislocated constituent does not occupy a clause-internal position but is instead base-generated in clause-external position, as indicated by the structures in (32); the left-dislocated constituent should then be semantically licensed by functioning as the antecedent of the resumptive element (indicated here by co-indexing).

- (32) a. Jan<sub>i</sub>, [<sub>clause</sub> ik heb hem<sub>i</sub> nog niet gezien]. [hanging-topic LD]  
 Jan I have him yet not seen  
 ‘Jan, I haven’t seen him yet.’
- b. JAN<sub>i</sub>, [<sub>clause</sub> die<sub>i</sub> heb ik nog niet gezien]. [contrastive LD]  
 Jan DEM have I yet not seen  
 ‘Jan, I haven’t seen him yet.’

That the left-dislocated element must be licensed by functioning as the antecedent of a resumptive element can be demonstrated by the unacceptability of examples such as (33), in which no suitable resumptive pronoun is available. We refer the reader to Van Riemsdijk & Zwarts (1997:26) for discussion; there are a number of errors in the published version of this paper (like missing asterisks), which we have tacitly corrected in the discussion below.

- (33) \*Jan<sub>i</sub>, [<sub>clause</sub> ik heb haar<sub>j</sub> nog niet gezien].  
 Jan I have her yet not seen  
 ‘Jan, I haven’t seen her yet.’

There are various empirical arguments in favor of the hypothesis that left-dislocated constituents are clause-external. First and foremost, it explains why the two types of LD-constructions in (31) are special in allowing the finite verb to be preceded by two constituents: as left-dislocated elements are clause-external they do not count for the  $^{\circ}$ verb-second restriction; the representations in (32) are therefore in perfect accord with this restriction. Second, the hypothesis is supported by the fact that polar elements *ja* ‘yes’ and *nee* ‘no’ can follow the left-dislocated constituent; under the standard assumption discussed in Section 14.1, sub III, that *ja* and *nee* cannot occur clause-internally, the left-dislocated phrases in (34) must be clause-external as well. We will return to cases like these in Subsection VII.

- (34) a. Jan<sub>i</sub>, nee, ik heb hem<sub>i</sub> niet gezien. [hanging-topic LD]  
 Jan no I have him not seen  
 ‘Jan, no, I haven’t seen him.’
- b. JAN<sub>i</sub>, nee, die<sub>i</sub> heb ik niet gezien. [contrastive LD]  
 Jan no DEM have I not seen  
 ‘Jan, no, I haven’t seen him.’

Third, the hypothesis that left-dislocated constituents are clause-external provides a simple account for the fact that LD is a typical root phenomenon, that is, cannot apply in embedded contexts: complement clauses cannot be preceded by a left-

dislocated constituent. For completeness' sake, observe that the (b)-examples are unacceptable both with and without the complementizer *dat* 'that'.

- (35) a. Ik geloof [dat zij Jan/hem nog niet gezien heeft].  
 I believe that she Jan/him yet not seen has  
 'I believe that she hasn't seen Jan/him yet.'
- b. \*Ik geloof [Jan<sub>i</sub> [(dat) zij hem<sub>i</sub> nog niet gezien heeft]]. [hanging-topic LD]  
 I believe Jan that she him yet not seen has
- b'. \*Ik geloof [JAN<sub>i</sub> [die<sub>i</sub> (dat) zij t<sub>i</sub> nog niet gezien heeft]]. [contrastive LD]  
 I believe Jan DEM that she yet not seen has

Salverda (2000:102) claims that embedded contrastive left-dislocation is acceptable in spoken Dutch if the left-dislocated element and the resumptive pronoun are placed after the complementizer *dat* 'that', as in (36b), but we agree with Van Riemsdijk & Zwarts (1997:13) that this pattern is not acceptable in the standard language; the same holds for the corresponding hanging-topic construction in (36a). The use of the asterisks in (36) is not meant to express that the patterns in (36) cannot be found in certain varieties of spoken Dutch. In fact, we expect them to be possible in the regional variety of Dutch spoken in Friesland, because Frisian *does* allow (some sort of) embedded contrastive LD; we refer the reader to De Haan (2010: Section 5.3) for examples and discussion.

- (36) a. \*Ik geloof [dat Jan<sub>i</sub>, zij heeft hem<sub>i</sub> niet gezien]. [hanging-topic LD]  
 I believe that Jan she has him not seen
- b. \*Ik geloof [dat JAN<sub>i</sub>, die<sub>i</sub> heeft zij niet gezien]. [contrastive LD]  
 I believe that Jan DEM has she not seen

Example (35a) can be the input for LD if the left-dislocated element is situated to the left of the complete sentence, as shown by the examples in (37). That *Jan* can be construed as the object of the embedded clause in (37a) is not surprising given that it is normal for the resumptive referential pronoun *hem* to take a non-local antecedent, that is, an antecedent that is not part of its own clause. That it can be construed as the object of the embedded clause in (37b) as well can be accounted for by assuming that the resumptive demonstrative pronoun is extracted from the embedded clause by means of *wh*-movement, which we have indicated by means of the trace *t<sub>i</sub>*. Evidence that *wh*-movement is involved in contrastive (but not hanging topic) LD will be given in Subsection IV.

- (37) a. Jan<sub>i</sub>, [Ik geloof [dat zij hem<sub>i</sub> nog niet gezien heeft]]. [hanging-topic LD]  
 Jan I believe that she him yet not seen has  
 'Jan, I believe she hasn't seen him yet.'
- b. JAN<sub>i</sub>, [die<sub>i</sub> geloof ik [dat zij t<sub>i</sub> nog niet gezien heeft]]. [contrastive LD]  
 Jan DEM believe I that she yet not seen has  
 'Jan, I believe she hasn't seen him yet.'

Hanging-topic and contrastive LD do not allow stacking in Dutch; note that changing the order of the left-dislocated phrases in (38) will not affect the acceptability judgments. It is not clear how to account for this fact given that some

of the types of LD found in other languages do allow stacking; see Alexiadou (2006) for discussion.

- (38) a. \*Jan<sub>i</sub>, dit boek<sub>j</sub> [<sub>clause</sub> ik heb het<sub>j</sub> hem<sub>i</sub> gegeven]. [2 x hanging-topic LD]  
 Jan this book I have it him given  
 b. \*JAN<sub>i</sub>, DIT BOEK<sub>j</sub> [<sub>clause</sub> die<sub>i</sub> heeft dat<sub>j</sub> niet gelezen]. [2x contrastive LD]  
 Jan this book DEM have DEM not read

Combining hanging-topic LD and contrastive LD, on the other hand, is possible; see Zaenen (1997). Observe that the hanging topic in the examples in (39) must precede the contrastively left-dislocated phrase. Inversion of the order of the left-dislocated phrases in (39) gives rise to a severely degraded result. This means that hanging topics can never separate a contrastively dislocated phrase from its *wh*-moved demonstrative correlate in sentence-initial position, despite the fact illustrated in (34b) that other clause-external material can intervene between these elements.

- (39) a. Jan<sub>i</sub>, DIT BOEK<sub>j</sub>, [<sub>clause</sub> dat<sub>j</sub> heeft hij<sub>i</sub> niet gelezen]. [HT + contr. LD]  
 Jan this book DEM has he not read  
 b. \*Dit boek<sub>j</sub>, JAN<sub>i</sub>, [<sub>clause</sub> die<sub>i</sub> heeft het<sub>j</sub> niet gelezen]. [HT + contr. LD]  
 this book Jan DEM has it not read

Finally, observe that examples such as (40) are acceptable. Given the generalization that hanging topics precede contrastively left-dislocated phrases, example (40a) might perhaps be analyzed in the same way as (39a), with two independently left-dislocated phrases, a hanging topic followed by a contrastively left-dislocated phrase. A similar analysis is, however, less likely for example (40b), because (38b) has shown that stacking of contrastively dislocated phrases is excluded.

- (40) a. Jan<sub>i</sub>, [dat zij hem<sub>i</sub> nog niet gezien heeft]<sub>j</sub>, dat<sub>j</sub> geloof ik niet *t<sub>j</sub>*.  
 Jan that she him yet not seen has that believe I not  
 ‘Jan, I don’t believe that she hasn’t seen him yet.’  
 b. JAN<sub>i</sub>, [dat zij DIE<sub>i</sub> nog niet gezien heeft]<sub>j</sub>, dat<sub>j</sub> geloof ik niet *t<sub>j</sub>*.  
 Jan that she DEM yet not seen has that believe I not  
 ‘Jan, I don’t believe that she hasn’t seen him yet.’

This seems to leave us no other option than to adopt the analysis of (40b) in Haeseryn et al. (1997:1390), according to which *Jan* is left-dislocated to the object clause, as in the structure indicated in (41b). If correct, it is natural to assume a similar analysis for (40a), that is, with the hanging-topic left-dislocated to the object clause, as indicated in (41a). This is quite surprising in light of our earlier conclusion drawn on the basis of the (b)-examples in (35) that complement clauses cannot be preceded by a left-dislocated constituent: we have to conclude that this is possible after all, but *only* if they are left-dislocated themselves.

- (41) a. [Jan<sub>i</sub>, [dat zij hem<sub>i</sub> nog niet gezien heeft]<sub>j</sub>], dat<sub>j</sub> geloof ik niet *t<sub>j</sub>*.  
 b. [JAN<sub>i</sub>, [dat zij die<sub>i</sub> nog niet gezien heeft]<sub>j</sub>], dat<sub>j</sub> geloof ik niet *t<sub>j</sub>*.

A similar analysis is plausible for the examples in (42), with a left-dislocated conditional clause. More examples of this type can be found in Paardekooper (1986:417).

- (42) a. [Jan<sub>i</sub>, [als hij<sub>j</sub> blijft zeuren]]<sub>j</sub>, dan<sub>j</sub> ga ik weg.  
 Jan if he remains nagging then go I away  
 ‘Jan, if he remains nagging, I will leave.’
- b. [JAN<sub>i</sub>, [als die<sub>i</sub> blijft zeuren]]<sub>j</sub>, dan<sub>j</sub> ga ik weg.  
 Jan if DEM remains nagging then go I away  
 ‘Jan, if he remains nagging, I will leave.’

Note that the resumptive demonstrative *die* is not in the initial position of the object clause in (41b)/(42b); this is not unexpected as Subsection IV will show that the demonstrative can remain *in situ* if topicalization is excluded for independent reasons.

Semantically, the two types of left-dislocation constructions can be characterized by saying that the sentence is “about” the left-dislocated complement but they differ in that hanging-topic constructions are normally not contrastive. This can be illustrated in the coordination of LD-constructions by the conjunction *maar* ‘but’, which imposes an opposition between the two conjuncts: example (43a) is acceptable only if the resumptive object pronoun *hem* ‘him’ is assigned contrastive accent, while the resumptive demonstrative *die* in (43b) does not need any special marking (although it should be noted that it is accented in any case).

- (43) a. Jan, ik heb HEM/\*’m niet gezien, maar Marie wel. [hanging-topic LD]  
 Jan, I have him/him not seen but Marie AFF  
 ‘Jan, I haven’t seen him but I did see Marie.’
- b. JAN<sub>i</sub>, die<sub>i</sub> heb ik niet gezien, maar Marie wel. [contrastive LD]  
 Jan DEM have I not seen but Marie AFF  
 ‘Jan, I haven’t seen him but I did see Marie.’

## II. The left-dislocated element

The previous subsection has already shown that noun phrases may occur both in hanging-topic and contrastive LD-constructions. The examples in (44) show that such left-dislocated nominal phrases can be associated with a resumptive pronoun with the function of subject, (in)direct object, and the nominal part of a PP-object. It may be the case that some speakers prefer the contrastive left-dislocation construction in the case of a subject, but both constructions seem fully acceptable.

- (44) a. Jan<sub>i</sub>, [<sub>clause</sub> hij<sub>j</sub> is niet aanwezig]. [subject; hanging-topic LD]  
 Jan he is not present
- a’. JAN<sub>i</sub>, [<sub>clause</sub> die<sub>i</sub> is niet aanwezig]. [subject; contrastive LD]  
 Jan DEM is not present  
 ‘Jan, he isn’t present.’
- b. Dit boek<sub>i</sub>, [<sub>clause</sub> ik geef het<sub>i</sub> aan Peter]. [DO; hanging-topic LD]  
 this book I give it to Peter
- b’. DIT BOEK<sub>i</sub>, [<sub>clause</sub> dat<sub>i</sub> geef ik aan Peter]. [DO; contrastive LD]  
 this book DEM give I to Peter  
 ‘This book, I’ll give it to Peter.’
- c. Peter<sub>i</sub>, [<sub>clause</sub> ik geef hem<sub>i</sub> dit boek]. [IO; hanging-topic LD]  
 Peter I give him this book
- c’. PETER<sub>i</sub>, [<sub>clause</sub> die<sub>i</sub> geef ik dit boek]. [IO; contrastive LD]  
 Peter DEM give I this book  
 ‘Peter, I’ll give him this book.’



- d. Jan<sub>i</sub>, ik wacht niet langer [<sub>PP</sub> op hem<sub>i</sub>]. [PO; hanging-topic LD]  
 Jan, I wait no longer for him
- d'. JAN<sub>i</sub>, daar<sub>i</sub> wacht ik niet langer [<sub>PP</sub> t<sub>i</sub> op]. [PO; contrastive LD]  
 Jan, there wait I not longer for  
 'Jan, I won't wait for him any longer.'

Left-dislocated nominal phrases can also be associated with resumptive pronouns originating in a more deeply embedded position. This is illustrated in (45) for respectively, a nominal complement and the nominal part of PP-complement of a °complementive AP. We refer the reader to Subsection V for a discussion of cases in which the resumptive pronouns originates in an embedded clause.

- (45) a. Jan<sub>i</sub>, ik ben [<sub>AP</sub> hem<sub>i</sub> beu]. [hanging-topic LD]  
 Jan I am him fed.up
- a'. JAN<sub>i</sub>, die ben ik [<sub>AP</sub> t<sub>i</sub> beu]. [contrastive LD]  
 Jan DEM am I fed.up  
 'Jan, I am fed up with him'
- b. Dat gezeur<sub>i</sub>, ik word er<sub>i</sub> [<sub>AP</sub> moe [<sub>PP</sub> t<sub>i</sub> van]]. [hanging-topic LD]  
 that nagging I become there tired of
- b'. DAT GEZEUR<sub>i</sub>, daar word ik [<sub>AP</sub> moe [<sub>PP</sub> t<sub>i</sub> van]]. [contrastive LD]  
 that nagging that become I tired if  
 'That nagging, I am getting tired of it.'

The primed examples in (46) show that in contrastive LD-constructions the left-dislocated element can also be an AP, a PP or a verbal projection. Zaenen (1997) claims that hanging-topic LD-constructions give rise to degraded results in these cases but there appears to be speaker variation in this respect, which we indicated by means of the percentage sign.

- (46) a. % [Erg slim]<sub>i</sub>, hij is het<sub>i</sub> niet. [AP (complementive)]  
 very smart he is it not
- a'. [ERG SLIM]<sub>i</sub>, dat<sub>i</sub> is hij niet t<sub>i</sub>.  
 very smart DEM is he not  
 'Very smart, he is not.'
- b. % [In Amsterdam]<sub>i</sub>, ik heb er<sub>i</sub> gewerkt. [PP (adverbial)]  
 in Amsterdam I have there worked
- b'. [IN AMSTERDAM]<sub>i</sub>, daar<sub>i</sub> heb ik t<sub>i</sub> gewerkt.  
 in Amsterdam there have I worked  
 'In Amsterdam, I have worked there.'
- c. % [Boeken gekocht]<sub>i</sub>, ik heb het<sub>i</sub> niet. [VP (lexical projection main verb)]  
 books bought I have that not
- c'. [BOEKEN GEKOCHT]<sub>i</sub>, dat<sub>i</sub> heb ik niet t<sub>i</sub>.  
 books bought that have I not  
 'I haven't bought books.'

The examples in (44) and (46) also show that left-dislocated phrases can be antecedents of resumptive elements having different syntactic functions in the case of contrastive left-dislocation: the examples in the previous subsection have shown that they can be antecedents of resumptive demonstratives that function as

arguments, and the examples above show that the resumptive may also be a complementive (46a), an adverbial phrase (46b), and can even replace part of the lexical projection of the main verb (46c). The markedness of the primeless examples in (46) suggests that the left-dislocated phrases in hanging-topic LD-construction are normally antecedents of pronominal arguments.

Saying that left-dislocated phrases can be nominal is not very precise given that there are various additional restrictions on left dislocation of noun phrases. Furthermore, hanging-topic and contrastive constructions seem to differ in that the left-dislocated element must be definite in the former but not in the latter.

- (47) a. Het/\*Een boek van Reve, ik heb het gelezen. [hanging-topic LD]  
 the/a book by Reve I have it read  
 ‘The/a book by Reve, I have read it.’  
 b. HET/<sup>0%</sup>EEN BOEK VAN REVE, dat heb ik gelezen. [contrastive LD]  
 the/a book by Reve DEM have I read  
 ‘The/a book by Reve, I have read that.’

The use of the percentage sign in (47b) is motivated by the fact that Zaenen (1997) gives a similar example as marked. It seems to us that judgments may differ from case to case, perhaps depending on to whether or not the indefinite noun phrase allows a specific interpretation, that is, depending on whether the speaker is able to identify the referent of the noun phrase. This would in fact be in keeping with Zaenen’s (1997:142) specificity requirement, according to which contrastive LD “can only be used felicitously when the speaker has a “recoverable” referent in mind for the initial constituent”. In accordance with this, left-dislocated noun phrases are often introduced by a D-linked demonstrative like *dit/dat* ‘this/that’ and referential possessive noun phrase. As expected, there does not seem to be any contrast between hanging-topic and contrastive LD in such cases.

- (48) a. Dat/Je boek van Reve, ik heb het gelezen. [hanging-topic LD]  
 that/your book by Reve I have it read  
 ‘That/Your book by Reve, I have read it.’  
 b. DAT/JE BOEK VAN REVE, dat heb ik gelezen. [contrastive LD]  
 that/your book by Reve DEM have I read  
 ‘That/Your book by Reve, I have read that.’

The acceptability of left-dislocated °weak quantified noun phrases depends on the quantifier; Zaenen (1997:141) shows that negative articles such as *geen* ‘no’ also block contrastive LD, while determiners like *vele* ‘many’ en *enkele* ‘some’ at least marginally allow contrastive (but not hanging topic) LD.

- (49) a. \*Geen boek van Reve, ik heb het gelezen. [hanging-topic LD]  
 no book by Reve I have it read  
 a’. \*GEEN BOEK VAN REVE, dat heb ik gelezen. [contrastive LD]  
 no book by Reve DEM have I read  
 b. \*Vele/Enkele boeken van Reve, ik heb ze gelezen. [hanging-topic LD]  
 many/some books by Reve I have them read  
 b’. <sup>??</sup>VELE/ENKELE BOEKEN VAN REVE, die heb ik gelezen. [contrastive LD]  
 many/some books by Reve DEM have I read

Zaenen also claims contrastive left-dislocation of strong quantified noun phrases introduced by *alle* 'all', *elk(e)* 'each' and *de meeste* 'most' to be possible, but to our ear such cases seem somewhat marked, which we express in (50) by means of a single question mark; see also Van Riemsdijk & Zwarts (1997:fn.5), who reject examples like (50a'). The hanging-topic constructions all seem more degraded than the corresponding contrastive LD-constructions; cf. Vat (1997). Note that the judgments given here diverge somewhat from those in Vat, which may be related to the fact that Vat somewhat idealizes the data for the sake of simplicity (see Vat's remark on p.71).

- (50) a. <sup>??</sup>Alle boeken van Reve, ik heb ze gelezen. [hanging-topic LD]  
 all books by Reve I have them read  
 a'. <sup>?</sup>ALLE BOEKEN VAN REVE, die heb ik gelezen. [contrastive LD]  
 all books by Reve DEM have I read  
 b. <sup>??</sup>De meeste boeken van Reve, ik heb ze gelezen. [hanging-topic LD]  
 the most books by Reve I have them read  
 b'. <sup>?</sup>DE MEESTE BOEKEN VAN REVE, die heb ik gelezen. [contrastive LD]  
 the most books by Reve DEM have I read  
 c. <sup>??</sup>Elk boek van Reve, ik heb het gelezen. [hanging-topic LD]  
 each book by Reve I have it read  
 c'. <sup>?</sup>ELK BOEK VAN REVE, dat heb ik gelezen. [contrastive LD]  
 each book by Reve DEM have I read

It must be obvious, however, that passing judgments is a somewhat delicate matter because the (a)- and (b)-examples in (50) compete with the even more natural examples in (51). In the (a)-examples quantification is expressed by the floating quantifier *allemaal* 'all' and in the (b)-examples by the determiner of a nominal phrase pied-piped by the resumptive element *er*. We therefore want to stress that (as always) the diacritics on the examples in (47) to (51) express relative and not absolute judgments.

- (51) a. De boeken van Reve, ik heb ze allemaal gelezen. [hanging-topic LD]  
 the books by Reve I have them all read  
 a'. DE BOEKEN VAN REVE, die heb ik allemaal gelezen. [contrastive LD]  
 the books by Reve DEM have I all read  
 b. De boeken van Reve, ik heb de meeste ervan gelezen. [hanging-topic LD]  
 the books by Reve I have the most of.them read  
 b'. DE BOEKEN VAN REVE, de meeste ervan heb ik gelezen. [contrastive LD]  
 the books by Reve the most of.them have I read

The discussion above shows that left dislocation of noun phrases provides the best result if the left-dislocated noun phrase is referential: quantified noun phrases are always marked compared to definite noun phrases introduced by a definite article, or a definite demonstrative/possessive pronoun. This conclusion is further supported by the fact that left dislocation of non-referential noun phrases is not possible; see Van Riemsdijk & Zwarts (1997) and Vat (1997), although the latter provides a number of cases in note 5 that they claim to allow contrastive LD. We illustrate this in (52) by means of the idiomatic expression *ergens de ballen van geloven* with the

non-referential nominal phrase *de ballen*; observe that we have added the asterisk, which was accidentally omitted from the published version.

- (52) a. Ik geloof er de ballen van.  
I believe there the balls of  
'I don't believe a word of it.'
- b. \*De ballen, ik geloof ze er van. [hanging-topic LD]  
the balls I believe them there of
- b'. \*DE BALLEEN, die geloof ik er van. [contrastive LD]  
the balls DEM believe I there of

In other cases, LD results in the loss of the idiomatic interpretation: the number signs in the (b)-examples in (53) indicate that only the literal transmission reading survives in LD-constructions.

- (53) a. Jan geeft de pijp aan Maarten.  
Jan gives the pipe to Maarten  
Idiomatic reading: 'Jan is dying.'
- b. #De pijp, Jan geeft hem aan Maarten. [hanging-topic LD]  
the pipe Jan gives him to Maarten
- b'. #DE PIJP, die geeft Jan aan Maarten. [contrastive LD]  
the pipe, DEM gives Jan to Maarten

The claim that left-dislocated phrases must be referential also accounts for the fact noticed by Zaenen (1997) that *wh*-phrases cannot be left-dislocated. This is illustrated in the examples in (54), which show that interrogative phrases differ sharply in this respect from demonstrative phrases.

- (54) a. \*Wie/Welke man, ik heb hem niet gezien. [hanging-topic LD]  
who/which man I have him not seen
- a'. Die/Deze (man), ik heb hem niet gezien. [hanging-topic LD]  
this/that man I have him not seen
- b. \*WIE/WELKE MAN, die heb ik niet gezien. [contrastive LD]  
who/which man DEM have I not seen
- b'. DIE/DEZE (MAN), die heb ik niet gezien. [contrastive LD]  
this/that man DEM have I not seen

Another case that may show the same is LD of reflexive and reciprocal personal pronouns, as such pronouns are not inherently referential but depend on an antecedent for their reference. Van Riemsdijk & Zwarts (1997) as well as Vat (1997) suggest, however, that the unacceptability of the examples in (55) might also be attributed to problems related to °binding. An updated version of this proposal would attribute it to the fact that the resumptive pronouns *hen* 'them' and *die* must take the subject *zij* 'they' as a local antecedent in order to satisfy the binding conditions on *elkaar* 'each other', which results in a violation of the binding conditions that they must satisfy themselves (i.e., that they must be free in their local domain); note that the binding conditions for the resumptive pronoun *die* in (55b) should be computed from its original object position indicated by a trace. We

refer the reader to Section N5.2.1.5 for a more extensive discussion of the binding conditions.

- (55) a. \*Elkaar<sub>i</sub>, zij<sub>j</sub> respecteren hen<sub>i</sub> niet. [hanging-topic LD]  
 each.other they respect them not  
 b. \*ELKAAR<sub>i</sub>, die<sub>i</sub> respecteren zij<sub>j</sub>-t<sub>i</sub> niet. [contrastive LD]  
 each.other DEM respect they not

The account of the unacceptability of the examples in (55) can be supported for the contrastive LD-construction in (55b) by the fact that example (56b) is fully acceptable, which can be made to follow from the fact that the resumptive pronoun *die* is not bound by the subject *zij* in this case. This leaves us with the question as to why (56a) is still unacceptable. This is related to the “connectedness” hypothesis proposed in Vat (1997), according to which the hanging-topic and the contrastive LD-construction differ in that only the latter allow left-dislocated phrases to be interpreted as if they occupy the position of the resumptive pronoun; this means that the reciprocal *elkaar* ‘each other’ is correctly bound in its local domain in (56b), but not in (56a).

- (56) a. \*[Elkaars<sub>i</sub> jassen]<sub>j</sub>, zij<sub>j</sub> dragen ze<sub>j</sub> niet graag. [hanging-topic LD]  
 each.other’s coats they wear them not happily  
 b. [ELKAARS<sub>i</sub> JASSEN]<sub>j</sub>, die<sub>j</sub> dragen zij<sub>j</sub> t<sub>j</sub> niet graag. [contrastive LD]  
 each.other’s coats DEM wear them not gladly  
 ‘Each other’s coats, they do not like to wear them.’

More evidence for this “connectedness” hypothesis is provided by examples such as (57) in which the indices indicate that pronouns embedded in left-dislocated phrases only allow a °bound-variable reading in contrastive LD-constructions: whereas the hanging topic in (57a) must refer to a certain person’s mother, who is liked by everyone, the contrastively LD-construction in (57b) in addition allows an interpretation according to which everyone likes his own mother; see also Zaenen (1997). For a more extensive discussion of the “connectedness” hypothesis (partly based on evidence from German), we refer to Vat (1997) and Ott (2014).

- (57) a. [Zijn<sub>k</sub>/<sub>\*i</sub> moeder]<sub>j</sub>, iedereen<sub>i</sub> vindt haar<sub>j</sub> aardig. [hanging-topic LD]  
 his mother everyone considers her kind  
 ‘His mother, everyone likes her.’  
 b. [ZIJN<sub>k</sub>/i MOEDER]<sub>j</sub>, die<sub>j</sub> vindt iedereen<sub>i</sub> t<sub>j</sub> aardig. [contrastive LD]  
 his mother DEM considers everyone kind  
 ‘His mother, everyone likes her.’

It has also been claimed that referential pronouns such as *hem* ‘him’ cannot be left-dislocated; cf. Zwart (1997:249). If true, this would be a surprising fact given that there does not appear to be any obvious reason why this should be the case. It seems to us, however, that with sufficient context such cases are quite acceptable (see the answers to question (58a)), but we will leave it to future research to establish more exactly the acceptability status of such examples.

- (58) a. Ik ben op zoek naar Peter maar kan hem niet vinden. Heb jij hem gezien?  
 'I am looking for Peter but I cannot find him. Have you seen him?'  
 b. <sup>%</sup>Hem, nee, ik heb hem niet gezien. [hanging-topic LD]  
 him no I have him not seen  
 'Him, no, I haven't seen him.'  
 b'. <sup>%</sup>HEM, nee, die heb ik niet gezien. [contrastive LD]  
 him no DEM have I not seen  
 'Him, no, I haven't seen him.'

It has further been claimed more specifically that first and second person pronouns cannot be left-dislocated; cf. De Wit (1997). Although such pronouns indeed seem to give rise to a marked result if they are used as hanging topics, we have the impression that they can comfortably be used in contrastive LD-constructions. We therefore mark the primed examples in (59) with a percentage sign, and leave it to future research to determine more precisely their acceptability status.

- (59) a. <sup>\*?</sup>Mij, Peter wil mij niet meer helpen. [hanging-topic LD]  
 me Peter wants me not more help  
 a'. <sup>%</sup>MIJ, die wil Peter niet meer helpen. [contrastive LD]  
 me DEM wants Peter not more help  
 'Peter doesn't want to help me anymore.'  
 b. <sup>\*?</sup>Jou, Peter wil jou niet meer helpen. [hanging-topic LD]  
 you Peter wants you not more help  
 b'. <sup>%</sup>JOU, die wil Peter niet meer helpen. [contrastive LD]  
 you DEM wants Peter not more help  
 'Peter doesn't want to help me anymore.'

For completeness' sake we note here that hanging-topic LD of pronouns improves greatly if the left-dislocated phrase is a coordinate structure, as in (60). This suggests that the presumed markedness of the primeless examples in (59) may be due to the repetition of identical forms.

- (60) a. [Hem en haar], ik heb ze niet gezien.  
 him and her, I have them not seen  
 'Him and her, I haven't seen them.'  
 b. [Zij en jij], jullie zijn altijd welkom.  
 she and you you are always welcome  
 b'. [Jou en haar], ik heb jullie niet gezien.  
 you and her, I have you not seen  
 'You and her, I haven't seen you.'  
 c. [Jij en ik] we vormen een goed team.  
 you and I we constitute a good team  
 c'. [Jou en mij], ze willen ons niet helpen.  
 you and me they want us not help  
 'You and me, they don't want to help us.'

Contrastive dislocation seems to improve if a focus marker like *zelfs* 'even' or *ook* 'also' is present.

- (61) a. HEM, nee, <zelfs> die heb ik niet gezien.  
 him no even DEM have I not seen  
 ‘Him, no, I even haven’t seen him.’
- b. MIJ, die wil Peter OOK niet meer helpen.  
 me DEM wants Peter also not more help  
 ‘Peter doesn’t want to help me anymore either.’

The discussion of the examples in (55) to (61) shows that although LD of pronominal elements may give rise to degraded results, this need not be due to a syntactic restriction on LD: the unacceptability of the examples in (55), for example, may be due to the independently motivated binding conditions, and the judgments on (58) and (59) are not sufficiently clear to draw any firm conclusions and are furthermore affected by various non-syntactic factors that have not been investigated yet. The examples in (61), finally, show that LD of pronominal elements is sometimes fully acceptable.

### *III. The resumptive element*

The resumptive element in hanging-topic constructions is relatively straightforward: because the construction only gives rise to a fully acceptable result if the left-dislocated element is nominal, it is typically a referential personal pronoun. In the previous subsections, we assumed without discussion that resumptive elements in contrastive LD-constructions with a nominal left-dislocated phrase are D-linked distal demonstrative pronouns. One reason for assuming this is that the resumptive pronouns behave like demonstratives in that they agree in gender and number with their antecedent; see Section N5.2.3.1.1, sub I, for a discussion of the paradigm of demonstrative pronouns.

- (62) a. DEZE JONGEN<sub>[-neuter, singular]</sub>, die<sub>[-neuter, singular]</sub> ken ik niet.  
 this boy DEM know I not  
 ‘This boy, I don’t know him.’
- a’. DEZE JONGENS<sub>[-neuter, plural]</sub>, die<sub>[-neuter, plural]</sub> ken ik niet.  
 this boy DEM know I not  
 ‘These boys, I don’t know them.’
- b. DIT BOEK<sub>[+neuter, singular]</sub>, dat<sub>[+neuter, singular]</sub> lees ik niet.  
 this book DEM read I not  
 ‘This book, I won’t read it.’
- b’. DEZE BOEKEN<sub>[+neuter, plural]</sub>, die<sub>[+neuter, plural]</sub> lees ik niet.  
 these books DEM read I not  
 ‘These books, I won’t read them.’

It should be noted, however, that the agreement pattern in (62) would also allow an analysis of the resumptive pronouns as relative pronouns (cf. Section N5.2.1.4), and it has indeed been suggested that this might be a reasonable line of inquiry; see Van Riemsdijk (1997: Section 4). Given that relative pronouns are obligatorily moved into clause initial position, this would lead us to expect that resumptive pronouns are also obligatorily moved into clause-initial position in contrastive LD-constructions. Subsection IV will show, however, that this expectation is not borne out. Another problem for the suggested analysis is that the resumptive pronouns can



be replaced by an epithet like *die idioot* ‘that idiot’ or *dat wijf* ‘that bitch’ in (63); cf. Van Riemsdijk & Zwarts (1997) and Zaenen (1997). Analyzing contrastive LD-constructions such as (63b) as relative constructions does not seem possible. Another problematic case adapted from De Vries (2009) is given in (63c), in which the left-dislocated coordinate structure is resumed by the encompassing phrase *al die dingen* ‘all those things’.

- (63) a. Peter<sub>i</sub>, Ik heb net gesproken met die idioot<sub>i</sub>. [hanging-topic LD]  
 Peter, I have just spoken with that idiot
- b. MARIE<sub>i</sub>, dat wijf<sub>i</sub> vermoord ik  $t_i$  nog eens. [contrastive LD]  
 Marie that bitch kill I yet once  
 ‘Marie, I will kill that bitch one day.’
- c. [Boeken, CDs en schilderijen]<sub>i</sub>, al die dingen<sub>i</sub> boeien me. [contrastive LD]  
 books CDs and paintings all those things attract me  
 ‘Books, CDs and painting, all those things fascinate me.’

A relative clause-like analysis is also unlikely in the light of contrastive LD-constructions such as (64), which are repeated in a slightly different form from Subsection II. Although adjectival complementives and verbal projections can be used as antecedents of (non-restrictive) relative clauses, the relative pronouns would surface as *wat* not as *dat*: cf. *Jan is erg slim, wat/\*dat ik niet ben* ‘Jan is very smart, which I am not’ and *Jan heeft de boodschappen gedaan, wat/\*dat ik vergeten was* ‘Jan has done the shopping, which I had forgotten’. Furthermore, the relative pronoun that may take a phrase denoting a location as its antecedent is *waar* not *daar*; cf. *De stad waar/\*daar hij woont is Amsterdam* ‘the city where he lives is Amsterdam’. The resumptive elements in (64) thus simply do not have the form expected of a relative element. We refer the reader to Section N3.3.2.2 for a discussion of the form of relative pro-forms in Dutch.

- (64) a. [ERG SLIM]<sub>i</sub>, dat<sub>i</sub>/\*wat<sub>i</sub> is hij niet  $t_i$ . [AP (complementive)]  
 very smart that/which is he not  
 ‘Very smart, he is not.’
- b. [IN AMSTERDAM]<sub>i</sub>, daar<sub>i</sub>/\*waar<sub>i</sub> heb ik  $t_i$  gewerkt. [PP (adverbial)]  
 in Amsterdam there/where have I worked  
 ‘In Amsterdam, I have worked there.’
- c. [BOEKEN GEKOCHT]<sub>i</sub>, dat<sub>i</sub>/\*wat<sub>i</sub> heb ik niet  $t_i$ . [lexical projection verb]  
 books bought that/which have I not  
 ‘I haven’t bought books.’

The same holds for contrastive LD-constructions with left-dislocated temporal adverbial phrases: while the resumptive element *toen* ‘then’ in (65a) can indeed occasionally be found in relative clauses (cf. Section N3.3.2.2, sub IVC), this does not hold for the form *dan* ‘then’ in (65a’). Locational pro-forms such as *daar* ‘there’ in constructions such as (65b) cannot be used in relative clauses either and the same holds for the pronominal PP *daarmee* and the adverbial pro-form *zo* in (65c&d).

- (65) a. Gisteren, toen was ik ziek.  
 yesterday then was I ill  
 'Yesterday, I was ill then.'
- a'. Morgen, dan kom ik wat later.  
 tomorrow then come I somewhat later  
 'Tomorrow, I will arrive a bit later.'
- b. In Amsterdam, daar kom ik graag.  
 in Amsterdam there come I gladly  
 'Amsterdam, I like to go there.'
- c. Met zo'n oude computer, daarmee kan je toch niet werken.  
 with such.an old computer with.that can you PRT not work  
 'With such an old computer, it is impossible to work.'
- d. Rustig, zo moet je ademen.  
 quietly so must you breathe  
 'You should breathe quietly.'

The discussion above suggests that it is safe to conclude that the resumptive elements in contrastive LD-constructions are distal demonstrative (and not relative) pro-forms; see Haeseryn et al. (1997:1389) for the same conclusion.

#### IV. *Wh-movement*

The previous subsection has argued that it is reasonable to assume that the verb assigns its thematic role to the resumptive pronoun, and, consequently, that the left-dislocated element cannot be licensed within the clause. It implies that a left-dislocated noun phrase must be base-generated external to the clause and receive a semantic interpretation by acting as the antecedent of the resumptive pronoun. The examples in (66) and (67) show, however, that the two types of resumptive pronouns seem to exhibit a differential behavior with respect to *wh*-movement. Although examples like (66b) are generally not discussed in the literature, our informants indicate that *wh*-movement of the referential personal pronoun gives rise to at least a marked result.

- (66) a. Jan<sub>i</sub> [<sub>clause</sub> ik heb hem<sub>i</sub> nog niet gezien]. [hanging-topic LD]  
 Jan I have him yet not seen  
 'Jan I haven't seen him yet.'
- b. ??JAN<sub>i</sub> [<sub>clause</sub> hem<sub>i</sub> heb ik t<sub>i</sub> nog niet gezien]. [contrastive LD]  
 Jan him have I yet not seen

The reception of examples such as (67a) is a mixed one: Van Riemsdijk (1997) indicates without any reservation that demonstratives are possible in hanging-topic LD-constructions, Vat (1997:70) claims that, although their acceptability depends on factors that are not well understood, they are grammatical, and Odijk (1998:204) gives them as unacceptable. According to our own intuitions examples like (67a) are acceptable but normally less preferred than examples like (66a).

- (67) a. %Jan<sub>i</sub> [<sub>clause</sub> ik heb die<sub>i</sub> nog niet gezien]. [hanging-topic LD]  
 Jan I have DEM yet not seen
- b. JAN<sub>i</sub> [<sub>clause</sub> die<sub>i</sub> heb ik t<sub>i</sub> nog niet gezien]. [contrastive LD]  
 Jan DEM have I yet not seen  
 'Jan I haven't seen him yet.'

It is, however, clear that we cannot categorically say that resumptive demonstratives are excluded in the middle field of the clause, as they can remain *in situ* in constructions that do not allow *wh*-movement like the *yes/no* question in (68a) or the imperative construction in (68b); cf. Paardekooper (1986:39), Van Riemsdijk & Zwarts (1997:21), Zaenen (1997), Odijk (1998:205) and Ott (2014:274). The same holds for constructions in which the sentence-initial position must be occupied by some other element, such as *wie* ‘who’ in the embedded *wh*-question in (68a’); cf. Paardekooper (1986:39) and Van Riemsdijk (1997:4).

- (68) a. Dat boek, heb je dat/het nog niet gelezen? [yes/no-question]  
 that book have you DEM/it yet not read  
 ‘That book, haven’t you read it yet?’  
 a’. Dat boek, wie heeft dat/het gelezen? [wh-question]  
 that book who has DEM/it read  
 ‘That book, who has read it?’  
 b. Dat boek, lees dat/het nou eens! [imperative]  
 that book read DEM/it PRT PRT  
 ‘that book, just read it!’

#### V. Island-sensitivity

The previous subsection has shown that resumptive personal pronouns preferably remain *in situ* if they are referential while the resumptive demonstratives preferably undergo *wh*-movement if the clause-initial position is available as a landing site. Although this formulation intentionally leaves some room for variation, it seems beyond doubt that the two LD-constructions differ with respect to *wh*-movement; *wh*-movement is not involved in the hanging-topic construction while it is involved in the contrastive construction. This is also reflected in the island-sensitivity of the two constructions. The examples in (37), repeated here as (69), show that the hanging-topic and contrastive LD-constructions are equally acceptable if the (trace of the) resumptive pronoun is contained in a clausal complement of a °bridge verb.

- (69) a. Jan<sub>i</sub>, [Ik denk [dat zij hem<sub>i</sub> nog niet gezien heeft]]. [hanging-topic LD]  
 Jan I think that she him yet not seen has  
 ‘Jan, I think she hasn’t seen him yet.’  
 b. JAN<sub>i</sub>, [die<sub>i</sub> denk ik [dat zij t<sub>i</sub> nog niet gezien heeft]]. [contrastive LD]  
 Jan DEM think I that she yet not seen have  
 ‘Jan, I think she hasn’t seen him yet.’

The acceptability of two constructions differs sharply, however, if the embedded clause is an island for *wh*-movement. The examples in (70) first illustrate this for interrogative complement clauses (so-called *wh*-islands): while the hanging-topic LD-constructions in (70a) is fully acceptable, the contrastive LD-constructions in the (70b) is severely degraded.

- (70) a. Jan<sub>i</sub>, [Ik weet niet [wie (of) hem<sub>i</sub> geholpen heeft]]. [hanging-topic LD]  
 Jan I know not who COMP him helped has  
 ‘Jan, I don’t know who has helped him.’  
 b. \*JAN<sub>i</sub>, [die<sub>i</sub> weet ik niet [wie (of) t<sub>i</sub> geholpen heeft]]. [contrastive LD]  
 Jan DEM know I not who COMP helped has

The examples in (71) illustrate the same contrast for an adverbial clause, which constitutes a so-called adjunct island. The examples in (72) provide similar cases involving the coordinate structure constraint.

- (71) a. Jan<sub>i</sub>, ik ben bedroefd [omdat ik hem<sub>i</sub> niet gezien heb]. [hanging-topic LD]  
 Jan I am sad because I him not seen have  
 ‘Jan, I am sad because I haven’t seen him.’  
 b. \*JAN<sub>i</sub>, die ben ik bedroefd [omdat ik t<sub>i</sub> niet gezien heb]. [contrastive LD]  
 Jan DEM am I sad because I not seen have
- (72) a. Jan<sub>i</sub>, ik heb [hem<sub>i</sub> en zijn vrouw] niet gezien. [hanging-topic LD]  
 Jan, I have him and his wife not seen  
 ‘Jan, I haven’t seen him and his wife.’  
 b. \*JAN<sub>i</sub>, die<sub>i</sub>, heb ik [t<sub>i</sub> en zijn vrouw] niet gezien. [contrastive LD]  
 Jan DEM have I and his wife not seen

That contrastive LD is island-sensitive follows immediately from the fact that the resumptive demonstrative is subject to *wh*-movement. That hanging-topic LD is not island-sensitive is due to the fact that referential personal pronouns can generally take any (non-local) discourse-prominent element as their antecedent.

#### VI. *Pied piping and stranding*

The fact that *wh*-movement of resumptive distal demonstratives is near-obligatory if the sentence-initial position is available, combined with the fact that this movement is island-sensitive, raises the expectation that contrastive LD may trigger °pied piping, and this is indeed what we find. In (73a), LD only requires movement of the possessive demonstrative *diens* but since a prenominal possessor cannot be extracted from its noun phrase, the complete noun phrase *diens vader* is moved into clause-initial position. In (73b), we see a case in which the demonstrative *diens* pied-pipes a PP.

- (73) a. JAN<sub>i</sub>, [diens<sub>i</sub> vader]<sub>j</sub> heb ik gisteren t<sub>j</sub> ontmoet.  
 Jan DEM father have I yesterday met  
 ‘Jan, I met his father yesterday.’  
 b. JAN<sub>i</sub>, [op diens<sub>i</sub> goedkeuring]<sub>j</sub> wacht ik al een lange tijd t<sub>j</sub>.  
 Jan for DEM approval wait I already a long time  
 ‘Jan I have been waiting for his approval for a long time.’

Pied piping of PPs in contrastive LD-constructions is nevertheless less common than in *wh*-questions due to the fact that [-HUMAN] demonstrative pronouns are virtually exceptionlessly subject to °R-pronominalization, while [+HUMAN] interrogative pronouns are not.

- (74) a. op wie<sub>[+human]}</sub> ⇒ waarop a'. op wat<sub>[-human]}</sub> ⇒ waarop  
 for who for what  
 b. op die<sub>[+human]}</sub> ⇒ daarop b'. op dat<sub>[-human]}</sub> ⇒ daarop  
 for that for that

Since regular pronouns like *wie* cannot be extracted from PP-objects but the prepositional part of pronominal PP-objects is often stranded, we find the following contrast between *wh*-questions and contrastive LD-constructions.

- (75) a. [Op *wie*/\**wat*]<sub>i</sub> wacht je *t*<sub>i</sub>? [[+HUMAN] only]  
 for who wait you  
 'Who are you waiting for?'  
 a'. Waar<sub>i</sub> wacht je [*t*<sub>i</sub> op]? [[-HUMAN] only]  
 what wait you for  
 'What are you waiting for?'  
 b. JAN<sub>i</sub>/HET BOEK<sub>j</sub>, [op <sup>??</sup>*die*/*\*dat*]<sub>k</sub> wacht ik *t*<sub>k</sub>. [[+HUMAN] marginally possible]  
 Jan/the book for that wait I  
 b'. JAN<sub>i</sub>/HET BOEK<sub>j</sub>, daar<sub>i/j</sub> wacht ik [*t*<sub>i/j</sub> op]. [±HUMAN]  
 Jan/the book that wait I for  
 'Jan/The book, I am waiting for him/it.'

### VII. Topicalization versus contrastive left dislocation

There is a long tradition that maintains that topicalization is a form of contrastive LD followed by deletion of the *wh*-moved resumptive demonstrative; more information on this deletion approach can be found in, e.g., Koster (1978), Weerman (1989), Kosmeijer (1993), Zwart (1997:248). Others argue against this proposal. The examples in (76) show, for example, that certain topicalization constructions do not have a LD-counterpart; the (a)-examples with a topicalized modal adverb are taken from Odijk (1995:9) and the (b)-examples with non-referential noun phrases are taken in a slightly adapted form from Van Riemsdijk & Zwarts (1997); we also have added the asterisk which was accidentally omitted from the published version.

- (76) a. Waarschijnlijk komt hij vandaag. [topicalization]  
 probably comes he today  
 'Probably he will come today.'  
 a'. \*WAARSCHIJNLIJK, dat/daar/... komt hij vandaag. [contrastive LD]  
 probably DEM comes he today  
 b. De ballen geloof ik er van. [topicalization]  
 the balls believe I there of  
 'I don't believe a word of it.'  
 b'. \*DE BALLEN, die geloof ik er van. [contrastive LD]  
 the balls DEM believe I there of

The same can be illustrated by quantified noun phrases, which were shown in Subsection II to give rise to degraded results in contrastive LD-constructions. We illustrate this in (77) by comparing examples with and without the demonstrative, which should be read, respectively, with and without an intonation break. In example (77a) the noun phrase should be interpreted as specific; topicalization is like contrastive LD in that it does not easily affect non-specific indefinites.

- (77) a. Een boek van Reve (<sup>%</sup>dat) heb ik al gelezen. [cf. (47b)]  
 a book by Reve DEM have I already read
- b. GEEN BOEK VAN REVE (\*dat) heb ik al gelezen. [cf. (49a')]  
 no book by Reve DEM have I already read
- c. VELE/ENKELE BOEKEN VAN REVE (\*die) heb ik al gelezen. [cf. (49b')]  
 many/some books by Reve DEM have I already read
- d. ALLE BOEKEN VAN REVE (<sup>??</sup>die) heb ik drie keer gelezen. [cf. (50a')]  
 all books by Reve DEM have I three times read
- e. DE MEESTE BOEKEN VAN REVE (<sup>??</sup>die) heb ik drie keer gelezen. [cf. (50b')]  
 the most books by Reve DEM have I three times read
- f. ELK BOEK VAN REVE (<sup>?</sup>dat) heb ik drie keer gelezen. [cf. (50c')]  
 each book by Reve DEM have I three times read

The examples in (78) show the same for reflexive and reciprocal pronouns. While contrastive LD of the elements gives rise to degraded results, topicalization is fully acceptable; cf. Van Riemsdijk & Zwarts (1997).

- (78) a. ZICHZELF (<sup>??</sup>die) respecteert hij niet.  
 himself DEM respects he not  
 'Himself, he doesn't respect.'
- b. ELKAAR (<sup>??</sup>die) bewonderen ze zeer.  
 each.other DEM admire they much  
 'Each other, they admire a lot.'

Another problematic case for the deletion approach can be seen in (79). The (b)-examples show that while the contrastive LD-construction is fully acceptable, the corresponding topicalization construction is rejected by many speakers; cf. Bennis & Hoekstra (1983:8). The percentage sign indicates once again that topicalization constructions of this type can be found in informal speech; cf. Klooster (1989/2001). The contrast is again unexpected if topicalization is derived by omission of the demonstrative element (here the pronominal part of the discontinuous PP *daar .. op*); see the introduction to Chapter P5 for more extensive discussion.

- (79) a. Ik ben niet dol op bananen.  
 I am not fond of bananas  
 'I am not fond of bananas.'
- b. BANANEN, daar ben ik niet dol op. [contrastive LD]  
 bananas, there am I not fond of  
 'Bananas, I am not fond of them.'
- b'. <sup>%</sup>Bananen ben ik niet dol op. [topicalization]  
 bananas am I not fond of

Note in passing that topicalization examples such as (79b') should not be confused with fully acceptable instances such as (80a), in which the noun phrase *bananen* is followed by an intonation break. Barbiers (2007:101) derives such examples as shown in (80b), that is, by means of a combination of contrastive LD and topic drop, which was discussed in Section 11.2.2. The mere fact that the acceptability

contrast between (79b') and (80a) exists can be seen as evidence against the deletion approach, although it will also be clear that the existence of the construction in (80a) has considerably obscured the discussion surrounding this hypothesis.

- (80) a. BANANEN, ben ik dol op!  
 bananas am I fond of  
 'Bananas, I am fond of them.'
- b. Bananen, [~~daar~~ ben ik dol op]. [contrastive LD + topic drop]

Odiijk (1995:9) suggests that the unacceptability of example (81b') is also problematic for the deletion approach given that it is expected that this example can be derived from (81a') by deletion of the pronominal part in clause-initial position. Odiijk's original argument is in fact more intricate, as he claims that (81b) should be unacceptable because it involves deletion of the preposition *op* in violation of the °recoverability condition on deletion; cf. Chomsky & Lasnik (1977).

- (81) a. OP BANANEN, daarop ben ik niet dol. [contrastive LD]  
 of bananas there.of am I not fond  
 'Bananas, I am not fond of them.'
- a'. OP BANANEN, daar ben ik niet dol op.  
 of bananas there am I not fond of  
 'Bananas, I am fond of.'
- b. Op bananen ben ik niet dol. [topicalization]  
 of Bananas am I not fond  
 'Bananas I am not fond of.'
- b'. \*Op bananen ben ik niet dol op.  
 of Bananas am I not fond of

Section 11.3.3, sub VI, has shown that we also find acceptability contrasts between constructions with contrastively left-dislocated and topicalized VPs; in order to avoid unnecessary redundancy we simply repeat the result of the discussion given there, and refer the reader to this section for detailed discussion.

Table 1: Topicalization and left dislocation of clauses and other verbal projections

		TOPICALIZATION	LEFT DISLOCATION
FINITE	argument (SU, DO)	✓	✓
	argument (PP)	*	✓
	adverbial	✓	*
	adverbial (conditional)	✓	✓
INFINITIVAL	<i>om</i> + <i>te</i> -infinitive	*	✓
	<i>te</i> -infinitives	?	✓
	bare infinitives	✓	✓
VP-TOPICALIZATION	past/passive participle	✓	✓
	<i>te</i> -infinitival	?	?
	bare infinitival (full)	✓	✓
	bare infinitival (remnant)	✓	?



A final empirical argument against the deletion approach might be built on examples like (82) and (83). Example (82a) first shows that left-dislocated elements can easily be followed by clause-external pragmatic markers like vocatives, the polar element *ja/nee* 'yes/no' or an interjection such as *tja* 'well'; see Haeseryn et al. (1997:1388). The acceptability of (82b) is not so telling, as it can be analyzed either as a topicalization construction or as a contrastive LD construction plus topic drop, since the intonation break is introduced here by the intervening element *nee/tja* and can thus not be used for distinguishing the construction types; see the discussion of (79b') and (80a). Since we have no other reliable tests up our sleeve, the best we can do at this point is appealing to our intuitions about this case, which point into the direction of a contrastive LD-construction with topic drop. Examples like (82b'), on the other hand, do not permit a topic drop interpretation without an intonation break after the noun phrase *dat boek*.

- (82) a. DAT BOEK<sub>i</sub>, nee/tja, dat<sub>i</sub> is hij natuurlijk vergeten. [contrastive LD]  
 that book no/well DEM is he of.course forgotten  
 'That book, no/well, he has forgotten it of course.'
- b. Dat boek, nee/tja, is hij natuurlijk vergeten. [contrastive LD + topic drop]  
 that book no/well is he of.course forgotten  
 'That book, no/well, he has forgotten it of course.'
- b'. Nee/Tja, dat boek<sub>i</sub> is hij natuurlijk vergeten. [topicalization]  
 no/well that book is he of.course forgotten  
 'No/Well, that book he has forgotten of course.'

Topicalization constructions such as (76), which do not have a contrastive LD-counterpart, perhaps show more conclusively that topicalized phrases cannot be followed by pragmatic markers like *nee* 'no' and *tja* 'well'. If these constructions were nevertheless to be some kind of contrastive LD-construction, we would expect that they can also precede the element *nee/tja*. The (a)-examples in (83) show that this expectation is not borne out; topicalized modal adverbs must follow these elements. The (b)-examples illustrate the same for cases in which a non-referential part of an idiomatic expression is preposed.

- (83) a. Nee/Tja, waarschijnlijk is hij het vergeten.  
 no/well probably is he it forgotten  
 'No/Well, probably he has forgotten it.'
- a'. \*Waarschijnlijk, nee/tja, is hij het vergeten.  
 probably no/well is he it forgotten
- b. Nee/tja, de ballen geloof ik er van.  
 no/well the balls believe I there of  
 'No/well, I don't believe a word of it.'
- b'. \*De ballen, nee/tja, geloof ik er van.  
 the balls no/well believe I there of

The discussion above has shown that despite its continuing appeal, the deletion approach meets a range of challenges; future research will have to show whether these can be met in a satisfactory way.

## VIII. Analyses of contrastive left dislocation

The previous subsections have shown that there are various differences between hanging-topic and contrastive left-dislocation. The (a)-examples in (84) illustrate again the difference in island-sensitivity on the basis of a complex noun phrase: contrastive LD but not hanging-topic LD is sensitive to this type of island. The (b)-examples, which are repeated in a slightly different form from Subsection II, show this for connectivity: while the hanging-topic LD construction does not allow a bound variable reading of the possessive pronoun *zijn* embedded in the left-dislocated phrase, this reading is available in the contrastive LD construction; the operator-variable relation is indicated by italics.

- (84) a. Jan<sub>i</sub>, ik ken [de man [die hem<sub>i</sub> geïnterviewd heeft]]. [hanging-topic LD]  
 Jan I know the man who him interviewed has  
 'Jan, I know the man who has interviewed him.'
- a'. \*JAN<sub>i</sub>, die<sub>i</sub> ken ik [de man [die t<sub>i</sub> geïnterviewd heeft]]. [contrastive LD]  
 Jan DEM know I the man who interviewed has
- b. \*[Zijn moeder]<sub>j</sub>, iedereen vindt haar<sub>j</sub> aardig. [hanging-topic LD]  
 his mother everyone considers her kind
- b'. [ZIJN MOEDER]<sub>j</sub>, die<sub>j</sub> vindt *iedereen* t<sub>j</sub> aardig. [contrastive LD]  
 his mother DEM considers everyone kind  
 'His mother everyone likes.'

The lack of island-sensitivity and connectivity in hanging-topic LD constructions follows in a natural way if we assume that left-dislocated phrases are base-generated clause-externally. One option is that each sentence has an additional position that can be filled by left-dislocated phrases; cf. Chomsky (1977). The overall structure of the sentence ( $\approx$  main clause) would then be as indicated in (85); the underlining indicates the position that is optionally filled by one or more base-generated left-dislocated phrases.

- (85) [ \_\_\_ [MAIN CLAUSE ... ] ]

The island-insensitivity of hanging-topic LD in (84a) now follows trivially from the fact that there is no movement at all. The impossibility of the bound variable reading in (84b) is due to the fact that there is no point in the derivation of the sentence at which the quantifier *iedereen* and the possessive pronoun *zijn* 'his' are in a °c-command relation; the bound variable reading is excluded for the same reason that makes a bound variable reading impossible in two consecutive sentences in a discourse: cf. \*Ik zag zijn moeder. Iedereen vindt haar aardig (the intended operator-variable relation is indicated by underlining).

The island-sensitivity of the contrastive LD construction in (84a') is due to the fact that the demonstrative pronoun is moved into the clause-initial position. However, the fact that the bound variable reading is possible in (84b') still requires various additional *ad hoc* assumptions, as there is again no point in the derivation of the sentence at which the quantifier *iedereen* and the pronoun *zijn* are in a °c-command relation. One option might be to assume that the bound variable reading is licensed by the coindexing of the left-dislocated phrase and the *wh*-moved

demonstrative, but this raises the non-trivial question as to why coindexing between a hanging topic and a referential pronoun does not have a similar effect.

The connectivity effect therefore suggests that the left-dislocated phrase has moved after all. An early proposal of this nature was given in Vat (1997), which was originally published in 1981. Vat claimed that the pronoun and the left-dislocated phrase XP form a constituent in their base position, as indicated in (86a). The full phrase is moved into the clause-initial position, as in (86b), and, finally, XP is moved into the designated position for left-dislocated phrases postulated in (85).

- (86) a. [\_\_\_ [<sub>CP</sub> ... C [<sub>TP</sub> .... [proform + XP] ...]]]  
 b. [<sub>CP</sub> [proform + XP]<sub>i</sub> C [<sub>TP</sub> ... t<sub>i</sub> ...]]  
 c. [XP]<sub>j</sub> [<sub>CP</sub> [proform + t<sub>j</sub>]<sub>i</sub> C [<sub>TP</sub> ... t<sub>i</sub> ...]]]

An attractive aspect of this proposal is that we can preserve the verb-second restriction by assuming that extraction from the clause can only proceed via the clause-initial position, a claim that is independently supported by the phenomenon of *wh*-extraction from embedded clauses; cf. Section 11.3.1.2. A potential problem for the analysis in (86) is, however, that postulation of the complex [pronoun + XP] is highly theory-dependent in the sense that it is fashioned after Vergnaud's (1974) analysis of relative clauses. This was shown to be highly problematic in Section 12.3, although there are a number of more recent incarnations of the same idea which are more plausible; see Grohmann (2003:ch.4) and De Vries (2009) for discussion. Another potential problem for Vat's analysis is that it predicts that the left-dislocated phrase and the demonstrative pronoun are adjacent, while (87) shows that they can be separated by the polar elements *ja/nee* 'yes/no', interjections and hesitation marker like *tja* 'well' and *eh* 'er', which are generally assumed to be clause-external as well; this suggests that (86c) incorrectly locates the left-dislocated phrase in a position immediately on top of CP of the main clause.

- (87) a. Dat boek, nee, dat heb ik niet gelezen.  
 that book no DEM have I not read  
 'That book, no, I haven't read it.'  
 a'. Dat boek, ja, dat heb ik inderdaad gelezen.  
 that book yes DEM have I indeed read  
 'That book, yes indeed, I have read it.'  
 b. Dat boek, tja, dat moet ik inderdaad eens lezen.  
 that book, well, DEM must I indeed once read  
 'That book, well, indeed, I should read it some time.'  
 c. Dat boek, eh, dat heb ik niet gelezen.  
 that book, er DEM have I not read  
 'That book, er, I haven't read it.'

This problem can perhaps be solved by the *wh*-movement analysis of contrastive LD proposed in Ott (2014), which does not postulate a complex phrase [*proform* + *XP*]. Ott proposes instead that contrastive LD-constructions are biclausal; they consist of two juxtaposed clauses, the first of which is partly elided under identity with the second clause. Example (88a) receives the analysis in (88a'), in which the element &: marks a phonetically empty conjunction with a specifying meaning. A major advantage of this type of analysis is that the ellipsis operation in (88a') is

independently needed in order to account for the existence of fragment clauses such as the fragment answer in (88b); see Section 5.1.5 for extensive discussion.

- (88) a. Dat boek, dat heb ik gelezen.  
 that book DEM have I read  
 ‘That book, I have read it.’  
 a’. [Dat boek<sub>i</sub> ~~heb ik t<sub>i</sub> gelezen~~] &: [dat<sub>i</sub> heb ik t<sub>i</sub> gelezen].  
 b. Welk boek heb je gelezen?  
 which book have you read  
 ‘Which book have you read?’  
 b’. *Hersenschimmen* van J.Bernlef<sub>i</sub> ~~heb ik t<sub>i</sub> gelezen~~.  
*Hersenschimmen* by J.Bernlef have I read

If the juxtaposition postulated in Ott’s analysis is indeed similar to coordination, the problem illustrated by (87) may receive a natural explanation as the clause in the second conjunct can easily be preceded by similar clause-external elements in speech.

- (89) a. Ik ging naar binnen en, ja, daar zat ze!  
 I went to inside and yes there sat she  
 ‘I went inside and, yes, there she was!’  
 a’. Ik dacht de oplossing te hebben, maar, nee, het werkte niet.  
 I thought the solution to have but no it worked not  
 ‘I though I had the solution but, no, it didn’t work.’  
 b. Hij wou weg, maar, tja, wat kan je daaraan doen?  
 he wanted away but well what can you about.that do  
 ‘He wanted to leave, but, well, what can you do about that?’  
 c. Hij wou weg, maar, eh, wat kan je daaraan doen?  
 he wanted away but er what can you about.that do  
 ‘He wanted to leave, but, er, what can you do about that?’

Another potential advantage of Ott’s proposal is that similar analyses have been put forward for split extraposition (cf. Section 12.4) and certain forms of right dislocation (cf. Section 14.3). In as far as these analyses are successful, Ott’s analysis of contrastive LD is independently supported.

As the discussion on the proper analysis of contrastive LD is still ongoing, we have to await future research before we can reach a firm conclusion. We want to conclude this section, however, with a potential problem for *all* proposals reviewed in this subsection. Subsection VI has shown that contrastive LD is compatible with preposition stranding: this is illustrated again in (90a). The problem is that for most Dutch speakers preposition stranding gives rise to a degraded result in *wh*-movement constructions such as (90b&c).

- (90) a. Dit boek<sub>i</sub>, daar<sub>i</sub> heeft hij weken [<sub>PP</sub> t<sub>i</sub> op] gewacht. [contrastive LD]  
 this book that has he weeks for waited  
 ‘This book, he has been waiting for it for weeks.’  
 b. \*Welk boek<sub>i</sub> heeft hij weken [<sub>PP</sub> op t<sub>i</sub>] gewacht? [*wh*-question]  
 which book has he weeks for waited  
 c. \*Dit boek<sub>i</sub> heeft hij weken [<sub>PP</sub> op t<sub>i</sub>] gewacht. [topicalization]  
 this book has he weeks for waited

According to the hypothesis in (86), the structure of (90a) is as given in (91a) in which the complex phrase [*daar + het boek*] is extracted from the *op*-PP. If we assume this to be possible, it becomes a mystery why the simpler noun phrase *welk boek/welk boek* in (90b&c) cannot be extracted, as this would result in the simpler structures in (91b&c).

- (91) a. [Dit boek<sub>j</sub> [<sub>CP</sub> [*daar + t<sub>j</sub>*]<sub>i</sub> heeft [<sub>TP</sub> hij weken [<sub>PP</sub> op *t<sub>j</sub>*]<sub>j</sub> gewacht]]]. [contr. LD]  
 b. [<sub>CP</sub> Welk boek<sub>i</sub> heeft [<sub>TP</sub> hij weken [op *t<sub>i</sub>*] gewacht]]? [*wh*-question]  
 c. [<sub>CP</sub> Dit boek<sub>i</sub> heeft [<sub>TP</sub> hij weken [op *t<sub>i</sub>*] gewacht]]. [topicalization]

The contrast in (90) might also be a problem for Ott's (2014) analysis. The contrastive LD construction in (90a) would have to be analyzed as in (92a), and the problem is that the structure of the first conjunct is precisely the same as the one normally assumed for the unacceptable topicalization construction in (90c). At first sight this may seem bad news, but there is also good news, as Ott's analysis leads us to expect that we find same problem in fragment answers such as (92b').

- (92) a. [Dit boek<sub>i</sub> ~~heeft hij weken [op *t<sub>i</sub>*]-gewacht~~] &: [contrastive LD]  
 [<sub>CP</sub> *daar<sub>i</sub>* heeft hij weken [op *t<sub>i</sub>*] gewacht].  
 b. Waar<sub>i</sub> heeft hij [*t<sub>i</sub>* op] gewacht? [question]  
 where has he for waited  
 'What has he been waiting for?'  
 b'. Dat boek ~~heeft hij [op *t<sub>i</sub>*]- gewacht~~. [answer]  
 that book has he for waited  
 'That book.'

This means that we are dealing with the more general problem discussed in Section 5.1.5, sub IB, that the ellipsis operation found in fragment clauses in one way or another cancels island violations. We will not digress on this issue, but refer the reader to Merchant (2001/2006), Ott & De Vries (2015), and references cited there for possible explanations of this fact.

### 14.3. Right dislocation

This section discusses two types of right dislocation (henceforth: RD), which are illustrated in example (93). Semantically, RD is characterized by the fact that the dislocated phrase adds more specific information to what is said in the preceding clause: in (93), the right-dislocated phrases provide more information about the function of Mr Jansen: he is a manager in some presupposed organization. The two types of RD differ in that AFTERTHOUGHTS provide additional information that is new for the hearer while BACKGROUNDED phrases provide information already familiar to the hearer but which may help him to identify the intended reference; cf. Ott & De Vries (2015). Furthermore, afterthoughts but not backgrounded phrases can often be preceded by a special marker such as *je weet wel* 'you probably know who': *Ik heb dhr. Jansen gesproken, je weet wel, de DIRECTEUR*.

- (93) a. Ik heb dhr. Jansen gesproken, de DIRECTEUR. [afterthought RD]  
 I have Mr Jansen spoken the manager  
 'I have spoken to Mr Jansen, the manager.'

- b. Ik heb dhr. Jansen gespröken, de directeur. [backgrounding RD]  
 I have Mr Jansen spoken the manager  
 ‘I have spoken Mr Jansen, the manager.’

Speakers’ judgments seem to differ with respect to the question as to whether the clause-internal correlate of an afterthought can be a weak proform. For some speakers (including the second author of this work) substituting the direct object in the afterthought construction (93a) results in a degraded result, while it is easily possible in the backgrounding construction in (93b). In the remainder of this work we will follow the more permissive variety, according to which examples in (94) are both fully acceptable. We leave it to future research to investigate the differences in speakers’ judgment in more detail.

- (94) a. <sup>%</sup>Ik heb ’m gespröken, de DIRECTEUR. [afterthought RD]  
 I have him spoken the manager  
 ‘I have spoken him, the manager.’  
 b. Ik heb ’m gespröken, de directeur. [backgrounding RD]  
 I have him spoken the manager  
 ‘I have spoken him, the manager.’

Phonetically, RD constructions are characterized by the fact that the right-dislocated phrase cannot receive sentence accent (indicated by a grave accent in the examples above); this accent is always located on some element in the preceding clause. That sentence accent cannot be placed on the right-dislocated phrase is related to the fact that the latter can be preceded by an intonation break: in the case of afterthoughts this break is normally distinctly present while, at least in casual speech, it is often less prominent in the case of backgrounding. The two types of RD also differ in that afterthoughts are assigned contrastive accent (indicated by small caps), while backgrounded phrases are normally pronounced with a flat intonation contour (that is, without a prominent accent).

This section is organized as follows. Subsection I starts by showing that RD resembles left dislocation (LD) in various respects. Subsection II continues by briefly reviewing a number of differences between RD and extraposition; this partly repeats information which was discussed in more detail in Chapter 12, to which we refer the reader for more information. Subsection III discusses a number of restrictions on right-dislocated phrases and their clause-internal correlate (if present). Subsection IV continues by discussing a number of differences between afterthought RD and backgrounding RD; we will see that these can be traced back to the fact that afterthoughts provide discourse-new while backgrounded phrases provide discourse-old information. Subsection V shows that RD resembles hanging-topic LD in that it is not sensitive to various islands for *wh*-extraction and Subsection VI discusses a number of word order issues related to RD. Subsection VII, finally, discusses some possible theoretical approaches to RD.

### *I. A brief comparison between left and right dislocation*

The two types of RD constructions, illustrated again in the (a)-examples in (95), resemble in various respects the two types of LD constructions discussed in Section 14.2, which are illustrated in the (b)-examples.

- (95) a. Ik heb hem gesprøken, de DIRECTEUR. [afterthought RD]  
 I have him spoken the manager  
 ‘I spoke to him, the manager.’
- a’. Ik heb hem gesprøken, de directeur. [backgrounding RD]  
 I have him spoken the manager  
 ‘I spoke to him, the manager.’
- b. De DIRECTEUR, die heb ik gesproken. [contrastive LD]  
 the manager DEM have I spoken  
 ‘The manager, I have spoken to him.’
- b’. De directeur, ik heb hem gesproken. [hanging-topic LD]  
 the manager I have him spoken  
 ‘The manager, I have spoken to him.’

First, all four types of dislocated phrases in (95) seem to be clause-external, as all of them have a clause-internal pronominal associate, namely the pronouns *hem* ‘him’ and *die* ‘that’. The fact that the °thematic role of the verb is assigned to the pronoun suggests that the dislocated phrases are not licensed within the clause but in some other way. That the dislocated phrases are not part of the clause is also supported by the fact that (like parentheticals) they are separated from the intonation contour of the clause, which, at least in the case of afterthoughts and contrastive left-dislocated phrases, goes hand-in-hand with a distinct intonation break. More reasons for assuming that dislocated phrases are clause-external are that left-dislocated phrases precede the sentence-initial position and that right-dislocated phrases cannot be assigned sentence accent, which is again indicated by a grave accent in the (a)-examples.

Secondly, all four types of dislocated phrases provide more specific information than their clause-internal associate: in (95), they all provide information about the function of the person referred to by the pronoun.

Thirdly, LD and RD both come in two types: one type in which the dislocated phrase is typically accented and one in which the dislocated phrase is normally pronounced with a flat intonation contour. It should be noted, however, that contrastive LD and afterthought RD differ in that the former invites a set of alternative propositions, while the latter simply provides discourse-new information. This can be brought to light by the examples in (96): while (96a) is fully compatible with a contrastive *maar*-phrase, the use of a contrastive *maar*-phrase gives rise to a somewhat marked result in (96b). Note in passing that this example becomes acceptable if the weak referential pronoun is replaced by a contrastively stressed pronoun, but in that case the contrastive phrase is licensed by the pronoun and not by the afterthought.

- (96) a. JAN, die heb ik niet gezien (maar MARIE wel). [contrastive LD]  
 Jan DEM have I not seen but Marie AFF  
 ‘Jan, I haven’t seen him, but I did see Marie.’
- b. Ik heb ’m niet gezien, JAN, (°)maar MARIE wel). [afterthought RD]  
 I have him not seen Jan but Marie AFF  
 ‘I haven’t seen him, Jan.’



Finally, example (97a) shows that right-dislocated phrases may provide information that may help the speaker to identify the intended reference of the clause-internal nominal correlate, but example (97b) shows that the right-dislocated phrase may also be an epithet. If the nominal correlate is predicative, as in (97c), the right-dislocated phrase provides a more precise qualification.

- (97) a. dat hij te laat kwam, mijn broer.  
that he too late came my brother  
'that he arrived too late, my brother.'
- b. dat Peter te laat kwam, de sukkel.  
that Peter too late came the twerp  
'that Peter came too late, the twerp.'
- c. dat Jan een groot kunstenaar is, de beste schilder die ik ken.  
that Jan a great artist is the best painter that I know  
'that Jan is a great artist, the best painter I know.'

The fact that left-dislocated phrases do not seem to have such "modifying" function is the principal reason why we will use different notions for the relation between the left and right-dislocated phrases and their clause-internal associate: RESUMPTION versus CORRELATION. Left-dislocated phrases provide information that is simply taken up again by their clause-internal associate, while right-dislocated phrases provide more specific information than their clause-internal associate (or about it).

## II. Right dislocation versus extraposition

Right-dislocated and extraposed phrases both follow the verbs in clause-final position; consequently, it may sometimes be difficult to distinguish the two cases. In the case of nominal arguments, confusion will not easily arise because extraposition of such arguments is normally not possible. One example is given in (98); for more examples, see 12.2, sub I.

- (98) Ik heb <de directeur > gesproken < \*de directeur >. [extraposition]  
I have the manager spoken  
'I have spoken to the manager.'

Furthermore, nominal arguments are generally obligatorily present, as a result of which right-dislocated nominal phrases will typically have an overt clause-internal correlate, as in (93) and the (a)-examples in (95). That means that right-dislocated nominal phrases without a correlate are only expected in the case of pseudo-intransitive verbs and (optional) indirect objects. Example (99) shows that the former case indeed occurs, but only if the right-dislocated phrase functions as an afterthought, that is, if it is accented and provides new information.

- (99) Jan heeft altijd graag gerookt, SIGAREN/\*sigaren. [RD]  
Jan has always gladly smoked cigars/cigars  
'Jan has always liked to smoke, cigars.'

That we are dealing with a right-dislocated phrase in (99) is immediately clear from its position after the clause-final verb *gerookt* 'smoked'. However, if no clause-final verb is present, as in the examples in (100), confusion could arise with cases in which the object occupies its regular position in the middle field of the clause, but

the intonation pattern normally provides sufficient information to distinguish the two: the direct object in (100a) is integrated in the intonation contour of the clause and can carry sentence accent; the afterthought in (100b) is preceded by an intonation break and assigned contrastive accent while the sentence accent is assigned to some other element in the preceding clause.

- (100) a. Jan rookt graag (\*vooral) sigàren. [object occupies the middle field]  
 Jan smokes gladly especially cigars  
 ‘Jan likes to smoke cigars.’
- b. Jan ròòkt graag, (vooral) SIGAREN. [RD]  
 Jan smokes gladly especially cigars  
 ‘Jan likes to smoke, (especially) cigars.’

The distribution of the focus particle *vooral* ‘especially’ can also be used as a test for recognizing RD in examples such as (100). The examples in (101) show that afterthoughts can easily be preceded by this element if the clause-internal correlate is indefinite or not present.

- (101) a. Jan heeft veel boeken gekocht, vooral ROMANS.  
 Jan has many books bought especially novels  
 ‘Jan has bought many books, especially novels.’
- b. Jan heeft altijd graag gerookt, vooral SIGAREN.  
 Jan has always gladly smoked especially cigars  
 ‘Jan has always liked to smoke, especially cigars.’

Clause-internal phrases, on the other hand, can only be preceded by a focus particle if they are scrambled into a designated focus position, which precedes manner adverbs such as *graag* ‘gladly’; cf. (102). The fact that *vooral* can immediately precede the direct object *sigaren* in (100b) but not in (100a) therefore supports the proposed analysis.

- (102) a. dat Jan <vooral ROMANS> graag <\*vooral ROMANS> leest.  
 that Jan especially novels gladly reads  
 ‘that Jan especially likes to read novels.’
- b. dat Jan <vooral SIGAREN> graag <\*vooral SIGAREN> rookt.  
 that Jan especially cigars gladly smokes  
 ‘that Jan especially likes to smoke cigars.’

The second case in which a right-dislocated nominal phrase may be expected to occur without an overt correlate pertains to ditransitive constructions without an (overt) indirect object, but it seems that such cases do not occur. Example (103b) shows that they are degraded regardless of whether the right-dislocated phrase expresses new or old information; this may be due to the fact that the alternative with a prepositional indirect object in (103b’) is preferred.

- (103) a. dat Jan (zijn vrouw) graag bloemen geeft.  
 that Jan his wife gladly flowers gives  
 ‘that Jan likes to give (his wife) flowers.’

- b. dat Jan graag bloemen geeft, (vooral) zijn <sup>??</sup>VROUW/\*vrouw. [RD]  
 that Jan gladly flowers gives especially his wife/wife
- b'. dat Jan graag bloemen geeft, (vooral) aan zijn VROUW. [RD]  
 that Jan gladly flowers gives especially to his wife  
 'Jan likes to give flowers, especially to his wife.'

Because prepositional indirect objects can be extraposed, confusion between extraposition and RD may arise in such cases, but again the intonation contour will generally provide sufficient information to identify the two cases (cf. Ott & De Vries 2015): the extraposed prepositional indirect object in (104a) is integrated in the intonation contour of the clause and can even carry sentence accent; the afterthought in (104b) is separated from the preceding clause by a distinct intonation break and is assigned contrastive accent. The two cases again differ in that only the latter can be preceded by the marker *vooral*.

- (104) a. dat Jan graag bloemen geeft (\*vooral) aan zijn vrouw. [extraposition]  
 that Jan gladly flowers gives especially to his wife  
 'Jan likes to give flowers to his wife.'
- b. dat Jan graag bloemen geeft, (vooral) aan zijn VROUW. [RD]  
 that Jan gladly flowers gives especially to his wife  
 'Jan likes to give flowers, especially to his wife.'

Prepositional objects that are obligatorily realized will not pose any problems either. The examples in (105) show that in such cases right-dislocated PPs typically have an overt clause-internal correlate, while extraposed PPs cannot be combined with such correlates. Observe that in the case of prepositional objects, the right-dislocated phrase need not be an afterthought but can also be backgrounded.

- (105) a. dat Jan (\*ernaar) verlangt naar vakantie. [extraposition]  
 that Jan for.it longs for vacation  
 'that Jan is longing for a vacation.'
- b. dat Jan \*(ernaar) verlangt, naar VAKANTIE/vakantie. [RD]  
 that Jan for.it longs for vacation/vacation  
 'that Jan is longing for.it, for a vacation.'

If the prepositional object is optional, as in the case of *wachten (op)* 'to wait for', similar problems may arise as with pseudo-intransitive verbs in that we mainly have to rely on the intonation pattern of the construction if the correlate of the right-dislocated PP is not overtly expressed.

- (106) a. dat Jan al weken (\*erop) wacht op zijn boeken. [extraposition]  
 that Jan already weeks for.it waits for his books  
 'that Jan is already waiting for weeks for his books.'
- b. dat Jan al weken (erop) wacht, op zijn BOEKEN/boeken. [RD]  
 that Jan already weeks for.it waits for his books/books  
 'that Jan has already been waiting for weeks, for his books.'

Fortunately, there is an additional syntactic test that may help us distinguish extraposition from RD, namely  $^{\circ}$ VP-topicalization. While extraposed phrases can be piped under VP-topicalization, right-dislocated phrases are generally stranded.

- (107) a. [<sub>VP</sub> Wachten op zijn boeken] doet hij al weken. [extraposition]  
 wait for his books does he already weeks  
 b. [<sub>VP</sub> Wachten] doet hij al weken, op zijn BOEKEN/boeken. [RD]  
 wait does he already weeks for his books/books  
 b'. \*<sub>VP</sub> Wachten, op zijn BOEKEN/boeken] doet hij al weken. [RD]  
 wait for his books does he already weeks

Adverbial PPs pose similar problems as optional prepositional objects because they are normally optional, as shown for a comitative *met*-PP in (108a) and a locative PP in (109a). Consequently, right-dislocated adverbial PPs without a correlate in the preceding clause could in principle be confused with their extraposed counterparts, but the (b)- and (c)-examples show that the two diagnostics used above, intonation and VP-topicalization, may help us make the correct distinction.

- (108) a. dat Jan graag (met Peter) schaakt.  
 that Jan gladly with Peter plays.chess  
 ‘that Jan likes to play chess (with Peter).’  
 b. dat Jan graag (\*met hem) schaakt met Peter. [extraposition]  
 that Jan gladly with him plays.chess with Peter  
 b'. [<sub>VP</sub> Schaken met Peter] doet Jan graag.  
 play.chess with Peter does Jan gladly  
 c. dat Jan graag (met hem) schaakt, met PETER/Peter. [RD]  
 that Jan gladly with him plays.chess with Peter/Peter  
 c'. [<sub>VP</sub> Schaken] doet Jan graag, met PETER/Peter.  
 play.chess does Jan gladly with Peter/Peter  
 c''. \*<sub>VP</sub> Schaken, met PETER/Peter] doet Jan graag.  
 play.chess with Peter/Peter does Jan gladly
- (109) a. dat Jan graag (op zijn club) schaakt.  
 that Jan gladly at his club plays.chess  
 ‘That Jan likes to play chess (at his club).’  
 b. dat Jan (\*daar) graag schaakt op zijn club. [extraposition]  
 that Jan there gladly plays.chess at his club  
 b'. [<sub>VP</sub> Schaken op zijn club] doet Jan graag.  
 play.chess at his club does Jan gladly  
 c. dat Jan (daar) graag schaakt, op zijn CLUB/club. [RD]  
 that Jan there gladly plays.chess at his club/club  
 c'. [<sub>VP</sub> Schaken] doet Jan graag, op zijn CLUB/club.  
 play.chess does Jan gladly at his club/club  
 c''. \*<sub>VP</sub> Schaken, op zijn CLUB/club] doet Jan graag.  
 play.chess at his club/club does Jan gladly

Some clausal constituents such as °supplementives cannot be extraposed while they can be right-dislocated. This can also be brought to light more clearly by means of VP-topicalization as they cannot be pied-piped if they are in postverbal position.

- (110) a. Jan is daarnet <kwaad> weggelopen <\*kwaad>. [no extraposition]  
 Jan is just.now angry away-walked  
 ‘Jan walked away angry just now.’
- a'. [<sub>VP</sub> <kwaad> weggelopen <\*kwaad>] is Jan daarnet.  
 angry away-walked is Jan just.now
- b. Jan is daarnet weggelopen, KWAAD. [RD]  
 Jan is just.now away-walked angry  
 ‘Jan walked away angry just now.’
- b'. [<sub>VP</sub> Weggelopen] is Jan daarnet, KWAAD.  
 away-walked is Jan just.now angry
- b''. \* [<sub>VP</sub> Weggelopen, KWAAD] is Jan daarnet.  
 away-walked angry is Jan just.now

The same pattern can be seen in various types of (especially non-prepositional) adverbial phrases headed by a manner adverb such as *zorgvuldig* ‘carefully’, a temporal adverb such as *morgen* ‘tomorrow’, or a modal adverb such as *misschien* ‘maybe’. It can again be brought to light by means of VP-topicalization as these modifiers must be stranded, as illustrated in (111) for the manner adverb *zorgvuldig* ‘carefully’.

- (111) a. Jan heeft het boek <zorgvuldig> gelezen <\*zorgvuldig>. [no extraposition]  
 Jan has the book carefully read  
 ‘Jan has read the book carefully.’
- a'. [<sub>VP</sub> zorgvuldig gelezen] heeft Jan het boek.  
 carefully read has Jan the book
- b. Jan heeft het boek gelezen\*(,) ZORGVULDIG. [RD]  
 Jan has the book read carefully
- b'. [<sub>VP</sub> gelezen] heeft Jan het boek, ZORGVULDIG.  
 read has Jan the book carefully
- b''. \* [<sub>VP</sub> gelezen, ZORGVULDIG] heeft Jan het boek.  
 read carefully has Jan the book

Because the two diagnostics have been more systematically applied to a wider range of constructions in our discussion of extraposition, we will not digress on this issue any further here but refer the reader to Chapter 12 for more discussion.

### III. Restrictions on right-dislocated phrases and their clause-internal correlates

Backgrounded phrases resemble hanging topics in that they are pronounced with a flat intonation contour, but the examples in (112) show that they are more flexible with respect to their categorial status; while hanging topics are typically nominal in nature, backgrounded phrases can be nominal, clausal, adjectival, or adpositional. The examples in (112) also show that the clause-internal correlate of the backgrounded phrase may perform various syntactic functions: it can be an argument, as in the (a)-examples, a complementive (112b), or an adverbial phrase (112c). The correlate is typically a phonetically light element, like the pronouns *m* ‘him’ and *het* ‘it’ or the R-word *er* ‘there’, although the phonetically heavier demonstrative forms like *die/dat* ‘that’ and *daar* ‘there’ are occasionally found as well.

- (112) a. Ik heb 'm niet meer gezien, Peter. [noun phrase]  
 I have him not anymore seen Peter  
 'I haven't seen him anymore, Peter.'
- a'. Hij heeft 't me gisteren verteld, dat hij vertrekt. [clause]  
 he has it me yesterday told that he leaves  
 'He told it to me yesterday, that he is leaving.'
- b. Ik ben 't mijn hele leven geweest, gelukkig. [AP]  
 I am it my whole life been happy  
 'I have been it my whole life, happy.'
- c. Ik ben er gisteren nog geweest, in Utrecht. [PP]  
 I am there yesterday PRT been in Utrecht  
 'I was there yesterday, in Utrecht.'

Judgments on the examples in (112) do not seem to change if we assign contrastive accent to the right-dislocated phrase, that is, afterthoughts have the same properties as backgrounded phrases, but the correlate can more easily be heavy or phrasal. This is illustrated in (113).

- (113) a. Ik heb die jongen niet meer gezien, PETER. [noun phrase]  
 I have that boy not anymore seen Peter  
 'I haven't seen that boy anymore, Peter.'
- a'. Hij heeft me dat gisteren verteld, dat hij VERTREKT. [clause]  
 he has me that yesterday told that he leaves  
 'He told me that yesterday, that he is leaving.'
- b. Ik ben dat eigenlijk mijn hele leven geweest, GELUKKIG. [AP]  
 I am it in.fact my whole life been happy  
 'I have in fact been that my whole life, happy.'
- c. Ik ben daar gisteren nog geweest, in UTRECHT. [PP]  
 I have there yesterday PRT been in Utrecht  
 'I have been there yesterday, in Utrecht.'

Right-dislocated phrases add to the information expressed by their correlates: (114a) presupposes that the hearer does not know that Mr Jansen is the manager, and (114b) suggests that the hearer may confuse the intended referent with someone who is not the manager. The right-dislocated phrase and its correlate can be interchanged but then it is presupposed that the hearer does not know the name of the manager or may confuse the intended referent with someone who is not called Jansen.

- (114) a. Ik heb dhr. Jansen gesproken, de DIRECTEUR. [afterthought RD]  
 I have Mr Jansen spoken the manager  
 'I have spoken to Mr Jansen, the manager.'
- b. Ik heb dhr. Jansen gesproken, de directeur. [backgrounding RD]  
 I have Mr Jansen spoken the manager  
 'I have spoken to Mr Jansen, the manager.'

The examples in (115) show that afterthoughts of the type in (114a) can surface in German either as an accusative or as a nominative noun phrase. The two cases have a slightly different meaning, which Ott & De Vries (2015: Section 6) try to clarify

by means of the paraphrases which are given here as translations: in the first case, the referent of the correlate is contextually given and the afterthought simply provides more specific information about this referent; in the second case, the correlate may introduce a new referent into the discourse, and the afterthought is used to identify this referent as the speaker's neighbor. Because of this difference in meaning, Ott & De Vries refer to these cases as, respectively, specificational and predicative afterthoughts, and provide different analyses for the two cases. The same meaning difference is found in Dutch, but since Dutch has no morphological case we will largely ignore predicative afterthoughts in this section and refer the reader to Ott & De Vries' article for more discussion of this type. Note in passing that Van Riemsdijk (1997) and Van Riemsdijk & Zwart (1997:fn.5) observe a similar optionality in case agreement in German LD constructions, although in such constructions a mismatch in case assignment does not seem to trigger a similar predicative reading.

- (115) a. Ich habe den<sub>acc</sub> Jan getroffen, MEINEN<sub>acc</sub> NACHBAR. [specificational]  
 I have the Jan met my neighbor  
 'I have met Jan, that is, I have met my neighbor.'
- b. Ich habe den<sub>acc</sub> Jan getroffen, MEIN<sub>nom</sub> NACHBAR. [predicative]  
 I have the Jan met my neighbor  
 'I have met Jan, who is my neighbor.'

That right-dislocated phrases must provide more specific information than their clause-internal correlates also accounts for the acceptability contrast between the (a)-examples in (116): since referential pronouns and definite noun phrases both presuppose that the hearer is able to identify the intended referent, definite noun phrases are more informative due to their descriptive content, and consequently the pronoun cannot be the right-dislocated phrase. Note that we mark (116b) with a dollar sign because the construction is certainly not ungrammatical, as is clear from the fact that it becomes felicitous if the right-dislocated pronoun is accompanied by specific extra-linguistic information, such as a pointing gesture. The acceptability of (b)-examples is also expected because the two coordinated phrases provide more precise information than their clause-internal pronominal correlates.

- (116) a. Ik heb hem gesproken, de DIRECTEUR.  
 I have him spoken the manager
- a'. \$Ik heb de directeur gesproken, HEM.  
 I have the manager spoken him
- b. Jan heeft ons uitgenodigd, jou and mij.  
 Jan has us prt.-invited you and me
- b'. Jan heeft jullie uitgenodigd, jou en haar.  
 Jan has you prt.-invited you and her

Backgrounded noun phrases are generally definite noun phrases, due to the fact that they express discourse-old information. Afterthoughts, on the other hand can be indefinite provided they are more informative than their clause-internal correlates: this implies that the correlate must be indefinite as well.



- (117) a. Ik heb iets/\*hem gekocht, EEN RODE VAAS. [afterthought RD]  
 I have something/him bought a red vase  
 'I have bought something, a red vase.'
- b. \*Ik heb iets/hem gekocht, een rode vaas. [backgrounding RD]  
 I have something/him bought a red vase

The (a)-examples in (118) show that RD is like LD in that it cannot be applied to non-referential expressions; while definite noun phrases can easily be right-dislocated, quantified noun phrases cannot. The (b)-examples illustrate the same by showing that non-referential parts of idiomatic expressions resist right dislocation.

- (118) a. Ik heb de/iedere kandidaat gesproken.  
 I have the/every candidate spoken  
 'I haven spoken to the/every candidate.'
- a'. Ik heb hem gesproken, de/\*iedere kandidaat.  
 I have him spoken the/every candidate
- b. Ik geloof er de ballen van.  
 I believe there the balls of  
 'I don't believe any of it.'
- b'. \*Ik geloof ze er van, de ballen.  
 I believe them there of the balls

De Vries (2009) claims that nominal right-dislocated phrases do not exhibit connectivity effects for °binding and, at first sight, this appears indeed to be borne out by the unacceptability of example (119a): RD of reflexive/reciprocal pronouns leads to unacceptability because the pronoun is not bound by a local antecedent. However, it is not clear whether the unacceptability of (119a) is really the result of the lack of connectivity; it may also be due to the fact that under the given coindexation the referential pronoun *ze* 'them' is incorrectly bound within its local domain, the clause. This means that in order to investigate whether connectivity effects occur we have to consider more complex examples like (119b), in which the anaphor is *embedded* in a right-dislocated phrase. The acceptability status of such examples is somewhat unclear: while De Vries (2009) gives similar examples as unacceptable, we find them acceptable and certainly much better than examples such as (119a).

- (119) a. \*[Jan en Peter]<sub>i</sub> vinden ze<sub>i</sub> erg knap, zichzelf<sub>i</sub>/elkaar<sub>i</sub>.  
 Jan and Peter consider them very bright themselves/each other
- b. %[Jan en Peter]<sub>i</sub> vinden ze<sub>j</sub> erg spannend, [elkaar<sub>j</sub>; boeken]<sub>j</sub>.  
 Jan and Peter consider them very exciting each.other's books  
 'Jan and Peter consider them very exciting, each other's books.'

That connectivity effects with reflexive pronouns do occur is also clear from the fact that they may occur as an afterthought in examples such as (120a), taken from Ott & De Vries (2015); example (120b) provides a similar case with a reciprocal.

- (120) a. Jan zag iemand in de spiegel, ZICHZELF.  
 Jan saw someone in the mirror himself
- b. Jan en Peter beschuldigen alletwee iemand van fraude, ELKAAR.  
 Jan and Peter accuse both someone of fraud each.other  
 ‘Jan and Peter both accuse someone of fraud: each other.’

Example (121) shows that connectivity effects can also be demonstrated by means of °bound variable reading: De Vries (2009) claims this reading to be unavailable, but similar examples are given as fully acceptable in Ott & De Vries (2015); we agree with them.

- (121) Elke schrijver<sub>i</sub> is er trots op, [z’n<sub>i</sub> debuut].  
 every writer is there proud of his debut  
 ‘Every writer is very proud of it, his debut.’

Example (122a) suggests that connectivity effects also occur with referential expressions: the proper noun *Peter* cannot be construed as coreferential with the subject pronoun *hij* ‘he’. De Vries (2009) correctly points out, however, that this is not a telling fact because coreferentiality is also blocked if the pronoun and the proper noun occur in two subsequent clauses; linear order may be the crucial factor here.

- (122) a. \*Hij<sub>i</sub> heeft het<sub>j</sub> gelezen, [dat boek van Peter<sub>i</sub>]<sub>j</sub>.  
 he has it read that book by Peter  
 Intended reading: ‘Peter has read it, his own book.’
- b. \*Hij<sub>i</sub> heeft de boeken ontvangen, maar het boek van Peter<sub>i</sub> ontbrak.  
 he has the book received but the book by Peter was.missing  
 Intended reading: ‘Peter has received the books, but his own book was missing.’

If the correlate of a right-dislocated phrase is a non-obligatory clausal constituent, it can be omitted. Various cases were already given in Subsection II, but we illustrate this again in (123a) for a temporal adverbial phrase. Some right-dislocated phrases never have a correlate, simply because there is no proform available; this holds for modal adverbs like *misschien* ‘maybe’ in (123b).

- (123) a. Ik was (toen) erg moe, NA DIE LANGE WANDELING.  
 I was then very tired after that long walk  
 ‘I was very tired then, after that long walk.’
- b. Hij komt morgen, MISSCHIEN.  
 he comes tomorrow maybe  
 ‘He will come tomorrow, maybe.’

#### IV. Differences between afterthoughts and backgrounded phrases

Although the previous subsection has shown that afterthoughts and backgrounded phrases as well as their correlates exhibit similar behavior in various respects, there are also a number of differences; see Ott & De Vries (2015) and the references cited there. We have already mentioned that afterthoughts provide new information while backgrounded phrases express information already known to the hearer. This can

easily be shown by the question-answer pair in (124): RD of the noun phrase *Marie* is possible in the answer, but only if pronounced with a flat intonation.

- (124) a. Ken jij Marie?  
 know you Marie  
 'Do you know Marie?'  
 b. Ja, ik ken haar goed, Marie/\*MARIE.  
 yes I know her well Marie/Marie

Related to this difference in information load is that afterthoughts can be preceded by epistemic modal adverbs such as *waarschijnlijk* 'probably' if their correlates are indefinite; this option does not arise with backgrounded phrases as their correlates normally refer to entities known both to the speaker and to the hearer. For the same reason, afterthoughts but not backgrounded phrases can be combined with a modality marker like *wellicht* 'maybe' or an hesitation marker like *toch*.

- (125) a. Jan heeft iemand bezocht, waarschijnlijk MARIE. [afterthought]  
 Jan has someone visited probably Marie  
 'Jan has visited someone, probably Marie.'  
 a'. \*Jan heeft haar bezocht, waarschijnlijk Marie. [backgrounded]  
 Jan has her visited probably Marie  
 b. Jan heeft iemand bezocht, MARIE wellicht/toch? [afterthought]  
 Jan has someone visited Marie perhaps/PRT  
 'Jan has visited someone; Marie perhaps/it was Marie, wasn't it?'  
 b'. \*Jan heeft haar bezocht, Marie wellicht/toch? [backgrounded]  
 Jan has her visited Marie perhaps/PRT

As afterthoughts add more specific information to the assertion in the preceding clause, the hearer can negate the added information independently of the clause. For the same reason the afterthought can be provided by the hearer. Note that examples like (126b) show that afterthoughts can at least sometimes be independent from the clause containing their correlate; Subsection VI will provide more evidence in favor of this conclusion.

- (126) a. Jan heeft iemand bezocht, MARIE. [speaker A]  
 Jan has someone visited Marie  
 'Jan has visited someone, Marie.'  
 a'. Niet waar: hij was de hele dag thuis/het was ELS. [speaker B]  
 not true he was the whole day home/it was Els  
 'That's not true: he has been at home all day/it was Els.'  
 b. Jan heeft iemand bezocht. Ja, MARIE. [speaker A & B]  
 Jan has someone visited yes Marie  
 'Jan has visited someone. Yes, Marie.'

This subsection has shown that there are a number of differences in use between afterthoughts and backgrounded phrases, which can be traced back to the role they play in the information structure of the discourse; afterthoughts provide discourse-new, while backgrounded phrase provide discourse-old information.

## V. Island-sensitivity

Section 14.2, sub V, has shown that hanging-topic LD is not island-sensitive, due to the resumptive pronoun *hem* ‘him’ remaining *in situ*. Contrastive LD is different in this respect as the resumptive demonstrative pronoun *die* must be moved into sentence-initial position; the contrast in (127) can be attributed to the fact that the demonstrative *die* is extracted from an interrogative clause.

- (127) a. Jan<sub>i</sub>, [Ik weet niet [wie (of) hem<sub>i</sub> geholpen heeft]]. [hanging-topic LD]  
 Jan I know not who COMP him helped has  
 ‘Jan, I don’t know who has helped him.’  
 b. \*JAN<sub>i</sub>, [die<sub>i</sub> weet ik niet [wie (of) t<sub>i</sub> geholpen heeft]]. [contrastive LD]  
 Jan DEM know I not who COMP helped has

Because RD is like hanging-topic LD in that it does not involve movement of the correlate of the right-dislocated phrase, we expect it not to be island-sensitive either. The examples in (128) show that this is indeed borne out for interrogative and adjunct clauses, for afterthoughts as well as backgrounded phrases.

- (128) a. Ik weet niet [wie (of) hem<sub>i</sub> geholpen heeft], JAN<sub>i</sub>/Jan<sub>i</sub>.  
 I know not who COMP him helped has Jan/Jan  
 ‘I don’t know who has helped him, Jan.’  
 b. Ik ben bedroefd [omdat ik hem<sub>i</sub> niet gezien heb], JAN<sub>i</sub>/Jan<sub>i</sub>.  
 I am sad because I him not seen have Jan/Jan  
 ‘I am sad because I haven’t seen him, Jan.’

The situation is less clear for non-clausal islands, an issue to which we will return in Subsection VII. The examples in (129) show that RD seems to be like LD in that it is not sensitive to the islandhood of PPs: the preposition can be used but is not needed. We added a percentage sign to (129b), however, because Zwart (2011:78) as well as Ott & De Vries (2015:40ff.) have claimed that the preposition must be realized; for them RD may therefore be sensitive to the islandhood of PPs. Note in passing that an anonymous reviewer of De Ott & De Vries (2015) indicated that not all Dutch speakers require a preposition to be present.

- (129) a. Jan<sub>i</sub>, ik wil op hem<sub>i</sub> niet langer wachten. [hanging-topic LD]  
 Jan I want for him no longer wait  
 ‘Jan, I don’t want to wait for him any longer.’  
 b. Ik wil op hem<sub>i</sub> niet langer wachten, <sup>%</sup>(op) JAN<sub>i</sub>/Jan<sub>i</sub>. [RD]  
 I want for him no longer wait for Jan/Jan  
 ‘I don’t want to wait for him any longer, Jan.’

The primeless examples in (130) show that there a sharp acceptability contrast between hanging-topic LD and RD if the correlate is embedded in a coordinate structure; this may suggest that RD is sensitive to the islandhood of those structures. It should be noted, however, that the primed examples show that a similar contrast is found if the correlate is simply embedded in, e.g., a direct object, which indicates that we cannot attribute the ungrammaticality to the presence of the coordinate structure.

- (130) a. Jan<sub>i</sub>, ik heb [hem<sub>i</sub> en zijn<sub>i</sub> vrouw] niet gezien. [hanging-topic LD]  
 Jan, I have him and his wife not seen  
 ‘Jan, I haven’t seen him and his wife.’
- a’. Jan<sub>i</sub>, ik heb [zijn<sub>i</sub> vrouw] niet gezien.  
 Jan, I have his wife not seen  
 ‘Jan, I haven’t seen his wife.’
- b. \*Ik heb [hem<sub>i</sub> en zijn<sub>i</sub> vrouw] niet gezien, JAN<sub>i</sub>/Jan<sub>i</sub>. [RD]  
 I have him and his wife not seen Jan/Jan
- b’. \*Ik heb [zijn<sub>i</sub> vrouw] niet gezien, JAN<sub>i</sub>/Jan<sub>i</sub>.  
 I have his wife not seen Jan/Jan

Finally, we need to point out that on the basis of example (131a) De Vries (2002) suggests that attributively used APs can be used as afterthoughts, which would of course be another example of island-insensitivity. However, Veld (1993:132ff.) already pointed out that this is only apparent: we are dealing with reduced noun phrases, as is also clear from the fact that the indefinite article *een* ‘a’ shows up obligatorily if the correlate is singular, as in (131b). Like (130b), this shows that RD is sensitive to certain non-clausal islands.

- (131) a. Jan heeft druiven gekocht, WITTE.  
 Jan has grapes bought, white  
 ‘Jan has bought grapes, white ones.’
- b. Jan heeft een auto gekocht, een WITTE.  
 Jan has a car bought, a white  
 ‘Jan has bought a car, a white one.’

## VI. Word order restrictions

Right-dislocated phrases normally follow extraposed phrases such as the obligatory prepositional object *naar meer informatie* in (132): placement of the modal adverb in a position between the clause-final verb and the extraposed PP gives rise to a degraded result. For completeness’ sake, we contrast example (132b) with example (132b’), in which the PP is right-dislocated.

- (132) a. dat Jan verlangt naar meer informatie, waarschijnlijk.  
 that Jan longs for more information probably  
 ‘that Jan probably wishes more information.’
- b. \*dat Jan verlangt, waarschijnlijk, naar meer informatie.  
 that Jan longs probably for more information
- b’. dat Jan ernaar verlangt, waarschijnlijk, naar meer informatie.  
 that Jan for.it longs probably for more information

Right-dislocated phrases also obey certain order restrictions: cf. Ott & De Vries (2015). Before illustrating this, we want to observe that backgrounded phrases and afterthoughts can be reiterated (although some speakers have difficulty with this). Note in passing that the first afterthought in (133b) is not only marked by means of accent but also by the fact that it can be preceded by *althans*; we will use this as a diagnostic in (134).

- (133) a. Jan heeft haar gezien, gisteren, die vrouw. [backgrounding RD]  
 Jan has her seen yesterday that woman  
 'Jan saw her yesterday that woman.'
- b. Jan gaat wintersporten, althans VOLGEND JAAR, SKIËN. [afterthought RD]  
 Jan goes winter.sport at.least next year skiing  
 'Jan will go on winter sports, at any rate next year: skiing.'

Backgrounded phrases and afterthoughts can also be combined but then the former must precede the latter; in tandem with our finding in Subsection IV that afterthoughts may occasionally occur as separate utterances, this shows that backgrounded phrases are more closely related with the preceding clause than afterthoughts.

- (134) a. dat ik hem morgen ontmoet, Peter, (althans) WAARSCHIJNLIJK.  
 that I him tomorrow meet Peter at.least probably  
 'that I will meet him tomorrow, Peter, at least probably.'
- b. \*dat ik hem morgen ontmoet, (althans) WAARSCHIJNLIJK, Peter.  
 that I him tomorrow meet at.least probably Peter

That backgrounded phrases are more closely related with the preceding clause is also suggested by the fact, illustrated in (135), that they must be adjacent to the *minimal clause* containing their correlate, while afterthoughts follow the *complete sentence* containing their correlate; we return to these instances in Subsection VII.

- (135) a. Dat hij weg was, Peter/?PETER, was vervelend.  
 that he away was Peter/Peter was annoying  
 'that he was away, Peter, was annoying.'
- b. Dat hij weg was, was vervelend, PETER/\*Peter.  
 that he away was was annoying Peter/Peter  
 'That he was away, was annoying, Peter.'

Although the examples in (133) have shown that backgrounded phrases and afterthoughts can be reiterated, this does not always give rise to a felicitous result. The examples in (136b&c) show that modal and temporal adverbs can easily be right-dislocated, but for unknown reasons the (d)-examples show that it is difficult to have them simultaneously in right-dislocated position.

- (136) a. dat Jan morgen waarschijnlijk vertrekt.  
 that Jan tomorrow probably leaves  
 'that Jan will probably leave tomorrow.'
- b. dat Jan morgen vertrekt waarschijnlijk.  
 c. dat Jan waarschijnlijk vertrekt morgen.  
 d. \*?<sup>?</sup>dat Jan vertrekt morgen waarschijnlijk.  
 d'. \*?<sup>?</sup>dat Jan vertrekt waarschijnlijk morgen.

### VII. Analyses of RD

While LD has received relatively much attention in the theoretical literature, this is much less so for RD. Because of the similarities between LD and RD constructions discussed in Subsection III, it seems preferable for the two types of dislocation to

receive a similar analysis. Consequently, as RD does not involve movement of the correlate of the right-dislocated phrase, this may be a good reason for dismissing the various movement approaches to contrastive LD, discussed in Section 14.2, sub VIII. This would leave us with Ott's (2014) hypothesis that contrastive LD constructions consist of two juxtaposed clauses, the first of which is reduced under identity with the second clause. Ott & De Vries (2015) go on to provide a similar analysis for RD; they argue that the derivation of RD differs from that of LD only in that the reduction does not apply to the first but to the second clause of the juxtaposition. They analyze the right-dislocated phrase in (137a) in the same way as the fragment answer in (137b), that is, the juxtaposition analysis of RD appeals to an independently motivated deletion operation.

- (137) a. Ik heb het gelezen, *Hersenschimmen* van J.Bernlef.  
 I have it read *Hersenschimmen* by J.Bernlef  
 'I have read it, *Hersenschimmen* by J.Bernlef.'
- a'. [Ik heb het gelezen] &: [*Hersenschimmen* van J.Bernlef<sub>i</sub> ~~heb ik t<sub>i</sub> gelezen~~].
- b. Welk boek heb je gelezen?  
 which book have you read  
 'Which book have you read?'
- b'. *Hersenschimmen* van J.Bernlef<sub>i</sub> ~~heb ik t<sub>i</sub> gelezen~~.  
*Hersenschimmen* by J.Bernlef have I read

A potential problem for the analysis in (137a') is that it is not very clear what would trigger topicalization in the derivation of RD. Nevertheless, Ott & De Vries (2015) claim that examples of the type in (138) provide independent evidence for topicalization. Zwart (2011:79) has noted that the two examples in (138a&b) differ in their relative scope of the indefinite subject *twee mensen* 'two persons' and the epistemic modal *vermoedelijk*: the most prominent reading of example (138a) is that the modal is in the scope of the numeral, that is, two people have seen something that is presumably a wolf. The most prominent reading of the RD construction in (138b) is that the modal takes scope over the complete proposition including the numerals, that is, it is presumably the case that two people have seen a wolf. This would follow immediately under the proposed analysis of RD because the wide scope reading of the modal is also the most prominent one for the topicalization construction in (138c).

- (138) a. Twee mensen hebben vermoedelijk een wolf gezien. [numeral > modal]  
 two persons have presumably a wolf seen  
 'Two people have presumably seen a wolf.'
- b. Twee mensen hebben een wolf gezien, vermoedelijk. [modal > numeral]  
 two persons have a wolf seen presumably  
 'Two people have seen a wolf, presumably.'
- c. Vermoedelijk hebben twee mensen een wolf gezien. [modal > numeral]  
 presumably have two persons a wolf seen  
 'Presumably, two people saw a wolf.'

Another potential problem for assuming topicalization in the second conjunct is the fact established in Subsection V that RD is not sensitive to, e.g., interrogative and



adjunct islands. Section 14.2, sub VIII, has shown, however, that this also holds for fragment clauses and LD constructions. This means that we are dealing with the more general fact discussed in Section 5.1.5, sub IB, that the ellipsis operation found in fragment clauses in one way or another cancels island violations; we refer the reader to Merchant (2001/2006), and references cited there for possible explanations of this fact.

Ott & De Vries (2015) develop an alternative to the island-insensitivity of RD by assuming that the juxtaposition involves the minimal clause of the associate of the dislocated phrase; we illustrate this here for RD only. The minimal clause restriction requires that we analyze example (139a) as in (139b); the analysis in (139b') is not available.

- (139) a. Els zei dat hij weg was, Peter.  
 Els said that he away was Peter  
 'Els said that he was away, Peter.'  
 b. Els zei [[dat hij weg was] &: [Peter ~~was weg]]].  
 b'. \*[[Els zei [dat hij weg was]] &: [Peter<sub>i</sub> zei Els [dat <sub>t<sub>i</sub></sub> weg was]]].~~

A potential drawback of relying on the minimal clause restriction is that we have to allow for coordination of embedded and main clauses; cf. the structure in (139b), in which the first conjunct is a non-main while the second conjunct is a main clause. Although this kind of unbalanced coordination is normally not possible, the minimal clause restriction is supported empirically by the fact illustrated in the primeless examples in (140) that backgrounded phrases must be adjacent to their minimal clauses; the structures in the corresponding primed examples show that this can only be derived by assuming the minimal clause restriction, otherwise, (140a) could not be derived and example (140b) would be incorrectly predicted to be acceptable.

- (140) a. Dat hij weg was, Peter, was vervelend.  
 that he away was Peter was annoying  
 'that he was away, Peter, was annoying.'  
 a'. [dat hij weg was] &: [Peter ~~was weg] was vervelend.  
 b. \*Dat hij weg was, was vervelend, Peter.  
 that he away was was annoying Peter  
 b'. \*[[dat hij weg was] was vervelend] &: [Peter<sub>i</sub> ~~was [dat <sub>t<sub>i</sub></sub> weg was] vervelend].~~~~

Example (140a) again illustrates the island-insensitivity of RD, given that *wh*-movement out of subject clauses is normally impossible; cf. \*Peter<sub>i</sub> was [dat t<sub>i</sub> weg was] vervelend. The lack of island-sensitivity follows immediately from the minimal clause restriction. We illustrate the same island-insensitivity again in (141) for an interrogative island. For completeness' sake observe that (141b') would also be unacceptable because it violates the °complementizer-trace filter; cf. *Ik weet dat Els al gegeten heeft* 'I know that Els has already eaten' versus \*Els<sub>i</sub> weet ik dat t<sub>i</sub> al gegeten heeft.

- (141) a. Ik weet niet of zij gegeten heeft, Els.  
 I know not whether she eaten has Els  
 ‘I do not know whether she has eaten, Els.’  
 b. Ik weet niet [[of zij gegeten heeft] &: [Els heeft gegeten]].  
 b'. \*[[Ik weet niet [of zij gegeten heeft]] &: [Els<sub>i</sub> weet ik niet [of <sub>i</sub> gegeten heeft]]].

Recall from Subsection VI that afterthoughts can be detached from the clause containing their correlate, that is, example (140b) becomes fully acceptable for at least some speakers if the right-dislocated phrase is contrastively stressed. This seems to be related to the fact that afterthoughts can be used as independent expressions; if afterthoughts are independent of the sentences preceding them, the minimal clause restriction cannot hold for them by definition.

The minimal clause restriction seems superior to Merchant’s analysis according to which ellipsis cancels island violations because it accounts for the fact that RD *is* normally sensitive to certain non-clausal islands, such as the coordinate structure in (142a): this follows from the fact that topicalization in the second conjunct in (142b) violates the °coordinate structure constraint (but see Ott & De Vries, 2015:fn.50, for a potential problem). The disadvantageous aspect of the minimal clause restriction is that LD does not seem to be sensitive to the coordinate structure constraint (cf. Section 14.2, sub V), which is a problem for Ott & De Vries in light of their claim that LD and RD should be analyzed in essentially the same way.

- (142) a. \*Ik heb [hem en Marie] niet gezien, Jan.  
 I have him and Marie not seen Jan  
 b. [Ik heb [hem en Marie] niet gezien] &: [Jan heb ik [<sub>i</sub> en Marie] niet gezien].

The fact that for at least some speakers RD of a prepositional object does not require the preposition to be present is another potential problem for the minimal clause restriction: because preposition stranding is not possible in the case of topicalization (cf. \**Mijn vader<sub>i</sub> wacht ik op t<sub>i</sub>*) example (143a) is predicted to be unacceptable without the preposition. But this problem is not new, as Merchant (2001:ch.3, fn.6) already found that Dutch speakers exhibit a great deal of variation with respect to preposition stranding in ellipsis constructions. The fact that we find this variation in the case of RD as well can therefore be construed as an argument in favor of unifying the analyses of fragment clauses, LD and RD. We refer the reader to Section 5.1.5, sub IB, and Section 14.2, sub VIII, for more relevant discussion.

- (143) a. %Ik wacht op hem, mijn vader.  
 I wait for him my father  
 ‘I am waiting for him, my father.’  
 b. [Ik wacht op hem] &: [mijn vader<sub>i</sub> wacht ik op <sub>i</sub>].

Recent research has made great progress in describing the properties of RD by attempting to develop a unifying account of fragment clauses, LD and RD. We have also seen that there are still a number of questions to be answered, but we have to leave these to future research.

#### **14.4. Bibliographical notes**

Pragmatic markers have received much attention in the literature on pragmatics and discourse since Schiffrin (1987). Readers interested in theoretical literature on pragmatic markers are referred to, e.g., the surveys in Blakemore (2002), Romero-Trillo (2009), and Aijmer (2002), as well as the recent collection of articles in Degand et al. (2013). Foolen & Van der Wouden (2011) provide a short survey focusing more particularly on Dutch.

Left dislocation has traditionally received a great deal of attention in the syntactic literature; cf. Paardekooper (1986:417ff.) and Haeseryn et al. (1997: Section 21.8). A set of older and more recent articles on this topic from the point of view of formal approaches to syntax is collected in Anagnostopoulou & Van Riemsdijk (1997). A brief review of the theoretical literature can be found in Alexiadou (2006) and in Section 14.2, sub VIII, which also discusses a recent proposal by Ott (2014), according to which left-dislocated phrases are derived in essentially the same way as fragment clauses.

Right dislocation has received much less attention than left dislocation in the syntactic literature; however, Ott & De Vries (2015) provides a good review of the basic properties of the construction.



## Glossary (all *SoD* volumes)

### **A- and A'-binding:**

An element is bound if it has a °c-commanding antecedent. An element is A-bound if its antecedent occupies an °argument position and A'-bound if it occupies a non-argument position. The notion of °binding refers to A-binding in the default case.

### **A- and A'-position:**

See °argument position.

### **A- and A'-movement:**

See °movement.

### **Absolute *met*-construction:**

A prepositional phrase headed by the preposition *met* 'with'. The complement of *met* consists of a noun phrase and some other category which is predicated of this noun phrase. Some examples are provided in (i); the absolute constructions are in brackets.

- (i) a. [Met Peter ziek] kunnen we die vergadering niet houden.  
with Peter ill can we that meeting not hold  
b. [Met Peter in het ziekenhuis] kunnen we die vergadering niet houden.  
with Peter in the hospital can we that meeting not hold

### **Accidental coreference:**

A notion used to refer to the fact illustrated in (ia) that a referential personal pronoun such as *hij* 'he' may be coreferential with an element used earlier in the discourse without there being a °binding relation between the two. The availability of accidental coreference in (ia) makes it unnecessary to appeal to binding in order to account for the fact that the two elements may be coreferential.

- (i) a. Jan<sub>i</sub> lachte. Hij<sub>i</sub> vond the grap leuk.  
Jan laughed he found the joke amusing  
b. Jan<sub>i</sub> beloofde dat hij<sub>i</sub> zou komen.  
Jan promised that he would come

It can nevertheless be shown that pronouns can be bound by an antecedent by taking into account referential dependencies between pronouns and quantifiers like *iedereen* 'everybody' or *niemand* 'nobody'. Example (iia) shows that accidental coreference is not possible with such quantified expressions. The fact that the pronoun can be referentially dependent on these elements in (iib) shows that binding must be involved. Since the bound pronoun has the function of a variable in predicate calculus, cases like (iib) are known as bound variable constructions.

- (ii) a. \*Iedereen<sub>i</sub>/Niemand<sub>i</sub> lachte. Hij<sub>i</sub> vond the grap (niet) leuk.  
everybody/nobody laughed he found the joke not amusing  
b. Iedereen<sub>i</sub>/Niemand<sub>i</sub> beloofde dat hij<sub>i</sub> zou komen.  
everybody/nobody promised that he would come

**Accusative case:**

The °case prototypically assigned to the theme argument of the main verb in simple clauses in the active voice. This case can also be assigned to the SUBJECT of a °complementive, or to SUBJECT of an infinitival clause in so-called °AcI-constructions. Noun phrases marked with accusative case are often referred to as direct objects. German has a set of prepositions that assign accusative case to their nominal complement; this may also be the case in Dutch but it is hard to establish due to the fact that accusative case is not morphologically distinct from dative case in Dutch.

**AcI-construction:**

The abbreviation AcI stands for *Accusativus cum Infinitivo* (accusative with infinitive). The AcI-construction is an infinitival clause in which the subject is not left implicit but realized as an accusative noun phrase. Such constructions only occur as the complement of the causative/permissive verb *laten* ‘to make/let’ and perception verbs like *zien* ‘to see’ and *horen* ‘to hear’. In (i) the accusative subject of the infinitival clause is in italics.

- (i) a. Jan laat [*het meisje/haar* een liedje zingen].  
 Jan lets the girls/her a song sing  
 b. Jan zag/hoorde [*het meisje/haar* vertrekken].  
 Jan saw/heard the girl/her leave

**Across-the-Board:**

Examples (ib&b') show that subextraction from a coordinated structure is normally excluded; cf. °Coordinate Structure Constraint. This does not hold, however, if the movement applies in a so-called Across-the-Board fashion, that is, affects all conjuncts: (ic) is acceptable due to the fact that the *wh*-phrase *wat* ‘what’ is in a sense moved from (related to an interpretative gap in) both conjuncts.

- (i) a. Jan heeft [[een boek van Peter gestolen] en [een CD/boek aan Marie gegeven]].  
 Jan has a book from Peter stolen and a CD/book to Marie given  
 b. \*Wat<sub>i</sub> heeft Jan [[*t<sub>i</sub>* van Peter gestolen] en [een boek aan Marie gegeven]]?  
 what has Jan from Peter stolen and a book to Marie given  
 b'. \*Wat<sub>i</sub> heeft Jan [[een boek van Peter gestolen] en [*t<sub>i</sub>* aan Marie gegeven]]?  
 what has Jan a book from Peter stolen and to Marie given  
 c. Wat<sub>i</sub> heeft Jan [[*t<sub>i</sub>* van Peter gestolen] en [*t<sub>i</sub>* aan Marie gegeven]]?  
 what has Jan from Peter stolen and to Marie given

**Adicity:**

The adicity (or valency) of a lexical head (verb, noun, adjective, preposition) concerns the number of arguments this lexical head takes. A monadic head takes one, a dyadic head takes two, and a triadic head takes three arguments. Lexical heads that do not take any arguments are called avalent.

**Adjunct:**

A constituent in the domain of a lexical head H that is not selected by H. An adjunct is thus distinct from an argument, which is a constituent that is selected by H. Adjuncts and arguments differ in that the former are generally optional, whereas

arguments are generally obligatorily present (or at least semantically implied). In (i), the PP *in de keuken* ‘in the kitchen’ is optional and can be considered an adjunct, whereas the NP *de aardappelen* ‘the potatoes’ is virtually obligatory, and can be considered an argument of the verb *schillen* ‘to peel’. See also °adjunction.

- (i) a. Jan schilt de aardappelen (in de keuken).  
 b. Jan schilt \*<sup>o</sup>(de aardappelen) in de keuken.  
 Jan peels the potatoes in the kitchen

### Adjunction:

A syntactic operation that creates a new position. It is often assumed, for instance, that certain °adjuncts can be attached (adjoined) to a maximal projection [<sub>XP</sub> ... X ...] leading to the structure [<sub>XP</sub> adjunct [<sub>XP</sub> ...]]. The adjunction operation is not only found in generative grammar but also in, e.g., categorial grammar, where it is also assumed that the introduction of an adjunct creates an XP if applied to an XP. The adjunction operation is not uncontroversial: Cinque (1999), for example, assumes that adjuncts are placed in the specifier position of specific functional projections.

### Adverb:

The notion adverb does not denote a set of entities with a specific categorial status, as do the notions verb, noun, adjective and preposition, but rather a set of lexical elements that can have a certain syntactic function in the clause, more specifically that of an adverbial phrase. Our use of the notion of adverb should therefore be seen as shorthand for “adverbially used adjective” given that many adverbs exhibit adjectival properties: they may be used attributively or predicatively in other contexts, or exhibit typical syntactic or morphological properties like the ones given in (i).

- (i) a. Modification by *erg/heel/zeer* ‘very’  
 b. Comparative and superlative formation  
 c. *On-* prefixation  
 d. Having an adjectivizing suffix

Despite the fact that we do not acknowledge the existence of a lexical category “adverb”, it cannot be denied that there are certain adverbs, like the °intensifiers *zeer* ‘very’ and *heel* ‘very’ mentioned in (ia), for which there is little direct syntactic or morphological evidence that they are adjectival in nature. However, the fact that they cannot normally be inflected for tense and agreement shows that they are not verbs, and the fact that they can neither be preceded by a determiner nor appear in an argument position strongly suggests that they are not nouns either. Therefore, we provisionally conclude that they must be adjectives, which is supported by the fact that they share the semantic property of being able to modify an adjective.

### Adverbial tests:

In cases of modification of a verbal projection, at least two types of adverbial phrases should be distinguished. The first type involves modification of the proposition expressed by the clause, which is therefore referred to as a clause adjunct. Clauses that contain this type of adverbial phrase can be paraphrased as in (ia); a concrete example is given in (ia’&a’). The second type involves modification



of the verb (phrase) only, and is referred to as a predicate or VP-adjunct. Clauses that contain this type of adverbial phrase can be paraphrased as in (ib), in which the pronoun must be construed as identical to the subject of the clause; a concrete example is given in (ib'&b''). See Section A8.2 for further discussion.

- (i) a. Clause adjunct: Het is ADVERB zo dat CLAUSE  
 a'. Jan werkt natuurlijk.  
 Jan works of.course  
 a''. Het is natuurlijk zo dat Jan werkt.  
 it is of.course the.case that Jan works  
 b. Predicate adjunct: [<sub>CLAUSE</sub> subject<sub>i</sub> ...] en pronoun<sub>i</sub> doet dat ADVERB  
 b'. Jan lacht hard.  
 Jan laughs loudly  
 b''. Jan<sub>i</sub> lacht en hij<sub>i</sub> doet dat hard.  
 Jan laughs and he does that loudly

### **Aktionsart:**

The notion of Aktionsart (sometimes also called INNER ASPECT) refers to the internal temporal organization of the event denoted by (the lexical projection of) a verb, and thus involves questions like (i) whether the event is construed as occurring at a single point in time (momentaneous aspect) or as evolving over time (durative aspect), (ii) whether the event is inherently bounded in time, and, if so, whether the event is bounded at the beginning (ingressive/inchoative aspect), at the end (terminative aspect) or both, (iii) whether the verb expresses a single event or a series of iterated events, etc. There are many ways of classifying verbs and verb phrases according to their Aktionsart: see Section V1.2.3.

### **Amplifier:**

See °Intensifier.

### **Anti-c-command restriction:**

Two phrases A and B are subject to this restriction if they are not allowed to °c-command each other: A cannot c-command B and B cannot c-command A.

### **Anticipatory pronoun/pronominal PP:**

Clauses may have argument status with respect to a lexical head. Generally speaking, however, they do not occur in the regular argument position, but are in extraposed position. For instance, if the argument position is part of a verbal projection, it may optionally be occupied by the pronoun *het* 'it', which is called the anticipatory pronoun, as in (ia). If the clause is part of a prepositional complement, the anticipatory pronominal PP *er*+P may optionally occur, as in (ib). See °R-extraction for a discussion of the fact that the anticipatory pronominal PP *erover* is normally split.

- (i) a. Jan betwijfelt (het) of Marie komt.  
 Jan doubts it whether Marie comes  
 'Jan doubts whether Marie will come.'  
 b. Jan is (*er*) boos (*over*) dat Marie niet komt.  
 Jan is there angry about that Marie not comes  
 'Jan is angry that Marie won't come.'

**Argument:**

An argument is a constituent in the domain of a lexical head H that is selected by H. An argument is distinct from an °adjunct, which is a constituent not selected by H. Arguments and adjuncts differ in that the former are normally obligatorily present (or at least semantically implied), whereas adjuncts are optional. In (i), the noun phrase *de aardappelen* ‘the potatoes’ is virtually obligatory and can be considered an argument of the verb *schillen* ‘to peel’, whereas the PP *in de keuken* ‘in the kitchen’ is optional and can be considered an adjunct.

- (i) a. Jan schilt \*°(de aardappelen) in de keuken.  
 b. Jan schilt de aardappelen (in de keuken).  
 Jan peels the potatoes in the kitchen

Arguments are usually associated with verbs: verbs have argument structures, specifying the number and °thematic roles of their arguments. An intransitive verb like *lachen* ‘to laugh’, for example, has one (agentive) argument, a transitive verb like *lezen* ‘to read’ has two arguments, an agent and a theme, and a ditransitive verb like *geven* ‘to give’ has three arguments. The arguments of these verbal predicates fill slots in the predicate frame implied by these verbs: *lachen* is a one-place predicate LACHEN (x) and the agentive argument fills the single argument slot; *lezen* is a two-place predicate LEZEN (x,y) and the two arguments fill the two slots in the predicate frame; *geven* is a three-place predicate and again the three arguments fill the slots in the predicate frame GEVEN (x,y,z).

- |      |   |   |
|------|---|---|
| (ii) | • Predicate   | • Example   |
| a.   | LOPEN <sub>V</sub> ( <u>Agent</u> )<br>walk                   | a'. [Jan] <sub>Agent</sub> [loopt] <sub>Pred</sub><br>Jan walks                             |
| b.   | LEZEN <sub>V</sub> ( <u>Agent</u> , Theme)<br>read            | b'. [Marie] <sub>Agent</sub> [leest een krant] <sub>Pred</sub><br>Marie reads a newspaper   |
| c.   | GEVEN <sub>V</sub> ( <u>Agent</u> , Theme, Recipient)<br>give | c'. [Jan] <sub>Agent</sub> [geeft Marie een boek] <sub>Pred</sub><br>Jan gives Marie a book |

The arguments in the predicate frame of two- and three-place predicates are not all of the same nature: filling the y and z slots in a sense completes the predicate, as a result of which it can be predicated of the argument placed in the x slot. In syntactic terms, the argument filling the x slot of a predicate normally corresponds to the subject of the clause, whereas the arguments filling the y and z slots correspond to the objects of the clause. Since the objects have the function of creating a complete predicate, they are often referred to as the °complements or INTERNAL ARGUMENTS of the verb. The subject, on the other hand, will be referred to as the EXTERNAL ARGUMENT of the verb, the argument which the complete verbal predicate is predicated of. In the lexical frames in (ii), the external argument is underlined in order to distinguish it from the complements. Note that there are several complications that are not discussed here: for instance, °unaccusative verbs are assumed not to have an external argument but to be predicated of their internal argument (cf. V2.1).

Since adjectives and nouns function as predicates as well, they also take arguments. This is shown in (iii), where the adjectival/nominal noun phrase is

predicated of the noun phrase *Jan*, which therefore functions as the first argument. Since the usual labels for semantic roles are created especially for expressing the roles of the arguments in the event structure denoted by verbal predications, we will simply refer to the first argument of non-verbal predicates as the REFERENT (Ref), that is, the entity with regard to which the property denoted by the adjectival/nominal noun applies.

- |       |   |  |
|-------|---|--|
| (iii) | • AARDIG <sub>A</sub> (Ref)   | • GENIE <sub>N</sub> (Ref)   |
| a.    | [Jan] <sub>Ref</sub> is [aardig] <sub>Pred.</sub><br>Jan is kind              | b. [Jan] <sub>Ref</sub> is [een genie] <sub>Pred.</sub><br>Jan is a genius               |
| a'.   | Ik vind [Jan] <sub>Ref</sub> [aardig] <sub>Pred.</sub><br>I consider Jan kind | b'. Ik vind [Jan] <sub>Ref</sub> [een genie] <sub>Pred.</sub><br>I consider Jan a genius |

### Argument position:

The notion argument or A-position normally refers to a position in the clause that can only be occupied by an argument of the verb. Such positions are characterized by the fact that they can be assigned specific syntactic features, the three main types of which are: °thematic roles, nominal agreement features (person, gender and number), and structural °case. Prototypical A-positions are the subject and object position. The notion non-argument or A'-position refers to a position that can also be occupied by a non-argument (adverbial phrase, etc.). Such positions function as landing sites for elements with a specific logico-semantic role (such as operator or negation) or an information-structural function (topic, focus, etc.); a prototypical A'-position is the clause-initial position into which normally any clausal constituent can be moved by *wh*-movement.

The number of A- and A'-positions postulated in generative grammar has increased considerably over the years. As for A-positions for nominal arguments of verbs, there were only two positions available in the early 1980's: the object and the subject position in the simplified structure in (ia). The object position within VP is the position to which the thematic role theme, accusative case and (for languages that have it) object agreement features can be assigned; the subject position is the position to which the thematic role agent, nominative case and the subject agreement features can be assigned. Arguments can sometimes also pick up their features in different places. In the °unaccusative structure in (ib) the subject *John* is base-generated in the object position, where it is assigned the thematic role theme, and subsequently moved into the subject position, where it is assigned nominative case and the subject agreement features. This movement is normally referred to as NP- or A-movement.

- (i) a. [<sub>S</sub> John T(ense) [<sub>VP</sub> buys the book]]  
b. [<sub>S</sub> John T(ense) [<sub>VP</sub> *t*<sub>i</sub> leaves]]

The fact that the syntactic features of a certain argument can be scattered over several positions in the clause has ultimately given rise to the hypothesis that there is a one-to-one relationship between features and positions. For example, instead of assuming that all features for the object are generated in a single position it is now assumed that these are assigned by different functional heads as in (ii), where the verb assigns the role theme, the AGR-head assigns the agreement features

and the CASE-head assigns accusative case. Note that the names used here for these functional heads are just randomly chosen: a large number of implementations of the main idea can be found in the literature since Pollock's (1989) seminal paper on this issue. Something similar to what is assumed for objects is assumed for subject.

- (ii)  $[_{XP} [\text{accusative}] \text{CASE} [_{AGRP} [\text{person, number, gender}] \text{AGR} [_{VP} [\text{theme}] \text{V}]]]$

As all A-positions in (ii) are potential landing sites for the theme argument, the number of A-movements in the derivation of sentences has vastly increased compared to the earlier proposal in (i), and the same in fact holds for verb movement, as all functional heads in (ii) are potential landings sites for the verb. There is also a proliferation of A'-positions since the seminal work by Haegeman & Zanuttini (1991), Haegeman (1995) and Rizzi (1996/1997); while in the early 1980's there was actually only one clearly defined A'-position, which was targeted by *wh*-movement, more recent research claims to have identified a large number of additional A'-positions, which can be targeted by negative phrases, focus, topic, quantified phrases, etc. Languages are claimed to differ as to whether the relevant positions are filled by (overt) movement and this has led to a line of fruitful research that has made a wealth of new cross-linguistic data available.

**Argument structure:**

See °argument.

**Atelic:**

See °telic verb.

**Binding:**

A noun phrase (typically a pronoun) is said to be bound if it is coreferential with a °c-commanding antecedent. Noun phrases differ with respect to the syntactic domain in which they must or can be bound. This is clear from the fact illustrated by the examples in (ia&b) that reflexive and referential personal pronouns like *zichzelf* and *hem* are in complementary distribution. Referential expressions like *de jongen* in (ic) normally remain free (= not bound) within their sentence.

- (i) a. Ik denk dat Jan<sub>i</sub> zichzelf<sub>i</sub>/\*hem<sub>i</sub> bewondert.  
 I think that Jan himself/him admires  
 'I think that Jan admires himself.'  
 b. Jan<sub>i</sub> denkt dat ik hem<sub>i</sub>/\*zichzelf<sub>i</sub> bewonder.  
 Jan thinks that I him/himself admire  
 'Jan thinks that I admire him.'  
 c. \*Jan<sub>i</sub> denkt dat ik de jongen<sub>i</sub> bewonder.  
 Jan thinks that I the boy admire

Data like (i) have given rise to the formulation of the three conditions in (ii), which have become known as binding conditions A, B and C. We did not define the notion of local domain used in (ii). For the examples in (i), we may provisionally assume that it refers to the minimal clause containing the relevant noun phrase, but there are data that complicate matters; cf. Section N5.2.1.5, sub III, for a more detailed discussion.

- (ii)       • Binding conditions
- a. Anaphors like *zichzelf* ‘himself’ must be bound in their local domain.
  - b. Pronouns like *hem* ‘him’ must be free (= not bound) in their local domain.
  - c. Referential expressions like *Jan* or *de jongen* ‘the boy’ must be free.

Sometimes a distinction is made between A- and A'-binding depending on whether the antecedent is in an argument or a non-argument position. The notion of binding refers to A-binding by default, and the binding conditions in (ii) are thus also intended to restrict A-binding only.

**Blocking:**

The phenomenon that a specific structure is blocked by a structure which is normally more conventional or simpler. Originally, blocking is a morphological notion but it is here extended to syntax; the notion of syntactic blocking has become more familiar since the advent of optimality theory.

**Bound variable:**

See °Accidental coreference

**Bridge verb:**

*Wh*-movement may sometimes extract interrogative argument/adjunct phrases from embedded complement clauses. Whether such extraction is possible or not depends on the verb selecting the complement clause. Verbs that allow such extraction are called bridge verbs. The examples in (ia&b) show that bridge verbs are normally non-factive: factive verbs like *weten* ‘to know’ normally does not license *wh*-extraction. It should be noticed, however, that *wh*-extraction may also occur in relative constructions like (ic), and in such constructions the factive verbs *weten* can be used as a bridge verb. The ability to function as a bridge verb may therefore depend on the type of construction involved.

- (i) a. Wat<sub>i</sub> denk/\*weet je [dat Peter t<sub>i</sub> gekocht heeft]?  
       what think/know you that Peter bought has  
       ‘What do you think that Peter has bought?’
- b. Hoe<sub>i</sub> denk je [dat ik die auto t<sub>i</sub> kan repareren]?  
       how think you that I that car can repair  
       ‘How do you think that I can repair that car?’
- c. Hij liep naar de plaats [waar<sub>i</sub> hij wist [dat de schat t<sub>i</sub> lag]].  
       he walked to the place where he knew that the treasure lay

**Case:**

Many languages express case on the nominal phrases in the clause. A distinction is often made between lexical and structural case. LEXICAL CASE is defined by the fact that it correlates in a one-to-one fashion with a certain meaning or semantic function. In languages like Dutch, use of lexical cases is extremely rare given that it normally expresses semantic functions by means of PPs.

STRUCTURAL CASE depends on a so-called governing lexical element and is prototypically associated with certain thematic roles assigned by verbs: nominative case is normally assigned to agents, accusative case to themes, and dative case to goals, recipients or experiencers. This means that transitive verbs typically govern

accusative case, ditransitive verbs accusative and dative case, and that the so-called NOM-DAT verbs govern dative case. Structural case can, however, also be governed by prepositions: In German, for example, prepositions govern accusative, dative or genitive case. Nominative case is also considered a structural case, but one that is not governed by verbs or prepositions but by the tense feature (past/present) of finite clauses.

Although structural cases are often prototypically assigned to noun phrases with certain thematic roles, the assignment of structural case differs from that of lexical case in that it does not correlate in a one-to-one fashion with such thematic roles. For example, the theme argument of a transitive verb is assigned accusative case in active but nominative case in passive constructions; cf. (i). It is therefore normally assumed that structural case is not determined by semantic function, but assigned to noun phrases in certain structural position (hence its name): accusative case is assigned to noun phrases in direct object position of the clause, whereas nominative case is assigned to noun phrases in subject position. The case frame alternation arises due to the fact that passivization blocks assignment of accusative case by the main verb, so that the theme argument must be assigned nominative by the tense features; in order to make that possible the agent argument must in its turn be suppressed or expressed by means of a *door*-PP.

- (i) a. Jan bezocht Marie/haar gisteren. [active]  
 Jan visited Marie/her<sub>theme+accusative</sub> yesterday
- b. Marie/zij werd gisteren (door Jan) bezocht. [passive]  
 Marie/she<sub>theme+nominative</sub> was yesterday by Jan visited  
 ‘Marie/she was visited yesterday.’

The account of passivization sketched above is built on the premise that noun phrases must be assigned case. Since case is not morphologically expressed in all languages, a distinction is made between morphological and abstract case. Dutch and German differ in that German has morphological but Dutch has abstract case. That Dutch and German make similar case distinctions is clear from the fact that case frame alternations take a similar shape in the two languages. For example, both German and Dutch have two types of passive: the regular passive, in which the accusative (direct) object is promoted to subject, and the so-called semi-passive, in which the dative (indirect) object is promoted to subject; see Section V4.3 for Dutch and, e.g., Drosdowski (1995: Section 2.2.3) and König & Van der Auwera (1994:378-81;471) for German. There is reason for assuming that the two patterns arise due to the fact that the regular passive blocks assignment of accusative case and semi-passive blocks assignment of dative case. But, of course, this account only holds water if we assume that dative and accusative case are also present in Dutch despite the fact that they are not morphologically expressed.

### C-command:

C-command refers to a structural relation between the constituents in a phrase, which is generally defined in structural terms of a tree diagram:  $\alpha$  c-commands  $\beta$  if (i)  $\alpha \neq \beta$ , (ii)  $\alpha$  does not dominate  $\beta$ , and (iii) the node that immediately dominates  $\alpha$  also dominates  $\beta$ . C-command can be partly derived from the selection relations obtaining in the clause. For example, the verb *wachten* in (1a) c-commands the PP

*op zijn vader* as well as all elements contained in it (that is, the preposition *op*, the noun phrase *zijn vader*, the possessive pronoun *zijn* and the noun *vader*), whereas the preposition *op* c-commands the noun phrase *zijn vader* as well as all elements contained in it (the possessive pronoun *zijn* and the noun *vader*). The verb *horen* in (ib) c-commands its infinitival object clause as well as all elements contained in it (the noun phrase *Peter*, the verb phrase *een liedje zingen*, the noun phrase *een liedje*, the article *een*, and the noun *liedje*).

- (i) a. Jan wacht [op zijn vader].
- b. Jan hoorde [Peter een liedje zingen].

If we restrict ourselves to clausal constituents, the c-command relation can often be expressed by means the functional hierarchy in (ii), where the notion  $A > B$  expresses that A c-commands B and everything that is embedded in B. In example (ia), for instance, the subject *Jan* c-commands the PP-object *op zijn vader* as well as everything that is embedded in this PP. In (ib), the subject of the matrix clause, *Jan*, c-commands the infinitival object clause *Peter een liedje zingen* as well as the two arguments of this clause. Furthermore, these arguments of the infinitival clause are also in a c-command relation: the subject *Peter* c-commands the object *een liedje*.

- (ii) **C-command hierarchy:** subject > indirect object-NP > direct object > indirect object-PP > PP-object > adjunct

It must be noted, however, that the hierarchy in (ii) differs from the structurally defined notion of c-command in that it does not take into account that movement may change the c-command relations within a clause.

Many restrictions on syntactic relations can be expressed by appealing to this notion: movement, for example, is only possible if the landing site c-commands the base position of the moved element, and °binding of an anaphor or a pronoun is only possible if the antecedent c-commands it.

**Circumfix:**

A derivational/inflectional affix consisting of two parts, one preceding and one following the input form, e.g., the affix *ge- ... -d* that is used to derive the past/passive participle *gestuurd* ‘sent’ from the stem *stuur-* of the verb *sturen* ‘to send’.

**Clausal adverbial:**

See °adverbial tests.

**Clausal constituent:**

Translation of the Dutch term *zinsdeel*. The notion denotes the constituents in the clause with an independent syntactic function (that is, arguments, complementives and adjuncts) including the °verbal complex.

**Clause splitting:**

See °verb clustering

**Comparison:**

See °degrees of comparison.



**Complement:**

The °arguments of a lexical head H, with the exception of the subject. In generative grammar, complements are generally called INTERNAL ARGUMENTS, whereas the subject is called the EXTERNAL ARGUMENT; an exception is the subject of an °unaccusative verb, which is generally assumed to be an internal argument. Internal arguments of verbs are generally obligatorily present (or at least semantically implied), whereas external arguments can occasionally be suppressed, for instance in the passive construction. The term complement is sometimes also used for °complementives and verbal projections selected by non-main verbs.

**Complementation:**

See °complement.

**Complementive:**

This notion refers to the predicative complement of the verb in copular, resultative or *vinden*-constructions. In (i) some examples are given with adjectival predicates. A complementive may also be a nominal or a (spatial) adpositional phrase, e.g., *Jan is leraar* ‘Jan is a teacher’ and *Jan heeft het boek in de kast gelegd* ‘Jan has put the book in the cupboard’. In prosodically neutral sentences complementives are left-adjacent to the clause-final verb. This is especially clear with PP-complementives, as these differ from other PPs in that they cannot undergo °PP-over-V: \**Jan heeft het boek gelegd in de kast*.

- (i) a. Jan is *erg aardig*.  
       Jan is very kind  
       b. Jan slaat de hond *dood*.  
       Jan hits the dog dead  
       c. Ik vind Jan *erg aardig*.  
       I consider Jan very nice

**Complementizer-trace Filter:**

In the generative literature of the last three decades, it has been argued that there is an asymmetry between subjects on the one hand, and objects and adjuncts on the other, with respect to “long” movement, that is, *wh*-extraction from clauses. Whereas objects and adjuncts can undergo long movement, subjects cannot unless the language has some special proviso that makes this movement possible, such as dropping the complementizer, as in English, or changing the form of the complementizer, like the so-called *que/qui* alternation in French. This is illustrated for English in (i).

- (i) a. Who<sub>i</sub> do you think (\*that) *t<sub>i</sub>* bought the book?  
       b. What<sub>i</sub> do you think (that) John *t<sub>i</sub>* bought?  
       c. When<sub>i</sub> do you think (that) John bought the book *t<sub>i</sub>*?

In traditional generative grammar this was accounted for by the generalization that a complementizer cannot be followed by a subject trace: \*[ ... C *t<sub>i</sub>* ...]. This generalization was originally formulated as the *that*-trace or complementizer-trace filter in Chomsky and Lasnik (1977), but was later derived as one of the empirical consequences of the EMPTY CATEGORY PRINCIPLE (ECP) formulated in Chomsky (1981).

**Conjunction reduction:**

In a coordinated structure, deletion of a phrase within a conjunct under identity with a phrase within the other conjunct. If the deleted phrase belongs to the first conjunct, the deletion operation is referred to as BACKWARD conjunction reduction; if the deleted phrase belongs to the second conjunct, the operation is referred to as FORWARD conjunction reduction; see also °gapping.

- (i) a. [Jan kocht een blauwe \_\_\_] en [Peter kocht een groene auto].  
       Jan bought a blue                      and Peter bought a green car  
       b. [Jan kocht een boek] en [\_\_\_ leende een plaat].  
       Jan bought a book                      and borrowed a record

Backward conjunction reduction is also known as Right Node Raising because early generative grammar derived examples such as (ia) by rightward movement of the putative deleted element simultaneously from the left and the right conjunct; cf. °Across-the-Board movement. This movement analysis is controversial given that it forces us to assume movements that are not independently motivated: in (i), for example, the movement analysis has to assume that the head noun *auto* can be extracted from the complex noun phrase *een blauwe/groene auto*, which is not attested in more uncontroversial cases of leftward movement. The existence of forward conjunction reduction is also controversial; examples such as (ib) can readily be derived by assuming that some lower verbal projections are coordinated: *Jan [[kocht een boek] en [leende een plaat]]*.

**Constituency test:**

Test involving movement of a string of words into the sentence-initial position, that is, the position immediately preceding the finite verb in main clauses. Any string of words that can occupy this position in Dutch is considered a constituent. Satisfying this test is sufficient for assuming constituency, but not necessary given that constituents can be embedded within larger constituents that may function as °islands for extraction. The test provides reasonably reliable results when it comes to the determination of the clausal constituents (the arguments and the adjuncts of the clause). Other tests that are often used are coordination and clefting.

**Contraction verb:**

The stem of a contraction verb ends in a long vowel, and the infinitive is formed by means of an *-n* instead of the regular *-en* ending. Many past participles of the contraction verbs are formed by placing the morpheme *ge-* in front of the infinitival form (which is absent if the infinitive is already prefixed). The present participle of these verbs is formed by adding *-nd* to the stem. The participles of the contraction verbs are special in that they normally cannot be used attributively.

## (i) Contraction verbs

STEM	INFINITIVE	TRANSLATION	PAST PARTICIPLE	PRESENT PARTICIPLE
doe	doen	to do	gedaan	doend
ga	gaan	to go	gegaan	gaand
sta	staan	to stand	gestaan	staand
verga	vergaan	to decay/to be wrecked	vergaan	vergaand
zie	zien	to see	gezien	ziend

**Control:**

The notion of control is used (a) for characterizing an agent that is able to consciously affect the eventuality denoted by the verb, and (b) for the relation between the phonetically empty °PRO-subject of infinitival clauses and a noun phrase (the controller) that determines its reference. In the latter case, the three types of control in (i) are normally distinguished: cf. Williams (1980). The main distinction is that between examples like (ia&b), which involve control by the subject/object of the matrix clause, and examples such as (ic), in which PRO has no controller and receives a generic or arbitrary interpretation. Subject/object control is indicated by means of coindexation and the index *arb(itrary)* is used to indicate that the generic/arbitrary reading is intended.

- (i) a. Jan<sub>i</sub> beloofde Marie<sub>j</sub> [(om) PRO<sub>i/\*j</sub> dat boek te lezen]. [subject control]  
 Jan promised Marie COMP that book to read  
 ‘Jan promised Marie to read that book.’
- b. Jan<sub>i</sub> verzocht Marie<sub>j</sub> [(om) PRO<sub>j/\*i</sub> dat boek te lezen]. [object control]  
 Jan asked Marie COMP that book to read  
 ‘Jan asked Marie to read that book.’
- c. Jan keurt het af [(om) PRO<sub>arb</sub> te vloeken]. [generic interpretation]  
 Jan disapproves it prt. COMP to curse  
 ‘Jan disapproves of cursing.’

A recurring theme in generative grammar is whether subject/object control should be considered a local syntactic dependency, or whether it is determined by semantic and/or pragmatic considerations. The review of this question in Section V4.3 suggests that the answer to this question depends on the type of infinitival clause involved.

**Conversion:**

A morphological process by which some input word becomes part of another word class without the addition of a (phonetically realized) affix. A prototypical example is nominalization of a verb such as *wandelen* ‘to walk’, as in [*Wandelen in het bos*] *is gezond* ‘Walking in the wood is healthy’.

**Cooperative principle:**

A pragmatic principle introduced in Grice (1975) which contributors to an ordinary conversation can be expected to follow: “Make your conversational contribution such as is required, at the stage at which it occurs, by the accepted purpose or direction of the talk exchange in which you are engaged” (Grice 1989:26).

**Core grammar:**

Core grammar refers those aspects of the internalized language system that arise spontaneously in the language learning child by exposure to utterances in the standard language. This notion stands opposed to the periphery of grammar, which refers to those properties of the standard language that are explicitly taught at some later age.

**Coordinate Structure Constraint:**

This constraint prohibits movement of a conjunct out of a coordinated structure: for example, *wh*-movement of the second conjunct in (ia) is impossible, as shown in (ia'). The constraint also prohibits subextraction from one of the conjuncts: for example, subextraction from the second conjunct in (ib) is excluded, as shown in (1b'). An exception to the ban on subextraction is when the movement applies in a so-called °Across-the-Board fashion, that is, simultaneously affects all conjuncts.

- (i) a. Jan heeft [[een artikel] en [een boek ]] gelezen.  
 Jan has an article and a book read  
 a'. \*Wat<sub>i</sub> heeft Jan [[een artikel] en [t<sub>i</sub> ]] gelezen?  
 what has Jan an article and read  
 b. Jan heeft [[een boek van Peter gestolen] en [een CD aan Marie gegeven]].  
 Jan has a book from Peter stolen and a CD to Marie given  
 b'. \*Wat heeft Jan [[een boek van Peter gestolen] en [t<sub>i</sub> aan Marie gegeven]]?  
 what has Jan a book from Peter stolen and to Marie given

**Dative case:**

The °case prototypically assigned to a goal, a recipient or an experiencer argument of the main verb in active clauses. Noun phrases marked with dative case are often referred to as indirect objects. German has a set of prepositions that assign dative case to their nominal complement; this may also be the case in Dutch but this is hard to establish due to the fact that dative case is not morphologically distinct from accusative case in Dutch. There is reason for assuming that certain adjectives are able to assign dative case in Dutch; cf. A2.2.

**Degrees of comparison:**

The degrees of comparison are given in (i). Instead of laborious terms like *comparative in relation to a higher degree*, we will use the shorter terms like *majorative degree*. In (i), these terms are given in small caps. See A4 for more discussion.

- (i) a. POSITIVE degree *groot* 'big'  
 b. Comparison in relation to a higher degree:  
 (i) comparative: MAJORATIVE degree *groter* 'bigger'  
 (ii) superlative: MAXIMATIVE degree *grootst* 'biggest'  
 c. Comparison in relation to the same degree:  
 EQUATIVE degree *even groot* 'as big'  
 d. Comparison in relation to a lower degree:  
 (i) comparative: MINORATIVE degree *minder groot* 'less big'  
 (ii) superlative: MINIMATIVE degree *minst groot* 'least big'

**D-linking:**

D-linking is a pragmatic notion that stands for Discourse-linking and refers to the ability of certain *wh*-phrases to refer to referents pre-established in the domain of discourse (domain D). A *wh*-phrase like *welke auto* 'which car' is always D-linked: a question containing this *wh*-phrase requires an answer that refers to some entity that is part of domain D. A *wh*-phrase like *wat* 'what' can but need not be D-linked: a question containing this *wh*-phrase may but need not require an answer that refers

to some entity that is part of domain D. A *wh*-phrase like *wat voor een auto* ‘what kind of car’ is never D-linked: a question containing this *wh*-phrase cannot be answered by referring to an entity that is part of domain D. The distinction between D-linked and non-D-linked *wh*-phrases is relevant for the description of several syntactic phenomena; see Pesetsky (1987). In this work we will also use this notion for non-interrogative phrases.

**DO-subject:**

The subject of a passive or an °unaccusative verb. The term DO-subject expresses that the subjects of unaccusative and passive verbs have various properties in common with the direct objects of transitive verbs. Other terms referring to the same notion are DERIVED SUBJECT and LOGICAL OBJECT.

**Dyadic verb:**

See °adicity.

**Downtoner:**

See °Intensifier.

**Easy-to-please construction:**

A construction named after the English reference sentence *John is easy to please*. The various types of this construction that can be found in Dutch as well as a proposal for analysis can be found in Section A6.5.4.1.

**Echo-question:**

Echo-questions are utterances that repeat an earlier utterance in discourse while replacing a word or a string of words by an accented *wh*-word. Echo-questions are not true questions but are used if the speaker did not understand a certain part of the earlier utterance, to express surprise etc. For example, speaker B can use (ib) if he did not properly hear the word *Rolex*, if he does not know what a Rolex is, or to express surprise about the fact that Jan has bought such a luxury item.

- |     |    |  |             |
|-----|----|--|-------------|
| (i) | a. | Jan heeft een Rolex gekocht<br>Jan has a Rolex bought<br>‘Jan has bought a Rolex.’ | [speaker A] |
|     | b. | Jan heeft een WAT gekocht?<br>Jan has a what bought                                | [speaker B] |

**Eventuality:**

Cover term used to refer to the denotation of verbs that unifies notions like state, processes, events, etc. A more or less equivalent term is state-of-affairs.

**Expletive:**

The element *er* in existential or presentational constructions like (ia&b). Example (ic) shows that, unlike the English expletive *there*, expletive *er* can also occur in transitive clauses, provided that the direct object is non-specific indefinite. The fact that (ic) is marked with a definite object may be part of a more general phenomenon: expletive *er* is often disfavored (though acceptable) in the presence of some presuppositional element. This is illustrated in (ic’) by means of the locational pro-form *daar* ‘there’. See Section 8.1.4 for more discussion.

- (i) a. dat er een probleem met de verwarming is.  
 that there a problem with the heating is  
 ‘that there is a problem with the heating.’  
 b. dat er een man op straat loopt.  
 that there a man in the street walks  
 ‘that there is someone walking in the street.’  
 c. dat er iemand een<sup>??</sup>het lied zingt.  
 that there someone a/the song sings  
 c’. dat (<sup>??</sup>er) daar iemand een lied zingt.  
 that there there someone a song sings

The notion expletive is sometimes also used to refer the personal pronoun *het* in constructions like *Het regent*, for which it has been claimed that the pronoun does not function as a “true” argument of the verb in the sense that it has not been assigned a °thematic role.

**Extrapolation:**

A movement operation assumed to place a clause to the right of the verbs in clause-final position. Under the traditional OV-analysis of Dutch, complement clauses are base-generated to the left of the main verb, as in (ib), and obligatorily moved to the right of the verb. Extrapolation of PPs is called °PP-over-V. Extrapolation of noun phrases and APs is not possible in Dutch.

- (i) a. dat Jan [dat hij ziek is] denkt ⇒  
 that Jan that he ill is thinks  
 b. dat Jan <sub>i</sub> denkt [dat hij ziek is]<sub>i</sub>

Since Kayne (1994) there has been an ongoing debate concerning whether (ib) is derived from (ia) by means of extrapolation or whether the complement is base-generated to the right of V; cf. Baltin (2006) and Broekhuis (2008:ch.2) for a review of a number of the currently available proposals. In this work, we will use the notion of extrapolation as a purely descriptive term in order to refer to the placement of the clause to the right of the verb.

**Floating quantifier:**

Floating quantifiers are quantifiers which are associated with noun phrases occurring elsewhere in the sentence, but with which they do not form a syntactic constituent. An example is *allen* in (i), which is associated with the subject of the clause *die jongens*.

- (i) Die jongens zijn allen vertrokken.  
 those boys are all left  
 ‘Those boys have all left.’

The notion of a floating quantifier reveals a particular transformational outlook on the phenomenon: it is often assumed that the quantifier and the noun phrase it quantifies form an underlying constituent which is split up in the course of the syntactic derivation via either movement of the quantifier or movement of the remnant noun phrase; cf. Kayne (1975) and Sportiche (1988). There are, however, also analyses according to which floating quantifiers are independently generated

adjuncts; cf. Doetjes (1997). We refer the reader to Bobaljik (2003) for a discussion of the various approaches. In this work, the term floating quantifier is used as a pre-theoretical notion.

**Focus:**

The notion of focus is used in several different ways that should be kept strictly apart; see De Swart and De Hoop (2000) and Kiss (2002) for a more extensive discussion of this notion.

I. If we are concerned with the information structure of the clause, focus refers to the “new” information in the clause. As such it is opposed to presupposition, which refers to the “old” information in the clause.

II. Focus is also used for certain elements in the clause that are phonetically emphasized by means of accent. Often, a distinction is made between emphatic, contrastive and restrictive focus. EMPHATIC focus simply highlights one of the constituents in the clause, as in (ia). CONTRASTIVE focus is normally used when one or more specific referents are part of the domain of discourse to which the proposition does not apply, and can also be used to deny a certain presupposition on the part of the hearer, as in (ib). RESTRICTIVE focus implies that the proposition in question is not true of any other referents: a specific, restricted set is selected and a proposition is said to hold for this set only. It is often used for restrictive adverbial phrases like *van Jan* in (ic): assigning focus to this phrase suggests that the other relevant persons in the discourse did not yet hand in the assignment.

- (i) a. Ik heb hem een BOEK gegeven.  
I have him a book given  
'I have given him a BOOK.'
- b. Nee, ik heb hem een BOEK gegeven (en geen PLAAT).  
no, I have him a book given and not.a record  
'No, I gave him a BOOK (not a RECORD).'
- c. Van JAN heb ik de opdracht al ontvangen.  
from Jan have I the assignment already received  
'From JAN, I have already received the assignment.'

**Freezing:**

The phenomenon that extraction from certain moved constituents is not possible. For example, if a prepositional complement occupies its “unmarked” position immediately to the left of the clause-final verb(s), °R-extraction is possible, as shown by (ia). However, if it occupies a position more to the left, R-extraction is excluded, as is shown by (ib'). In the primed examples the stranded preposition and its moved complement are in italics. For a detailed discussion of Freezing, we refer the reader to Corver (2006)

- (i) a. dat Jan al tijden op dat boek wacht.  
that Jan already ages for that book waits  
'that Jan has already been waiting for that book for ages.'
- a'. het boek *waar* Jan al tijden *op* wacht  
the book where Jan already ages for waits  
'the book that Jan has already been waiting for ages'



- b. dat Jan op dat boek al tijden wacht.  
 b'. \*het boek *waar* Jan *op* al tijden wacht

**Gapping:**

An operation applying to coordinated clauses, which involves deletion of elements in the second conjunct under identity with elements in the first conjunct. Gapping (in contrast to °conjunction reduction) must minimally affect the finite verb of the second conjunct, as in (ia). If the clause contains an auxiliary, either the auxiliary alone, as in (ib), or the auxiliary and the main verb can be deleted, as in (ic). In addition to the verb(s), Gapping can also delete other constituents of the second conjunct, as in (id). The second conjunct must contain at least two pronounced constituents, which are contrastively stressed.

- (i) a. Jan schrijft een roman en Peter [<sub>V</sub> ∅] een toneelstuk.  
 Jan reads a novel and Peter a play  
 b. Jan heeft een roman geschreven en Peter [<sub>AUX</sub> ∅] een toneelstuk opgevoerd.  
 Jan has a novel written and Peter a play performed  
 c. Jan heeft een roman geschreven en Peter [<sub>AUX</sub> ∅] een toneelstuk [<sub>V</sub> ∅].  
 Jan has a novel written and Peter a play  
 d. Jan heeft Marie naar huis gebracht en Piet [<sub>AUX</sub> ∅] Karel [<sub>PP</sub> ∅] [<sub>V</sub> ∅].  
 Jan has Marie to home brought and Piet Karel

**Govern(ment):**

We use this notion in its traditional sense of referring to a specific syntactic relation in which a lexical item requires a special morphological form of its °complement. For example, the German verb *lesen* ‘to read’ governs a noun phrase with accusative case, whereas the German verb *geben* ‘to give’ governs two noun phrases, one with accusative case and one with dative case. Similarly, we may say of a perfect auxiliary that it governs a participial verb, whereas an aspectual verb like *gaan* governs a bare infinitival verb.

- (i) a. Jan heeft dat boek gelezen/\*lezen  
 Jan has that book read<sub>part</sub>/read<sub>inf</sub>  
 ‘Jan has read that book.’  
 b. Jan gaat dat boek lezen/\*gelezen.  
 Jan goes that book read<sub>inf</sub>/read<sub>part</sub>  
 ‘Jan is going to read that book.’

**Head:**

An element that projects, which is to say that is the core of a projection. There are two notions of head: (i) lexical heads like V, N, A and P which are predicative in nature in the sense that they take °arguments, and (ii) functional heads like T(ense) and D(et) which are not predicative and add more peripheral functional information. See Section V9.1 for a more extensive introduction of these notions.

**Head-final Filter on attributive adjectives:**

The Filter in (i) requires that the adjective carrying the attributive *-e/-∅* ending be adjacent to the noun it modifies. The filter is formulated such that it allows recursive patterns such as [<sub>NP</sub> een [mooie [grote [Amerikaanse [N auto]]]]] ‘a

beautiful big American car’; see Section 3.5.3.1.2 for a more extensive discussion of this filter.

- (i) **Head-final Filter on attributive adjectives:** \* $[_{NP} \dots [_{AP} \text{ ADJ XP}] N^\#]$ , where XP is phonetically non-null and  $N^\#$  is a bare head noun or a noun preceded by an adjective phrase:  $[(AP) N]$ .

**Implicature:**

Information that is not part of the meaning expressed by the form of a sentence but can be deduced from it on the basis of specific pragmatic rules such as the °maxims derived from the °cooperative principle: “Make your conversational contribution such as is required, at the stage at which it occurs, by the accepted purpose or direction of the talk exchange in which you are engaged”; cf. (Grice 1989:26).

**Information structure:**

The structure of sentences (and larger units) viewed as an information unit, in as far as it can be described in terms of information focus versus presupposition (discourse-new versus discourse old information), topic versus comment, contrastive focus versus background, etc.

**Initial coordination:**

Initial coordination involves coordination where each conjunct is preceded by one part of a discontinuous coordinator like *of ...of ...* ‘either ... or ...’ and *zowel ... als ...* ‘both ... and ...’.

- (i) a. *of de oude mannen of de oude vrouwen*  
 either the old men or the old women  
 b. *zowel de oude mannen als de oude vrouwen*  
 both the old men and the old women

**Implied subject:**

See °PRO.

**Individual-level predicate:**

See Stage/Individual-level predicate.

**Intensifier:**

An adverbial modifier of a scalar adjective that specifies the degree to which the property denoted by the adjective holds. There are three types of intensifiers: AMPLIFIERS, which scale upwards from a tacitly assumed norm, DOWNTONERS, which scale downwards from the assumed norm, and NEUTRAL INTENSIFIERS, which are neutral in this respect; see Section A3.1.2.3 for a more detailed discussion.

**Irrealis/realis:**

Terms which are used to characterize the interpretation of clauses in semantics by considering the status of the eventualities expressed by them in the active tense domain: the realis and irrealis interpretations differ in that only the former expresses that the eventuality is realized in the actualized part of the relevant tense domain. Note that it is irrelevant for an irrealis interpretation whether or not the eventuality

will be realized in the non-actualized part of the relevant tense domain. The term irrealis verb is used for verbs that select an irrealis complement clause.

**Island for extraction:**

An island for extraction is a constituent out of which extraction cannot take place. A distinction can be made between *strong* and *weak* islands. Strong islands are constituents out of which extraction is blocked categorically, whereas weak islands are constituents out of which only specific elements (especially adjunct phrases) cannot be extracted.

**Infinitivus-Pro-Participio:**

Example (ia) shows that the perfect auxiliaries *hebben* and *zijn* are normally construed with a verb in the form of a past participle. This is not the case, however, if these auxiliaries govern a verbal sequence of two or more verbs. The modal verb in (ib), for example, is not realized as a past participle but as an infinitive. This phenomenon is referred to as the Infinitivus-Pro-Participio (or IPP) effect.

- (i) a. Jan heeft het boek gelezen/\*lezen.  
 Jan has the book read<sub>part</sub>/read<sub>inf</sub>  
 b. Jan heeft het boek willen/\*gewild lezen.  
 Jan has the book want/wanted read

**Lambda conversion:**

Formal logic term from the domain of lambda abstraction. Lambda abstraction applies to logical formulas such as  $P(x)$  in order to create predicates:  $\lambda xP(x)$  is a one-place predicate. Lambda conversion applies lambda expressions to arguments: the variable bound by the lambda operator is replaced with an argument, thus creating propositions from predicates: when we apply the predicate  $\lambda xP(x)$  to argument  $j$  we form the proposition  $P(j)$ . Example:  $\lambda x\text{LAUGH}(x)$  applied to *Jan* results in  $\text{LAUGH}(\text{Jan})$ .

**Left dislocation:**

A construction akin to topicalization, but which does not involve movement of the dislocated element. The dislocated element is probably external to the sentence, which is clear from the fact that it is associated with a resumptive element in sentence-initial position immediately preceding the finite verb in second position of the main clause; cf. °Verb second. If the left-dislocated element corresponds to a nominal argument of the sentence, as in (ia), the resumptive element is the demonstrative pronoun *die/dat*. If the left-dislocated element corresponds to the object of a preposition, the resumptive element is an °R-pronoun or a complete PP, as in (ib) and (ic), respectively. Various other resumptive elements are used if the left-dislocated element is not a nominal argument of the verb; this is illustrated in (id&e) for left-dislocated elements that correspond to an adverbial phrase of time and place; See the collection of papers in Anagnostopoulou et al. (1997) and Alexiadou (2006) for a detailed discussion.

- (i) a. Dat boek, *dat* heb ik gisteren gelezen.  
that book that have I yesterday read
- b. Die jongen, *daar* heb ik gisteren *over* gesproken.  
that boy there have I yesterday about spoken
- c. Die jongen, *over hem* heb ik gisteren gesproken.  
that boy about him have I yesterday spoken
- d. Morgen, *dan* ga ik naar Groningen.  
tomorrow then go I to Groningen  
'Tomorrow, I'll go to Groningen then.'
- e. Amsterdam, *daar* ben ik geboren.'  
Amsterdam there was I born  
'Amsterdam, I was born there.'

### Lexical integrity constraint:

Constraint according to which no syntactic process may affect a subpart of a word. For example, *wh*-movement may not apply to the first part of the compound *CD-speler* in (ia); cf. Di Sciullo & Williams (1987:ch.3).

- (i) a. Jan kocht [een [<sub>N</sub> CD-speler]]  
Jan bought a CD player
- b. Wat<sub>i</sub> kocht Jan [een [<sub>N</sub> t<sub>i</sub> speler]]?  
what bought Jan a player

### Litotes:

The use of negation to emphatically express the opposite of what is expressed by the negated element: cf. *Dat boek is niet slecht* with the literal meaning "that book is not bad" versus the litotes reading "that book is very good"

### Logical SUBJECT (vs. grammatical subject):

The constituent of which some other constituent in the clause is predicated. This notion of logical SUBJECT coincides with the notion of external °argument in generative grammar and is thus based on the °thematic relations within the clause. It differs from the traditional notion of (grammatical) subject that is used to refer to the nominative argument in the clause. In (ia), for example, the adjective *leeg* 'empty' is predicated of the noun phrase *de fles* 'the bottle', which therefore functions as the logical SUBJECT of *leeg*. Although this is not uncontroversial, we will assume in this work that the predicate and its SUBJECT form a SMALL CLAUSE, that is, a complex constituent headed by the predicative element; cf. Stowell (1981/1983). More examples are given in (ib&c), where the noun phrases *Peter* and *de boeken* function as the SUBJECT of, respectively, a nominal and a prepositional predicate. The notion of SUBJECT is discussed more extensively in Section A6.1.

- (i) a. Jan gooide [<sub>SC</sub> de fles leeg].  
Jan threw the bottle empty
- b. Jan noemde [<sub>SC</sub> Peter een leugenaar].  
Jan called Peter a liar
- c. Jan zette [<sub>SC</sub> de boeken in de kast].  
Jan put the books in the cupboard

### Maxim

Notion from pragmatics related to Grice's (1975/1989) °cooperative principle according to which contributors to ordinary conversation are expected to optimize their conversational contribution to the talk exchange they are engaged in. Speakers are expected to follow the following rules (maxims):

- (i) a. **Maxim of Quantity:** make your contribution as informative as is required; do not make your contribution more informative than required.
- b. **Maxim of Quality:** do not say what you believe to be false; do not say that for which you lack adequate evidence.
- c. **Maxim of Relation:** be relevant.
- d. **Maxim of Manner:** avoid obscurity of expression; avoid ambiguity; be brief; be orderly.

### Material implication:

A term from propositional logic for the relation IF X THEN Y. This relation expresses that if X is true Y is true as well, and that if Y is false X is false too. Note that it does not express that if X is false Y is false; if X is false Y can either be true or false.

### Matrix:

A MATRIX CLAUSE is a clause in which some other clause or smaller verbal projection is embedded. By extension, we will use the notion of MATRIX VERB for verbs heading a matrix clause. We will further restrict the notions by requiring that the embedded clause/verbal projection is selected by the matrix verb: matrix verbs that are main verbs take the embedded clause as an argument, and matrix verbs that are non-main verbs impose restrictions on the form of the dependent verbal projection. For example, perfect auxiliaries normally take a verbal projection headed by a participle, whereas aspectual verbs take verbal projections headed by an infinitive.

### Middle field:

The middle field of the clause is defined as that part of the clause bounded to the right by the verbs in clause-final position (if present), and to the left by the complementizer in an embedded clause or the finite verb in second position of a main clause. The middle field of the examples in (i) is given in italics. In Section V9, it is argued that the position of the complementizer and the finite verb in second position are actually the same, the so-called C(omplementizer)-position: in main clauses, the finite verb is moved from clause-final position into this C-position, whereas in embedded clauses this movement does not take place, and the complementizer can be used to fill it. In the following abstract representation of the clause, the middle field can therefore be defined as the part between C and V: [CP e C ..... V .....].

- (i) a. Gisteren heeft *Jan met plezier dat boek* gelezen.  
yesterday has Jan with pleasure that book read
- b. Ik denk [dat *Jan met plezier dat boek* gelezen heeft].  
I think that Jan with pleasure that book read has

It is important to realize that the middle field of a clause is not a constituent, but simply refers to a set of positions within the clause. This set of positions includes the base positions of the nominal arguments of the verb within VP (but not the verb itself), as well as a variety of positions external to VP such as the positions of the adverbial phrases and positions that can act as a landing site for, e.g., °scrambling.

**Modifier:**

Modification is the syntactic relation between two elements by which, e.g., the denotation of the modified phrase is restricted. Modification is typically obtained by means of adverbial phrases, attributive adjectives, etc. The modifying phrase is referred to as a MODIFIER.

**Modus tollens:**

A valid argumentation form and a rule of inference also known as “denying the consequent”: from the °material implication IF X THEN Y and the denial of Y, we may conclude that X is not true either.

**Monadic verb:**

See °adicity.

**Monoclausal behavior**

This notion refers to two typical properties exhibited by structures containing a °verbal complex: °verb clustering and the °Infinitivus-Pro-Participio effect.

**Movement:**

The notion of movement is used to express that a given constituent is found in some other position than one might expect on the basis of its properties, e.g., syntactic function. For example, despite the fact that direct objects are normally placed before the verbs in clause-final position, they typically occur in clause-initial position if they are *wh*-phrases such as *welk boek* ‘which book’ in (ib). The °trace  $t_i$  in (ib) indicates that the preposed *wh*-phrase functions as the direct object of the clause.

- (i) a. Jan heeft gisteren *De zondvloed* van Jeroen Brouwers gelezen.  
 Jan has yesterday *De zondvloed* by Jeroen Brouwers read  
 ‘Jan read *De zondvloed* by Jeroen Brouwers yesterday.’
- b. Welk boek<sub>*k*</sub> heeft Jan gisteren  $t_i$  gelezen?  
 which book has Jan yesterday read  
 ‘Which book did Jan read yesterday?’

There are two main types of movement: A-movement and A'-movement. The first type involves movement of a phrase from an °argument position into another argument position, as in passive and °unaccusative constructions. The second type involves movement of a phrase into a non-argument position; the prototypical case is the clause-initial position targeted by *wh*-movement. For more discussion, see °argument position.

Although work in generative grammar suggests that there are strong reasons to take the notion of movement literally, it is also conceivable to construe it in a metaphorical sense. We leave it to the reader to choose between the two options, and will not review the more theoretical debate concerning this notion. See the

introduction to Cheng & Corver (2000), as well as the papers collected therein, for relevant theoretical discussion.

**Nominative case:**

The °case prototypically assigned to the agent argument of (in-)transitive verbs in finite clauses. In regular passive and °unaccusative constructions, nominative case is assigned to the theme argument of a main verb or to the SUBJECT of a °complementive. In semi-passive constructions, nominative case is assigned to the recipient/goal argument of the main verb. A noun phrase marked with nominative case is often referred to as subject.

**Negative concord:**

The multiple occurrence of negative elements in a clause with a single negative interpretation as their combined effect; there is no canceling out of negation, unlike in cases of double negation.

**Negative polarity:**

Negative polarity items are constituents that cannot occur in all environments, but require some other element, like negation, in their environment to license them. Typical examples are the *ook maar*-phrases in (i): this phrase is licensed in (ia) by the negative noun phrase *niemand*, but blocked in (ib) due to the absence of such a negative constituent. Example (ic) shows that negative polarity items can also occur in, e.g., hypothetical contexts.

- (i) a. Niemand heeft ook maar iets gezegd.  
       nobody has OOK MAAR something said  
       ‘Nobody has said anything at all.’
- b. \*Jan heeft ook maar iets gezegd.  
       Jan has OOK MAAR something said
- c. Als er ook maar iets tegenzit, raakt hij in paniek.  
       if there OOK MAAR something go-against become he in panic  
       ‘If anything at all goes wrong, he panics.’

**NP-movement:**

A movement operation that places an argument from a case-less position into a case-marked position. This operation takes place in, for instance, Passive and Subject Raising Constructions. In Passives, the passive participle is not able to assign accusative case to the theme-argument, which must therefore be moved into the regular subject position. Schematically, this can be represented as in (ia), where NP<sub>i</sub> is the underlying object in regular subject position and t<sub>i</sub> is its °trace in the case-less direct object position. In subject raising constructions, it is assumed that the subject of the infinitival clause cannot be assigned case and is therefore raised to the subject position of the higher clause, where it can be assigned nominative case.

- (i) a. [NP<sub>i</sub> Infl aux [VP V<sub>passive</sub> participle t<sub>i</sub>]] [passive]
- b. [NP<sub>i</sub> Infl V [clause t<sub>i</sub> ... te V<sub>infinitive</sub> ...]] [subject raising]

Dutch differs from English in that NP-movement is often optional. In the more theoretical discussions we will often ignore this optionality, and only discuss it when it is needed to account for certain word order phenomena.



**Objective case:**

Since Dutch does not have a morphological distinction between accusative and dative case, this notion is sometimes used when the syntactic distinction between the two cases does not play a role.

**Omission test:**

A test used to determine what the head of a certain construction is. The element that cannot be omitted is the head of the construction. Given that the object *mooie boeken* in *Jan heeft mooie boeken* ‘Jan has nice books’ can be reduced to the noun *boeken*, it follows that this noun is the head of the complex NP.

**Operator:**

A term borrowed from predicate calculus, where it refers to those elements that combine with a formula  $\phi$  in order to bind a variable, thereby creating a new formula  $OP\phi$ . Examples of such operators are the existential operator  $\exists x$ , the universal operator  $\forall x$ , and the negative operator  $\neg$ . In generative syntax, this notion is extended to expressions from natural languages such as *iemand* ‘someone’, *iedereen* ‘everyone’, *niet* ‘not’, and *wh*-phrases such as *wie* ‘who’ and *wat* ‘what’.

**Parasitic gap:**

An empty element in the sentence that is assumed to be licensed by the antecedent of another empty element in the sentence. In (ia), the empty object position in the infinitival clause headed by the verb *lezen* ‘to read’ is assumed to be licensed by the antecedent of the trace that occupies the object position of the verb *opbergen* ‘to file’. The empty position within the adjunct clause *zonder te lezen* cannot be the trace of the moved *wh*-phrase *wat* ‘what’ since adjuncts are °islands for extraction. The structure of (ia) is therefore as indicated in (ib), in which *t* stands for the trace of *wat*, and PG is the parasitic gap.

- (i) a. Wat heb je zonder te lezen opgeborgen?  
       what have you without to read prt.-filed  
       ‘What did you file without reading?’  
    b. Wat heb je [zonder PG te lezen] *t* opgeborgen.

It is often assumed that PG is actually a trace of a phonetically empty operator OP that is moved into the initial position of the adjunct clause. In Dutch, parasitic gaps are licensed not only by *wh*-movement, but also by scrambling. This is shown in (iia), which is assumed to have the structure in (iib), where *t* is the trace of the moved direct object *dat boek*, and PG stands for the parasitic gap licensed by scrambling.

- (ii) a. Jan heeft dat boek zonder te lezen opgeborgen.  
        Jan has that book without to read prt.-filed  
        b. Jan heeft dat boek [zonder PG te lezen] *t* opgeborgen.

**Particle:**

The notion particle is difficult to define as it is often used to refer to elements with a specific syntactic function but which do not fit in any obvious way in the commonly distinguished part of speech. We distinguish between modal particles, which are

normally related to the speaker's attitude toward the propositional content of the utterance, focus particles, which are used for emphasizing a specific element in the clause and verbal particles, which form a meaning unit with the verb.

- (i) a. Je kwam morgen toch? [modal particle]  
 you came tomorrow PRT  
 'Am I correct in assuming that you will come tomorrow?'  
 b. Zelfs Peter heb ik gezien? [focus particle]  
 even Peter have I seen  
 'I have even seen Peter.'  
 c. Ik heb de kamer opgeruimd. [verbal particle]  
 I have the room prt-cleared  
 'I have tidied up the room.'

Modal particles are like adverbial phrases in that they clearly have an °adjunct status. Focus particles are more difficult to characterize in that they can function as a modifier, as in (ib), but can sometimes also occur independently. Verbal particles are often analyzed as °complementives; cf. Section V2.2.1.

### Partitive genitive:

Term that refers to adjectives ending in *-s*. Such adjectives are found in the so-called genitive partitive constructions (*iets moois* 'something beautiful') discussed in Section A7.

### Passive:

Dutch has two types of passive. The first type is the so-called regular passive illustrated in (ib) and (iib), which requires the presence of the auxiliary *worden* 'to be' or *zijn* 'to be' (lit.: to have been) and promotes the direct object to subject. The second type is the so-called semi- or *krijgen*-passive, illustrated in (iic), which requires the presence of the auxiliary *krijgen* 'to get' and promotes the indirect object to subject.

- (i) a. Jan verkocht de boeken.  
 Jan sold the books  
 b. De boeken werden verkocht.  
 the books were sold  
 (ii) a. Jan bood Marie de boeken aan.  
 Jan offered Marie the books prt.  
 b. De boeken werden Marie aangeboden.  
 the books were Marie prt.-offered  
 c. Marie kreeg the boeken aangeboden.  
 Marie got the books prt.-offered

The *krijgen*-passive is often considered idiomatic but it can be argued that it is in fact a productive process. The main reason for adopting the first position is that a prototypical double object verb like *geven* 'to give' does not allow it; cf. (iiiib). This may be due, however, to the fact that *geven* is semantically light in the sense that it does not have a manner component and merely indicates that some object is

transferred; it is conceivable that this lightness make it possible to elide the participle in (iiib'), which would result in the fully acceptable sentence in (iiic).

- (iii) a. Jan gaf Marie de boeken aan.  
 Jan gave Marie the books prt.  
 b. \*Marie kreeg the boeken gegeven.  
 Marie got the books given  
 c. Marie kreeg the boeken.  
 Marie got the books

### Periphery of grammar:

See °core grammar

### Pied piping:

In interrogative clauses the clause-initial position must be occupied by a *wh*-word, as in (ia). Occasionally, however, *wh*-movement may or must involve a phrase larger than a *wh*-word. In (ib), for example, the preposition must be moved along with the *wh*-element *wie* 'who'. This phenomenon is called pied piping: the *wh*-element *wie* pied pipes the preposition *op*. Pied Piping is also found in other movement types.

- (i) a. Wie heb je gezien?  
 who have you seen  
 'Who did you see?'  
 b. Op wie heb je gewacht?  
 for whom have you waited  
 'Who were you waiting for?'

The term pied piping stands in opposition to term stranding, which refers to cases in which the *wh*-word is extracted from a larger clausal constituent (as in the English translation of (ib), in which *wh*-movement strands the preposition *for*). Pied piping and stranding are often in complementary distribution, but this is not a hard and fast rule; the examples in (ii) show, for instance, that interrogative *wat voor*-phrases allow both options.

- (ii) a. [Wat voor een boeken]<sub>i</sub> heeft Peter <sub>t<sub>i</sub></sub> gekocht? [pied piping]  
 what for a books has Peter bought  
 'What kind of books has Peter bought?'  
 b. Wat<sub>i</sub> heeft Peter [<sub>t<sub>i</sub></sub> voor een boeken] gekocht? [stranding]  
 what has Peter for a books bought  
 'What kind of books has Peter bought?'

### PP-over-V:

Many adpositional phrases can occur both in a position preceding and in a position following the verb(s) in clause-final position. Some examples are given in (i). In traditional generative grammar, it is assumed that the order in (ia) is the base order; (ib) involves PP-over-V of the adverbial adjunct of place *op het station* 'at the station'; example (ic) involves PP-over-V of the PP-complement of the main verb, *op zijn vader* 'for his father'; in example (id) both PPs follow the main verb.

Observe that the PPs occur in inverted order in (ia) and (id): PP-over-V of more than one PP results in a mirroring of the original order.

- (i) a. Jan heeft op het station op zijn vader gewacht.  
 Jan has at the station for his father waited  
 ‘Jan has waited for his father at the station.’  
 b. Jan heeft op zijn vader gewacht op het station.  
 c. Jan heeft op het station gewacht op zijn vader.  
 d. Jan heeft gewacht op zijn vader op het station.

PP-over-V seems to be related to the information structure of the clause. In Dutch the presence of expletive *er* signals that the clause does not contain a constituent expressing a presupposition. Given the fact that the expletive is optional in (iia), we must conclude that the PP *in het stadion* can be interpreted either as part of the focus of the clause or as a presupposition. However, the obligatory presence of the expletive in (iib) indicates that the postverbal PP must be part of the focus of the clause (See also Guéron 1980, Koster 1978, Scherpenisse 1985).

- (ii) a. dat (er) in het stadion gevoetbald wordt.  
 that there in the stadium played-soccer is  
 ‘that People are playing soccer in the stadium.’  
 b. dat \*(er) gevoetbald wordt in het stadion.

The traditional assumption that PP-over-V involves extraposition of the PP (Koster 1973/1974) has recently been challenged, and many alternative proposals are available at this moment; see, e.g., Kayne (1994), Koster (2000), Barbiers (1995), Kaan (1997), Bianchi (1999), De Vries (2002), and Broekhuis (2008) for relevant discussion. Since it is descriptively simpler, we adopt the traditional view in the main text, but it should be kept in mind that this is not the generally accepted view at the present moment.

**Preposition stranding:**

See °R-extraction.

**Presupposition:**

See °focus.

**PRO:**

A phonetically unrealized pronominal noun phrase that may act as the subject of, e.g., an infinitival clause. PRO may be °controlled by (= construed as coreferential with) some noun phrase in the matrix clause, as in (ia), or be interpreted as having arbitrary reference, as in (ib).

- (i) a. Jan<sub>i</sub> probeert [PRO<sub>i</sub> de gootsteen te repareren].  
 Jan tries the sink to repair  
 ‘Jan tries to fix the sink.’  
 b. Het is leuk [PRO<sub>arb</sub> Marie te bezoeken].  
 it is nice Marie to visit  
 ‘It is nice to visit Marie.’

**Projection:**

Each lexical head L is assumed to form a so-called lexical projection (= a larger structure) LP by combining with its arguments and (optional) modifiers. Generally, it is assumed that a lexical projection is hierarchically structured: first, L combines with its complement(s) and after that it combines with its subject and modifiers. Evidence for this comes, e.g., from °binding: a subject can bind an object but not vice versa.

In current generative grammar it is commonly assumed that functional heads (like complementizers, numerals or determiners) project a so-called functional projection FP by combining with some lexical projection LP or some other functional projection. For example, the noun phrase *de drie kleine kinderen* ‘the three little children’ is assumed to have the structure in (i): first, the lexical N *kinderen* ‘children’ combines with its attributive modifier *kleine* to form the lexical projection NP; after that, the numeral *drie* ‘three’ forms the functional projection NumP by combining with the NP; finally, the determiner *de* ‘the’ combines with the NumP, and forms the functional projection DP.

- (i)            [DP de [NumP drie [NP kleine kinderen]]]  
                  the        three    little    children

**Pronominal PP:**

See °R-pronominalization

**Psych(ological) verb:**

Verb referring to the mental state of an [+ANIMATE] argument. Various types can be distinguished on the basis of the status of the argument. It can be an external argument, as in *Jan vreest zijn vader* ‘Jan is afraid of his father’ but it can also be an internal argument, e.g. *Dat boek bevalt hem* ‘That book pleases him’ and *De muziek ergert hem* ‘The music annoys him’; cf. Belletti & Rizzi (1988).

**Quantitative er:**

Indefinite (but not definite) noun phrases containing a cardinal numeral or a weak quantifier may co-occur with so-called quantitative *er*; cf. (ia&b). A noun phrase associated with quantitative *er* is characterized as containing an interpretative gap [*e*]. The descriptive content of this gap must be recoverable from the discourse or the extra-linguistic context. Example (ic) shows that the empty noun must be [+COUNT]; when it is [-COUNT], quantitative *er* cannot be used. Quantitative *er* is discussed in more detail in Section N6.3.

- (i) a. Jan heeft twee (mooie) boeken en Piet heeft er [drie [*e*]].        [indefinite]  
       Jan has two beautiful books and Piet has ER three  
    a'. \*Jan heeft de twee boeken en Piet heeft er [de drie [*e*]].        [definite]  
       Jan has the two books and Piet has ER the three  
    b. Jan heeft weinig boeken maar Marie heeft er [veel [*e*]].  
       Jan has few books but Marie has ER many  
    c. \*Jan heeft veel wijn maar Piet heeft er [weinig [*e*]].  
       Jan has much wine but Piet has ER little

**Raising verb:**

Verbs like *schijnen/lijken* ‘to seem’ and *blijken* ‘to appear’ allow the subject of an infinitival object clause to surface as the subject of the main clause. This can be illustrated by means of the examples in (i): the noun phrase functioning as the subject of the finite clause in (ia) surfaces as the subject of the main clause in (ib).

- (i) a. Het schijnt [dat Jan ziek is].  
 it seems that Jan ill is  
 ‘It seems that Jan is ill.’  
 b. Jan schijnt [<sub>t<sub>i</sub></sub> ziek te zijn].  
 Jan seems ill to be  
 ‘Jan seems to be ill.’

It is generally assumed that Raising verbs are °unaccusative verbs. This implies that the anticipatory pronoun in (ia) is an internal °argument of the verb, and that in (ib) the noun phrase *Jan* is moved into the subject position of the clause by means of °NP-movement, which accounts for the °trace in the subject position of the infinitival clause. The movement of the subject is often referred to as °subject raising.

**Reconstruction effect:**

The phenomenon that a certain phrase is not interpreted in its surface position but in some position it occupied before °movement. For example, since the °binding conditions require an anaphor like *zichzelf* to have a °c-commanding antecedent, we must assume that in (i) this condition cannot be satisfied by the anaphor in clause-initial position: it seems as if it is “reconstructed” into its original position indicated by the trace *t<sub>i</sub>*. In the current version of generative grammar, reconstruction is used as a purely descriptive term, as it is assumed that, e.g., conditions on °syntactic dependencies like the binding conditions do not apply to the moved element itself, but to *chains* formed by a moved element and its trace/phonetically empty copy.

- (i) Zichzelf<sub>i</sub> bewondert Jan <sub>t<sub>i</sub></sub> het meest.  
 himself admires Jan the most  
 ‘Himself, Jan admires the most.’

**Recoverability condition on deletion:**

A restriction that states that an element can be deleted only if it is fully determined and therefore recoverable by a structurally related phrase. The precise definition of *determined* and *structurally related* is still subject to discussion but the condition as such seems uncontroversial. The condition was first discussed in generative grammar in Chomsky (1964/1965), and played an important role in Chomsky & Lasnik’s (1977) analysis of English relative clauses.

**Relativized Minimality effect:**

The phenomenon that movement of an element across an element of the same or a similar type is prohibited. For example, in (ib), movement of the direct object across the subject into the position preceding the empty interrogative complementizer  $\emptyset$  is impossible due to the fact that they are both *wh*-phrases. The only way of deriving

an acceptable embedded interrogative clause is by placing the subject in the position preceding  $\emptyset$ , as in (ia).

- (i) a. Ik weet niet [ $wie_i \emptyset [t_i$  wat gelezen heeft]].  
 I know not who what read has  
 ‘I don’t know who read what.’  
 b. \*Ik weet niet [wat $_j \emptyset [$  wie  $t_j$  gelezen heeft]].

### R-extraction:

In Dutch,  $\circ$ preposition stranding by means of movement of an NP-complement of the adposition is impossible; It can only be effected by means of extraction of an  $\circ$ R-pronoun (*er/waar*) from pronominal PPs like *er onder* ‘under it’ or *waar onder* ‘under what’. Stranding of the preposition may be the result of, e.g., scrambling of the R-pronoun, as in (ia), or *wh*-movement or relativization, as in (ib&b’). Our general practice is to use italics to indicate the parts of the discontinuous PP. A comprehensive discussion of R-extraction is given in Section P5.3.

- (i) a. Jan heeft *er* gisteren *naar* gevraagd.  
 Jan has there yesterday for asked  
 ‘Jan asked for it yesterday.’  
 b. *Waar* heeft Jan *naar* gevraagd?  
 where has Jan for asked  
 ‘What did Jan ask for?’  
 b’. het boek *waar* Jan *naar* gevraagd heeft  
 the book where Jan for asked has  
 ‘the book that Jan has asked for’

### Right-hand head rule:

A generalization according to which the rightmost member in a morphologically complex word determines the category (as well as other properties) of the complex word; cf. Williams (1981). For example, the compound *draaideur* ‘revolving door’ is a noun, just like its second part *deur* ‘door’, but unlike its first part, the stem of the verb *draaien* ‘to revolve’.

### Right Node Raising:

An ellipsis phenomenon found in coordinated phrases, in which some part in the right periphery of the left conjunct is deleted under strict identity with the rightmost part of the right conjunct, as in (i).

- (i) Jan kocht een blauwe \_\_\_ en Peter kocht een groene auto  
 Jan bought a blue and Peter bought a green car

The name is due to the fact that the construction was originally derived by rightward movement of the apparently deleted element simultaneously from the left and the right conjunct; cf.  $\circ$ across-the-board movement. This particular movement analysis is controversial given that it forces us to assume movements which are not independently motivated: in (i), for example, the movement analysis would have to assume that the head noun *auto* can be extracted from the complex noun phrase *een blauwe/groene auto*, which is not attested in more uncontroversial cases of leftward movement.



**R-pronominalization:**

The process of creating a pronominal PP, that is, a PP consisting of a preposition and an °R-pronoun.

**R-pronoun:**

In Dutch, prepositions cannot be followed by third person neuter pronouns like *het* ‘it’. So, whereas (ia) is fully acceptable, (ib) is excluded: the neuter pronoun is obligatorily replaced by a so-called R-pronoun *er/daar/ergens/...*, as in (ib’). Occasionally, the replacement by an R-pronoun is optional, e.g., in the case of the quantificational pronouns *iets* ‘something’ or *niets* ‘nothing’ in (ic). See Section P5.2 for extensive discussion.

- |     |    |  |  |
|-----|----|--|--|
| (i) | a. | naar hem/haar ‘to him/her’             |  |
|     | b. | *naar het                              | b’. er naar ‘to it’                          |
|     | c. | naar (n)iets<br>‘to something/nothing’ | c’. (n)ergens naar<br>‘to something/nothing’ |

**Scope:**

In semantics, the scope of an operator is that part of a formula that it combines with; if  $\forall x$  combines with a formula  $\phi$  thus forming the formula  $\forall x(\phi)$ , all elements included by  $\phi$  are in the scope of the operator  $\forall x$ . In generative grammar it is assumed that syntactic operators such as *iemand* ‘someone’, *iedereen* ‘everyone’, *niet* ‘not’, *wie* ‘who’ and *wat* ‘what’ are scope-taking operators. The scope of these elements may or may not be reflected by their actual position in the sentence. By extension, we will also use the notion to indicate which part of the structure is modified by a given modifier.

**Scrambling:**

The word order of Dutch in the °middle field of the clause is relatively free. Generally speaking, this is accounted for by assuming that Dutch has a set of “short” leftward movements that target clause-internal positions. In this way constituents may be moved across adverbial phrases, thus giving rise to word order variation. This is illustrated in (i).

- |     |    |  |
|-----|----|--|
| (i) | a. | Jan zal waarschijnlijk morgen dat boek kopen.<br>Jan will probably tomorrow that book buy<br>‘Jan will probably buy that book tomorrow.’ |
|     | b. | Jan zal waarschijnlijk dat boek morgen kopen.  |
|     | c. | Jan zal dat boek waarschijnlijk morgen kopen.  |

Scrambling is not a unitary phenomenon but actually functions as a cover term for several types of movement. In the prototypical case, scrambling is related to the information structure of the clause. In an example such as (ia), in which the noun phrase *het boek* is not scrambled, the noun phrase typically belongs to the °focus (“new” information) of the clause. In (ic), where it is scrambled, it belongs to the presupposition (“old” information) of the clause; it is rather the adverb *morgen* that constitutes the focus of the clause. Scrambling can, however, also apply for other reasons. In (iia’), for example, the scrambled AP *zo aardig* is assigned emphatic focus, and in (iib’), scrambling of the PP *voor niemand* is forced due to the presence of negation on the nominal complement of the preposition.

- (ii) a. dat Jan nog nooit zo aardig geweest is.  
 that Jan yet never that kind been is  
 ‘that Jan has never been that kind before.’  
 a’. dat Jan ZO aardig nog nooit geweest is.  
 b. <sup>°</sup>dat Jan aardig voor niemand is.  
 that Jan kind for nobody is  
 ‘that Jan isn’t kind for anybody.’  
 b’. dat Jan voor niemand aardig is.

There are many controversies concerning the nature of scrambling, including the question as to whether movement is involved, and, if so, whether this movement has properties normally associated with A-movement (like the movement that places the subject into the regular subject position), or with A'-movement (like *wh*-movement or topicalization), or with both; cf. °Webelhuth’s paradox. There is a vast literature on scrambling; here we mention only some important more recent contributions: Verhagen (1986), Vanden Wyngaerd (1988/1989), Grewendorf & Sternefeld (1990), De Hoop (1992), Corver and Van Riemsdijk (1994), Neeleman (1994b), and Broekhuis (2000/2008).

### Second order predicate:

Second order predicates are predicates that denote properties, not entities, and are characterized by the fact that their °subject is itself a predicate, which therefore need not be a noun phrase; typical examples are given in (i). In the generative literature the use of predicates as SUBJECTS in constructions of the type in (i) is sometimes referred to in terms of the notion “honorary NP”; cf. Safir 1983.

- (i) a. Onder het bed is een goede schuilplaats.  
 under the bed is a good hiding place  
 b. Rood is een mooie kleur.  
 red is a nice color

### Sentence accent:

The sentence accent is located near the end of the clause. It involves a sudden pitch lowering and is normally located on some phrase preceding the clause-final main verb; see Baart (1987), Gussenhoven (1992), Booij (1995), and references given there. A prototypical example is given in (i), with sentence accent indicated by small caps.

- (i) Jan heeft waarschijnlijk het BOEK gekocht.  
 Jan has probably the book bought  
 ‘Jan has probably bought the book.’

Cinque (1993) has argued that stress prominence is a reflection of depth of embedding: the default location of the sentence accent is the most deeply embedded accented constituent in the surface structure of the clause. This correctly derives that in a transitive structure such as (i) the sentence accent should be located on the verb’s object (unless it has been moved into some higher position). We refer the reader to Section V13.1, sub III, for more detailed discussion.

### Small clause:

See °logical SUBJECT.

**Stacking:**

The term stacking refers to constructions containing two or more modifiers of the same kind, in which one modifier has °scope over the other. Some examples of constructions with stacked restrictive relative clauses are given in (i).

- (i) • Stacked restrictive relative clauses
- a. De [[student<sub>i</sub> [die<sub>i</sub> hier net was]]<sub>j</sub> [die<sub>j</sub> Engels studeert]] is mijn vriend.  
 the student who here just was who English studies is my friend  
 ‘The student who was just here who studies English is my friend.’
- b. De [[man<sub>i</sub> [die<sub>i</sub> hier net was]]<sub>j</sub> [die<sub>j</sub> Russisch sprak]] is een bekend schrijver.  
 the man who here just was who Russian spoke is a well-known writer  
 ‘The man that was just here who spoke Russian is a well-known writer.’

As indicated by the bracketing and indexing, the first relative clause in (ia) modifies the antecedent *student* ‘student’, while the second relative clause modifies the sequence *student die hier net was* ‘student who was just here’. The structure of these sentences differs from those in examples (iia&b), which illustrate cases of nesting and coordination, respectively. In (iia), the second relative clause modifies an element contained in the first relative clause; in (iib), the two relative clauses modify the same antecedent.

- (ii) a. De man<sub>i</sub> [die<sub>i</sub> gisteren een boek<sub>j</sub> kocht [dat<sub>j</sub> over WO II gaat]] is mijn vriend.  
 the man who yesterday a book bought which about WW II goes is my friend  
 ‘The man who bought a book yesterday which is about the war is my friend.’
- b. De man<sub>i</sub> [die<sub>i</sub> hier net was] en [die<sub>i</sub> Russisch sprak] is een bekend schrijver.  
 the man who here just was and who Russian spoke is a well-known writer  
 ‘The man who was just here and who spoke Russian is a well-known writer.’

**Stage/Individual-level predicate:**

A stage-level predicate expresses a transitory property of the entity it is predicated of. The Stage-level predicates are distinct from individual-level predicates, which denote a more permanent property. This distinction seems to be syntactically relevant in several respects. Stage-level adjectives, for instance, can be used in (i) expletive copula, (ii) resultatives and (iii) absolute *met*-constructions, (iv) allow the copula *worden* ‘to become’, and (v) can be combined with a time adverb such as *vandaag*. All these patterns lead to anomalous results in the case of individual-level adjectives; see Diesing (1992) for more information.

- (i) a. Er is iemand ziek/<sup>??</sup>intelligent.  
 there is someone ill/intelligent
- b. De spaghetti maakte Jan ziek/<sup>??</sup>intelligent.  
 the spaghetti made Jan ill/intelligent
- c. [Met Jan ziek/<sup>??</sup>intelligent] kan de vergadering niet doorgaan.  
 with Jan ill/intelligent can the meeting not take-place
- d. Jan wordt ziek/<sup>??</sup>intelligent.  
 Jan becomes ill/intelligent
- e. Jan is vandaag ziek/\*intelligent.  
 Jan is today ill/intelligent

**State-of-affairs:**

See °eventuality

**Stranding:**

See °pied piping

**String-vacuous movement:**

Movement that does not cross any phonetically realized element and cannot be seen in the output as a result. For example, while the relative order of the direct object and the finite verb in the (a)-examples in (i) provide evidence for the claim that finite verbs move into second position in main clauses, such evidence is lacking in the (b)-examples. Nevertheless, we assume that movement of the finite verb also takes place in such cases.

- |     |    |   |  |
|-----|----|---|--|
| (i) | a. | dat Jan het boek leest.<br>that Jan the book reads<br>'that Jan is reading the book.' | a'. Jan leest het boek $t_{leest}$<br>Jan reads the book<br>'Jan is reading the book.' |
|     | b. | dat Jan slaapt.<br>that Jan sleeps<br>'that Jan is sleeping.'                         | b'. Jan slaapt $t_{slaapt}$ .<br>Jan sleeps<br>'Jan is sleeping.'                      |

**Strong noun phrase:**

See °weak.

**SUBJECT (vs. subject):**

See °logical SUBJECT.

**Subject raising**

The phenomenon that the argument interpreted as the °logical SUBJECT of an infinitival clause is grammatically realized as the nominative subject of a higher matrix clause. This phenomenon can be aptly illustrated by means of the near equivalent examples in (i), where the subject of the infinitival clause in (ia) appears as the subject of the entire construction in (ib). The standard generative analysis of examples like these is that the subject of the embedded clause is promoted to subject of the matrix clause in order to be assigned case.

- |     |    |   |
|-----|----|---|
| (i) | a. | Het schijnt dat Jan een nieuwe auto koopt.<br>it seems that Jan a new car buys<br>'It seems that Jan is buying a new car.'            |
|     | b. | Jan <sub>i</sub> schijnt [ $t_i$ een nieuwe auto te kopen].<br>Jan seems a new car to buy<br>'that Jan seems to be buying a new car.' |

**Successive cyclic movement:**

Most movements are clause-bound. In order to account for apparent exceptional examples such as (ia), in which a *wh*-phrase has been extracted from an embedded clause, it has been argued that *wh*-movement may apply in a series of shorter steps limited to cyclic phases. The first phase in the derivation of (ia) consists of the most deeply embedded clause: the *wh*-phrase is moved into the first position of this clause, as in (ib). After this phase is closed, the embedded clause becomes opaque

for movement except for its first position, which thus functions as an escape hatch for the *wh*-phrase in the next cyclic phase: the *wh*-phrase can be moved from the first position of the embedded clause into the first position of the next matrix clause, which happens to be the main clause in (ib); example (ic) illustrates the resulting structure for (ia).

- (i) a. Wat denk je dat Peter zal kopen?  
 what think you that Peter will buy  
 ‘What do you think that Peter will buy?’  
 b. — denk je [wat<sub>i</sub> dat Peter t<sub>i</sub> zal kopen]  
 c. Wat<sub>i</sub> denk je [t’<sub>i</sub> dat Peter t<sub>i</sub> zal kopen]

### Superior/superiority:

Superiority refers to an asymmetric relation between the constituents in a phrase, which is generally defined in structural terms of a tree diagram: some constituent A is superior to constituent B if A °c-commands B, but B does not c-command A. This notion is slightly more restricted than the notion of c-command. For example, the verb *wachten* in *Jan wacht [op zijn vader]* c-commands the PP *op zijn vader* as well as all elements contained in it (the preposition *op*, the noun phrase *zijn vader*, the possessive pronoun *zijn* and the noun *vader*), but the verb is only superior to the elements contained within the PP, due to the fact that the PP also c-commands the verb. For the constituents mentioned in the c-command hierarchy in (i), c-command and superiority are interchangeable notions (although they may in principle have different extensions if we apply the definition of c-command strictly in structural terms, depending on the overall structure of the grammar).

- (i) **C-command hierarchy:** subject > indirect object-NP > direct object >  
 indirect object-PP > PP-complement > adjunct

### Superiority condition:

The superiority condition (Chomsky 1973) states that if a transformation can in principle be applied to two constituents in the structure, it has to be applied to the superior one. For the constituents mentioned in our c-command hierarchy in (i), c-command and superiority are interchangeable notions. More recent (relativized) versions of the superiority condition are the Relativized Minimality Condition proposed in Rizzi (1990) and the Locality Conditions proposed in Chomsky (1995) and later work.

- (i) **C-command hierarchy:** subject > indirect object-NP > direct object >  
 indirect object-PP > PP-complement > adjunct

### Supplementive:

Supplementives (which are sometimes also called depictives) are constituents of the clause that denote a property of the subject or the direct object. This is illustrated in (ia&b) by means of supplementive adjectives. In (ia), the adjective *dronken* ‘drunk’ denotes a property of the subject *Jan*, and in (ib) the adjective *leeg* ‘empty’ denotes a property of the direct object *de fles* ‘the bottle’.

- (i) a. *Jan ging dronken naar huis.*  
 Jan went drunk to home  
 ‘Jan went home drunk.’
- b. *Marie zet de fles halfleeg in de kast.*  
 Marie puts the bottle half-empty into the cupboard  
 ‘Marie is putting the bottle in the cupboard half-empty.’

The relation between the supplementive and the clause is one of “simultaneousness” or “material implication”. The property expressed by the supplementives in (i) holds at the same time as the action expressed by the clause. Example (ib), for instance, can be paraphrased as “Marie puts the bottle in the cupboard *while* it is empty”. In (ii), we give an example in which the relation is a material implication: “that you will iron your shirt smoother *if* it is wet”. The supplementive is extensively discussed in Section A6.3.

- (ii) dat je je overhemd nat gladder strijkt.  
 that you your shirt wet smoother iron  
 ‘that you will iron your shirt smoother wet.’

### Syntactic Dependency:

There are two types of syntactic dependency: local and non-local. Local restricted syntactic dependencies are characterized by the four properties in (i); see Koster (1987). A prototypical example of a local syntactic dependency is °binding of reflexive and reciprocal pronouns: they must have a unique c-commanding antecedent within a certain anaphoric domain.

- (i) a. obligatoriness  
 b. uniqueness of antecedent  
 c. c-command of the antecedent  
 d. locality

Non-local syntactic dependencies may exhibit some but not all of the properties in (i): the antecedent of referential pronouns, for example, may c-command the pronoun while it is not in its local domain (like *Jan* in (iia)) or be in its local domain while it does not c-command it (like *Jan* in (iib)), but it cannot simultaneously c-command the pronoun and be in its local domain (like *Peter/Peter’s vader* in (ii)).

- (ii) a.  $Jan_i$  zei [dat  $Peter_j$  hem<sub>i/\*j</sub> gebeld had].  
 Jan said that Peter him called had  
 ‘Jan said that Peter had called him.’
- b. [ $Jans_j$  vader]<sub>k</sub> heeft hem<sub>i/\*k</sub> gebeld.  
 Jan’s father has him called  
 ‘Jan’s father has called him.’

### Telic:

A telic verb is a verb like *vallen* ‘to fall’ that denotes an event with a natural end point, whereas an atelic verb is a verb like *huilen* ‘to cry’ that lacks such a natural end point. Some researchers object to the notions of (a)telic verb, since telicity need not be a property of the verb, but of the larger structure that the verb occurs in. For

example, the verb *wandelen* ‘to walk’ in a sentence like *Jan wandelt* ‘Jan is walking’ refers to an atelic event, but the addition of a (predicative) locational phrase may introduce a terminal point and thus make the construction as a whole telic: *Jan wandelt naar huis* ‘Jan is walking home’. The shift in telicity often goes hand in hand with a shift in the syntactic status of the verb: *wandelen* behaves like an intransitive verb in *Jan wandelt* but as an °unaccusative verb in *Jan wandelt naar huis*.

**Thematic relation:**

See °thematic role.

**Thematic role:**

A thematic role is a formal means to express the semantic relation between a head and its °arguments. It is often assumed that arguments can be assigned different thematic roles, e.g., AGENT, THEME (or PATIENT), GOAL and SOURCE.

**Topicalization:**

Topicalization is a movement operation that places some constituent into the clause-initial position of a main clause, that is, into the position in front of the finite verb. In (i), the italicized phrases are topicalized, although it has been suggested that the subject NP in (ia) has not been topicalized but occupies the regular subject position; cf. V6.1.2 and Zwart (1993/1997) for relevant discussion.

- (i) a. *Marie* heeft dat boek gisteren op de markt gekocht.  
Marie has that book yesterday at the market bought  
‘Marie bought that book at the market yesterday.’
- b. *Dat boek* heeft Marie gisteren op de markt gekocht.
- c. *Gisteren* heeft Marie dat boek op de markt gekocht.
- d. *Op de markt* heeft Marie gisteren dat boek gekocht.

From a pragmatic point of view, a topicalized phrase can have several functions. It may be the topic of discourse: in (ia), for example, the discussion is about Marie, in (ib) about the book, etc. The topicalized phrase may also be used contrastively, for instance to contradict some (implicitly or explicitly made) supposition in the discourse, as in (ii). In these cases, the topicalized phrase receives contrastive accent.

- (ii) a. *MARIE* heeft het boek gekocht (niet JAN).  
Marie has the book bought not Jan
- b. *BOEKEN* heeft ze gekocht (geen PLATEN).  
books has she bought not records

**Trace (t):**

A formal means of representing °movement. The moved constituent and its trace are coindexed. In the more recent generative literature, trace theory is replaced by Chomsky’s (1995:ch.3) copy theory of movement, that is, the claim that movement is a copy-and-paste operation that leaves an actual copy of the moved constituent in its original position. The constant factor in the two theories is that the moved element enters into a chain with its trace/copy, which must satisfy certain locality



conditions. For reasons of space, we will normally use traces in our syntactic representations without intending to express any theoretical bias in favor of trace theory.

There are (at least) two main types of chains. A(argument)-chains contain traces created by A-movement, also known as NP-movement, which moves/copies a noun phrase from one argument position into another where it can, e.g., be assigned case (as in passive, unaccusative and subject raising constructions).

- (i) [Het boek]<sub>i</sub> wordt door Peter  $t_i$  gekocht.  
 the book is by Peter bought  
 ‘Jan is bought by Peter.’

A'-chains are created by A'-movements like *wh*- or *neg*-movement, which places a constituent in a non-argument position where it can be assigned a specific semantic or discourse function.

- (ii) [Welk boek]<sub>i</sub> heeft Jan  $t_i$  gekocht?  
 which book has Jan bought  
 ‘Which book has Jan bought?’

**Triadic verb:**

See °adicity.

**Unaccusative verb:**

Unaccusative verbs never take an accusative object. The subject of these verbs entertain a similar semantic relation with the unaccusative verb as the direct object with a transitive verb. This is quite clear in the pair in (i); the nominative noun phrase *het glas* ‘the glass’ in the unaccusative construction (ib) has the same relation to the verb as the accusative noun phrase *het glas* in the transitive construction in (ia).

- (i) a. Jan breekt het glas.  
 Jan breaks the glass  
 b. Het glas breekt.  
 the glass breaks

It is assumed that the subject in (ib) originates in the regular direct object position but is not assigned accusative case by the verb, so it must be moved into subject position, where it can be assigned nominative case. For this reason, we call the subject of an unaccusative verb a °DO-subject. The fact that (ib) has a transitive alternant is an incidental property of the verb *breken* ‘to break’. Some verbs, such as *arriveren* ‘to arrive’, only occur in an unaccusative frame.

It is often assumed that regular intransitive verbs and unaccusative verbs have three distinguishing properties: (a) intransitives take the perfect auxiliary *hebben* ‘to have’, whereas unaccusatives take the auxiliary *zijn* ‘to be’; (b) the past/passive participle of unaccusatives can be used attributively to modify a head noun that corresponds to the subject of the verbal construction, whereas this is not possible with intransitive verbs; (c) the impersonal passive is possible with intransitive verbs only. These properties are illustrated in (ii) by means of the intransitive verb *lachen*

‘to laugh’ and the unaccusative *arriveren* ‘to arrive’, cf. Hoekstra (1984a). See Section V2.1.2 for a comprehensive discussion.

- |      |   |                |  |
|------|---|----------------|--|
| (ii) | • Intransitive                                | • Unaccusative |  |
| a.   | Jan heeft/*is gelachen.<br>Jan has/is laughed | b.             | Jan is/*heeft gearriveerd.<br>Jan is/has arrived |
| a’.  | *de gelachen jongen<br>the laughed boy        | b’.            | de gearriveerde jongen<br>the arrived boy        |
| a’’. | Er werd gelachen.<br>there was laughed        | b’’.           | *Er werd gearriveerd.<br>there was arrived       |

There are, however, cases that show only part of the prototypical behavior of unaccusative verbs. Locational verbs like *hangen*, for example, enter an alternation similar to the verb *breken* in (i), but nevertheless the verb *hangen* in (iiib) does not exhibit the behavior of the verb *arriveren* in (ii). It has been suggested that this might be due to the fact that there is an aspectual difference between the verbs *arriveren* and *hangen*—the former is telic whereas the latter is not; see Section V2.1.2, sub III.

- (iii) a. Jan hangt de jas in kast.  
Jan hangs the coat into the wardrobe
- b. De jas hangt in de kast.  
the coat hangs in the wardrobe

**Undative verb:**

Undative verbs like *hebben* ‘to have’ or *krijgen* ‘to get’ (ib) never take a dative object. The subjects of undative verbs entertain a similar semantic relation with the undative verb as indirect objects with ditransitive verbs such as *geven* ‘to give’ in (ia).

- (i) a. Peter geeft Marie een boek.  
Peter gives Marie a book
- b. Marie krijgt/heeft een boek.  
Marie gets/has a book

We assume that the subject in originates in the regular indirect object position but is not assigned accusative case by the verb, so it must be moved into subject position, where it can be assigned nominative case. Whereas assuming a category of unaccusative verbs is relatively uncontroversial, a category of undative verbs is not yet widely recognized.

**Unergative verb:**

Unergative verbs, as distinct from °unaccusative verbs, can in principle assign accusative case. This set of verbs includes the intransitive, transitive and ditransitive verbs. Since intransitive verbs like *wandelen* ‘to walk’ do not take a direct object they normally do not assign case: cf. (ia). The two (b)-examples show, however, that such verbs are able to assign case to direct objects semantically licensed by a °complementive like *kapot* ‘broken’. We refer the reader to Section V2.3.3 for more discussion of examples like (ib).

- (i) a. Jan wandelt (\*zijn schoenen).  
 Jan walks his shoes  
 ‘Jan is walking’
- b. Jan wandelde zijn schoenen kapot.  
 Jan walked his shoes broken  
 ‘Jan walked his shoes to pieces.’

**Verb-final:**

See °Verb-second.

**Verb-second:**

The phenomenon in Dutch that the finite verb normally occupies the so-called second position of the main clause, that is, is preceded by precisely one constituent (see also °constituency test). In embedded clauses the finite verb is placed in clause-final position, just like the non-finite verbs, which is generally considered as its “base”-position; for this reason, verb-second is often used for the movement placing the finite verb in second position.

As technical notions, *verb-second* and *verb-final* are used in strict opposition. This leads to the slightly awkward conclusion that certain verbs that are in final position of a clause do not count as verb-final but as verb-second. For example, main clauses like (ia) consisting of no more than an intransitive verb and its subject do not count as verb-final clauses in the technical sense given that the verb must appear in second position when more material is added; this is shown in (ib).

- (i) a. Jan wandelt.  
 Jan walks  
 ‘Jan is walking.’
- b. Jan <\*graag> wandelt <graag>.  
 Jan gladly walks  
 ‘Jan likes to walk.’

**Verb clustering**

The phenomenon that verbs that are part of a °verbal complex tend to cluster in clause-final position. In main clauses the cluster consists of non-finite verbs only, whereas in embedded clauses the cluster also involves the finite verb. Note that as a result of verb clustering the embedded clause may be split: in (i), for instance, the main verb *lezen* is separated from its argument *een boek* ‘a book’.

- (i) a. Jan *heeft* een boek *zitten lezen*. [main clause]  
 Jan has a book sit read  
 ‘Jan has been reading a book.’
- b. dat Jan een boek *heeft zitten lezen*. [embedded clause]  
 that Jan a book has sit read  
 ‘that Jan has been reading a book.’

**Verbal complex**

The term verbal complex is used as a translation of the term *werkwoordelijk gezegde* from traditional grammar. A verbal complex typically consists of a main verb, which may be supplemented by one or more non-main verbs. In the examples

in (i), we find verbal complexes consisting of, respectively, one, two and three verbs. The complexes are given in italics. A characteristic property is that the non-finite verbs tend to cluster in clause-final position, as in (ic). In embedded clauses the clause-final cluster also includes the finite verb; this is shown in the primed examples of (i). The examples in (i) also show that as a result of clustering the main verb can become separated from its arguments (here: the object *het boek* ‘the book’) by the non main verbs.

- |     |    |  |     |   |
|-----|----|--|-----|---|
| (i) | a. | Jan <i>leest</i> een boek.<br>Jan reads a book<br>‘Jan is reading a book.’                                   | a’. | dat Jan een boek <i>leest</i> .<br>that Jan a book reads<br>‘that Jan is reading a book.’                           |
|     | b. | Jan <i>heeft</i> een boek <i>gelezen</i> .<br>Jan has a book read<br>‘Jan has read a book.’                  | b’. | dat Jan een boek <i>heeft gelezen</i><br>that Jan a book has read<br>‘that Jan has read a book.’                    |
|     | c. | Jan <i>heeft</i> een boek <i>zitten lezen</i> .<br>Jan has a book sit read<br>‘Jan has been reading a book.’ | c’. | dat Jan een boek <i>heeft zitten lezen</i> .<br>that Jan a book has sit read<br>‘that Jan has been reading a book.’ |

A second characteristic property of verb complexes is they may exhibit the °Infinitivus-Pro-Participio effect. In perfect-tense construction the verb governed by the perfect auxiliary cannot appear as a past participle but must appear as an infinitive: this is illustrated in (ii).

- (ii) Jan *heeft* een boek *zitten*/\**gezet* *lezen*.  
Jan has a book sit/sat read  
‘Jan has been reading a book.’

In traditional grammar, it is generally assumed that all verbs except the most deeply embedded one are non-main verbs. This claim is, however, largely due to the fact that the descriptive statement given earlier is often taken to be a definition: a verbal complex consists of at most one main verb, which may be supplemented by one or more non-main verbs. There are, however reasons for not adopting this assumption. For example, it would force us to analyze the verb *zien* ‘to see’ in (iii) as a non-main verb despite the fact that it has a number of prototypical properties of main verbs; for example it takes a pronoun as its complement in pronominalization contexts: *Jan zag dat* ‘Jan saw that’. See Chapter V4 for more extensive discussion.

- (iii) a. dat Jan de lamp zag vallen.  
that Jan the lamp saw fall  
‘that Jan saw the lamp fall.’  
b. dat Jan de lamp heeft zien/\*gezien vallen.  
that Jan the lamp has see/seen fall  
‘that Jan has seen fall the lamp.’

### **VP adverbial:**

See °adverbial tests.

**VP-topicalization:**

Topicalization of a projection of the main verb. This construction is possible only if an auxiliary verb or the semantically empty verb *doen* 'to do' is present. Some examples are given in (ia).

- (i) a. [<sub>VP</sub> Die boeken lezen]<sub>i</sub> wil ik niet *t<sub>i</sub>*.  
           those books read want I not  
           'I don't want to read those books.'
- b. [<sub>VP</sub> Dat boek gelezen]<sub>i</sub> heb ik niet *t<sub>i</sub>*.  
           that book read have I not  
           'I haven't read that book.'
- c. [<sub>VP</sub> Dat boek lezen]<sub>i</sub> doe ik niet *t<sub>i</sub>*.  
           that book read do I not  
           'I don't read that book.'

Occasionally, topicalization of the verb strands the direct object. Still, it can be maintained that in that case a projection of the verb has also been moved into sentence-initial position. The only reason that the examples in (ii) appear to involve movement of the verb in isolation is that the direct object has been scrambled out of the VP, so that what is moved into sentence-initial position is a VP containing the trace of the direct object.

- (ii) a. [<sub>VP</sub> *t<sub>j</sub>* Lezen]<sub>i</sub> wil ik die boeken<sub>j</sub> niet *t<sub>i</sub>*.  
       b. [<sub>VP</sub> *t<sub>j</sub>* Gelezen]<sub>i</sub> heb ik dat boek<sub>j</sub> niet *t<sub>i</sub>*.  
       c. [<sub>VP</sub> *t<sub>j</sub>* Lezen]<sub>i</sub> doe ik dat boek<sub>j</sub> niet *t<sub>i</sub>*.

**Weak:**

The notions WEAK and STRONG have two different uses, depending on whether we are dealing with pronouns, or with noun phrases, determiners and quantifiers.

I. The notions of WEAK and STRONG pronouns refer to the phonetic shape of the pronouns: the former refers to the phonetically reduced form and the latter to the phonetically non-reduced form. Note that the weak pronouns sometimes have specialized meaning and can therefore be assumed to be stored in the lexicon.

II. An easy way to distinguish WEAK and STRONG NOUN PHRASES is to consider their behavior in °expletive constructions; cf., e.g., Milsark (1974/1977) and Barwise & Cooper (1981). Whereas weak noun phrases can be part of such constructions, strong ones may not. Example (ia) shows that indefinite noun phrases are weak. Example (ib) is only acceptable on a generic reading, which shows that generic noun phrases are strong.

- (i) a. Er loopt een kat op het dak.  
           there walks a cat on the roof  
           'There is a cat walking on the roof.'
- b. #Een kat loopt op het dak.  
           a cat walks on the roof

Whether a given noun phrase is weak or strong depends on the determiner or quantifier it contains, which, by extension, can therefore also be qualified as weak

and strong. The examples in (ii) show that noun phrases containing a numeral or a quantifier like *veel* ‘many’ may be either weak or strong. This difference goes hand in hand with a semantic distinction: the weak noun phrases receive an existential interpretation in the sense that they introduce new entities into the domain of discourse, whereas the strong ones receive a partitive reading in the sense that they refer to a subset of a larger set of entities already present in the domain of discourse.

- (ii) a. Er lopen twee/veel katten op het dak.  
 there walk two/many cats on the roof  
 ‘There are two/many cats walking on the roof.’  
 b. Twee/veel katten lopen op het dak.  
 two/many cats walk on the roof  
 ‘Two/Many of the cats walk on the roof.’

The examples in (iii), finally, show that definite noun phrases and noun phrases containing a quantifier like *alle* are strong.

- (iii) a. \*Er lopen de/alle katten op het dak.  
 there walk the/all cats on the roof  
 b. De/alle katten lopen op het dak.  
 the/all cats walk on the roof

### Webelhuth’s paradox:

Webelhuth’s paradox refers to the fact that scrambling seems to exhibit simultaneously properties of A-movement (the type of movement applied to the subject in passive constructions) and A’-movement (like *wh*-movement or topicalization). For example, the fact that scrambling feeds binding is a typical A-movement property (cf. Van den Wyngaerd 1988/1989), whereas the fact that scrambling licenses parasitic gaps is generally considered an A’-movement property (cf. Bennis and Hoekstra 1984). The binding facts are illustrated in (i), and the parasitic gap facts in (ii).

- (i) a. \*Hij heeft namens *elkaar* *de jongens* bezocht.  
 he has on behalf of each other the boys visited  
 b. Hij heeft *de jongens*<sub>i</sub> namens *elkaar* *t<sub>i</sub>* bezocht.  
 he has the boys on behalf of each other visited  
 ‘He visited the boys on behalf of each other.’  
 (ii) a. \*Hij heeft [zonder PRO *PG* te bekijken] *het boek* opgeborgen.  
 he has without to look-at the book prt-filed  
 b. Hij heeft *het boek*<sub>i</sub> [zonder PRO *PG* te bekijken] *t<sub>i</sub>* opgeborgen.  
 he has the book without to look-at prt-filed  
 ‘He filed the book without looking (at it).’

A plausible solution to Webelhuth’s paradox is to assume that the notion of scrambling is not a unitary phenomenon, but actually refers to (at least) two different types of movement (cf. Vanden Wyngaerd 1988/1989; Déprez 1989; Mahajan 1990/1994; Neeleman 1994b). The fact that the object in (iii) is able to bind the anaphor as well as to license the parasitic gap can then be accounted for as

follows: the object is not moved into its surface position in one fell swoop, but in two steps. The first step involves A-movement and enables binding of the anaphor *elkaar* 'each other'. The second step involves A'-movement and licenses the parasitic gap.

- (iii) Hij had *de gasten*<sub>i</sub> [zonder *pg* te bekijken] *t*'<sub>i</sub> aan *elkaar* *t*<sub>i</sub> voorgesteld.  
 he had the guests without to look-at to each other introduced  
 'He had introduced the guests to each other without looking (at them).'

**Wh-movement:**

Movement of some constituent into clause-initial position. The name is derived from the fact that in English the moved constituent often contains a *wh*-phrase such as *who*, as in the embedded *wh*-question in *I wonder [who will be there]* and the relative clause in *the man [who was there]*. However, the term *wh*-movement refers not only to movements in interrogative and relative constructions but also to movements in exclamative and topicalization constructions. Example (i) gives a sample of cases in Dutch that are derived by means of *wh*-movement; we refer the reader to section V9.3.3 for a more detailed discussion.

- (i) a. Wat<sub>i</sub> heb je vandaag *t*<sub>i</sub> gedaan? [wh-question]  
 what have you today done  
 'What did you do today?'  
 b. de man [die<sub>i</sub> ik gisteren *t*<sub>i</sub> gesproken heb] [relative clause]  
 the man that I yesterday spoken have  
 'the man who I spoke to yesterday'  
 c. [Wat een leuk boek]<sub>i</sub> heb je hem *t*<sub>i</sub> gegeven! [exclamative]  
 what a nice book have you him given  
 'What a nice book you've given him!'  
 d. [Dat boek]<sub>i</sub> heb ik gisteren *t*<sub>i</sub> gelezen. [topicalization]  
 that book have I yesterday read  
 'That book, I read yesterday.'





# Index (verbs and verb phrases 1-3)

## A

- A/A'-  
— movement *See Movement and Scrambling*  
— position *See Position*
- Aan het* + infinitive + *zijn* *See Aan het* + infinitive + *zijn construction*
- Accent  
— and topicalization 1378, 1482  
— in multiple *wh*-questions 1465
- Contrastive — 314, 336, 485, 505, 518, 779, 782, 799, 909, 924, 1081, 1289, 1357, 1409, 1480, 1492, 1504, 1631, 1669, 1757, 1784  
Accent A versus Accent B 1703
- Sentence — 754, 1489, 1618, 1667, 1686, 1782, 1783  
Word — 78
- Accomplishment 40, *See also Vendler's event classification*
- Accusativus-cum-infinitivo *See AcI-construction*
- Achievement 42, *See also Vendler's event classification*
- achten* 'to consider' *See Passive Subject Raising Construction*  
— + *te*-infinitive 1053
- AcI-construction 408, 434, 458, 520, 636, 944, 967, §5.2.3.4 (p.918), §5.2.3.3 (p.899)
- Across-the-board movement 1460
- Activity 40, *See also Vendler's event classification*
- Adicity 29, 986, 987
- Adjective  
— phrase 1423, 1435  
Gradable — 1522
- Adposition  
*van* 926  
*volgens* 926
- Adpositional phrase 1421, 1426  
Directional — 538, 548  
Locational — 538, 548
- Adverb *See also Adverbial*, §8.3.1
- Adverbial 169, Chapter 8 (p.1119)  
— clause 1224  
— proform 299, 1232, §8.3.2 (p.1170)  
— tests 305, 1167
- Agentive — *See Agentive door-phrase and Comitative met-phrase*
- Aspectual — 1189, 1229, 1242
- Cause — 1181, 1197, 1227, 1239
- Clause — 1662, 1672, §8.1 (p.1120), §8.2.2 (p.1139), §8.3.3 (p.1181), §8.4 (p.1185)  
— versus VP adverbial §8.1 (p.1120)

1782 *Syntax of Dutch: Verbs and verb phrases*

Clause-degree —	1190, 1229, 1242
Concession —	1181, 1198, 1199, 1227
Condition —	1199, 1231
Conjunctive —	1200, 1247
Contingency —	<i>See Cause, Purpose, Reason, Result and Concession adverbial</i>
Domain —	1172, 1199, 1218, 1232, 1237, 1246, 1495
Event-related —	1495
Frame —	<i>See Domain adverbial</i>
Frequency —	168, 181, 1179, 1226
Instrument —	1172, 1217, 1236
Locational —	1175, 1197, 1211, 1219, 1231, 1238, 1244, §8.2.3 (p.1168)
Punctual versus distance	1179
Relational versus non-relational —	1180
Manner —	1005, 1172, 1217, 1236
Means —	1172, 1217, 1236
Modal —	141, 1192, 1229, 1242, 1495
Obligatory —	1248
Placement of —s	1166, 1278, 1495, 1652, 1797, §8.4 (p.1185)
Point-of-view —	1195, 1231, 1244
Polarity —	1185, 1229, 1241, <i>See also Negation</i>
Predicate —	<i>See VP adverbial</i>
Predicate-degree —	1183, 1228, 1240
Process —	<i>See Instrument, Manner, Means, Volition and Domain adverbial</i>
Purpose —	1182, 1227, 1239
Reason —	1181, 1197, 1227, 1239
Result —	1227, 1239
Sentence —	<i>See Clause adverbial</i>
Spatio-temporal —	<i>See Locational and Temporal adverbial</i>
Speaker-oriented —	1195, 1202, 1222, 1495
Speech-act related —	1202, 1232, 1246
Subjective —	1194, 1231, 1243
Subject-oriented —	454, 1173, 1193, 1231, 1243
Temporal —	125, 167, 176, 1025, 1175, 1196, 1206, 1220, 1231, 1238, 1244, 1495, §8.2.3 (p.1168)
Durational versus punctual —	1177
Frequentative/iterative —	<i>See Frequency adverbial</i>
Relational versus non-relational —	1177
Speaker-oriented versus tense-sensitive —	1222
Volition —	1172, 1218, 1237
VP —	1662, §8.1 (p.1120), §8.2.1 (p.1127), §8.3.2 (p.1170), §8.4 (p.1185)
— versus clause adverbial	<i>See also Adverbial tests, §8.1 (p.1120)</i>
— versus PP-complement	305
Affectedness	327, 486, 539, 548, 588
Agentive	
— <i>door</i> -phrase	370, 427, 434, 436, 439, 442, 444, 471, 473, 477, 502, 512, 523, 949, 960, 1174, 1218, 1237, §3.2.1 (p.407)
— <i>van</i> -phrase	240, 471

Agreement	
Complementizer —	1262
Subject-verb —	16, 68, 761
Aktionsart	38
<i>als</i>	
Conditional/temporal conjunction —	666, 689, 745
Conjunction — of comparison	692, 730
Predicative — phrase	598
Alternation	<i>See Verb frame alternation</i>
Anticipatory	
— pronominal PP <i>er</i> + P	303, 604, 667, 752, 797, 863, 866, 1448, 1499
— pronoun <i>het</i> ‘it’	667, 683, 684, 688, 689, 699, 712, 744, 748, 759, 795, 796, 863, 865, 972, 1272, 1446, 1499
Apposition	1609
Argument	
— structure	
— of verbs	<i>See also Verb classification</i> , §1.2 (p.19), Chapter 2 (p.181)
AP-complements	§2.4 (p.329)
Clausal arguments	1272, 1651, Chapter 5 (p.639)
Nominal arguments	1272, §2.1 (p.185)
Prepositional object	1274, §2.3 (p.284)
External —	25, 188, 418, §3.2 (p.407)
Internal —	25, 188, 487, 901
Placement of —s in the clause	747, 1271, 1613
Article	
Negative — <i>geen</i> ‘no’	910, 1316, 1320, 1326, 1330
Spurious indefinite — <i>een</i>	<i>See een</i>
Aspect	1062, §1.5.3 (p.150)
Durative —	38
Inchoative —	38, 162
Inner —	<i>See Aktionsart</i>
Iterative —	38
Momentaneous —	38
Progressive —	156
Terminative —	38, 162
Aspectual verb	<i>See Non-main verb</i>
<i>automatisch</i> ‘automatically’	496
Autonomous use of a word/phrase	716
Auxiliary	<i>See Non-main verb</i>
<b>B</b>	
<i>be-</i>	365, 586, 602
Deadjectival verb	365
Denominal verb	585, 590
Deverbal verb	588, 592, 593
Benefactive	§3.3.1.5558 (p.558)

<i>betalen</i> ‘to pay’	296, 315, 333, 450
<i>bij</i> ‘near/at/with’	558
Bijection principle	1536, 1571, 1573
Binding	382, 388, 521, 725, 805, 1688
— and reconstruction	§11.3.6 (p.1493)
— conditions on parasitic gaps and <i>wh</i> -traces	1575, 1600
Bound variable reading of pronouns	455, 713, 725, 772, 1558, 1565, 1767
Movement that bleeds/feeds — options	454
Movement that does not bleed/feed — options	§11.3.6 (p.1493)
No co-argument restriction on — of simplex reflexives	396
Bleaching (Semantic —)	297
<i>blijven</i> ‘to stay’	<i>See Locational/Aspectual verb</i>

## C

Case	757, 959
— absorption	400, 434, 527
— and anaphors	411
— assignment	471, 1273
Accusative —	194
Exceptional — marking	<i>See AcI-construction</i>
Nominative —	194
Causation (direct and indirect)	954
Causative	
— <i>door</i> -phrase	347, 358, 370, 442
— <i>met</i> -phrase	347
— <i>van</i> -phrase	358
Causer/Cause	954
— of emotion	<i>See Psychological predicate</i>
Clause	
— -final position	10, 685, 1259
— -initial position	1258, Chapter 11 (p.1315), §9.3 (p.1215)
— splitting	642, 644, 645, 646, 997, 1015, 1092, <i>See also Verb cluster and Remnant extraposition</i> , §7.1.1 (p.1051)
— structure (overview)	§9.1 (p.1205)
Adverbial —	685, 703, 1445
Argument —	1001, 1445, Chapter 5 (p.639)
Finite —	626, §5.1 (p.641)
Direct object	664, §5.1.2 (p.649)
Placement of —	684, 692, 702
Prepositional object	664, §5.1.4 (p.725)
Subject	664, §5.1.3 (p.717)
Topicalization of —	1499
Infinitival —	626, §5.2 (p.765)
Bare —	636, 793, §6.4 (p.1019)
— versus BARE-INF nominalization	906, 938, 958, 968
Direct object	795

Interrogative —	627
<i>Om + te</i> —	793, 844, §5.2.1 (p.766)
Prepositional object	797
Subject	796
<i>Te-</i> —	793, §5.2.2 (p.802)
Topicalization of —	1500, 1501
Interrogative —	627, 666, 674, 751
Complementive —	<i>See Complementive clause</i>
Conditional —	169, 170, 182, 183, 1232, 1350
Counterfactual —	170, 183
Declarative —	623, 1255
Embedded —	1260, 1380
Factive —	<i>See Factivity</i>
Fragment —	§5.1.5 (p.728)
Answer	755, 776
<i>Wh</i> -question	754, 756
Functional domain of the —	1255
Generic —	169, 181
Habitual —	169, 181
Hypothetical —	169, 182
Infinitival —	<i>See Infinitive and infinitival clause</i>
Interrogative —	623, 1255
Lexical domain of the —	1254
Main —	1258, 1380
Object —	<i>See Argument clause</i>
Parenthetical —	718, 1351
Positions in the —	<i>See Clause-initial position, Verb-second, Middle field, clause-final position, Postverbal field</i>
Prepositional object —	<i>See Argument clause</i>
Relative —	1279, 1635
Free —	670, 687, 976, 1414
Subject —	<i>See Argument clause</i>
Collocation	<i>See Verbal collocation</i>
Common ground (WIDENING of the —)	1527
Comparative	1523
— (sub)deletion	§11.3.5 (p.1486)
— correlative construction	§10.3.1 (p.1291)
— <i>dan/als</i> -phrase	1549, 1644
Complement	<i>See Internal argument</i>
Complementation	
— of verbs	<i>Chapter 2-5</i>
APs	§2.4 (p.329)
Finite clause	663
Infinitival clause	793
Noun phrases	§2.1(p.185)
PPs	294

Complementive	44, 190, 487, 526, 546, 549, 596, 683, 937, 1052, 1297, 1506, 1607, §2.2 (p.239)	
— clause		1446, §5.3 (p.936)
Bare infinitival		979
Finite —		971
<i>Om + te</i> infinitival		977
<i>Te</i> infinitival		978
— versus PP-complement		309
Adjectival —		249
Adpositional —		249
Nominal —		249
Placement of —s		1002, 1281
Complementizer	652, 709, 1255, 1261, 1265, 1298, 1372	
— agreement		1262
— -trace effect		1442
Declarative — <i>dat</i> ‘that’	665, 674, 751, 1349, 1539	
Doubling of —		1353
Infinitival — <i>om</i>	633, 794, 802, 863, 865, 866, 901	
Interrogative — <i>of</i> ‘whether’		666, 1539
Compounding		78, 1307
Conjunction		
Coordinating —		1751
Subordinating —		<i>See complementizer</i>
Conjunctive		965, 1401
Connectivity effects		
— in contrastive left-dislocation constructions		1562
— in relative clauses		1567
Construction		
Aan <i>het</i> + infinitive + <i>zijn</i> —	75, 80, 157, 481, 495, 950, 1101, 1305, 1315, 1317, 1325, 1329, 1330, 1337, 1341	
Absentive —		§6.4.2 (p.1029)
<i>Achten</i> ‘to consider’ + complementive —		259, 673
Cleft —		1479
Comparative (sub)deletion —		<i>See Comparative (subdeletion)</i>
Comparative correlative —		<i>See Comparative correlative construction</i>
Copular —		249, 257, 971
Double object —		<i>See Dative, See Dative</i>
<i>Easy-to-please</i> —		499, 509
Exclamative —		<i>See Exclamative</i>
Expletief —		<i>See Expletive er ‘there’</i>
<i>Geacht worden</i> ‘was expected’- —		<i>See Passive Subject Raising Construction</i>
N of a N —		608
<i>Noemen</i> ‘to consider’ + adjective —		259
Periphrastic indirect object —		<i>See Dative</i>
Pseudo-cleft —		481, 1480
Quotative <i>van</i> - —		711, 729
Resultative —		249, §2.2.3 (p.251)



Semi-copular —	471, 1009, 1027
<i>Vinden</i> 'to consider'- —	249, 259, 673, 683, 795, 937, 975
Control	428, 508, 629, 638, 924, 927, 930, §5.2.1.3 (p.776)
— shift	631, 830
— versus Subject Raising	832, 848, 875
Antecedent	
C-commanding —	822, 826, 834, 838
Local —	827
Overt —	811, 814, 822, 824, 834, 843
Split —	808, 811, 813, 821, 827, 841
Non-obligatory —	806, 810, 812, 821, 844, 872, 876, 878
Object —	631, 805, 817, 839, 898
Obligatory —	810, 812, 834, 844, 872, 876, 878
Semantic restrictions on —	808, 828
Subject —	631, 805, 813, 835, 872
Conversion	
— of verbs	§7.1.2 (p.1055)
bare infinitive to noun	<i>See Nominalization</i>
Past/passive participle to adjective	1096
<i>Te</i> -infinitives to adjective	1098
Coordination	1353
Split —	1646
CP (Complementizer Phrase)	634, 762, 785, 845, 876, 879, §9.1 (p.1205)

## D

Dative	
— shift	420, §3.3.1 (p.515)
— with <i>aan</i> -phrases (recipients)	961, §3.3.1.1 (p.516)
— with <i>bij</i> -phrases (possessors)	553
— with <i>naar</i> -phrases (goals)	538, §3.3.1.2 (p.527)
— with <i>van</i> -phrases (sources)	§13.3.1.3 (p.527)
— with <i>voor</i> -phrases (benefactives)	§3.3.1.5 (p.558)
Ethical —	535
Possessive —	36
Definiteness effect	1443
Deictic center	1060, 1070
Deletion	762
Derivation of verbs	587
Detransitivization	403
Diary drop	69
Direct reported speech	1260, <i>See Direct reported speech</i>
Discourse marker	<i>See Pragmatic marker</i>
Discourse-linking	786, 1579
Dislocation	<i>See Right dislocation and Left dislocation</i>

- doen* 'to do'
- support 1513, 1514, §6.4.3 (p.1041)
  - Causative — 'to make' 357
  - Non-main verb §6.4.3 (p.1041)
- door* 'by'
- Agentive — -phrase *See Agentive door-phrase*
  - Causative — -phrase *See Causative door-phrase*
- DO-subject 32, 196
- Do*-support *See doen* 'to do'
- Double object construction *See Dative*
- duren* 'to last' 342, 1623
- E**
- Easy-to-please* construction *See Easy-to-please construction*
- een*
- Spurious indefinite — 1523, 1536, 1543
- Ellipsis 1648, 1753, 1754, 1780
- Enumeration 1614
- Epithet 1678, 1770
- er*
- Expletive — 'there' 206, 480, 744, 749, 796, 1015, 1443, 1487, 1488, 1509, 1738
  - Locational — 1738
  - Partitive — *See Quantitative er*
  - Prepositional — 1739
  - Quantitative — 1552, 1740
- eren* 366, 542, 1277
- Denominal verb 366
- Erlebte Rede *See Semi-direct reported speech*
- ER-nominalization *See ER-nominalization*
- Exclamative
- *hoe* 1519, 1538
  - Verb-first clause 1359
  - versus exclamation 1540
  - Ethical dative in — constructions 1543
  - Particles in — constructions 1543
  - Wh-* — §11.3.4 (p.1459)
  - Embedded — clauses 624
  - Meaning 1520
  - Reduced — 1542
  - Two types of —s (non-split versus pseudo-split pattern) 1528
  - XP + *dat* 'that' clause 1544
- Experiencer *See also Psychological predicate*
- Extraction from infinitival clauses 634, *See also Wh-extraction*
- Extrapolation 633, 643, 671, 877, 1234, 1272, 1282, Chapter 9
- of adverbial phrases §12.3 (p.1561)
  - of arguments §12.2 (p.1550)

- of complementives §12.2 (p.1550)
- of negative phrases 1698
- of parts of constituents *See Split Extraposition*
- of supplementives 1631
- of *te*-infinitives §5.2.2.3 (p.846)
- versus right dislocation 1609, 1785
- Mirror effect 1607, §12.5
- Remnant — §7.1.1 (p.1051), §5.2.2.3 (p.846), *See Semi-transparent te-infinitival clause*
- Split — 1279, §12.4 (p.1570)
  - Kaan's generalization 1634

## F

- Factivity 125, 624, 669, 672, 675, 687, 1525, §5.1.2.3 (p.669)
  - and adverbial modification 699
- Feature
  - Agreement — 1580
  - Case — 1580
  - Illocutionary force — 1298
  - Morphosyntactic — 1377
  - Semantic — 1377
  - Tense — 1298
- Field 1294, 1370, 1604, 1746, Chapter 9-Chapter 14
  - Clause-initial — of the clause *See Clause-initial Position*
  - Middle — of the clause *See Middle Field*
  - Postverbal — of the clause *See Postverbal Field*
- Focus
  - movement 909, 915, 1235, 1289, §13.3.2 (p.1637)
  - Contrastive — 1289, 1490, §13.3.2 (p.1637)
  - New information — 668, 1490, 1664, 1669, 1672, 1704
- Focus particle *See Focus **particle***
- Freezing 232, 703, 1285, 1288, 1674

## G

- gaan* 'to go' *See Motion/Aspectual **verb***
- + *uit* + bare infinitive 1066
- geven* 'to give' + *te*-infinitive 1054
- Goal §3.3.1.2 (p.527)

## H

- Head (Functional and Lexical —) 1255
- hebben* 'to have' 240, 344
  - + bare infinitival complement 966, 986
  - + *te*-infinitive 1054
  - versus *zijn* 'to be' 202, *See also Non-main **verb**: Perfect auxiliary selection*
- Perfect auxiliary *See Non-main **verb***

- Hesitation marker *See Pragmatic marker*
- Historical present 128
- hoe*
- Exclamative — *See Exclamative*
- Interrogative — 1538
- houden* ‘to keep’ 240
- I**
- Idiom 237, 241, 452, 556, 561, 570, 571, 572, 921, 1031, 1056, 1766
- Illocutionary force 1255
- Imperative 75, 359, §1.4.2 (p.80)
- Finite — §11.2.3 (p.1334)
- with an overt subject 96
- Subjectless — 91
- Forum — 1396
- Infinitival subjectless — 94, 97
- Participial subjectless — 98
- Quasi- — 963, 964
- Success — 86
- Inalienable possession *See Dative possessor*
- Incorporation 590, 596, 1320
- Indirect reported speech *See Direct reported speech*
- Individual-level property 241, 473, 476, 479, 486
- Infinitival clause
- Bare — 6, 72, 627, 632, 649, 662, 1452, §6.4 (p.1019), §4.4.2 (p.612)
- Subject of — *See Control, AcI-construction and Subject raising*
- Om + te-* — 6, 632, 662, 1452, §4.4.1 (p.610)
- are CPs 876
- Te-* — 6, 72, 627, 632, 652, 662, 1452, §6.3 (p.1003), §4.4.3 (p.619)
- are TPs 876
- Control — §5.2.2.1 (p.804)
- Opaque — 643, 644, 861, 868, §5.2.2.3 (p.846)
- Semi-transparent — 643, 645, 852, 868, 872, §5.2.2.3 (p.846) and §7.1.1 (p.1051)
- Subject raising — §5.2.2.2 (p.818)
- Transparent — 643, 644, §5.2.2.3 (p.846)
- Infinitive
- Modal — 76, 500, 1098
- Te-* —
- Non-verbal — 1048, *See also Modal infinitive*
- Verbal — *See Infinitival clause*
- Infinitivus-pro-participio 158, 459, 635, 642, 644, 649, 654, 852, 868, 879, 883, 901, 905, 908, 915, 948, 979, 983, 994, 1006, 1023, 1045, 1092, 1100, 1501
- does not occur in passives 983, 1013

Inflection	
Adjectival —	77
Verbal —	16, §1.3 (p.62)
Finite forms	67
Non-finite forms	71
Infinitival marker <i>te</i>	73, 633, 1310, 1325, 1328, 1330, 1336, 1340
Infinitival suffix <i>-en</i>	72
Past/passive participle (circumfix <i>ge-...-d/t</i> )	76, 1310, 1324, 1328, 1330, 1334
Present participle (suffix <i>-end</i> )	80
Verbal stem	65
Information structure	447, 542, 1489, 1793
— and the expletive <i>er</i> ‘there’	438, 1266
— and word order	1664, §13.2 (p.1608)
Inherent reflexivity	395, 475, <i>See also Inherently reflexive verb</i>
Insubordination	1545
Interjection	<i>See Pragmatic marker</i>
Intonation	1408, 1489, 1541, 1609, 1610
Inversion	
Narrative —	§11.2.4 (p.1344)
Nominative-dative —	229, 446, 1016, 1018, <i>See also NOM-DAT verb</i>
Subject-verb —	1488, <i>See also Verb-second</i>
Irrealis	<i>See Counterfactual clause</i>
Island for extraction	851, 896, 1272, 1273, 1434, 1436, 1454, 1477, 1599, 1794
— does not apply to extraposition	§12.4 (p.1570)
Adjuncts	766, 784, 1458, 1469, 1480, 1534, 1550, 1551, 1573, 1576
Complex noun phrases	765, 1458, 1469, 1531
Coordinate structures	765, 1459, 1470
Factive —	1454
Finite <i>dat</i> -clauses	713
Interrogative clauses	713, 785, 1456, 1468, 1479, 1480, 1531, 1535, 1550, 1551, 1593, 1710
<i>Om + te</i> infinitives	852, 882
Strong —	703, 1265, 1455
Subjects	1457, 1576
Weak —	697, 703, 786, 892, 1455, 1773

## J

<i>ja</i> ‘yes’	733, 1753, 1759, <i>See also polar van-construction</i>
<i>jawel</i> ‘yes’	1755
Juxtaposition	1750, 1780

## K

<i>komen</i> ‘to come’	<i>See Motion/Aspectual verb</i>
— + infinitive	1032
— + participle	1032
— + <i>te</i> -infinitive	1056

1792 *Syntax of Dutch: Verbs and verb phrases*

<i>kopen</i> ‘to buy’	296, 315, 333
<i>kosten</i> ‘to cost’	342, 1623
<i>krijgen</i> ‘to get’	236, 344, 1027
— + bare infinitival complement	969
— + <i>te</i> -infinitive	1054
Passive auxiliary	<i>See Non-main verb</i>

**L**

Last resort	1081
<i>laten</i> (Causative — ‘to make’)	354, 357, 953
Left dislocation 457, 688, 717, 748, 753, 798, 1083, 1345, 1350, 1361, 1783, §14.2 (p.1691)	
— and connectedness	1767
— versus topicalization	1498, 1774
Contrastive —	1562, §14.2 (p.1691)
Hanging-topic —	1562, §14.2 (p.1691)
Island-sensitivity of —	1773
Word order in — constructions	1759, 1761
Lexical integrity constraint	1310
Lexicalization	298
Lexicon	24, 294

**M**

<i>maken</i> ‘to make’	273, 387
Measure phrase	342, 1623
<i>men</i> ‘one’	427
<i>met</i> ‘with’	612
Comitative —PP	334, 337, 614, 1174, 1218, 1237
Middle	419, §3.2.2 (p.455)
— versus unaccusative verb	491
Adjunct —	474, 611, §3.2.2.3 (p.482)
Impersonal —	474, §3.2.2.4 (p.492)
Reflexive —	406, 475, 963, §3.2.2.5 (p.499)
Regular —	474, §3.2.2.2 (p.458)
— verb	477
Meaning	479
Resultative —	487
Middle field of the clause	10, 686, 701, 1260, 1280, Chapter 13
Mirror effect	<i>See Extraposition</i>
Modal	
— adverb	<i>See Modal adverbial</i>
— particle	141
— verb	<i>See Modal verb</i>
Infinitive —	<i>See Modal infinitive</i>

Modality	<i>See also Modal <b>verb</b> and Modal <b>adverb</b></i>
Types of —	916
Event modality	917, 923
Directed deontic	926
Dynamic/dispositional	924
Non-directed deontic	928
Propositional modality	917, 918
Epistemic	918, 1191, §1.5.2 (p.127)
Evidential	921, 1192
Modification	740
Modifier	
— of noun phrase	1279, 1314, 1635
Degree —	
Complex —	1643
Evaluative —	420, 473, 476, 482, 499, 502, 504, 508, 518, 523, 527
Mood	§1.4 (p.79)
Imperative —	<i>See Imperative</i>
Indicative	83, <i>See also Verbal <b>inflection</b></i>
Subjunctive (present and past)	101
Movement	
A- —	1377, 1577, 1579, 1672
A'- —	1376, 1577, 1579, 1582, 1690
Across-the-board —	<i>See Across-the-board movement</i>
Copy theory of —	1561
Cyclic —	785, 1441
Focus —	<i>See Focus movement</i>
General overview	§9.1 (p.1205)
Improper —	1701, 1702
Negation movement	<i>See Negation movement</i>
Object/Subject shift	<i>See Nominal argument shift</i>
Topic —	<i>See Topic movement</i>
Topicalization	<i>See Topicalization</i>
Verb —	<i>See also verb-first and Verb-second</i>
Wh- —	<i>See Wh-movement</i>
 <b>N</b>	
<i>naar ... (toe)</i> ‘towards’	549
Narrative inversion	<i>See Inversion</i>
<i>nee</i> ‘no’	733, 1753, 1759, <i>See also polar van-construction</i>
Negation	915, 1316, 1320, 1326, 1330
— and factivity	695
— movement	1287, §13.3.1 (p.1627)
Constituent —	§13.3.1 (p.1627)
Effects of — on selection restrictions	675, 678, 680, 746
Sentence —	§13.3.1 (p.1627)
Negative polarity	<i>See Negative <b>polarity</b></i>
<i>niet</i> ‘not’	733, 1185, 1756, <i>See also polar van-<b>construction</b></i>



<i>nietes</i> ‘no’	1755
<i>noemen</i> ‘to call’	<i>See Construction</i>
Nominal argument shift	306, 1167, 1505, 1577, 1581, 1701, §13.2 (p.1608)
Nominalization	384, 795, 838, 1087
— of AcI-constructions	952
BARE-INF —	75, 906, 914, 938, 958, 968, 1099
DET-INF —	75, 542
ER- —	32, 35, 201, 211, 225, 236, 241-244, 312, 317, 321, 325, 328, 330, 354, 356, 370
Noun	
Bare —	1313
Proposition —	972
Speech act —	972
Noun phrase	
Definite —	1677
Indefinite —	1677
Specific versus Non-specific —	1682
Numeral (Cardinal —)	1523
<b>O</b>	
Object	
— shift	<i>See Nominal argument shift</i>
Canonical —	197
Cognate —	197
Direct —	488, 999
Indirect —	461, §3.3.1 (p.515), <i>See also Dative</i>
Benefactive	466
Inalienable possessor	466
Periphrastic —	§3.3.1 (p.515), <i>See also Dative</i>
Recipient/goal	462
Source	465
Prepositional —	1000, 1635, 1651, §2.3 (p.284) <i>and also PO-verb</i>
— clause	1448
— of adjective	1642
— versus complementive	309
— versus VP adverbial	305
<i>om</i>	<i>See Infinitival complementizer</i>
<i>ont-</i>	365, 587
Deadjectival verb	365
Denominal verb	594
Operator	
Imperative —	1392
Question/Polarity — in <i>yes/no</i> questions	1382, 1386, 1456
Question/ <i>Wh-</i> — in <i>wh</i> -questions	1407, 1410
Topic — in topic drop constructions	1386
Order	<i>See also Word order</i>
Hierarchical — of verbs in verb clusters	1090, §7.2 (p.1062)
Linear — of verbs in verb clusters	1090, §7.3 (p.1091)

Orthography	70, 76
<i>over-</i>	
— in inherently reflexive constructions	412

**P**

Paradigmatic relation	299
Parasitic gap	1393, 1689, §11.3.7 (p.1509)
— and binding	1575, 1581, 1586, 1601
— and scrambling	1577, 1578
— and <i>wh</i> -movement	1573
— embedded in extraposed clauses	1588, 1592, 1595
— embedded in postnominal PPs	1595
— in passive constructions	1584
— in relative clauses	1573, 1577
— in topicalization constructions	1577
— in <i>wh</i> -questions	1573, 1577
— with a [ $\pm$ R] pronominal form as antecedent	1589
Accessibility hierarchy for occurrences of —s	1576
Alternation with referential personal pronoun	1578, 1584
Restrictions on —s	1574
Participle	
Past/passive —	434, 648, 1012
— versus present participle	1035
Adjectival use of —	371, 436, 493, 497
Attributive use of —	30, 203, 214, 227, 313, 318, 322, 325, 328, 330, 375, 494, 505
meaning contribution of —	1035
Predicative use of —	377, 494, 505
Verbal vs. adjectival use of —	80, 378, 435, 457
Present —	
Attributive use of —	203, 214, 227, 373, 494
Predicative use of —	375, 494
Particle	
— in finite imperatives	1396
Focus —	1187, 1229, 1242, 1356, 1491, 1711, §13.3.2 (p.1637)
Counter-presuppositional —	1712
Scalar —	1717
Verbal —	44, 251, 253, 255, 261, 984
Placement of —s	1003, 1016, 1281
Passive	314, 353, 356, 370, 388, 568, 572, 630, 637, 836, 854, 867, 928, 947, 949, 959, 961, 1446, §3.2.1 (p.407)
— auxiliary	<i>See Non-main verb</i>
— constructions in the perfect tense	1013
— Subject Raising construction	833
Adjectival —	371, 435
Constraint on passivization	430, 432, 433
Externalization of the internal argument?	434

- Geacht worden* 'was expected'-construction *See Passive Subject Raising Construction*
- Impersonal — 30, 206, 214, 228, 319, 323, 326, 329, 331, 419, 424, 701, 744, 878, 1010, §3.2.1.2 (p.420)
- Krijgen-* — 239, 419, 423, 1010, §3.2.1.4 (p.443)
- Long — construction 833
- Regular — 237, 241, 242, 243, 419, 423, 701, 744, 1010, 1273, §3.2.1.3 (p.424)
- Semi- — *See Krijgen-passive*
- Special case 960
- Worden-* — *See Regular passive*
- Perfect auxiliary *See Non-main verb*
- Pied piping 1407, 1410, 1415, 1475, 1496, 1521, 1530, 1552, 1773, 1787
- of adjective phrases 1423
- of adpositional phrases 1421
- of noun phrases 1416, 1417
- of verbal projections and clauses 1425
- Functional motivation of — 1416
- Placement
- of non-finite verbs *See Verb-final*
- of the finite verb *See Verb-first, Verb-second and Verb-final*
- Polar *van*-construction *See polar van-construction*
- Polarity (Negative —) 698, 714, 1383, 1699
- Position
- of non-finite verbs *See Verb-final*
- of the finite verb *See Verb-first, Verb-second and Verb-final*
- Argument (A) — 1462, 1561, 1574, 1579
- Non-argument (A') — 1561, 1574, 1579
- Possessor §3.3.1.4 (p.533)
- Accusative — 574
- Dative — 553
- Nominative — 238, 241, 242, 244, 573
- Possessive *bij*-phrase 553
- Possessive pronoun 553
- Possible worlds 135
- Postverbal field 10, 1259, 1270, *See also Extraposition, Chapter 9*
- PP-complement *See Prepositional object*
- PP-over-V 1274, *See also Extrapositie*
- Pragmatic marker 1746, §14.1 (p.1682)
- Discourse marker 1750, 1751
- Hesitation marker 1749, 1751
- Interjection 1749
- Salutation 1749
- Text-connective marker 1751
- Pragmatics 154, 864
- Predication (Secondary —) *See Complementary*
- Predicative complement *See Complementary*
- Prefixation 77

- Preposition  
 — stranding *See Preposition **stranding***  
 Functional — 294
- Prepositional complement *See Prepositional **object***
- Presupposition *See New-information **focus***
- proberen* ‘to try’ 655
- Pro-drop 69
- Progressive *See Aan het + infinitive + zijn **construction***  
 1255
- Projection (Extended —) *See R-pronominalization*  
 762
- Pronominal PP *See R-pronominalization*  
 762
- Pronominalization 762
- of bare infinitival 904, 925, 926, 928, 945, 957, 967, 985, 1063
- of finite clause 945
- of *te*-infinitival 849, 862, 878, 938, 986
- R- — *See R-pronominalization*
- VP- — 1074, 1084
- Pronoun *See Anticipatory pronoun*
- Anticipatory — *See Anticipatory pronoun*  
 718, 1758, 1769, 1773
- Demonstrative — 192, 604
- Non-referential — *het* ‘it’ 192, 604
- Personal —
- Reciprocal — 1767
- Referential — 710, 1767, 1769
- Definite — 1286, 1677
- Second person singular — 68
- Topicalization of — 1268, 1487
- Reflexive — 259
- complex — *zichzelf* ‘himself’ 395, 1556
- Simplex — *zich* 475, 518, 527, 1735, §2.5.2 (p.380)
- Possessive — *See also Possessor*
- Relative — 1770
- Resumptive — *See Resumptive pronoun*  
 §13.4 (p.1661)
- Weak — *See Control*
- PRO-subject *See Control*  
 523
- Prototype *See Pseudo-cleft **construction***  
 §2.5.1 (p.332)
- Pseudo-cleft construction *See Pseudo-cleft **construction***  
 §2.5.1 (p.332)
- Psychological predicate 345, 386
- Adjective 345, 386
- Causer/Cause of emotion 345, 347
- Experiencer 345, 346, *See also Experiencer*
- Noun 359, 390
- Object of emotion 347
- Subject matter of emotion 345, 346
- Target of emotion 345, 346
- Verb *See Psychological **verb***

**Q**

Quantification (Vacuous —)	1522, 1543, 1572
Quantifier	1523, 1765
Floating —	764, 1765
Question	
— formation	
— and factivity	696
Effects of — on selection restrictions	675, 678, 680, 746
<i>Wh-</i> —	1264, §11.3.1 (p.1349)
— with a <i>wh</i> -phrase <i>in situ</i>	1408
Echo —	1409
Multiple —	763, 772, 1409, 1411, §11.3.1.4 (p.1405)
—s that cannot be formulated	1420, 1425, 1450, 1454
<i>Yes/no-</i> —	1264, §11.2.1 (p.1327)
— with the finite verb in second position	1382
Quotative <i>van</i> -construction	<i>See Quotative van-construction</i>
Quoted speech	<i>See Direct reported speech</i>

**R**

<i>raken</i> ‘to get’	1027, <i>See Copular verb</i>
Recipient	§3.3.1.1 (p.516)
Reconstruction	1410, 1581, §11.3.6 (p.1493)
— and picture nouns	1564
— in relative clauses	1566
— in topicalization constructions	1557
— in <i>wh</i> -questions	1564
— of (secondary) predicates	1559
— of arguments	1557
— versus connectivity effect	1561, 1570
No — of adjunct	1560
No — of A-moved phrases	1581
No — of relative clauses embedded in arguments	1560, 1566
Referentiality	1314
Degree of —	1579
Reflexive (Weak —)	967
Relative clause	<i>See Relative clause</i>
Relativization	§11.3.2 (p.1416)
Reported speech	672, §5.1.2.4 (p.684)
Direct —	665, 708, 715, 723, 726, 1260
Indirect —	665, 708, 711, §5.1.2.4 (p.684).
Semi-direct —	709, 715, 721, 723, 726
Resumptive	
— prolepsis	1460, 1478, 1485, 1592
— pronoun	§14.2 (p.1691)
<i>dan</i> ‘then’	691
<i>dat</i> ‘that’	92, 258, 684, 688, 690, 712, 716, 718, 747
<i>zo</i> ‘thus’	716

- R-extraction 301, 509, 1274
- Right dislocation §14.3 (p.1715)
- versus extraposition 1609, 1785
- Afterthought — 1609, §14.3 (p.1715)
- Backgrounding — 1609, §14.3
- Word order in — constructions 1796
- Right Roof Constraint 1649
- R-pronominalization 299, 1427, 1428, 1589
- R-word (Weak — *er*) See *er*
- S**
- Salutation See *Pragmatic marker*
- Scope 455, 1696, 1705
- Scrambling 253, 314, 1291, 1579, 1637, Chapter 13
- of the A'-movement type 1582, §13.3 (p.1625), See also *Negation movement, Focus movement, Topic movement, and Weak proform shift*
- of the A-movement type See *Nominal argument shift*
- Second position of the clause See *Verb-second and Complementizer*
- Selection
- restrictions 756, 901
- in verb clusters 1106
- Effects of negation/question formation on — 675, 678, 680, 746
- Categorical — 27
- Semantic — 25, 870
- Semi-aspectual verb See *Non-main verb*
- Semi-direct reported speech See *Semi-direct reported speech*
- Sentence
- external phrases 10, Chapter 14
- initial position 10, 688
- Shift
- Nominal/Object/Subject — See *Nominal argument shift*
- Weak pronoun/proform — 1235, §13.4 (p.1661)
- Sluicing See *Fragment Clause*
- Source §13.3.1.3 (p.527)
- Speech See also *Reported speech*
- act
- Indirect — 1541
- versus written language 990
- Stacking 1760
- State 42, See also *Vendler's event classification*
- State of affairs 43
- Stranding 1407, 1426, 1475, 1497, 1532, 1552, 1773, 1787, See also *Preposition stranding*
- of adjective phrases 1435
- of adpositional phrases 1426
- of noun phrases 1434
- Preposition — 767, 1297, 1508, 1512, 1518, 1550, 1589

1800 *Syntax of Dutch: Verbs and verb phrases*

Structure preservation	1606
Subcategorization	24
Subject	
— Raising	<i>See Subject Raising</i>
— shift	<i>See Nominal argument shift</i>
Derived —	<i>See DO-subject and IO-subject</i>
DO- —	445
Inanimate —	430
—initial sentences	1267, 1378, 1482, 1486
IO- —	35
SUBJECT (logical —)	248, 445
Subject matter of emotion	<i>See Psychological predicate</i>
Subject Raising	639, 644, 878, 920, 930, §5.2.2.2 (p.818)
— in the formal register	869, 893
— versus control	832, 848, 875
Passive — construction	259, 833, §5.2.2.2 (p.818)
— with subject control verbs	874
Idiomatic —	872
Superiority	1090
— condition	1471
Supratemporality	122
<b>T</b>	
Target of emotion	<i>See Psychological predicate</i>
<i>te</i> (infinitival marker)	73, 633, 1310, 1325, 1328, 1330, 1336, 1340
Tense	16, 400, 710, 899, 1254, §8.2.3 (p.1156), §1.5 (p.102)
Binary — distinctions	§1.5.1 (p.103)
Finite — marking (present/past)	68, 69
Future	114, 140, 154, 1065
Future in the past	120
Future perfect	115
Future perfect in the past	120
Non-finite — marking	
Infinitives	72
Past participle	76
Present participle	80
Perfect	164, 173, 988, 1011, 1035, 1204
Past —	120
Present —	113
Reichenbach's — approach	130
Sequence of —	124, 1224
Simple past	119, 163, 165, 1204
Simple present	163, 165, 1204
Text-connective marker	<i>See Pragmatic marker</i>
Thematic role	200, 211, 224, 236
Theme (Incremental —)	584



Topic		
— drop		69, §11.2.2 (p.1329)
— movement		1290, §13.3.2 (p.1637)
— shift		1493
Aboutness —		1492
Contrastive —		1356, 1492, §13.3.2 (p.1637)
Discourse —		1664
Topicalization	254, 315, 688, 749, 798, 972, 1372, §11.3.3 (p.1422)	
— and intonation		1378, 1482, 1487, 1489
— and subject-verb inversion		1488
— in embedded clauses		1485
— of adverbial clauses		1503
— of argument clauses		1498
— of negative phrases		1698
— versus contrastive left dislocation		1498, 1774
Categorial status of the moved phrase		1481
Differences between Dutch and English topicalization		1516
Remnant —		<i>See VP-topicalization</i>
Split- —		1553
VP- —	189, 704, 916, 1082, 1275, 1504, 1506, 1513, 1559, 1676, 1787	
Bare infinitival		1510
Participle phrase		1505
<i>Te</i> -infinitival		1510
Topological field		<i>See Field</i>
<i>tot</i> (Predicative —phrase)		598
TP (Tense Phrase)	634, 762, 785, 845, 876, 879, §9.1 (p.1205)	
Transitivity		600
Truth value reversal		736
<b>U</b>		
<i>uit</i> ‘out’		
<i>gaan</i> ‘to go’ + — + bare infinitive		1066
<i>zijn</i> ‘to be’ + — + bare infinitive		1079
Unaccusativization		600
<b>V</b>		
Valency		<i>See Adicity</i>
<i>van</i>		
Polar —construction		<i>See polar van-construction</i>
Quotative —construction		<i>See Quotative van-construction</i>
<i>vanzelf</i> ‘spontaneously’		496
Vendler’s event classification		38
Binary feature analysis of —		46
Compositional aspect analysis of —		51
Extension of —		52
Hierarchical feature analysis of —		47
Participant role analysis of —		48, 56

<i>ver-</i>		365, 587
— in inherently reflexive constructions		412
Deadjectival verb		364, 595
Denominal verb		594
<i>veranderen</i> 'to change'		594
Verb		<i>Passim</i>
— alternation		<i>See Verb frame Alternation</i>
— classification		§1.2 (p.19), Chapter 2 (p.181)
Semantic —		§1.2.4 (p.54), §1.2.3 (p.36)
Vendler's Classification		<i>See Vendler's event classification</i>
Syntactic —		§1.2.2 (p.23), 1.2.4 (p.54); Chapter 2 (p.181)
— cluster		<i>See Verb cluster</i>
— -first		<i>See Verb-first</i>
— of (change of) location		538, 548, 567
— of cognition		673, 679
— of communication		673, 674
— of exchange		296, 315, 333
— of investigation/discovery		673, 681
— of saying		486
— of sound emission		278
— of wishing		673, 682
— -second		<i>See Verb-second</i>
Auxiliary —		<i>See Non-main verb</i>
Bridge —	784, 1345, 1449, 1478, 1485, 1530, 1549, 1551	
Causative/permissive —	408, 475, 519, 636, 987, §5.2.3.4 (p.918)	
Copular —	21, 471, 1008, 1025, 1037	
<i>raken</i> 'to get'		158, 442
<i>schijnen</i> 'to seem', <i>lijken</i> 'to appear', <i>blijken</i> 'to appear'		850
Deadjectival —		<i>See ver-</i>
Denominal —		<i>See be-, ont- and ver-</i>
Deverbal —		<i>See be-</i>
Ditransitive —	287, 390, 461, 478, 526, §3.3.1 (p.515), §2.1.3 (p.211)	
Factive —		786, <i>See Factivity</i>
Impersonal —		265, §2.1.1 (p.186)
Inherently reflexive —		351, 817, §2.5.2 (p.380)
Intransitive —	261, 478, 502, 512, 525, §2.1.2 (p.188)	
Irregular —		81
Latinate — in <i>-eren</i>		366, 542, 1277
Locational —		570
Main —	15, 654, 659, 850, 913, 937, 957, §1.2.1 (p.19)	
Manner of speech —		628
Measure —		342, 444, 1623
Middle —		<i>See Middle</i>

- Modal — 15, 17, 338, 456, 640, 648, 649, 659, 986, 987, 1028, *See also Modality*
- Deontic — 354, 357, 639, 830, 840, 1029, §5.2.3.2 (p.879)
- Behoren* ‘to be supposed’, *dienen* ‘must’, *hoeven* ‘need’ 871
- Moeten* ‘must’, *mogen* ‘be allowed’, *kunnen* ‘be able’, *willen* ‘want’ 105, 137, 631
- Weten* ‘to be able to’ 645
- Epistemic — §5.2.3.2 (p.879), §1.5.2 (p.129)
- kunnen* ‘can’ and *moeten* ‘must’ 135, 148, 150-151
- zullen* ‘will’ §1.5.2 (p.129)
- Evidential — 848, 850, 856, 1028
- Blijken* ‘to turn out’, *lijken* ‘to appear’, and *schijnen* ‘to seem’ 856, 923
- Dreigen* ‘to threaten’ and *beloven* ‘to promise’ 861
- Plegen* ‘to be accustomed/tend’ 645, 871
- Motion — 280, 569
- NOM-ACC — *See Psychological verb*
- NOM-DAT — 31, 290, 561, 644, 819, 1509, *See also Psychological verb*, §2.1.3 (p.211)
- Non-main — 15-7, 654-9, 850, 913, 957, Chapter 6 (p.945), §4.5 (p.624), §1.2.1 (p.19)
- Aspectual — 8, 15, 17, 154, 648, 649, 659, 982, 986, 987, §6.4.1 (p.1020)
- doen* ‘to do’ *See doen* ‘to do’ + bare infinitive
- Modal — *See Modal verb*
- Passive auxiliary 423, 469, 648, 659, 986, 1011, §6.2.2 (p.972)
- Perfect auxiliary 8, 15, 17, 648, 659, 982, 986, 1011, 1038, §6.2.1 (p.951)
- selection 30, 60, 202, 212, 226, 245, 313, 317, 322-330, 493, 504, 988
- Semi-aspectual — 8, 156, 648, 651, 659, 982, §6.3.1 (p.1003), §6.3.1 (p.1003)
- Object experiencer — *See Psychological verb*
- Particle — 236, 324, 489, 545, 546, 644, 1282, 1297, 1305, 1309, *See also Verbal particle*
- prefixed by *her-* (*[her-[in+schrijven]]*) ‘to preregister’ 1333
- with more than one particle (*[voor+[aan+melden]]*) ‘to preregister’ 1331
- Perception — 408, 481, 486, 495, 636, 673, 676, 922, 962, §5.2.3.3 (p.899)
- and accusativus-cum-infinitivo 944
- with a bare infinitival object clause 934
- with a finite object clause 934, 944
- Direct versus indirect perception 678
- Voluntary versus involuntary perception 677, 934
- Phrasal — 338
- Placement of the —
- in clause-final position *See also Verb-final*, §10.1 (p.1245)
- in first position of the clause *See also Verb-first or VP-topicalization*
- in second position of the clause *See also Verb-second*
- PO- — 525, 583, 644, 815, §2.3 (p.284)
- with a dative argument 296, 329
- Intransitive — 294, 315, 327, 457
- Problematic cases 324
- Transitive — 294
- Unaccusative — 295, 315
- Position of non-finite — *See Verb-final*
- Position of the finite — *See Verb-first, Verb-second and Verb-final*

Pseudo-intransitive —		197
Psychological —	<i>See also Psychological predicate</i> , §2.5.1 (p.332)	
Object experiencer —	350, 612, 744, 820, §2.5.1.3 (p.347)	
Causative verb		350, 363, 441
NOM-ACC verb		351, 363
NOM-DAT verb		351, 362
Periphrastic construction		386
Transitive verb		363
Reflexive —		392, 406
Subject experiencer —	349, 673, 682, §2.5.1.2 (p.338)	
Intransitive verb		352
Transitive verb		355
Unaccusative verb		357
Undative verb		359
Regular —		71
—second	<i>See Verb-second</i>	
Semelfactive —		53, 1063
Semi-aspectual —	<i>See Non-main verb</i> , <i>See Non-main verb</i>	
Semi-copular —		471, 1009, 1027
Separable/Inseparable compound —		1306
Stative —		500
Subject experiencer —	<i>See Psychological verb</i>	
Transitive —	268, 327, 477, 506, 524, 592, §2.1.3 (p.211), §2.1.2 (p.188)	
Unaccusative —	2, 274, 439, 525, 592, 854, 1447	
— versus middle verb		491
Dyadic —	<i>See NOM-DAT verb</i>	
Monadic —	30, §2.1.2 (p.188)	
—s that select <i>hebben</i> ‘to have’		210, 221, 320
—s that select <i>zijn</i> ‘to be’		221
Undative —	34, 291, 432, 817, §2.1.4 (p.228)	
Unergative —		3, 33
Weather —	<i>See Impersonal verb</i>	
Verb cluster	622, 642-6, 653-4, 852-8, 874, 901-4, 967, 983, 1501, Chapter 7 (p.1049)	
— of three verbs		991
Aux <sub>passive</sub> + V <sub>main</sub> + V <sub>main</sub>		1115
Aux <sub>perfect</sub> + Aux <sub>passive</sub> + V <sub>main</sub>		1013, 1146
Aux <sub>perfect</sub> + V <sub>main</sub> + V <sub>main</sub>		994, 1111
Aux <sub>perfect</sub> + V <sub>non-main</sub> + V <sub>main</sub>		994, 1047, 1109
Aux <sub>perfect</sub> + Aux <sub>passive</sub> + V <sub>non-main</sub>		1109
V <sub>(non-)main</sub> + Aux <sub>passive</sub> + V <sub>main</sub>		1143
V <sub>main</sub> + Aux <sub>passive</sub> + V <sub>main</sub>		1013, 1116
V <sub>main</sub> + Aux <sub>perfect</sub> + V <sub>main</sub>		992, 1111
V <sub>main</sub> + V <sub>main</sub> + V <sub>main</sub>		1125
V <sub>main</sub> + V <sub>non-main</sub> + V <sub>main</sub>		1121
V <sub>non-main</sub> + Aux <sub>passive</sub> + V <sub>non-main</sub>		1109
V <sub>non-main</sub> + V <sub>main</sub> + V <sub>main</sub>		1118
V <sub>non-main</sub> + V <sub>non-main</sub> + V <sub>main</sub>		1047, 1108

- of two verbs
  - Aux<sub>passive</sub> + V<sub>main</sub> 1012, 1107
  - Aux<sub>perfect</sub> + V<sub>main</sub> 990, 1107
  - V<sub>main</sub> + V<sub>main</sub> 1107
  - V<sub>non-main</sub> + V<sub>main</sub> 1047, 1108
- with a bare infinitive 1107, 1108, 1111, 1118, 1121, 1125, 1137, 1150, §5.2.3 (p.872)
- with a passive participle 1107, 1109, 1116, 1135, 1143, §6.2 (p.951)
- with a past participle 1107, 1111, 1134, 1141, §6.2 (p.951)
- with a *te*-infinitive 1107, 1108, 1118, 1121, 1125, 1137, 1147, §5.2.2.3 (p.846)
- Definition 888
- Hierarchical order of verbs in —s §7.2 (p.1062)
- Linear order of verbs in —s 1006, 1023, §7.3 (p.1091)
  - of three verbs 1140
    - V<sub>3</sub> + Aux<sub>2</sub> + passive participle<sub>1</sub> 1143
    - V<sub>3</sub> + Aux<sub>2</sub> + past participle<sub>1</sub> 1141
    - V<sub>3</sub> + V<sub>2</sub> + *te*-infinitive<sub>1</sub> 1147, 1150
  - of two verbs 1134
    - Aux<sub>2</sub> + passive participle<sub>1</sub> 1135
    - Aux<sub>2</sub> + past participle<sub>1</sub> 1134
    - V<sub>2</sub> + bare infinitive<sub>1</sub> 1137
    - V<sub>2</sub> + *te*-infinitive<sub>1</sub> 1137
- Permeation of — 997, 1007, 1015, 1024, 1092, 1315, 1317, 1326, 1330, 1338, 1341, §7.4 (p.1112)
- Selection restrictions in —s 1106
- Verb frame alternation 28, Chapter 3
  - with psychological predicates 347, 351, 392
  - Accusative/PP — 296, 327, §3.3.2 (p.561)
  - Anti-causativization 402
  - Causative-inchoative — *See Verb frame alternation: Causativization*
  - Causativization 51, 284, 365, 420, 491, 1050, §3.2.3 (p.510)
    - versus anti-causativization 404
  - Dative/PP — *See Dative Shift*
  - Locative —
    - Type I 421, 602, §3.3.2 (p.561)
    - Type II 421, §3.3.3 (p.579)
  - Middle formation *See Middle*
  - Nominative/PP — §3.3.3 (p.579)
  - Passivization *See Passive*
  - Transitive-oblique — 421, §3.3.2 (p.561)
- Verbal
  - collocation
    - A + V 160, 244, 286, 356, 387, 738, 1309, 1312, 1316
    - Immobile — 1306, 1316, §10.2 (p.1253)
    - Inseparable — 1306, 1307
    - Movement behavior of —s under verb-second 1303
    - N + V 78, 160, 909, 1004, 1155, 1307, 1310, 1313, 1322, 1327
    - P/particle + V *See Particle verb*

Separable —	1306, 1307
V + V	1309
— expressions	338
— root	1276, 1277
— stem	<i>See Verbal inflection</i>
Verb-final	17, 1294, §9.2 (p.1208), Chapter 10 (p.1243)
Verb-first	18, , §9.2 (p.1208), Chapter 10 (p.1243), §11.2 (p.1326)
Conjunctive	1401
Exhortative construction	1400
Finite imperative	§11.2.3 (p.1334)
Idiomatic cases	1402
Narrative inversion	§11.2.4 (p.1344)
Topic drop constructions	§11.2.2 (p.1329)
Yes/no-question	§11.2.1 (p.1327)
Verb-first/second	
— in non-main clauses?	§10.3.2 (p.1296), <i>See also Embedded Verb-second</i>
Concessive clauses	1361
Conditional clauses	1350, 1363
Contrastive clauses	1354
Exclamative clauses	1359
Teleological clauses	1365
V-first clauses introduced by a modal verb	1365
No — in main clauses?	1343
Verb-second	10, 18, 709, 1259, 1371, §9.2 (p.1208), Chapter 10 (p.1243), §11.3 (p.1347)
Embedded —	1260, 1266, 1303, 1485
Movement behaviour of X + V collocations under —	§10.2 (p.1253)
Topicalization	§11.3.3 (p.1422)
Wh-exclamatives	§11.3.4 (p.1459), <i>See also Exclamative</i>
Wh-questions	§11.3.1 (p.1349)
<i>vergeten</i> ‘to forget’	245
<i>vergeven</i> ‘to forgive’	450
<i>verkopen</i> ‘to sell’	296, 315, 333
<i>verliezen</i> ‘to lose’	245
<i>vinden</i> ‘to consider’	922, 936, <i>See also vinden-construction</i>
— + <i>te</i> -infinitive	1053
Vocative	1749
<i>voeren</i> ‘to feed’	450, 576
<i>vol</i> ‘full’	588, 596, 602
<i>voorlezen</i> ‘to read aloud to’	450

## W

wat (Exclamative —)	<i>See Exclamative</i>
<i>Wat voor</i>	
— split	207, 215, 231, 1440, 1533, 1535, 1674
Webelhuth’s paradox	1582
<i>wegen</i> ‘to weigh’	342, 1623

- wel* (Affirmative marker) 733, 1185, 1755, *See also polar van-construction*
- welles* ‘yes’ 1755
- Wh*-extraction 697, 703, 712, 1265, 1272, 1477, §11.3.1.2 (p.1384), §5.1.6 (p.756)
- from adjective phrases 1423, 1435
  - from adpositional phrases 1421, 1426
  - from noun phrases 1417, 1434
  - from verbal projections and clauses 1425
  - of subject 713
- Wh*-movement 254, 315, 1233, 1264, 1372, §11.3 (p.1347)
- in comparative (sub)deletion constructions §11.3.5 (p.1486)
  - in left-dislocation constructions 1760, 1771
  - in relative clauses §11.3.2 (p.1416)
  - in topicalization constructions §11.3.3 (p.1422)
  - in *wh*-exclamatives §11.3.4 (p.1459)
  - in *wh*-questions *See also Wh-question*, §11.3.1 (p.1349)
  - with *wh*-doubling 1451
- Long (non-local) — 1477, 1485, *See also Wh-extraction*
- from infinitival clauses 1452
  - from object clauses 1446
  - from prepositional object clauses 1448
  - from subject clauses 1446
  - of subject 1442
- Partial — 1451
- wonen* ‘to live’ 344, 516, 1248, 1623
- Word order 907
- and contrastive focus 1702
  - and contrastive topic 1702
  - and the position of the complementive 252, 1665
  - and weak pronouns/proforms §13.4 (p.1661)
  - in negative clauses §13.3.1 (p.1627)
  - in the clause Chapter 9-13; *see also verb-first, verb-second, verb-final, middle field, clause-initial position, and Extraposition*
  - in verb clusters *See Linear order*
  - of adjuncts 177, *See also Placement of adverbials*
  - of adjuncts and arguments *See Nominal argument shift*
  - of arguments 31, 229, 285, 332, 380, 388, 454, 455
  - of extraposed phrases §12.5 (p.1587)
  - restrictions on sentence-external phrases 1749, 1759, 1796
- Unmarked — in the middle field of the clause §13.1 (p.1599)
- Unmarked — of arguments 1665, 1680
- worden*
- Copular verb ‘to become’ *See Copular verb*
  - Passive auxiliary ‘to have been’ *See Non-main verb*



**Z**

<i>zelf</i> ‘himself’ (emphatic modifier)	722
<i>zich</i> (weak reflexive)	
— and Case	400
— in inherently reflexive contexts	<i>See inherently reflexive verb</i>
<i>zijn</i> ‘to be’	
— + bare infinitive	§6.4.2 (p.1029)
— + <i>te</i> -infinitive	1053
— + <i>uit</i> + bare infinitive	1079
— versus <i>hebben</i> ‘to have’	203, <i>See also Non-main verb: Perfect auxiliary selection</i>
Copular verb	<i>See Copular verb</i>
Passive auxiliary	<i>See Non-main verb</i>
Perfect auxiliary	<i>See Non-main verb</i>
<i>zullen</i> ‘will’	921, 927
Future auxiliary or epistemic modal?	140

## References (verbs and verb phrases 1-3)

- Aboh, Enoch Oladé. 2004. *The morphosyntax of complement-head sequences. Clause structure and word order patterns in Kwa*: Oxford University Press.
- Aboh, Enoch Oladé. 2007. Leftward focus versus rightward focus: the Kwa-Bantu conspiracy. *SOAS Working Papers in Linguistics* 15:81–104.
- Ackema, Peter. 1999. The non-uniform structure of Dutch N-V compounds. In *Yearbook of Morphology 1998*, eds. Geert Booij and Jaap van Marle, 127-158. Dordrecht: Kluwer.
- Ackema, Peter, and Maaïke Schoorlemmer. 1994. The middle construction and the syntax-semantics interface. *Lingua* 93:59-90.
- Ackema, Peter, and Maaïke Schoorlemmer. 1995. Middles and nonmovement. *Linguistic Inquiry* 26:173-197.
- Ackema, Peter, and Maaïke Schoorlemmer. 2006. Middles. In *The Blackwell companion to syntax, Volume III*, eds. Martin Everaert and Henk van Riemsdijk, 131-203. Malden, MA/Oxford: Blackwell Publishing.
- Aijmer, Karin. 2002. *English discourse particles. Evidence from a corpus*. Amsterdam / Philadelphia: John Benjamins.
- Alexiadou, Artemis. 2006. Left dislocation (including CLLD). In *The Blackwell companion to syntax, Volume II*, eds. Martin Everaert and Henk van Riemsdijk, 668-699. Malden, MA/Oxford: Blackwell Publishing.
- Anagnostopoulou, Elena. 2006. Clitic doubling. In *The Blackwell companion to syntax, Volume I*, eds. Martin Everaert and Henk van Riemsdijk, 519-581. Malden, MA/Oxford: Blackwell Publishing.
- Anagnostopoulou, Elena, Henk van Riemsdijk, and Frans Zwarts. 1997. *Materials on left dislocation*. Amsterdam/Philadelphia: John Benjamins.
- Baart, Joan. 1987. Focus en accent in het Nederlands. *GLOT* 2:293-312.
- Bach, Emmon, and George M. Horn. 1976. Remarks on "Conditions on Transformations". *Linguistic Inquiry* 7:265-299.
- Baker, Mark. 1988. *Incorporation. A theory of grammatical function changing*. Chicago/London: University of Chicago Press.
- Baker, Mark, Kyle Johnson, and Ian Roberts. 1989. Passive arguments raised. *Linguistic Inquiry* 20:219-251.
- Balk-Smit Duyzentkunst, Frida. 1968. Het meewerkend voorwerp, een grammaticale vergissing. *Levende Talen*:5-12.
- Baltin, Mark. 1982. A landing site theory of movement rules. *Linguistic Inquiry* 13:1-38.
- Baltin, Mark. 1983. Extraposition: bounding versus government and binding. *Linguistic Inquiry* 14:155-163.
- Baltin, Mark. 2006. Extraposition. In *The Blackwell companion to syntax, Volume II*, eds. Martin Everaert and Henk van Riemsdijk, 237-271. Malden, MA/Oxford: Blackwell Publishing.
- Barbiers, Sjef. 1995. *The syntax of interpretation*, University of Leiden/HIL: PhD thesis.

- Barbiers, Sjef. 1998. Gaps and remnants. In *Small words in the big picture. Squibs for Hans Bennis*, eds. Sjef Barbiers, Johan Rooryck and Jeroen van der Weijer. Leiden: Holland Institute of Generative Linguistics.
- Barbiers, Sjef. 1999. Intermediate landing sites. *Glott International* 4:16.
- Barbiers, Sjef. 2000. The right periphery in SOV languages: English and Dutch. In *The derivation of VO and OV*, ed. Peter Svenonius, 45-67. Amsterdam/Philadelphia: John Benjamins.
- Barbiers, Sjef. 2002. Remnant stranding and the theory of movement. In *Dimensions of movement. From features to remnants*, eds. Artemis Alexiadou, Elena Anagnostopoulou, Sjef Barbiers and Hans-Martin Gärtner, 47-67. Amsterdam/Philadelphia: John Benjamins.
- Barbiers, Sjef. 2005. Word-order variation in three-verb clusters and the division of labour between generative linguistics and sociolinguistics. In *Syntax and variation. Reconciling the biological and the social*, eds. Leonie Cornips and Karen P. Corrigan, 233-264. Amsterdam/Philadelphia: John Benjamins.
- Barbiers, Sjef. 2006. The syntax of modal auxiliaries. In *The Blackwell companion to syntax, Volume V*, eds. Martin Everaert and Henk van Riemsdijk, 1-22. Malden, Ma/Oxford: Blackwell Publishing.
- Barbiers, Sjef. 2007. On the periphery of imperative and declarative clauses in Dutch and German. In *Imperative clauses in generative grammar. Studies in honour of Frits Beukema*, ed. Wim van der Wurff, 95-112. Amsterdam/Philadelphia: John Benjamins.
- Barbiers, Sjef. 2009. Kwantitief *er en ze*. Ms. Meertens Instituut Amsterdam.
- Barbiers, Sjef. 2010. Focus particle doubling. In *Structure preserved. Studies in syntax for Jan Koster*, eds. Jan-Wouter Zwart and Mark De Vries, 21-29. Amsterdam/Philadelphia: John Benjamins.
- Barbiers, Sjef. 2013. Geography and cartography of the left periphery. The case of Dutch and German imperatives. In *Current approaches to limits and areas in dialectology*, eds. Ernestina Carrilho, Xose Alvez and Catarina Magro, 267-292. Newcastle upon Tyne: Cambridge Scholars Publishing.
- Barbiers, Sjef. 2014. Syntactic doubling and deletion as a source of variation. In *Linguistic variation in the minimalist framework*, ed. M. Carme Picallo, 197-223. Oxford: Oxford University Press.
- Barbiers, Sjef, Hans Bennis, Gunther De Vogelaer, Magda Devos, and Margreet van de Ham. 2005. *Syntactic atlas of the Dutch dialects, volume I*. Amsterdam: Amsterdam University Press.
- Barbiers, Sjef, Hans Bennis, Gunther De Vogelaer, Magda Devos, and Margreet van de Ham. 2008. *Syntactic atlas of the Dutch dialects, volume II*. Amsterdam: Amsterdam University Press.
- Barbiers, Sjef, Olaf Koenenman, and Marika Lekakou. 2010. Syntactic doubling and the structure of *wh*-chains. *Journal of Linguistics* 46:1-46.
- Barrs, Andrew. 2001. Syntactic reconstruction effects. In *The handbook of contemporary syntactic theory*, eds. Mark Baltin and Chris Collins. Malden (Mass)/Oxford: Blackwell Publishing.
- Barwise, Jon, and Robin Cooper. 1981. Generalized quantifiers and natural language. *Linguistics and Philosophy* 4:159-220.

- Bayer, Josef. 2006. *Wh-in-situ*. In *The Blackwell companion to syntax, volume V*, eds. Martin Everaert and Henk van Riemsdijk. Malden, MA/Oxford: Blackwell Publishing.
- Bech, Gunnar. 1955. *Studien über das deutsche Verbum infinitum, part 1*. Copenhagen: Ejnar Munksgard.
- Beekhuizen, Barend. 2008. *Afhankelijke V1-constructies in het Nederlands*. Ms. University of Leiden.
- Beliën, Maaïke. 2008. *Constructions, constraints and construal. Adpositions in Dutch*, Free University Amsterdam: PhD thesis.
- Beliën, Maaïke. 2012. Dutch manner of motion verbs: disentangling auxiliary selection, telicity and syntactic function. *Cognitive Linguistics* 23:1-26.
- Belletti, Adriana. 2004. Aspects of the low IP area. In *The structure of CP and IP. The cartography of syntactic structures, volume 2*, ed. Luigi Rizzi, 16-51. Oxford/New York: Oxford University Press.
- Belletti, Adriana, and Luigi Rizzi. 1988. Psych-verbs and theta-theory. *Natural Language & Linguistic Theory* 6:291-352.
- Bennis, Hans. 1977. Het kwantitatieve *er* in komparatief konstrukties. *Spektator* 6:384-387.
- Bennis, Hans. 1986. *Gaps and dummies*. Dordrecht: Foris Publications.
- Bennis, Hans. 1992. Long head movement: the position of particles in the verbal cluster in Dutch. In *Linguistics in the Netherlands 1992*, eds. Reineke Bok-Bennema and Roeland van Hout, 37-49. Amsterdam/Philadelphia: John Benjamins.
- Bennis, Hans. 1993. Morfologie bestaat niet? Over de verhouding tussen zinsbouw en woordvorming. *Tabu* 23:15-28.
- Bennis, Hans. 1995. The meaning of structure: the *wat voor* construction revisited. In *Linguistics in the Netherlands 1995*, eds. Marcel Den Dikken and Kees Hengeveld. Amsterdam/Philadelphia: John Benjamins.
- Bennis, Hans. 1998. Exclamatives! In *Linguistics in the Netherlands 1998*, eds. Renée van Bezooijen and René Kager, 27-40. Amsterdam/Philadelphia: John Benjamins.
- Bennis, Hans. 2000. *Syntaxis van het Nederlands*. Amsterdam: Amsterdam University Press.
- Bennis, Hans. 2004. Unergative adjectives and psych verbs. In *The unaccusativity puzzle: studies on the syntax-lexicon interface*, eds. Artemis Alexiadou, Elena Anagnostopoulou and Martin Everaert, 84-113. Oxford: Oxford University Press.
- Bennis, Hans. 2006. Agreement, pro, and imperatives. In *Arguments and agreement*, eds. Peter Ackema, Patrick Brandt, Maaïke Schoorlemmer and Fred Weerman, 101-123. Oxford: Oxford University Press.
- Bennis, Hans. 2007. Featuring the subject in Dutch imperatives. In *Imperative clauses in generative grammar. Studies in honour of Frits Beukema*, ed. Wim van der Wurff, 113-134. Amsterdam/Philadelphia: John Benjamins.
- Bennis, Hans, Norbert Corver, and Marcel Den Dikken. 1998. Predication in nominal phrases. *The Journal of Comparative Germanic Linguistics* 1:85-117.
- Bennis, Hans, and Teun Hoekstra. 1983. *De syntaxis van het Nederlands. Een inleiding in de regeer- en bindtheorie*. Dordrecht: Foris Publications.

- Bennis, Hans, and Teun Hoekstra. 1984. Gaps and parasitic gaps. *Linguistic Review* 4:29-87. [Reprinted as chapter 1 of Bennis (1986)].
- Bennis, Hans, and Teun Hoekstra. 1985. Een gat in de distributie van om-zinnen. *GLOT* 8:5-23.
- Bennis, Hans, and Teun Hoekstra. 1989a. PRO and the Binding Theory. In *Linguistics in the Netherlands 1989*, eds. Hans Bennis and Ans van Kemenade, 11-20. Dordrecht: Foris Publications.
- Bennis, Hans, and Teun Hoekstra. 1989b. Why Kaatje was not heard sing a song. In *Sentential complementation and the lexicon*, eds. Danny Jaspers, Wim Klooster, Yvan Putseys and Pieter Seuren, 21-40. Dordrecht: Foris Publications. Reprinted in Teun Hoekstra (2004), *Arguments and structure. Studies on the architecture of the sentence*. Berlin/New York: Mouton de Gruyter.
- Bennis, Hans, and Teun Hoekstra. 1989c. *Generatieve grammatica*. Dordrecht: Foris Publications.
- Bennis, Hans, and Pim Wehrmann. 1987. Adverbial arguments. In *Linguistics in the Netherlands 1987*, eds. Frits Beukema and Peter Coopmans, 1-11. Dordrecht: Foris Publications.
- Bhatt, Christa, and Claudia M. Schmidt. 1993. Die *am* + Infinitiv-Konstruktion im Kölnischen und im umgangssprachlichen Standarddeutschen als Aspekt-Phrasen. In *Dialektsyntax*, eds. Werner Abraham and Josef Bayer, 71-99. Opladen: Westdeutscher Verlag.
- Bianchi, Valentina. 1999. *Consequences of antisymmetry. Headed relative clauses*. Berlin/New York: Mouton de Gruyter.
- Blakemore, Diane. 2002. *Relevance and Linguistic Meaning. The semantics and pragmatics of discourse markers*. Cambridge (UK): Cambridge University Press.
- Blom, Corrien. 2005. *Complex predicates in Dutch. Synchrony and diachrony*, Free University Amsterdam: PhD thesis.
- Bobaljik, Jonathan David. 2003. Floating Quantifiers: handle with care. In *The second Glot International state-of-the-article book. The latest in Linguistics*, eds. Lisa Cheng and Rint Sybesma, 107-148. Berlin/New York: Mouton de Gruyter.
- Boeckx, Cedric. 2008. *Understanding minimalist syntax. Lessons from locality in long-distance dependencies*. Malden, MA/Oxford: Blackwell Publishing.
- Boeckx, Cedric. 2012. *Syntactic islands*. Cambridge (UK)/New York: Cambridge University Press.
- Boef, Eefje. 2013. *Doubling in relative clauses. Aspects of morphosyntactic microvariation in Dutch*, University Utrecht: PhD thesis.
- Boogaart, Ronny. 2004. 'Meet het en je weet het': van gebod naar voorwaarde. In *Taal in verandering*, eds. Saskia Daalder, Theo Janssen and Jan Noordegraaf, 23-36. Münster: Nodus Publikationen.
- Boogaart, Ronny, and Theo Janssen. 2007. Tense and aspect. In *The Oxford handbook of cognitive linguistics*, eds. Dirk Geeraerts and Hubert Cuykens, 803-828. Oxford/New York: Oxford University Press.
- Boogaart, Ronny, and Radolova Trnavac. 2004. Conditional imperatives in Dutch and Russian. In *Linguistics in the Netherlands 2004*, eds. Leonie Cornips and Jenny Doetjes, 25-35. Amsterdam/Philadelphia: John Benjamins.

- Boogaart, Ronny, and Kim Verheij. 2013. Als dát geen insubordinatie is! De pragmatiek van zelfstandige conditionele zinnen, 13-28. Amsterdam: Uitgaven Stichting Neerlandistiek VU.
- Booij, Geert. 1974. Zinsbepalingen in het Nederlands. *Spektator* 3:619-646.
- Booij, Geert. 1995. *The phonology of Dutch*. Oxford: Clarendon Press.
- Booij, Geert. 2002. *The morphology of Dutch*. Oxford/New York: Oxford University Press.
- Booij, Geert. 2010. *Construction morphology*. Oxford/New York: Oxford University Press.
- Bos, G.F. 1972. Het indirect object. *Levende talen* no. 284:7-18.
- Bouma, Gerlof J. 2008. *Starting a sentence in Dutch. A corpus study of subject- and object-fronting*, University of Groningen: PhD thesis.
- Bowers, John. 1993. The syntax of predication. *The Linguistic Review* 24:591-656.
- Branigan, Phil, and Chris Collins. 1993. Verb movement and the quotative construction in English. In *MIT Working papers in linguistics 18*, eds. Jonathan Bobaljik and Colin Phillips, 1-13. Cambridge, MA: MIT.
- Bresnan, Joan. 1972. *Theory of complementation in English syntax*, MIT: PhD thesis.
- Bresnan, Joan. 1982. Control and complementation. *Linguistic Inquiry* 13:343-434.
- Bresnan, Joan, Anna Cueni, Tatiana Nikitina, and R. Harald Baayen. 2007. Predicting the dative alternation. In *Cognitive foundations of interpretation*, eds. Gerlof Bouma, Irene Krämer and Joost Zwarts, 69-94. Amsterdam: Royal Netherlands Academy of Science.
- Broekhuis, Hans. 1987. Chain-government. *The Linguistic Review* 4:297-374. (Published in 1991).
- Broekhuis, Hans. 1992. *Chain-government: issues in Dutch syntax*, University of Amsterdam/HIL: PhD thesis.
- Broekhuis, Hans. 1997. Nogmaals Verb Projection Raising. *Tabu* 27:1-27.
- Broekhuis, Hans. 2000. Against feature strength: the case of Scandinavian object shift. *Natural Language & Linguistic Theory* 18:673-721.
- Broekhuis, Hans. 2004. Het voorzetselvoorwerp. *Nederlandse Taalkunde* 9:97-131.
- Broekhuis, Hans. 2007. Subject shift and object shift. *Journal of Comparative Germanic Linguistics* 10:109-141.
- Broekhuis, Hans. 2008. *Derivations and evaluations: object shift in the Germanic languages*. Berlin/New York: Mouton de Gruyter.
- Broekhuis, Hans. 2009a. Holmberg's Generalization: blocking and push up. In *Advances in comparative Germanic Syntax*, eds. Artemis Alexiadou, Jorge Hankamer, Thomas McFadden, Justin Nugger and Florian Schäfer, 219-245. Amsterdam/Philadelphia: John Benjamins.
- Broekhuis, Hans. 2009b. Scrambling as object shift [followed by a discussion with Guido vanden Wyngaerd]. *Nederlandse Taalkunde* 14:201-227.
- Broekhuis, Hans. 2011. A typology of clause structure. In *Linguistic Variation Yearbook 2010*, eds. Jeroen van Craenenbroeck and Johan Rooryck, 1-31. Amsterdam/Philadelphia: John Benjamins.
- Broekhuis, Hans. 2014. Feature inheritance versus extended projections. [ling.auf.net/lingbuzz/001775](http://ling.auf.net/lingbuzz/001775).
- Broekhuis, Hans, and Leonie Cornips. 1994. Undative constructions. *Linguistics* 32:173-190.



- Broekhuis, Hans, and Leonie Cornips. 1997. Inalienable possession in locational constructions. *Lingua* 101:185-209.
- Broekhuis, Hans, and Leonie Cornips. 2012. The verb *krijgen* 'to get' as an undative verb. *Linguistics* 50:1205-1249.
- Broekhuis, Hans, Leonie Cornips, and Maarten De Wind. 1996. Inalienable possession in locational constructions; some apparent problems. In *Linguistics in the Netherlands 1996*, eds. Crit Cremers and Marcel Den Dikken, 37-48. Amsterdam/Philadelphia: John Benjamins.
- Broekhuis, Hans, Hans den Besten, Kees Hoekstra, and Jean Rutten. 1995. Infinitival complementation: on remnant extraposition. *The Linguistic Review* 12:93-122.
- Broekhuis, Hans, and Claire Gronemeyer. 1997. Causative constructions: the realization of the causee. In *Linguistics in the Netherlands 1997*, eds. Jane Coerts and Helen De Hoop, 1-12. Amsterdam/Philadelphia: John Benjamins.
- Broekhuis, Hans, and Wim Klooster. 2010. Merge and Move as costly operations. *Revista Virtual de Estudos da Linguagem* 8 (special issue on Optimality Theoretic Syntax, edited by Gabriel de Avila Othero & Sergio de Moura Menuzzi):155-182. [www.revel.inf.br/](http://www.revel.inf.br/).
- Broekhuis, Hans, and Rachel Nye. 2013. Factivity and interrogative complement clauses. *Ms. Meertens Institute/University of Ghent*.
- Broekhuis, Hans, and Henk Verkuyl. 2014. Binary tense and modality. *Natural Language & Linguistic Theory* 32:973-1009.
- Büring, Daniel. 2007. Semantics, intonation, and information structure. In *The Oxford handbook of linguistic interfaces*, eds. Gillian Ramchand and Charles Reiss, 445-473. Oxford/New York: Oxford University Press.
- Burzio, Luigi. 1981. *Intransitive verbs and Italian auxiliaries*, MIT: PhD thesis.
- Burzio, Luigi. 1986. *Italian syntax: a government-binding approach*. Dordrecht/Boston/Lancaster/Tokyo: Reidel.
- Castroviejo Miró, Elena. 2006. *Wh-exclamatives in Catalan*, University of Barcelona: Doctoral Thesis.
- Castroviejo Miró, Elena. 2008. Deconstructing exclamations. *Catalan Journal of Linguistics* 7:41-90.
- Cheng, Lisa. 1997. *On the typology of wh-questions*. New York/London: Garland Publishing.
- Cheng, Lisa, and Norbert Corver. 2006. Lines of inquiry into *wh*-movement. In *Wh-movement: moving on*, eds. Lisa Cheng and Norbert Corver. Cambridge, MA/London: MIT Press.
- Cheng, Lisa, and Rint Sybesma. 2000. *The first "Glot International" state-of-the-article book: the latest in linguistics*. Berlin: Mouton de Gruyter.
- Chierchia, Gennaro, and Sally McConnell-Ginet. 1992. *An introduction to semantics*. Cambridge/London: MIT Press.
- Chomsky, Noam. 1964. *Current issues in linguistic theory*. The Hague,: Mouton.
- Chomsky, Noam. 1965. *Aspects of the theory of syntax*. Cambridge, MA: MIT Press.
- Chomsky, Noam. 1973. Conditions on transformations. In *A festschrift for Morris Halle*, eds. Stephen Anderson and Paul Kiparsky, 71-132. New York: Holt, Rinehart, and Winston.
- Chomsky, Noam. 1977. On *wh*-movement. In *Formal syntax*, eds. Peter W. Culicover, Thomas Wasow and Adrian Akmajian, 71-132. New York: Academic Press.



- Chomsky, Noam. 1981. *Lectures on government and binding*. Dordrecht: Foris Publications.
- Chomsky, Noam. 1986. *Barriers*. Cambridge, Mass.: MIT Press.
- Chomsky, Noam. 1991. Some notes on economy of derivation and representation. In *Principles and parameters in comparative syntax*, ed. Robert Freidin, 417-454. Cambridge, MA: MIT Press.
- Chomsky, Noam. 1995. *The minimalist program*. Cambridge, MA: MIT Press.
- Chomsky, Noam. 2008. On phases. In *Foundational Issues in Linguistic Theory. Essays in Honor of Jean-Roger Vergnaud*, eds. Robert Freidin, Carlos P. Otero and Maria Luisa Zubizarreta, 133-166. Cambridge, MA/Oxford: MIT Press.
- Chomsky, Noam, and Howard Lasnik. 1977. Filters and control. *Linguistic Inquiry* 8:425-504.
- Christensen, Ken Ramshøj. 2005. *Interfaces. Negation – syntax – brain*, University of Aarhus: PhD thesis.
- Cinque, Guglielmo. 1990. *Types of A'-dependencies*. Cambridge, MA/London: MIT Press.
- Cinque, Guglielmo. 1993. A null theory of phrase and compound stress. *Linguistic Inquiry* 24:239-297.
- Cinque, Guglielmo. 1999. *Adverbs and functional heads: a cross-linguistic perspective*. New York/Oxford: Oxford University Press.
- Cinque, Guglielmo. 2003. Issues in adverbial syntax. *Lingua* 114:638-710.
- Cinque, Guglielmo. 2006. Complement and Adverbial PPs: Implications for Clause Structure. In *Restructuring and Functional Heads*, 145-166. Oxford/New York: Oxford University Press.
- Colleman, Timothy. 2006. *De Nederlandse datiefalternantie. Een constructioneel en corpusgebaseerd onderzoek*, Ghent University: PhD thesis.
- Colleman, Timothy, and Martine Delorge. 2010. Inhoudsobjecten, partnerobjecten en de dubbel-voorzetselobject-constructie. In *Artikelen voor Magda Devos bij haar afscheid van de Universiteit Gent*, eds. Johan De Caluwe and Jacques van Keymeulen, 111-126. Gent: Academia Press.
- Collins, Chris, and Phil Branigan. 1997. Quotative inversion. *Natural Language & Linguistic Theory* 15:1-41.
- Comrie, Bernard. 1985. *Tense*. Cambridge: Cambridge University Press.
- Contreras, Heles. 1984. A Note on Parasitic gaps. *Linguistic Inquiry* 15:698-701.
- Coopmans, Peter. 1985. *Languages types: continua or parameters?*, University of Utrecht: PhD thesis.
- Coppen, Peter-Arno. 1991. *Specifying the noun phrase*. Amsterdam: Thesis Publishers.
- Coppen, Peter-Arno. 1998. De succes-imperatief. *Nederlandse Taalkunde* 2:85-95.
- Coppen, Peter-Arno. 2013. De zin die wij merken dat ook voor linguïstische problemen zorgt. *Nederlandse Taalkunde* 18:193-203.
- Coppen, Peter-Arno, and Maarten Klein. 1992. Het einde van Verb Raising. In *Nieuwe eskapades in de Neerlandistiek. Opstellen van vrienden voor M.C. van den Toorn bij zijn afscheid als hoogleraar Nederlandse Taalkunde aan de Katholieke Universteit Nijmegen*, ed. Maarten Klein, 32-46. Groningen: Wolters-Noordhoff.

- Cornips, Leonie. 1991. Possessive object constructions in Heerlens. In *Linguistics in the Netherlands 1983*, eds. Frank Drijkoningen and Ans van Kemenade, 21-30. Amsterdam/Philadelphia: John Benjamins.
- Cornips, Leonie. 1994. De hardnekkige vooroordelen over de regionale *doen*+infinitief-constructie. *Forum der Letteren* 35:282-294.
- Cornips, Leonie. 1994. *Syntactische variatie in het Algemeen Nederlands van Heerlen*, University of Amsterdam: PhD thesis.
- Cornips, Leonie. 1996. The spread of the reflexive adjunct middle in the Limburg dialects: 1885 -1994. In *Linguistics in the Netherlands 1996*, eds. Crit Cremers and Marcel Den Dikken, 49 -60. Amsterdam: John Benjamins.
- Cornips, Leonie. 1998. Habitual *doen* in Heerlen Dutch. In *Do in English, Dutch and German. History and present-day variation*, eds. Ingrid Tieken-Boon van Ostade, Marijke van der Wal and Arjan van Leuvensteijn, 82-101. Münster: Nodus Publikationen.
- Cornips, Leonie. 2006. Intermediate syntactic variants in a dialect - standard speech repertoire and relative acceptability. In *Gradience in grammar. Generative perspectives* eds. Gisbert Fanselow, Caroline Féry, Matthias Schlesewsky and Ralf Vogel, 85-105. Oxford: Oxford University Press.
- Cornips, Leonie, and Aafke Hulk. 1996. Ergative reflexives in Heerlen Dutch and French. *Studia Linguistica* 50:1-21.
- Corver, Norbert. 1990. *The syntax of left branch extraction*, University of Tilburg: PhD thesis.
- Corver, Norbert. 1991. Extrapositie. In *Grammatische analyse: syntactische verschijnselen van het Nederlands en Engels*, ed. Jan Model. Dordrecht: ICG Publications.
- Corver, Norbert. 1992. "Bij Marie in de nek": interne structuur en extractiegedrag. *Gramma/TTT*:21-40.
- Corver, Norbert. 1994. Parenthetical clauses. Their nature and distribution. Tilburg: Handout staff seminar Grammaticamodellen.
- Corver, Norbert. 1995. Succes-imperatieven, Evidentie voor de transitiviteit van niet-ergativen. *Tabu* 25:125-127.
- Corver, Norbert. 2003. Hoe leefbaar is het Nederlands. *Nederlandse Taalkunde* 8:285-300.
- Corver, Norbert. 2006. Comparative deletion and subdeletion. In *The Blackwell companion to syntax, Volume I*, eds. Martin Everaert and Henk van Riemsdijk. Malden, MA/Oxford: Blackwell Publishing.
- Corver, Norbert. 2006. Freezing effects. In *The Blackwell companion to syntax, Volume II*, eds. Martin Everaert and Henk van Riemsdijk. Malden, Mass/Oxford: Blackwell Publishing.
- Corver, Norbert, and Winfried Lechner. In prep. Comparative deletion and subdeletion. In *The Blackwell companion to syntax [2nd, revised edition]*, eds. Martin Everaert and Henk van Riemsdijk. Malden, MA/Oxford: Blackwell Publishing.
- Corver, Norbert, and Craig Thiersch. 2003. Remarks on parentheticals. In *Germania et alia: A linguistic webschrift for Hans den Besten*, eds. Jan Koster and Henk van Riemsdijk.

- Corver, Norbert, and Henk van Riemsdijk. 1994. *Studies on scrambling: movement and non-movement approaches to free word-order phenomena*. Berlin/New York: Mouton de Gruyter.
- Coussé, Evie. 2008. *Motivaties voor volgordevariatie. Een diachrone studie van werkwoordsvolgorde in het Nederlands*, University of Ghent: PhD thesis.
- Coussé, Evie, and Albert Oosterhof. 2012. Het imperativische participium in het Nederlands. Vorm, betekenis en gebruik. *Nederlandse Taalkunde* 17:26-55.
- Cremers, Crit. 1980. Over nominale en verbale tijd (deel I). *Tabu* 11:32-49.
- Cremers, Crit. 1983. On two types of infinitival complementation. In *Linguistic Categories: auxiliaries and related puzzles*, Vol. 1, eds. Frank Heny and Barry Richards, 169-221. Dordrecht: Reidel.
- Crystal, David. 1991. *A dictionary of linguistics and phonetics (third edition)*: Blackwell Publisher.
- Culicover, Peter W. 2001. Parasitic gaps: a history. In *Parasitic gaps*, eds. Peter. W. Culicover and Paul M. Postal, 3-68. Cambridge (MA.)/London: MIT Press.
- Culicover, Peter. W., and Paul M. Postal. 2001. *Parasitic gaps*. Cambridge (MA.)/London: MIT Press.
- Daalder, Saskia, and Aleid Blom. 1976. De structurele positie van reflexieve en reciproke pronomina. *Spektator* 5:397-414.
- Dayal, Veneeta. 2006. Multiple-*wh*-questions. In *The Blackwell companion to syntax, Volume III*, eds. Martin Everaert and Henk van Riemsdijk, 275-326. Malden, MA/Oxford: Blackwell Publishing.
- De Geest, Wim. 1972. *Complementaire constructies bij verba sentiendi in het Nederlands*. Gent: Higo.
- De Groot, Casper. 2000. The absentive. In *Tense and aspect in the languages of Europe*, ed. Östen Dahl, 693-719. Berlin/New York: Mouton de Gruyter.
- De Haan, Ger. 1974. On extraposition. *Spektator* 4:161-183.
- De Haan, Ger. 1979. *Conditions on rules*. Dordrecht: Foris Publications.
- De Haan, Germen J. 2010. *Studies in West Frisian Grammar. Selected papers edited by Jarich Hoekstra, Willem Visser and Goffe Jensma*. Amsterdam/Philadelphia: John Benjamins.
- De Haas, Wim, and Mieke Trommelen. 1993. *Morfologisch handboek van het Nederlands: een overzicht van de woordvorming*. 's-Gravenhage: SDU Uitgeverij.
- De Hoop, Helen. 1992. *Case configuration and noun phrase interpretation*, University of Groningen: PhD thesis.
- De Hoop, Helen, and Wim Kosmeijer. 1995. Case and scrambling: D-structure versus S-structure. In *Studies in comparative Germanic syntax*, eds. Hubert Haider, Susan Olsen and Sten Vikner, 139-158. Dordrecht/Boston/London: Kluwer Academic Publishers.
- De Rooij, Jaap. 1986. *Wezen en zijn*. *Tabu* 8:295-309.
- De Saussure, Ferdinand. 1916. *Course in general linguistics*. London: Duckworth.
- De Schutter, Georges. 1974. *De Nederlandse zin. Poging tot beschrijving van zijn structuur*. Brugge: De Tempel.
- De Schutter, Georges. 1974. *Wezen vissen*. Dialectgeografie van een constructie. *Taal & Tongval* 26:70-85.

- De Schutter, Georges. 1976. De bouw van de Nederlandse zin: beschrijving en voorstel tot beregeling. *Verslagen & Mededelingen van de Koninklijke Academie voor Nederlandse Taal- en Letterkunde* 86:165-282.
- De Sutter, Gert. 2005. *Rood, groen, corpus! Een taalgebruikersgebaseerde analyse van woordvolgordevariatie in tweeledige werkwoordelijke eindgroepen*, University of Leuven: PhD thesis.
- De Sutter, Gert. 2007. Naar een corpusgebaseerde, cognitief-functionele verklaring van de woordvolgordevariatie in tweeledige werkwoordelijke eindgroepen. *Nederlandse Taalkunde* 12:302-330.
- De Vries, Jelle. 2001. *Onze Nederlandse spreektaal*. Den Haag: Sdu Uitgevers.
- De Vries, Mark. 1999. Extraposition of relative clauses as specifying coordination. In *Proceedings of ConSole VII*, eds. Tina Cambier-Langeveld, Anikó Lipták, Michael Redford and Eric Jan van der Torre, 293-309. Leiden: SOLE.
- De Vries, Mark. 2002. *The syntax of relativization*, University of Amsterdam: PhD thesis.
- De Vries, Mark. 2006. Reported direct speech in Dutch. In *Linguistics in the Netherlands 2006*, eds. Jeroen van de Weyer and Bettelou Los, 212-223. Amsterdam/Philadelphia: John Benjamins.
- De Vries, Mark. 2009. The right and left periphery in Dutch. *The Linguistic Review* 26:291-327.
- De Vries, Mark. 2011a. Extrapositie. *Nederlandse Taalkunde* 16:273-295.
- De Vries, Mark. 2011b. Extrapositie: een reactie op Vanden Wyngaerd. *Nederlandse Taalkunde* 16:301-303.
- De Vries, Mark. 2014. Across-the-Board Phenomena. Ms. University of Groningen.
- De Vries, Mark, and Dennis Ott. 2012. Thinking in the right direction: an ellipsis analysis of right-dislocation. *Linguistics in the Netherlands* 29:123-133.
- De Wit, Petra. 1997. *Genitive case and genitive constructions*, University of Utrecht: PhD thesis.
- Degand, Liesbeth. 2011. Connectieven in de rechterperiferie. Een contrastieve analyse van *dus* en *donc* in gesproken taal. *Nederlandse Taalkunde* 16:333-348.
- Degand, Liesbeth, Bert Cornillie, and Paola Pietrandrea (eds). 2013. *Discourse Markers and Modal Particles. Categorization and description*. Amsterdam/Philadelphia: John Benjamins.
- Dekkers, Joost. 1999. *Derivations & evaluations. On the syntax of subjects and complementizers*, University of Amsterdam/HIL: PhD thesis.
- Delfitto, Denis. 2006. Adverb classes and adverb placement. In *The Blackwell companion to syntax, Volume I*, eds. Martin Everaert and Henk van Riemsdijk, 83-120. Malden (MA)/Oxford (UK): Blackwell Publishing.
- Delfitto, Denis, and Norbert Corver. 1998. Feature Primitives and the Syntax of Specificity. *Italian Journal of Linguistics* 10:281-334.
- Den Besten, Hans. 1978. On the presence and absence of *wh*-elements in Dutch comparatives. *Linguistic Inquiry* 9:641-671. Reprinted in Den Besten (1989), *Studies in West Germanic syntax*. Amsterdam: Rodopi.
- Den Besten, Hans. 1981. A case filter for passives. In *Theory of markedness in generative grammar. Proceedings of the 1979 GLOW Conference*, eds. Adriana Belletti, Luciana Brandi and Luigi Rizzi, 65-122. Pisa: Scuola

- Normale Superiore. Reprinted in Den Besten (1989), *Studies in West Germanic syntax*. Amsterdam: Rodopi.
- Den Besten, Hans. 1983. On the interaction of root transformations and lexical deletive rules. In *On the formal nature of the Westgermania*, ed. Werner Abraham, 47–131. Amsterdam: Benjamins. Reprinted in Den Besten (1989), *Studies in West Germanic syntax*. Amsterdam: Rodopi.
- Den Besten, Hans. 1985. The ergative hypothesis and free word order in Dutch and German. In *Studies in German Grammar*, ed. Jindřich Toman, 23-65. Dordrecht/Cinnaminson: Foris Publications. Reprinted in Den Besten (1989), *Studies in West Germanic syntax*. Amsterdam: Rodopi.
- Den Besten, Hans. 1985. Some remarks on the ergative hypothesis. *Groninger Arbeiten zur germanistischen Linguistik* 21:61-81.
- Den Besten, Hans, and Hans Broekhuis. 1989. Woordvolgorde in de werkwoordelijke eindreeks. *GLoT* 12:79-137.
- Den Besten, Hans, and Hans Broekhuis. 1992. Verb Projection Raising in het Nederlands. *Spektator* 21:21-34.
- Den Besten, Hans, and Jerold E. Edmondson. 1983. The verbal complex in continental West Germanic. In *On the formal syntax of Westgermania. Papers from the "3rd Groninger Grammar Talks", January 1981*, ed. Werner Abraham, 155-216. Amsterdam/Philadelphia: John Benjamins.
- Den Besten, Hans, and Jean Rutten. 1989. On verb raising and free word order in Dutch. In *Sentential complementation and the lexicon*, eds. Dany Jaspers, Wim Klooster, Yvan Putseys and Pieter Seuren, 41-56. Dordrecht/Providence: Foris Publications.
- Den Besten, Hans, Jean Rutten, Tonjes Veenstra, and Joop Veld. 1988. Verb raising, extraposition and de derde constructie. Ms. University of Amsterdam, Dept. of General Linguistics.
- Den Besten, Hans, and Gert Webelhuth. 1987. Remnant topicalization and the constituent structure of VP in the Germanic SOV languages. *GLOW Newsletter* 18:15-16.
- Den Besten, Hans, and Gert Webelhuth. 1990. Stranding. In *Scrambling and barriers*, eds. Günther Grewendorf and Wolfgang Sternefeld, 77-92. Amsterdam/Philadelphia: John Benjamins.
- Den Dikken, Marcel. 1992. Empty operator movement in Dutch imperatives. In *Language and Cognition* 2, eds. Dicky Gilbers and Sietze Looyenga, 51-64.
- Den Dikken, Marcel. 1995. Binding, expletives and levels. *Linguistic Inquiry* 26:347-354.
- Den Dikken, Marcel. 1995. *Particles: on the syntax of verb-particle, triadic, and causative constructions*. New York/Oxford: Oxford University Press.
- Den Dikken, Marcel. 2003. Comparative correlatives and verb second. In *Germania et alia. A Linguistic website for Hans den Besten*, eds. Jan Koster and Henk van Riemsdijk.
- Den Dikken, Marcel. 2003. When particle don't part. Ms., *Unpublished manuscript CUNY*. New York.
- Den Dikken, Marcel. 2005. Comparative correlatives comparatively. *Linguistic Inquiry* 36:497-532.

- Den Dikken, Marcel. 2006. *Relators and linkers. The syntax of predication, predicate inversion, and copulas*. Cambridge, MA/London: MIT Press.
- Den Dikken, Marcel, and Alma Næss. 1993. Case dependencies: the case of predicate inversion. *The Linguistic Review* 10:303-336.
- Den Hertog, C.H. 1973. *Nederlandse spraakkunst, eerste stuk: de leer van de enkelvoudige zin*. Vierde druk, Ingeleid en bewerkt door H.Hulshof. Amsterdam: Versluys.
- Den Hertog, C.H. 1973. *Nederlandse spraakkunst, tweede stuk: de leer van de samengestelde zin*. Derde druk, Ingeleid en bewerkt door H.Hulshof. Amsterdam: Versluys.
- Déprez, Viviane. 1989. *On the typology of syntactic positions and the nature of chains: Move-Alpha to the specifier of functional projections*, MIT: PhD thesis.
- Di Sciullo, Anna-Maria, and Edwin Williams. 1987. *On the definition of the word*. Cambridge, MA: MIT Press.
- Diepeveen, Ariane. 2012. *Modifying words. Dutch adverbial morphology in contrast*, Freien Universität Berlin: PhD thesis.
- Diesing, Molly. 1992. *Indefinites*. Cambridge, MA: MIT Press.
- Diewald, Gabriele. 2009. "Same same but different" – Modal particles, discourse markers and the art (and purpose) of categorization. In *Discourse Markers and Modal Particles. Categorization and description*, eds. Liesbeth Degand, Bert Cornillie and Paola Pietrandrea, 19-45. Amsterdam / Philadelphia: John Benjamins.
- Dik, Simon C. 1978. *Functional grammar*. Dordrecht: Foris Publications.
- Dik, Simon C. 1980. *Studies in functional grammar*. London/New York: Academic Press.
- Dik, Simon C. 1985. Infinitief-konstrukties met *om* in een functionele grammatika. *Glott* 8:25-46.
- Dik, Simon C. 1997. *The theory of functional grammar, Part 1: the structure of the clause*: Mouton de Gruyter.
- Dobrovie-Sorin, Carmen 2006. The *se*-anaphor and its role in argument realization. In *The Blackwell companion to syntax, Volume IV*, eds. Martin Everaert and Henk van Riemsdijk. Malden, Ma/Oxford: Blackwell Publishing.
- Doetjes, Jenny. 1997. *Quantifiers and selection: on the distribution of quantifying expressions in French, Dutch and English*, University of Leiden: PhD thesis.
- Dowty, David. 1979. Toward a semantic analysis of verb aspect and the English imperfective progressive. *Language and Philosophy* 1:45-77.
- Dowty, David. 1979. *Word meaning in Montague grammar. The semantics of verbs and times in Generative Semantics and in Montague's PTQ*. Dordrecht: Reidel.
- Drosdowski, Günter. 1995. *DUDEN Grammatik der deutschen Gegenwartssprache*. Mannheim/Wien/Zürich: Dudenverlag.
- Droste, F.G. 1958. Het temporele stelsel in het Nederlands. *Nieuwe Taalgids* 51:305-312.
- Droste, F.G. 1972. Vragen met *he*. *Leuvense Bijdragen* 61:121-133.
- Dubinsky, Stanley W., and William D. Davies. 2005. Control and raising. In *The encyclopedia of language & linguistics*, ed. Keith Brown, 131-139. Oxford: Elsevier.



- Duinhoven, A.M. 1984. *Ban de bom!* Over vorm en betekenis van de imperatief. *De Nieuwe Taalgids* 77:148-156.
- Duinhoven, A.M. 1985. De deelwoorden vroeger en nu. *Voortgang* 6:97-138.
- Duinhoven, A.M. 1989. Het voorzetselvoorwerp. Een zinspatroon in wording. *De Nieuwe Taalgids* 82:40-45.
- Duinhoven, A.M. 1997. *Middel-Nederlandse syntaxis: synchroon en diachroon 2. De werkwoordgroep*. Groningen: Martinus Nijhoff.
- É. Kiss, Katalin. 2002. *The syntax of Hungarian*. Cambridge (UK): Cambridge University Press.
- Elliott, Dale E. 1974. Towards a grammar of exclamations. *Foundation of Language* 11:231-246.
- Emonds, Joseph. 1972. Evidence that indirect object movement is a structure preserving rule. *Foundations of Language* 8:546-561.
- Emonds, Joseph. 1976. *A transformational approach to English syntax: root, structure-preserving, and local transformations*. New York: Academic Press.
- Emonds, Joseph E. 1985. *A unified theory of syntactic categories*. Dordrecht/Cinnaminson: Foris Publications.
- Engdahl, Elisabet. 1983. Parasitic gaps. *Linguistics and philosophy* 6:5-34. [Cited from the reprinted version in Peter. W. Cullicover & Paul M Postal (2001)].
- Erb, Marie Christine. 2001. *Finite auxiliaries in German*, University of Tilburg: PhD thesis.
- Ernst, Thomas. 2002. *The syntax of adjuncts*. Cambridge (UK)/New York: Cambridge University Press.
- Erteschik-Shir, Nomi. 1973. *On the nature of island constraints*, MIT: PhD thesis.
- Erteschik-Shir, Nomi. 2006. Bridge phenomena. In *The Blackwell companion to syntax, Volume I*, eds. Martin Everaert and Henk van Riemsdijk, 284-294. Malden, MA/Oxford: Blackwell Publishing.
- Erteschik-Shir, Nomi. 2007. *Information structure. The syntax-discourse interface*. Oxford/New York: Oxford University press.
- Evans, Nicholas. 2007. Insubordination and its uses. In *Finiteness. Theoretical and empirical foundations*, ed. Irina Nikolaeva, 366-431. Oxford: Oxford University Press.
- Everaert, Martin. 1982. A syntactic passive in Dutch. *Utrecht Working Papers in Linguistics* 11:37-73.
- Everaert, Martin. 1984. Inherently reflexive verbs and the empty category principle. In *Van periferie naar kern*, eds. Ger de Haan, Mieke Trommelen and Wim Zonneveld, 63-71. Dordrecht/Cinnaminson: Foris Publications.
- Everaert, Martin. 1986. *The syntax of reflexivization*. Dordrecht/Riverton: Foris Publications.
- Everaert, Martin. 1990. NP-movement 'across' secondary objects. In *Grammar in progress*, eds. Joan Mascaró and Marina Nespó, 125-136. Dordrecht: Foris Publications.
- Everaert, Martin. 1991. Infinitiefzinnen. In *Grammatische analyse: syntactische verschijnselen van het Nederlands en Engels*, ed. Jan Model. Dordrecht: ICG Publications.
- Evers-Vermeul, Jacqueline. 2005. *The development of Dutch connectives*, University of Utrecht: PhD Thesis.



- Evers-Vermeul, Jacqueline. 2010. *Dus* vooraan of in het midden? Over vorm-functierelaties in het gebruik van connectieven. *Nederlandse Taalkunde*:149-175.
- Evers, Arnold. 1975. *The transformational cycle in Dutch and German*, University of Utrecht: PhD thesis.
- Fagan, Sarah. 1988. The English middle. *Linguistic Inquiry* 19:181-203.
- Fagan, Sarah. 1992. *The syntax and semantics of middle constructions. A study with special reference to German*. Cambridge: Cambridge University Press.
- Fanselow, Gisbert. 2002. Against remnant VP-movement. In *Dimensions of movement. From features to remnants*, eds. Artemis Alexiadou, Elena Anagnostopoulou, Sjeff Barbiers and Hans-Martin Gaertner, 91-125. Amsterdam/Philadelphia: John Benjamins.
- Fiengo, Robert, and James Higginbotham. 1981. Opacity in NP. *Linguistic Analysis* 7:395-421.
- Florijn, Arjen. 1992. *Beregeling van Nederlandse woordvolgorde*, University of Amsterdam: PhD thesis.
- Foolen, Ad. 1993. *De betekenis van partikels. Een documentatie van de stand van het onderzoek, met bijzondere aandacht voor maar*, Katholieke Universiteit Nijmegen: PhD thesis.
- Foolen, Ad, Ingrid van Alphen, Eric Hoekstra, Henk Lammers, Harrie Mazeland, and Esther Pascual. 2006. Het quotatieve *van*. *Toegepaste Taalwetenschap in Artikelen* 76:137-149.
- Foolen, Ad, and Ton Van der Wouden. 2011. Pragmatische partikels in de rechterperiferie. *Nederlandse Taalkunde* 16:307-322.
- Frey, Werner. 2006. Contrast and movement to the German prefield. In *The Architecture of Focus*, eds. Valéria Molnár and Susanne Winkler, 235–264. Berlin: Mouton de Gruyter.
- Geerts, Guido. 1984. *Algemene Nederlandse spraakkunst* Groningen: Wolters-Noordhoff.
- Gerritsen, Marinel. 1991. *Atlas van de Nederlandse dialecten (AND). deel I*. Amsterdam: Meertens Institute.
- Green, Georgia M. 1974. *Semantics and syntactic regularity*. Bloomington: Indiana University Press.
- Grewendorf, Günther, and Wolfgang Sternefeld (eds). 1990. *Scrambling and barriers*. Amsterdam: Benjamins.
- Grice, H.P. 1975. Logic and conversation. In *Speech acts: Syntax and Semantics 3*, eds. P. Cole and J. Morgan, 41-58. New York: Academic Press.
- Grice, H.P. 1989. *Studies in the ways of words*. Cambridge, MA: Harvard University Press.
- Grimshaw, Jane. 1979. Complement selection and the lexicon. *Linguistic Inquiry* 10:279-326.
- Grimshaw, Jane. 1990. *Argument structure*. Cambridge, MA: MIT Press.
- Grimshaw, Jane. 1991. Extended projections. Ms. Brandeis University, Waltham, MA.
- Grimshaw, Jane. 2012. Last Resorts: a typology of *do*-support. In *Linguistic derivations and filtering. Minimalism and optimality theory*, eds. Hans Broekhuis and Ralf Vogel. Sheffield (UK)/Bristol (US): Equinox Publishing.

- Groenendijk, Jeroen, and Martin Stokhof. 1984. *Studies on the semantics of questions and the pragmatics of answers*, University of Amsterdam: PhD thesis.
- Grohmann, Kleanthes K. 2003. *Prolific Domains. On the Anti-Locality of Movement Dependencies*. Amsterdam/Philadelphia: John Benjamins.
- Gropen, Jess, Steven Pinker, Michelle Hollander, Richard Goldberg, and Ronald Wilson. 1989. The learnability and acquisition of the dative alternation in English. *Language* 65:203-257.
- Guéron, Jacqueline. 1980. On the syntax and semantics of PP extraposition. *Linguistic Inquiry* 11:637-678.
- Gussenhoven, Carlos. 1992. Sentence accents and argument structure. In *Thematic structure. Its role in grammar*, ed. I.M. Roca, 79-106. Berlin/New York: Foris Publications.
- Haan, Judith. 2002. *Speaking of questions. An exploration of Dutch question intonation*, University of Nijmegen: PhD Thesis.
- Haan, Judith, and Vincent J. van Heuven. 2003. This is a yes/no-question? In *Linguistics in the Netherlands 2003*, eds. Leonie Cornips and Paula Fikkert. Amsterdam/Philadelphia: John Benjamins.
- Haerberli, Eric. 2002. *Features, categories and the syntax of A-positions*. Dordrecht/Boston/London: Kluwer.
- Haegeman, Liliane. 1990. Non-overt subjects in diary contexts. In *Grammar in progress. GLOW essays for Henk van Riemsdijk*, eds. Joan Mascaró and Marina Nespore, 167-174. Dordrecht/Providence: Foris Publications.
- Haegeman, Liliane. 1991. Scrambling, clitic placement and Agr recursion in West Flemish. Ms. University of Geneva.
- Haegeman, Liliane. 1992. *Theory and description in generative syntax: a case study in West Flemish*. Cambridge: Cambridge University Press.
- Haegeman, Liliane. 1993a. The morphology and distribution of object clitics in West Flemish. *Studia Linguistica* 47:57-94.
- Haegeman, Liliane. 1993b. Some speculations on argument shift, clitics and crossing in West-Flemish. In *Dialektsyntax (Linguistische Berichte Sonderheft 6)*, eds. Werner Abraham and Josef Bayer, 131-160. Opladen: Westdeutscher Verlag.
- Haegeman, Liliane. 1994. *Introduction to government and binding theory. 2<sup>nd</sup> edition*. Oxford/Cambridge (Mass.): Blackwell.
- Haegeman, Liliane. 1995. *The syntax of negation*. Cambridge: Cambridge University Press.
- Haegeman, Liliane. 2006. Clitic climbing and the dual status of *sembrare*. *Linguistic Inquiry* 37:484-501.
- Haegeman, Liliane, and Henk van Riemsdijk. 1986. Verb projection raising, scope, and the typology of rules affecting verbs. *Linguistic Inquiry* 17:417-466.
- Haegeman, Liliane, and Raffaella Zanuttini. 1991. Negative heads and the negative criterion. *The Linguistic Review* 8:233-251.
- Haeseryn, Walter. 1990. *Syntactische normen in het Nederlands. Een empirisch onderzoek naar woordvolgordevariatie in de werkwoordelijke eindgroep*, University of Nijmegen: PhD Thesis.
- Haeseryn, Walter, Kirsten Romijn, Guido Geerts, Jaap de Rooij, and Maarten C. van den Toorn. 1997. *Algemene Nederlandse spraakkunst*. Groningen: Nijhoff.

- Haider, Hubert. 1985. V-second in German. In *Verb second phenomena in Germanic languages*, eds. Hubert Haider and Martin Prinzhorn, 49-75. Dordrecht/Riverton: Foris Publications.
- Haider, Hubert. 1990. Topicalization and other puzzles of German syntax. In *Scrambling and barriers*, eds. Günther Grewendorf and Wolfgang Sternefeld, 93-112. Amsterdam/Philadelphia: John Benjamins.
- Haider, Hubert. 2003. V-clustering and clause union: causes and effects. In *Verb constructions in German and Dutch*, eds. Pieter A.M. Seuren and Gerard Kempen, 91-126. Amsterdam/Philadelphia: John Benjamins.
- Haider, Hubert. 2010. *The syntax of German*. Cambridge: Cambridge University Press.
- Haider, Hubert, and Martin Prinzhorn. 1985. *Verb second phenomena in Germanic languages*. Dordrecht: Foris Publications.
- Hale, Ken, and Samuel Keyser. 1993. On argument structure and the lexical expression of syntactic relations. In *The view from Building 20: essays in linguistics in honor of Sylvain Bromberger*, eds. Ken Hale and Samuel Keyser, 53-109. Cambridge, MA/London: MIT Press.
- Hankamer, Jorge. 1971. *Constraints on deletion in syntax*, Yale University: PhD thesis.
- Haslinger, Irene. 2007. *The syntactic location of events. Aspects of verbal complementation in Dutch*, University of Tilburg: PhD thesis.
- Heringa, Herman. 2012. *Appositional constructions*, University of Groningen: PhD thesis.
- Hinterhölzl, Roland. 2006. *Scrambling, remnant movement and restructuring in West-Germanic*. Oxford/New York: Oxford University press.
- Hoeksema, Jack. 1991a. Theoretische aspecten van partikelvooropplaatsing. *TABU* 21:18-26.
- Hoeksema, Jack. 1994. The history of Dutch verb projection raising. Ms. University of Groningen.
- Hoeksema, Jack. 1995. Nevenschikking onder *te*. *Tabu* 25:156-157.
- Hoeksema, Jack. 2000. Verplichte topicalisatie van kale enkelvoudens: de *feit is dat*-constructie. *Tabu* 30:113-142.
- Hoeksema, Jack. 2006. *Hij zei van niet, maar knikte van ja*: distributie en diachronie van bijwoorden van polariteit ingeleid door *van*. *Tabu* 35:135-158.
- Hoeksema, Jack. 2008. *Van + bijwoord van polariteit: een geval van verplichte extrapositie?* *Tabu* 37:69-78.
- Hoekstra, Eric. 1991. *Licensing conditions on phrase structure*, University of Groningen: PhD thesis.
- Hoekstra, Eric, and Caroline Smit (eds). 1997. *Vervoegde voegwoorden*. Amsterdam: Meertens Institute.
- Hoekstra, Eric, and Jan-Wouter Zwart. 1994. De structuur van CP. Functionele projecties voor topics en vraagwoorden in het Nederlands. *Spektator* 23:191-212.
- Hoekstra, Teun. 1983. The distribution of sentential complements. In *Linguistics in the Netherlands 1983*, eds. Hans Bennis and W.U.S. van Lessen Kloeke, 93-103. Dordrecht: Foris Publications.
- Hoekstra, Teun. 1984a. *Transitivity. Grammatical relations in government-binding theory*. Dordrecht/Cinnaminson: Foris Publications.
- Hoekstra, Teun. 1988. Small clause results. *Lingua* 74:101-139.

- Hoekstra, Teun. 1999. Parallels between nominal and verbal projections. In *Specifiers: minimalist approaches*, eds. David Adger, Susan Pintzuk, Bernadette Plunkett and George Tsoulas, 163-187. Oxford/New York: Oxford University Press. [Also printed in Teun Hoekstra (2004)].
- Hoekstra, Teun. 2004. *Arguments and structure. Studies on the architecture of the sentence*. Berlin/New York: Mouton de Gruyter.
- Hoekstra, Teun, Monic Lansu, and Marion Westerduin. 1987. Complexe verba. *Glot* 10:61-77. [A translation of this paper by Frits Beukema appeared in Teun Hoekstra (2004)].
- Hoekstra, Teun, and René Mulder. 1990. Unergatives as copular verbs: locational and existential predication. *The Linguistic Review* 7:1-79.
- Hoekstra, Teun, and Ian Roberts. 1993. Middle constructions in Dutch and English. In *Knowledge of language, vol. 2: lexical and conceptual structure*, eds. Eric Reuland and Werner Abraham, 183-220. Dordrecht: Kluwer Academic Publishers.
- Honselaar, Wim. 1987. *Zijn* vs. *hebben* in het samengesteld perfectum. *De Nieuwe Taalgids* 80:55-68.
- Horn, George M. 1974. *The noun phrase constraint*, University of Massachusetts: PhD thesis.
- Hornstein, Norbert. 1990. *As time goes by: tense and universal grammar*. Cambridge, MA: MIT Press.
- Hornstein, Norbert. 1995. *Logical Form: from GB to minimalism*. Oxford: Blackwell.
- Hornstein, Norbert. 2001. *Move! A minimalist theory of construal*. Malden, MA/Oxford (UK): Blackwell Publishers.
- Hornstein, Norbert, and Maria Polinsky (eds). 2010. *Movement theory of control*. Amsterdam/Philadelphia: John Benjamins.
- Huang, Cheng-Teh James. 1982. *Logical relations in Chinese and the theory of Grammar*, MIT: PhD thesis.
- Huang, Yan. 2009. Speech acts. In *Concise encyclopedia of pragmatics*, ed. Jacob L. Mey. Amsterdam/Boston: Elsevier.
- Huddleston, Rodney, and Geoffrey Pullum (eds). 2002. *The Cambridge grammar of the English language*. Cambridge: Cambridge University Press.
- Hughes, George Edward, and M.J. Cresswell. 1968. *An introduction to modal logic*. London: Methuen.
- Hulk, Aafke, and Leonie Cornips. 1996. Réflexifs aspectuels. In *Proceedings of Langues et Grammaire 1*, eds. Léa Nash and Georges Tsoulas, 185-200: Université de Paris 8.
- Huybregts, M.A.C, and Henk van Riemsdijk. 1985. Parasitic gaps and ATB. In *Proceedings of NELS 15*, 168-187. Amherst: GLSA, University of Massachusetts.
- Huybregts, Riny. 1991. Clitics. In *Grammatische analyse*, ed. Jan Model, 279-330. Dordrecht: ICG Printing.
- Ijbema, Aniek. 2002. *Grammaticalization and infinitival complements in Dutch*, University of Leiden: PhD thesis.
- Jackendoff, Ray. 1972. *Semantic interpretation in generative grammar*. Cambridge, MA: MIT Press.
- Jaegli, Osvaldo. 1986. Passive. *Linguistic Inquiry* 17:587-622.

- Jansen, Frank. 1981. *Syntaktische konstrukties in gesproken taal*. Amsterdam: Huis aan de drie grachten.
- Janssen, Theo. 1976. *Hebben-konstrukties en indirect-objektconstructies*, University of Nijmegen: PhD thesis.
- Janssen, Theo. 1977. Het wel en niet omschreven indirect objekt en de possessieve datief. *Tijdschrift voor Nederlandse Taal- en Letterkunde* 93:203-230.
- Janssen, Theo. 1983. Het temporele systeem van het Nederlands:drie tijden en twee tijdscomposities. *Glott* 6:45-104.
- Janssen, Theo. 1989. Die Hilfsverben nld. *zullen* und dt. *werden*: modal oder temporal? In *Tempus-Aspekt-Modus: Die lexikalischen und grammatischen Formen in den germanischen Sprachen*, eds. Werner Abraham and Theo Janssen, 65-84. Tübingen: Max Niemeyer Verlag.
- Janssen, Theo. 1989. Tempus: interpretatie en betekenis. *De Nieuwe Taalgids* 82:305-329.
- Janssen, Theo. 1992. Controle: een onbeheersbaar onderwerp in de regeer- en bindtheorie. *Spektator* 21:327-344.
- Jaworska, Ewa. 1999. Control. In *Concise encyclopedia of grammatical categories*, eds. Keith Brown and Jim Miller, 107-110. Amsterdam (etc): Elsevier.
- Johnson, Kyle. 1991. Object positions. *Natural Language & Linguistic Theory* 9:577-636.
- Jónsson, Jóhannes G. 1996. *Clausal architecture and case in Icelandic*, GLSA: University of Massachusetts: PhD thesis.
- Kaan, Edith. 1992. *A minimalist approach to extraposition*, University of Groningen: MA thesis.
- Kaan, Edith. 1997. *Processing subject-object ambiguities in Dutch*, University of Groningen: PhD thesis.
- Kayne, Richard S. 1975. *French syntax: the transformational cycle*. Cambridge, MA: MIT Press.
- Kayne, Richard S. 1976. French relative *que*. In *Current studies in Romance linguistics*, eds. Marta Lujan and Fritz Hensley, 255-299. Washington (D.C.): Georgetown University Press.
- Kayne, Richard S. 1984. *Connectedness and binary branching*. Dordrecht: Foris Publications.
- Kayne, Richard S. 1994. *The antisymmetry of syntax*. Cambridge, MA: MIT Press.
- Kayne, Richard S. 1998. Overt vs. Covert Movement. *Syntax* 1:128-191.
- Kayne, Richard S. 2000. *Parameters and universals*. New York: Oxford University Press.
- Kayne, Richard S. 2004. Prepositions as probes. In *Structures and beyond*, ed. Adriana Belletti, 192-212. New York: Oxford University Press. Reprinted in Richard S. Kayne (2005), *Movement and silence*. New York: Oxford University Press.
- Kempen, Gerard, and Karin Harbusch. 2003. Dutch and German verb constructions in Performance Grammar. In *Verb constructions in German and Dutch*, eds. Pieter Seuren and Gerard Kempen, 185-221. Amsterdam/Philadelphia: John Benjamins.
- Kerstens, Johan. 1975. Over de afgeleide structuur en interpretatie van zinnen. Ms. University of Amsterdam.

- Keyser, Samuel, and Thomas Roeper. 1984. On the middle and ergative constructions in English. *Linguistic Inquiry* 15:381-416.
- Kiparsky, Paul, and Carol Kiparsky. 1970. Fact. In *Progress in linguistics*, eds. Manfred Bierwisch and Karl Erich Heidolph, 143-173. The Hague/Paris: Mouton.
- Kirsner, Robert. 1976. De "onechte lijdende vorm". *Spektator* 6:1-18.
- Klein, Henny. 1997. *Adverbs of degree in Dutch*, University of Groningen: PhD thesis.
- Klein, M. 1977. *Appositionele constructies in het Nederlands*, University of Nijmegen: PhD thesis.
- Klein, Maarten. 1979. Paardekoopers notie *aanloop* and het bestaansrecht van subjectzinnen. *Gramma* 3:87-223.
- Klima, Edward S. 1964. Negation in English. In *The structure of language. Readings in the philosophy of language*, eds. J.A. Fodor and J.J. Katz, 246-323. Englewood Cliffs NJ: Prentice-Hall.
- Klooster, Wim. 1972. *The structure underlying measure phrase sentences*. Dordrecht: Reidel.
- Klooster, Wim. 1984. Ontkenning en noodzakelijkheid. Observaties met betrekking tot negatie en *moeten*. *Glott* 7:63-120.
- Klooster, Wim. 1986. Problemen met complementen. *Tabu* 16:122-132.
- Klooster, Wim. 1989. Bananenzinnen. In *Liber amicorium Kåre Langvik-Johanessen*, eds. Karel Porteman and Kurt Erich Schöndorf, 35-43. Leuven.
- Klooster, Wim. 1994. Syntactic differentiation in the licensing of polarity items. *HIL Manuscripts* 2:43-56.
- Klooster, Wim. 2001. *Grammatica van het hedendaags Nederlands. Een volledig overzicht*. Den Haag: SDU Uitgeverij.
- Kluck, Marlies. 2010. What you (and God) only know. In *Structure preserved. Studies in syntax for Jan Koster*, eds. Jan-Wouter Zwart and Mark De Vries, 249-255. Amsterdam/Philadelphia: John Benjamins.
- Kluck, Marlies. 2011. *Sentence amalgamation*, University of Groningen: PhD thesis.
- Koizumi, Masatoshi. 1993. Object agreement phrases and the split VP hypothesis. In *Papers on case and agreement I*, eds. Jonathan Bobaljik and Colin Phillips, 99-148: MIT.
- König, Ekkehard, and Johan Van der Auwera (eds). 1994. *The Germanic languages*. London/New York: Routledge.
- König, Ekkehart. 1991. *The meaning of focus particles. A comparative perspective*. London/New York: Routledge.
- Kooij, Jan. 1975. Diachronic aspects of idiom formation. In *Linguistics in the Netherlands 1972-1973*, ed. A. Kraak, 122-127. Assen/Amsterdam: Van Gorcum.
- Kooij, Jan. 1978. Fronting in Dutch. In *Studies on fronting*, ed. Frank Jansen, 29-52. Lisse: Peter de Ridder.
- Koopman, Hilda. 1994. Licensing heads. In *Verb movement*, eds. David Lightfoot and Norbert Hornstein, 261-296. Cambridge (UK)/New York: Cambridge University Press.
- Koopman, Hilda. 1995. De plaats van geïncorporeerde hoofden in de werkwoordscluster. *Tabu* 25:174-178.
- Koopman, Hilda. 1995. On verbs that fail to undergo V-second. *Linguistic Inquiry* 26:137-163.



- Koopman, Hilda. 2007. Topics in imperatives. In *Imperative clauses in generative grammar. Studies in honour of Frits Beukema*, ed. Wim van der Wurff, 153-180. Amsterdam/Philadelphia: John Benjamins.
- Koopman, Hilda, and Dominique Sportiche. 1982. Variables and the bijection principle. *The Linguistic Review* 2:139-160.
- Koopman, Hilda, and Dominique Sportiche. 1985. Theta-theory and extraction [abstract]. *GLOW Newsletter* 14:57-58.
- Koopman, Hilda, and Anna Szabolcsi. 2000. *Verbal complexes*. Cambridge, MA/London: MIT Press.
- Koring, Loes. 2013. *Seemingly similar. Subjects and displacement in grammar, processing, and acquisition*, University of Utrecht: PhD thesis.
- Kosmeijer, Wim. 1993. *Barriers and licensing*, University of Groningen: PhD thesis.
- Koster, Jan. 1973. PP over V en de theorie van J. Emonds. *Spektator* 2:294-309.
- Koster, Jan. 1974. Het werkwoord als spiegelcentrum. *Spektator* 3:601-618.
- Koster, Jan. 1975. Dutch as an SOV language. *Linguistic Analysis* 1:111-136.
- Koster, Jan. 1978. *Locality principles in syntax*. Dordrecht: Foris Publications.
- Koster, Jan. 1978. Why subject sentences don't exist. In *Recent transformational studies in European languages*, ed. S. Jay Keyser, 53-64.
- Koster, Jan. 1984a. Infinitival complements in Dutch. In *Sentential complementation*, eds. Wim de Geest and Yvan Putseys, 141-150: Foris Publications.
- Koster, Jan. 1984b. Anaphoric and non-anaphoric control. *Linguistic Inquiry* 15:417-459. Reprinted in Jan Koster (1987), *Domains and dynasties. The radical autonomy of syntax*. Dordrecht/Providence: Foris Publications.
- Koster, Jan. 1987. *Domains and dynasties. The radical autonomy of syntax*. Dordrecht/Providence: Foris Publications.
- Koster, Jan. 1995. Lege objecten. *Tabu* 25:179-184.
- Koster, Jan. 1999. Empty objects in Dutch. Ms. University of Groningen, <http://odur.let.rug.nl/~koster/papers/e-objects.pdf>.
- Koster, Jan. 2000. Extraposition as parallel construal. Ms. University of Groningen, [odur.let.rug.nl/~koster/papers/parallel.pdf](http://odur.let.rug.nl/~koster/papers/parallel.pdf).
- Koster, Jan, and Robert May. 1982. On the constituency of infinitives. *Language* 58:116-143.
- Kraak, A., and Wim Klooster. 1972. *Syntaxis*. Culemborg: Stam/Robijns.
- Krijgsman, K.J. 1983. *Wat-uitroepen en wh-verplaatsing*. *GLot* 5:123-156.
- Kroch, Anthony S., and Beatrice Santorini. 1991. The derived constituent structure of the West Germanic Verb-Raising construction. In *Principles and parameters in comparative grammar*, ed. Robert Freiding, 269-338. Cambridge, Mass/London: MIT Press.
- Lakoff, George. 1974. Syntactic amalgams. In *Papers from the 10th regional meeting of the Chicago Linguistic Society*, eds. Michael Galy, Robert Fox and Anthony Bruck, 321-344. Chicago: University of Chicago.
- Landsbergen, Frank. 2009. *Cultural evolutionary modeling of patterns in language change. Exercises in evolutionary linguistics*, University of Leiden: PhD thesis.
- Larson, Richard. 1985. Bare NP adverbs. *Linguistic Inquiry* 16:595-621.
- Lasnik, Howard. 1999. *Minimalist analysis*. Oxford: Blackwell.
- Lasnik, Howard, and Mamoru Saito. 1992. *Move  $\alpha$ . Conditions on its applications and output*. Cambridge, MA/London: MIT Press.



- Lattewitz, Karen. 1993. A minimalist view on Verb Raising. In *Language and Cognition 3. University of Groningen*, eds. Ale de Boer, Jelle de Jong and Rita Landeweerd, 159-169. Groningen: University of Groningen.
- Lattewitz, Karen. 1997. *Adjacency in Dutch and German*, University of Groningen: PhD thesis.
- Lebeaux, David. 1984. Anaphoric binding and the definition of PRO. *Proceedings of NELS 14*:253-274.
- Lee, Young-Suk, and Beatrice Santorini. 1994. Towards resolving Weibelhuth's paradox: evidence from German and Korean. In *Studies on Scrambling: movement and non-movement approaches to free word-order phenomena*, eds. Norbert Corver and Henk Van Riemsdijk, 257-300. Berlin/New York: Mouton de Gruyter.
- Lehmann, C. 1999. Aspectual type(s). In *Concise encyclopedia of grammatical categories*, eds. Keith Brown and Jim Miller, 43-49. Oxford: Elsevier.
- Lenerz, Jürgen. 1977. *Zur Abfolge nominaler Satzglieder im Deutschen. Studien zur deutschen Grammatik 5*. Tübingen: Narr.
- Levin, Beth. 1993. *English verb classes and alternations*: University of Chicago Press.
- Levin, Beth, and Malka Rappaport Hovav. 1995. *Unaccusativity at the syntax-lexical semantics interface*. Cambridge, MA/London: MIT Press.
- Levin, Beth, and Malka Rappaport Hovav. 2005. *Argument realization*. Cambridge/New York: Cambridge University Press.
- Lightfoot, David, and Norbert Hornstein (eds). 1994. *Verb movement*. Cambridge/New York: Cambridge University Press.
- Lodewick, H.J.M.F. 1975. *Literaire kunst*. Den Bosch: Malmberg.
- Loonen, Nard. 2003. *Stante pede gaande van dichtbij langs AF bestemming @*, University of Utrecht: PhD thesis.
- Mahajan, Anoop. 1990. *The A/A-bar distinction and movement theory*, MIT: PhD thesis.
- Mahajan, Anoop. 1994. Toward a unified theory of scrambling. In *Studies on Scrambling. Movement and non-movement approaches to word-order phenomena*, eds. Norbert Corver and Henk van Riemsdijk, 301-330. Berlin/New York: Mouton de Gruyter.
- Maienborn, Claudia. 2001. On the position and interpretation of locative modifiers. *Natural Language Semantics 9*:191-240.
- Maienborn, Claudia, and Martin Schäfer. 2011. Adverbs and adverbials. In *Semantics. an international handbook of natural language meaning, volume 2*, eds. Klaus von Heusinger, Claudia Maienborn and Paul Portner, 1390-1420. Berlin/Boston: De Gruyter/Mouton.
- Maling, Joan , and Annie Zaenen. 1978. The nonuniversality of a surface filter. *Linguistic Inquiry 9*:475-497.
- Manzini, Maria Rita. 1983. On control and control theory. *Linguistic Inquiry 14*:421-446.
- May, Robert. 1985. *Logical form: its structure and derivation*. Cambridge, MA: MIT Press.
- McCawley, James D. 1988. Adverbial NPs: bare or clad in see-through garb? *Language 64*:583-590.
- Merchant, Jason. 2001. *The syntax of silence: sluicing, islands and the theory of ellipsis*. Oxford/New York: Oxford University Press.
- Merchant, Jason. 2004. Fragments and ellipsis. *Linguistics and Philosophy 27*:661-738.

- Merchant, Jason. 2006. Sluicing. In *The Blackwell companion to syntax, Volume IV*, eds. Martin Everaert and Henk van Riemsdijk, 271-291. Malden, Ma/Oxford: Blackwell Publishing.
- Miller, Jim. 1999. Aspect: Further developments. In *Concise encyclopedia of grammatical categories*, eds. Keith Brown and Jim Miller, 43-49. Amsterdam: Elsevier.
- Milsark, Gary. 1974. *Existential sentences in English*, MIT: PhD thesis.
- Milsark, Gary. 1977. Toward an explanation of certain peculiarities of the existential construction in English. *Linguistic Analysis* 3:1-29.
- Mulder, René. 1992. *The aspectual nature of syntactic complementation*, HIL Dissertations, University of Leiden: PhD thesis.
- Mulder, René, and Pim Wehrmann. 1989. Locational verbs as unaccusatives. In *Linguistics in the Netherlands 1989*, eds. Hans Bennis and Ans Van Kemenade, 111-122. Dordrecht: Foris Publications.
- Müller, Gereon. 1998. *Incomplete category fronting. A derivational approach to remnant movement in German*. Dordrecht/Boston/London: Kluwer Academic Publishers.
- Müller, Gereon. 2000. Shape conservation and remnant movement. In *Proceedings of NELS 30*, eds. A. Hirotani, N. Hall Coetzee and J.-Y. Kim, 525-539. Amherst, MA: GLSA.
- Müller, Gereon. 2001. Order preservation, parallel movement, and the emergence of the unmarked. In *Optimality-theoretic syntax*, eds. Géraldine Legendre, Jane Grimshaw and Sten Vikner, 113-142. Cambridge, MA/London: MIT Press/MITWPL.
- Müller, Gereon. 2011. *Constraints on displacement. A phase-based approach*. Amsterdam/Philadelphia: John Benjamins.
- Müller, Gereon, and Wolfgang Sternefeld. 1994. Scrambling as A-bar movement In *Studies on scrambling. Movement and non-movement approaches to free word-order phenomena*, eds. Norbert Corver and Henk van Riemsdijk, 331-386. Berlin/New York: Mouton de Gruyter.
- Neeleman, Ad. 1994a. Scrambling as a D-structure phenomenon. In *Studies on scrambling. Movement and non-movement approaches to free word-order phenomena*, eds. Norbert Corver and Henk van Riemsdijk, 387-429. Berlin/New York: Mouton de Gruyter.
- Neeleman, Ad. 1994b. *Complex predicates*, University of Utrecht: PhD thesis.
- Neeleman, Ad, and Hans Van de Koot. 2008. Dutch scrambling and the nature of discourse templates. *The Journal of Comparative Germanic Linguistics* 11:137-189.
- Neeleman, Ad, and Reiko Vermeulen. 2012. The syntactic expression of information structure. In *The syntax of topic, focus, and contrast. An interface-based approach*, eds. Ad Neeleman and Reiko Vermeulen, 1-38. Berlin/Boston: De Gruyter Mouton.
- Neeleman, Ad, and Reiko Vermeulen. 2012. *The syntax of topic, focus, and contrast. An interface-based approach*. Berlin/Boston: De Gruyter Mouton.
- Neeleman, Ad, and Fred Weerman. 1993. The balance between syntax and morphology: Dutch particles and resultatives. *Natural Language & Linguistic Theory* 11:433-475.

- Neeleman, Ad, and Fred Weerman. 1999. *Flexible syntax. A theory of case and arguments*. Dordrecht/Boston/London: Kluwer.
- Neijt, Anneke. 1979. *Gapping. A contribution to sentence grammar*, University of Utrecht: PhD Thesis.
- Nouwen, Rick, and Anna Chernilovskaya. 2013. *Wh-exclamatives with and without scales*. Ms. University of Utrecht.
- Nouwen, Rick, and Anna Chernilovskaya. 2014. *Two types of wh-exclamatives*. Ms. University of Utrecht.
- Nye, Rachel. 2013. Rethinking the distribution of English finite complements: evidence from complementiser *how* clauses. In *Linguistics in the Netherlands 2013*, eds. S. Aalberse and A. Auer, 119-130. Amsterdam/Philadelphia: John Benjamins.
- Odiijk, Jan. 1995. Topicalization of sentences in Dutch is contrastive dislocation. Eindhoven: Institute for perception research.
- Odiijk, Jan. 1998. Topicalization of non-extraposed complements in Dutch. *Linguistic Inquiry* 16:191-222.
- Oehrle, Richard Thomas. 1976. *The grammatical status of the English dative alternation*, MIT: PhD thesis.
- Oosterhof, Albert. 2008. *The semantics of generics in Dutch and related languages*. Amsterdam/Philadelphia: John Benjamins.
- Ott, Dennis. 2014. An ellipsis approach to contrastive left dislocation. *Linguistic Inquiry* 45:269-303.
- Ott, Dennis, and Mark De Vries. 2015. Right dislocation as deletion. *Natural Language & Linguistic Theory* 33.
- Paardekooper, P.C. 1960. *Inleiding tot de ABN-syntaksis*. Den Bosch: L.C.G.Malmberg.
- Paardekooper, P.C. 1961. Persoonsvorm en voegwoord. *De Nieuwe Taalgids* 54:296-301.
- Paardekooper, P.C. 1985. Indeling van de *om*-zinnen en indelingen met behulp daarvan. *GLOT* 8:127-128.
- Paardekooper, P.C. 1986. *Beknopte ABN-syntaksis*. Eindhoven: P.C. Paardekooper.
- Palmer, F.R. 2001. *Mood and modality*, 2nd edition. Cambridge: Cambridge University Press.
- Pankau, Andreas. 2014. *Replacing copies: the syntax of wh-copying in German*, University of Utrecht: PhD thesis.
- Pardoen, Justine. 1986. Werkwoordclustering in the voltooide tijd. *Voortgang* 8:49-76.
- Pauwels, A. 1953. *De plaats van hulpwerkwoord, verleden deelwoord en infinitief in de Nederlandse bijzin*. Leuven: Drukkerij M. & L.Symons.
- Pauwels, J.L. 1958. *Het dialect van Aarschot en omstreken*: Belgisch Interuniversitair Centrum voor Neerlandistiek.
- Perlmutter, D.M. 1978. Impersonal passives and the unaccusative hypothesis. *Berkeley Linguistics Society* 4:157-189.
- Pesetsky, David. 1987. *Wh-in-situ: movement and unselective binding*. In *The representation of (in)definiteness*, eds. Eric Reuland and Alice Ter Meulen. Cambridge, MA/London: MIT Press.
- Pesetsky, David. 1991. *Zero syntax volume 2: infinitives*. Ms. MIT.
- Pesetsky, David. 1995. *Zero syntax: experiencers and cascades*. Cambridge, MA: MIT Press.

- Pesetsky, David. 1997. Optimality theory and syntax: movement and pronunciation. In *Optimality theory*, eds. Diana Archangeli and Terence Langendoen, 134-170. Malden/Oxford: Blackwell.
- Pesetsky, David. 1998. Some optimality principles of sentence pronunciation. In *Is the best good enough?*, eds. Pilar Barbosa, Danny Fox, Paul Hagstrom, Martha McGinnis and David Pesetsky, 337-383. Cambridge, MA/London: MIT Press/MITWPL.
- Petter, Marga. 1998. *Getting PRO under control. A syntactic analysis of the nature and distribution of unexpressed subjects in non-finite and verbless clauses*, Free University Amsterdam: PhD thesis.
- Pollman, Thijs. 1970. Passieve zinnen en het geïmpliceerd logisch subject. *Studia Neerlandica* 2:34-50.
- Pollman, Thijs. 1975. *Oorzaak en handelende persoon*, University of Nijmegen: PhD thesis.
- Pollock, Jean-Yves. 1989. Verb movement, universal grammar and the structure of IP. *Linguistic Inquiry* 20:365-424.
- Pope, Emily. 1971. Answers to Yes-No questions. *Linguistic Inquiry* 2:69-82.
- Postma, Gertjan. 2011. Het verval van het pronomen *du* - dialectgeografie en de historische syntaxis. *Nederlandse Taalkunde* 16:56-87.
- Postma, Gertjan. 2013. Forumlezingen in imperatieven: lexicale constructies of productieve syntaxis. *Nederlandse Taalkunde* 18:268-288.
- Postma, Gertjan, and Johan Rooryck. 2007. Phase-recursion, restricted linguistic systems, and full language: Meertens Institute/Leiden University
- Postma, Gertjan, and Wim van der Wurff. 2007. How to say *no* and *don't*: negative imperatives in Romance and Germanic. In *Imperative clauses in generative grammar. Studies in honour of Frits Beukema*, ed. Wim van der Wurff, 205-249. Amsterdam/Philadelphia: John Benjamins.
- Prince, Alan, and Paul Smolensky. 2004. *Optimality theory: constraint interaction in generative grammar*. Malden, MA/Oxford: Blackwell.
- Prior, Arthur. 1967. *Past, present and future*. Oxford: Oxford University Press.
- Proeme, Henk. 1984. Over de Nederlandse imperativus. *Forum der Letteren* 25:241-258.
- Proeme, Henk. 1986. Is *wees* imperativus van *zijn*? (over de semantiek van *wezen* en *zijn*). *Forum der Letteren* 27:30-41.
- Progovac, Ljiljana. 1994. *Negative and positive polarity. A binding approach*. Cambridge (UK): Cambridge University Press.
- Quirk, Randolph, Sidney Greenbaum, Geoffrey Leech, and Jan Svartvik. 1979. *A grammar of contemporary English*. London: Longman.
- Quirk, Randolph, Sidney Greenbaum, Geoffrey Leech, and Jan Svartvik. 1985. *A comprehensive grammar of the English language*. London/New York: Longman.
- Rappaport Hovav, Malka, and Beth Levin. 2008. The English dative alternation: the case for verb sensitivity. *Journal of Linguistics* 44:129-167.
- Reichenbach, Hans. 1947. *Elements of symbolic logic* (1966 paperback edition). New York: The Free Press.
- Reinhart, Tanya. 1980. On the position of extraposed clauses. *Linguistic Inquiry* 11:621-624.

- Reinhart, Tanya. 1983. Point of view in language. The use of parentheticals. In *Essays on Deixis*, ed. Gisa Rauh, 169-194. Tübingen: Gunter Narr Verlag.
- Reinhart, Tanya, and Eric Reuland. 1993. Reflexivity. *Linguistic Inquiry* 24:657-720.
- Reis, Marga. 1976. Reflexivierung in deutsche A.c.I.-konstruktionen, Ein transformationsgrammatisches Dilemma. *Papiere zur Linguistik* 9:5-82.
- Reuland, Eric. 1981. On extraposition of complement clauses. *NELS* 11:296-318.
- Reuland, Eric. 1985. Representation at the level of Logical Form and the Definiteness Effect. In *Grammatical representation*, eds. Jacqueline Guéron, Hans-Georg Obenauer and Jean-Yves Pollock, 327-362. Dordrecht: Foris Publications.
- Reuland, Eric. 1983. Government and the search for *auxes*, Vol. 1. In *Linguistic categories: auxiliaries and related puzzles*, eds. Frank Heny and Barry Richards, 99-168. Dordrecht: Reidel.
- Rijkhoek, Paulien. 1998. *On degree phrases & result clauses*, University of Groningen: PhD Thesis.
- Rizzi, Luigi. 1982. *Issues in Italian Syntax*. Dordrecht/Cinnaminson: Foris Publications.
- Rizzi, Luigi. 1990. *Relativized minimality*. Cambridge, MA/London: MIT Press.
- Rizzi, Luigi. 1996. Residual verb second and the wh-criterion. In *Parameters and functional heads. Essays in comparative syntax*, eds. Adriana Belletti and Luigi Rizzi, 63-90. Oxford/New York: Oxford University Press.
- Rizzi, Luigi. 1997. The fine structure of the left periphery. In *Elements of grammar. Handbook of generative grammar*, ed. Liliane Haegeman, 281-337. Dordrecht/Boston/ Londen: Kluwer Academic Publishers.
- Roberts, Ian. 1987. *The representation of implicit and dethematized subjects*. Dordrecht: Foris Publications.
- Roberts, Ian. 1999. Passive and related constructions. In *Concise encyclopedia of grammatical categories*, eds. Keith Brown and Jim Miller, 264-290. Amsterdam: Elsevier.
- Romein, Kirsten. 1999. Ik schrijf van niet, maar ik zeg van wel. *Tabu* 29:173-178.
- Romero-Trillo, Jesús. 2009. Discourse markers. In *Concise Encyclopedia of Pragmatics (2nd ed.)*, ed. Jacob L. Mey, 191-194. Amsterdam: Elsevier.
- Rooryck, Johan, and Gertjan Postma. 2007. On participial imperatives. In *Imperative clauses in generative grammar. Studies in honour of Frits Beukema*, ed. Wim van der Wurff, 273-296. Amsterdam/Philadelphia: John Benjamins.
- Rosen, Sara Thomas. 2003. The syntactic representation of linguistic events. In *The second Glot International state-of-the-article book. The latest in linguistics*, eds. Lisa Cheng and Rint Sybesma, 323-367. Berlin/New York: Mouton de Gruyter.
- Rosenbaum, Peter S. 1967. *The grammar of English predicate complement constructions*. Cambridge (Mass.): MIT Press.
- Ross, John. 1967. *Constraints on variables in syntax*. Bloomington: Indiana university linguistics club.
- Rutten, Jean. 1991. *Infinitival complements and auxiliaries*, University of Amsterdam: PhD thesis.
- Ruys, E.G. 2008. Stranding, weak pronouns, and the fine structure of the middle field. *Natural Language & Linguistic Theory* 26:547-587.
- Safir, Ken. 1983. On small clauses as constituents. *Linguistic Inquiry* 14:730-735.

- Safir, Ken. 1987. The anti-c-command condition on parasitic gaps. *Linguistic Inquiry* 18:678-683.
- Salverda, Reinier. 1982. On the problem of topicalization in Dutch. *Vooruit* 3:244-255.
- Salverda, Reinier. 2000. On topicalization in Modern Dutch. In *The Berkeley conference on Dutch linguistics 1997. The Dutch language at the millennium*, eds. Thomas F. Shanno and Johan P. Snapper, 93-111. Lanham/New York/Oxford: University Press of America.
- Salzmann, Martin. 2006. *Resumptive prolepsis. A study in indirect A'-dependencies*, University of Leiden: PhD thesis.
- Sanders, José, and Wilbert Spooren. 1996. Subjectivity and certainty in epistemic modality: A study of Dutch epistemic modifiers. *Cognitive Linguistics* 7:241-264.
- Sassen, Albert. 1977-8. Hij is vissen/wezen vissen. *Tabu* 8:38-42.
- Schäfer, Florian. 2008. *The syntax of (anti-)causatives. External arguments in change-of-state contexts*. Amsterdam/Philadelphia: John Benjamins.
- Schermer-Vermeer, E.C. 1988. De grammatische status van het zogenaamde voorzetselvoorwerp. *Glott* 11:11-26.
- Schermer-Vermeer, E.C. 1990. Het voorzetselvoorwerp en het begrip "vorm". *De Nieuwe Taalgids* 83:238-247.
- Schermer-Vermeer, E.C. 1991. *Substantiële versus formele taalbeschrijving: het indirect object in het Nederlands*, Universiteit van Amsterdam: PhD thesis.
- Schermer-Vermeer, E.C., and H. Hadderingh. 1994. Enkele aspecten van het voorzetselvoorwerp. *Forum der Letteren* 35:231-234.
- Schermer-Vermeer, Ina. 1986. *Laten* als vorm van een nieuwe wijs. *Spektator* 15:348-358.
- Schermer-Vermeer, Ina. 1996. De beschrijving van de possessieve datief. *Nederlandse Taalkunde* 1:265-279.
- Schermer-Vermeer, Ina. 2001. Grammatica, lexicon en de dubbelobject-constructie in het Nederlands en het Engels. *Nederlandse Taalkunde* 6:22-37.
- Schermer-Vermeer, Ina. 2006. Worstelen met het voorzetselvoorwerp. *Nederlandse Taalkunde* 11:146-167.
- Schermer-Vermeer, Ina. 2007. Worstelen rond het voorzetselvoorwerp: een reactie op de opmerkingen van Hans Broekhuis. *Nederlandse Taalkunde* 12:358-365.
- Scherpenisse, Wim. 1985. Scrambling in German. *Groninger Arbeiten zur Germanistischen Linguistik* 26:61-78.
- Schiffrin, Deborah. 1987. *Discourse Markers*. Cambridge: Cambridge University Press.
- Schippers, Ankelien. 2012. *Variation and change in Germanic long-distance dependencies*, University of Groningen: PhD thesis.
- Schmid, Tanja. 2005. *Infinitival syntax. Infinitivus Pro Participio as a repair strategy*. Amsterdam/Philadelphia: John Benjamins.
- Schmid, Tanja, and Ralf Vogel. 2004. Dialectal variation in German 3-verb clusters: a surface-oriented optimality theoretic account. *The Journal of Comparative Germanic Linguistics* 7:235-274.
- Schuurman, Ineke. 1987. Incorporation in the Groningen dialect. In *Linguistics in the Netherlands 1987*, eds. Frits Beukema and Peter Coopmans, 185-194. Dordrecht: Foris Publications.



- Schweikert, Walter. 2005. *The order of prepositional phrases in the structure of the clause*. Amsterdam/Philadelphia: John Benjamins.
- Searle, John R. 1975. Indirect speech acts. In *Syntax and Semantics, volume 3. Speech acts*, eds. Peter Cole and Jerry L. Morgan, 59-82. New York: Academic Press.
- Seuren, Pieter, and Camiel Hamans. 2009. Semantic conditions on syntactic rules: evidentiality and auxiliation in English and Dutch. *Folia Linguistica* 43:135-169.
- Sheehan, Michelle. 2010. Extraposition and antisymmetry. *Linguistic Variation Yearbook* 10:201-251.
- Smith, Carlota. 1991. *The parameter of aspect*. Dordrecht: Kluwer Academic Publishers.
- Smits, R.J.C. 1989. *The relative and cleft constructions of the Germanic and Romance languages*, Tilburg University: PhD thesis.
- Smits, Rik. 1987. Over de *aan het* constructie, lexicale morfologie en casustheorie. In *Grammaticaliteiten*, eds. Norbert Corver and Jan Koster, 281-324: University of Tilburg.
- Sportiche, Dominique. 1988. A theory of floating quantifiers and its corollaries for constituent structure. *Linguistic Inquiry* 19:425-449.
- Sportiche, Dominique. 2006. Reconstruction, binding and scope. In *The Blackwell companion to syntax, Volume IV*, eds. Martin Everaert and Henk van Riemsdijk, 35-93. Malden, Ma/Oxford: Blackwell Publishers.
- Steinbach, Markus 2002. *Middle voice. A comparative study in the syntax-semantics interface of German*. Amsterdam/Philadelphia: John Benjamins.
- Stowell, Tim. 1981. *Origins of phrase structure*, MIT: PhD thesis.
- Stowell, Tim. 1983. Subjects across categories. *The Linguistic Review* 2:285-312.
- Stroop, Jan. 2009. Twee- en meerledige werkwoordsgroepen in gesproken Nederlands. In *Fons Verborum. Feestbundel Fons Moerdijk* eds. Egbert Beijk et al., 459-469. Leiden: Instituut voor Nederlandse Lexicologie.
- Sturm, Arie. 1990. Herschrijven. *Forum der Letteren* 31:271-290.
- Sturm, Arie. 1996. Over functionele projecties. *Nederlandse Taalkunde* 1:191-206.
- Svenonius, Peter. 2000. Quantifier Movement in Icelandic. In *The derivation of VO and OV*, ed. Peter Svenonius, 255-292. Amsterdam: John Benjamins.
- Szabolsci, Anna. 2006. Strong vs. weak islands. In *The Blackwell companion to syntax, Volume IV*, eds. Martin Everaert and Henk van Riemsdijk. Malden, MA/Oxford: Blackwell Publishing.
- Tallerman, Maggie. 2015. *Understanding syntax (fourth edition)*. London/New York: Routledge.
- Te Winkel, L.A. 1866. Over de wijzen en tijden der werkwoorden. *De Taalgids* 8:66-75.
- Tejedor, Laura. 2013. *Intersubjectivity in insubordination. Emotional and humorous effects of independent dat clauses in Dutch*, University of Leiden: MA thesis.
- Temmerman, Tanja. 2013. The syntax of Dutch embedded fragment answers. *Natural Language & Linguistic Theory* 31:235-285.
- Tenny, Carol L. 1994. *Aspectual roles and the syntax-semantics interface*. Dordrecht: Kluwer.
- Ter Beek, Janneke. 2008. *Restructuring and infinitival complements*, University of Groningen: PhD thesis.
- Terwey, Tijs. 1891. Woordverklaring. Over 'laten'. *Taal en Letteren* 1:273-275.



- Thrift, Erica. 2003. *Object drop in the L1 acquisition of Dutch*, University of Amsterdam: PhD thesis.
- Travis, Lisa. 1984. *Parameters and effects of word order variation*, MIT: PhD thesis.
- Truckenbrodt, Hubert. 1995. Extraposition from NP and prosodic structure. In *Proceedings of NELS 25, Vol. 2*, ed. Jill Beckman, 503-517.
- Van Bart, Peter, Johan Kerstens, and Arie Sturm. 1998. *Grammatica van het Nederlands. Een inleiding*. Amsterdam: Amsterdam University Press.
- Van Bree, C. 1981. *Hebben-constructies en datiefconstructies binnen het Nederlands taalgebied: een taalgeografisch onderzoek*, University of Leiden: PhD thesis.
- Van Bruggen, Femmy. 1980/1. Schijnen, lijken, blijken. *Tabu* 11:54-63.
- Van Craenenbroeck, Jeroen. 2002. Van as a marker of dissociation. Microvariation in Dutch. In *Studies in comparative Germanic syntax. Proceedings from the 15th workshop on comparative Germanic syntax*, eds. Jan-Wouter Zwart and Werner Abraham, 41-67. Amsterdam/Philadelphia: John Benjamins.
- Van Craenenbroeck, Jeroen. 2010. *The syntax of ellipsis. Evidence from Dutch dialects*. Oxford/New York: Oxford University Press.
- Van de Koot, Hans. 2009. A'-scrambling: wat markeert het? *Nederlandse Taalkunde* 14:313-343.
- Van den Berg, Evert 1978. Fokus presuppositie en NP-preposing. *De Nieuwe Taalgids* 71:212-222.
- Van den Hoek, Theo. 1972. Woordvolgorde en konstituentenstructuur. *Spektator* 1:125-136.
- Van den Toorn, M.C. 1971. Enkele opmerkingen over het indirect object. *Levende Talen* 274:32-71.
- Van den Toorn, M.C. 1971. Het voorzetselvoorwerp als nominale constituent. *Studia Neerlandica* 6:114-130.
- Van den Toorn, M.C. 1975. Over de semantische kenmerken van *staan*, *liggen* en *zitten*. *De Nieuwe Taalgids* 68:458-464.
- Van den Toorn, M.C. 1981. *Nederlandse grammatica*. Groningen: Wolters-Noordhoff: 7<sup>th</sup> revised edition.
- Van der Auwera, Johan. 1984. Subject vs non-subject asymmetries in the relativization of embedded NP's. In *Sentential complementation*, eds. Wim de Geest and Yvan Putseys, 257-269. Dordrecht/Cinnaminson: Foris Publications.
- Van der Horst, Joop. 2008. *Geschiedenis van de Nederlandse syntaxis, Vols. 1 & 2*. Leuven: Universitaire Pers Leuven.
- Van der Horst, Joop, and Kees van der Horst. 1999. *Geschiedenis van het Nederlands in de twintigste eeuw*. Den Haag/Antwerpen: Sdu Uitgevers & Standaard Uitgeverij.
- Van der Leek, Frederike. 1988. ZICH en ZICHZELF: syntaxis en semantiek II. *Spektator* 17:211-241.
- Van der Putten, Frans. 1986. Deverbal adjectives: grammatical or thematic relations. In *Linguistics in the Netherlands 1986*, eds. Frits Beukema and Aafke Hulk, 179-188. Dordrecht: Foris Publications.
- Van der Putten, Frans. 1997. *Mind and matter in morphology. Syntactic and lexical deverbal morphology in Dutch*, University of Leiden: PhD thesis.
- Van Dreumel, Simon, and Peter-Arno Coppen. 2003. Surface analysis of the verbal cluster in Dutch. *Linguistics* 41:51-81.

- Van Haaften, Ton. 1985. *Om-zinnen en predikatie*. *Glot* 8:47-65.
- Van Haaften, Ton. 1991. *De interpretatie van verzwegen subjecten*, Free University Amsterdam: PhD thesis.
- Van Haeringen, C.B. 1939. Congruerende voegwoorden. *Tijdschrift voor Nederlandse Taal en Letterkunde* 58:161-176.
- Van Hoof, Hanneke. 2006. Split topicalization. In *The Blackwell companion to syntax, Volume IV*, eds. Martin Everaert and Henk van Riemsdijk, 410-465. Malden, Ma/Oxford: Blackwell Publishing.
- Van Hout, Angeliek. 1996. *Event semantics of verb frame alternations: a case study of Dutch and its acquisition*, Tilburg University: PhD thesis.
- Van Leeuwen, Maarten. 2006. *Een baan aangeboden krijgen? Dat krijg je nooit gedaan! Een synchroon en diachroon onderzoek naar de gebruiksmogelijkheden van krijgen + participium in het kader van de constructiegrammatica*, University Leiden (Dutch Department): Bachelor thesis.
- Van Linden, An, and Freek Van de Velde. 2014. (Semi-)autonomous subordination in Dutch: structures and semantic-pragmatic values. *Journal of Pragmatics* 60:226-250.
- Van Riemsdijk, Henk. 1978. *A case study in syntactic markedness: the binding nature of prepositional phrases*. Lisse: Peter de Ridder Press.
- Van Riemsdijk, Henk. 1983. The case of the German adjectives. In *Linguistic Categories: Auxiliaries and related Puzzles, Vol. 1*, eds. Frank Heny and B. Richards, 223-252. Dordrecht: Reidel.
- Van Riemsdijk, Henk. 1997. Left dislocation. In *Materials on left dislocation*, eds. Elena Anagnostopoulou, Henk van Riemsdijk and Frans Zwarts, 1-10. Amsterdam/Philadelphia: John Benjamins.
- Van Riemsdijk, Henk. 2000. Wh-prefixes. The case of *wäisch* in Swiss German. In *Naturally! Linguistic studies in honour of Wolfgang Ulric Dressler*, eds. Chr. Schaner-Wolles, J. Rennison and F. Neubarth. Torino: Rosenberg & Sellier.
- Van Riemsdijk, Henk, and Edwin Williams. 1981. NP-structure. *Linguistic Review* 171-217.
- Van Riemsdijk, Henk, and Edwin Williams. 1986. *Introduction to the theory of grammar*. Cambridge, Mass.: MIT Press.
- Van Riemsdijk, Henk, and Frans Zwarts. 1997. Left dislocation in Dutch and the status of copying rules [originally written in 1974]. In *Materials on left dislocation*, eds. Elena Anagnostopoulou, Henk van Riemsdijk and Frans Zwarts, 13-54. Amsterdam/Philadelphia: John Benjamins.
- Van Voorst, Jan. 1988. *Event structure*. Amsterdam/Philadelphia: John Benjamins.
- Vanden Wyngaerd, Guido. 1988. Raising-to-object in English and Dutch. *Dutch Working Papers in English Language and Linguistics* 14.
- Vanden Wyngaerd, Guido. 1989. Object shift as an A-movement rule. In *MIT Working Papers in Linguistics*, 256-271. Cambridge, MA: MIT.
- Vanden Wyngaerd, Guido. 1994. *PRO-legomena. Distribution and Reference of infinitival subjects*. Berlin/New York: Mouton de Gruyter.
- Vanden Wyngaerd, Guido. 2009. Reactie op Broekhuis. *Nederlandse Taalkunde* 14:221-224.

- Vanden Wyngaerd, Guido. 2011. Extrapositie als coordinatie: reactie op De Vries. *Nederlandse Taalkunde* 16:296-300.
- Vandeweghe, Willy. 2007. *Grammatica van de Nederlandse zin*. Antwerpen/Apeldoorn: Garant.
- Vandeweghe, Willy. 2011. Het voorzetselvoorwerp en de hiërarchie der objecten. *Nederlandse Taalkunde* 16:88-101.
- Vandeweghe, Willy, and Timothy Colleman. 2011. Drie-argumentstructuurconstructies met een voorzetselobject. *Verlagen & Mededelingen van de Koninklijke Academie voor Nederlandse Taal- en Letterkunde* 121:205-228.
- Vandeweghe, Willy, and Magda Devos. 2003. Relatieve subtypen bij voorzetselobjecten. *Leuvense Bijdragen* 92:103-114.
- Vat, Jan. 1997. Left Dislocation, connectedness and reconstruction [written in 1980]. In *Materials on Left Dislocation*, eds. Elena Anagnostopoulou, Henk Van Riemsdijk and Frans Zwart, 67-92. Amsterdam/Philadelphia.
- Veld, Joop. 1993. *Postverbal constituents in Dutch and Turkish*, University of Amsterdam: PhD thesis.
- Vendler, Zeno. 1957. Verbs and times. *The Philosophical Review* 56:143-160. Reprinted in Zeno Vendler: *Linguistics in philosophy*. Ithaca/New York: Cornell University Press.
- Vergnaud, Jean-Roger 1974. *French relative clauses*, MIT: PhD thesis.
- Vergnaud, Jean-Roger, and Maria Louisa Zubizarreta. 1992. The definite determiner and the inalienable constructions in French and English. *Linguistic Inquiry* 23:592-652.
- Verhagen, Arie. 1979. Fokusbepalingen en grammaticale theorie. *Spektator* 8:372-402.
- Verhagen, Arie. 1986. *Linguistic theory and the function of word order in Dutch. A study on interpretive aspects of the order of adverbials and noun phrases*. Dordrecht: Foris Publications.
- Verhagen, Arie. 2005. *Constructions of intersubjectivity: discourse, syntax, and cognition*. Oxford/New York: Oxford University Press.
- Verkuyl, Henk. 1972. *On the compositional nature of the aspects*. Dordrecht: Reidel.
- Verkuyl, Henk. 1977. Het performatieve van. *Spektator* 6:481-483.
- Verkuyl, Henk. 1993. *A theory of aspectuality. The interaction between temporal and atemporal structure*. Cambridge: Cambridge University Press.
- Verkuyl, Henk. 2005. Aspectual composition: surveying the ingredients. In *Perspectives on aspect*, eds. Henk J. Verkuyl, Henriëtte de Swart and Angeliek van Hout, 19-39. Dordrecht: Springer.
- Verkuyl, Henk. 2008. *Binary tense*. Stanford: CSLI Publications.
- Verrips, Maaïke. 1996. *Potatoes must peel. The acquisition of the Dutch passive*, University of Amsterdam: PhD thesis.
- Verstraete, Jean-Christophe, Sarah D'Hertefelt, and An Van Linden. 2012. A typology of complement insubordination in Dutch. *Studies in Language* 36:123-153.
- Vikner, Sten. 1985. Reichenbach revisited: one, two, or three temporal relations. *Acta Linguistica Hafniensia* 19:81-98.
- Vikner, Sten. 1994. Scandinavian object shift and West Germanic scrambling. In *Studies on Scrambling. Movement and non-movement approaches to free word-Order phenomena*, eds. Norbert Corver and Henk van Riemsdijk, 487-517. Berlin/New York: Mouton de Gruyter.

- Vikner, Sten. 2005. Immobile complex verbs in Germanic. *The Journal of Comparative Germanic Linguistics* 8:83-115.
- Villalba, Xavier. 2008. Exclamatives: a thematic guide with many questions and few answers. *Catalan Journal of Linguistics* 7:9-40.
- Visser, Janneke. 1996. Object drop in Dutch imperatives. In *Linguistics in the Netherlands 1996*, eds. Crit Cremers and Marcel Den Dikken, 257-268. Amsterdam/Philadelphia: Benjamins.
- Vliegen, Maurice. 2006. The relation between lexical and epistemic readings: The equivalents of *promise* and *threaten* in Dutch and German. *Belgian Journal of Linguistics* 20 [Topics in subjectification and modalization, edited by Bert Cornillie & Nicole Delbecque]:73-95.
- Vliegen, Maurice. 2010. Lexikalische Evidentialität: das niederländische *blijken*. Ein evidenter Fall der Grammatikalisierung. In *Grammatik Praxis Geschichte*, eds. Abraham ten Cate, Reinhard Rapp, Jurg Strässler, Maurice Vliegen and Heinrich Weber, 209-216. Tübingen: Narr.
- Vliegen, Maurice. 2011. Evidentiality. Dutch *seem* and *appear* verbs: *blijken*, *lijken*, *schijnen*. In *Linguistics in the Netherlands 2011*, eds. Rick Nouwen and Marion Elenbaas, 125-137. Amsterdam/Philadelphia: John Benjamins.
- Vliegen, Maurice. to appear. Das niederländische *blijken* samt seinen lexikalischen Pendanten im Deutschen. Ein kontrastives Problem. In *Akten des 45. Linguistischen Kolloquiums. 16. bis 18. September 2010* ed. Josef Tóth. Hungary: University of Veszprém.
- Vos, Riet. 1994. *Eurotra grammar. Wh-questions: a comparative study of Dutch, English, Portuguese and Spanish*. Alessandria: Edizioni del'Orso.
- Voskuyl, Jan. 1996. *Comparative morphology. Verb taxonomy in Indonesian, Tagalog and Dutch*, University of Leiden: PhD thesis.
- Webelhuth, Gert. 1989. *Syntactic saturation phenomena and the modern Germanic languages*, University of Massachusetts: PhD thesis.
- Webelhuth, Gert. 1992. *Principles and parameters of syntactic saturation*. New York: Oxford University Press.
- Weerman, Fred. 1989. *The V2 conspiracy. A synchronic and a diachronic analysis of verbal positions in Germanic languages*. Dordrecht/Providence: Foris Publications.
- Wilder, Chris. 1995. Rightward movement as leftward deletion. In *Extraction and extraposition in German*, eds. Uli Lutz and Jürgen Pafel, 229-258. Amsterdam: John Benjamins.
- Williams, Edwin. 1980. Predication. *Linguistic Inquiry* 11:203-238.
- Williams, Edwin. 1981. Argument structure and morphology. *The Linguistic Review* 1:81-114.
- Williams, Edwin. 1981. On the notions 'lexically related' and 'head of a word'. *Linguistic Inquiry* 12:254-274.
- Williams, Edwin. 2003. *Representation theory*. Cambridge, MA/London: MIT Press.
- Wolf, Henk. 2003. Imperatieven in de verleden tijd. *Taal en Tongval* 168-187.
- Wurmbrand, Susanne. 2001. *Infinitives. Restructuring and clause structure*. Berlin/New York: Mouton de Gruyter.

- Wurmbrand, Susanne. 2006. Verb clusters, verb raising and restructuring. In *The Blackwell companion to syntax, Volume V*, eds. Martin Everaert and Henk van Riemsdijk, 229-343. Malden, Ma/Oxford: Blackwell Publishing.
- Zaenen, Annie. 1997. Contrastive dislocation in Dutch and Icelandic. In *Materials on left dislocation*, eds. Elena Anagnostopoulou, Henk van Riemsdijk and Frans Zwart, 119-148. Amsterdam/Philadelphia.
- Zanuttini, Raffaella, and Paul Portner. 2003. Exclamative clauses: at the syntax-semantic interface. *Language* 79:39-81.
- Zubizarreta, María Luisa. 2010. The syntax and prosody of focus: the Bantu-Italian connection. *Iberia: An International Journal of Theoretical Linguistics* 2:131-168. <http://www.siff.us.es/iberia/index.php/ij/article/view/21/18>.
- Zwaan, F.L. 1972. Het voorzetselvoorwerp. *Levende Talen*:347-350.
- Zwart, Jan-Wouter. 1992. Dutch expletives and small clause predicate raising. In *North East Linguistic Society 22*, ed. K. Broderick, 477-491.
- Zwart, Jan-Wouter. 1993. *Dutch syntax. A minimalist approach*, University of Groningen: PhD thesis.
- Zwart, Jan-Wouter. 1996. Clitics, scrambling, and head movement in Dutch. In *Approaching second. Second position clitics and related phenomena*, eds. Aaron L. Halpern and Arnold M. Zwicky, 579-611. Stanford: CSLI.
- Zwart, Jan-Wouter. 1997. *Morphosyntax of verb movement. A minimalist approach to the syntax of Dutch*. Dordrecht: Kluwer Academic Publishers.
- Zwart, Jan-Wouter. 2001. Syntactic and phonological verb movement. *Syntax* 4:34-62.
- Zwart, Jan-Wouter. 2011. *The syntax of Dutch*. Cambridge: Cambridge University Press.
- Zwart, Jan-Wouter, and Eric Hoekstra. 1997. Weer functionele projecties. *Nederlandse Taalkunde* 2:121-132.

*Syntax of Dutch* will include the following volumes:

Nouns and Noun Phrases (volume 1): Hans Broekhuis & Evelien Keizer	[appeared in 2012]
Nouns and Noun Phrases (volume 2): Hans Broekhuis & Marcel den Dikken	[appeared in 2012]
Adjectives and Adjective Phrase Hans Broekhuis	[appeared in 2013]
Adpositions and Adpositional Phrases Hans Broekhuis	[appeared in 2013]
Verbs and Verb Phrases (volume 1) Hans Broekhuis, Norbert Corver & Riet Vos	[appeared in 2015]
Verbs and Verb Phrases (volume 2) Hans Broekhuis & Norbert Corver	[appeared in 2015]
Verbs and Verb Phrases (volume 3) Hans Broekhuis & Norbert Corver	[this volume]
Miscellaneous Topics Hans Broekhuis et al.	[in preparation]

## Comprehensive Grammar Resources – the series

With the rapid development of linguistic theory, the art of grammar writing has changed. Modern research on grammatical structures has tended to uncover many constructions, many in depth properties, many insights that are generally not found in the type of grammar books that are used in schools and in fields related to linguistics. The new factual and analytical body of knowledge that is being built up for many languages is, unfortunately, often buried in articles and books that concentrate on theoretical issues and are, therefore, not available in a systematized way. The *Comprehensive Grammar Resources* (CGR) series intends to make up for this lacuna by publishing extensive grammars that are solidly based on recent theoretical and empirical advances. They intend to present the facts as completely as possible and in a way that will “speak” to modern linguists but will also and increasingly become a new type of grammatical resource for the semi- and non-specialist.

Such grammar works are, of necessity, quite voluminous. And compiling them is a huge task. Furthermore, no grammar can ever be complete. Instead new subdomains can always come under scientific scrutiny and lead to additional volumes. We therefore intend to build up these grammars incrementally, volume by volume.

The *Syntax of Dutch* already resulted in 7 volumes covering the noun phrase, the prepositional phrase, the adjective phrase, and the verb phrase, but other projects are also under way. In Hungary, a research group is working on a grammar of Hungarian. In Beijing efforts are being undertaken to set up a project to produce a Grammar of Mandarin, and plans for other languages are also being drawn up.

In view of the encyclopaedic nature of grammars, and in view of the size of the works, adequate search facilities must be provided in the form of good indices and extensive cross-referencing. Furthermore, frequent updating of such resources is imperative. The best way to achieve these goals is by making the grammar resources available in electronic format on a dedicated platform. Following current trends, the works will therefore appear in dual mode: as open access objects freely perusable by anyone interested, and as hard copy volumes to cater to those who cherish holding a real book in their hands. The scientific quality of these grammar resources will be jointly guaranteed by the series editors Henk van Riemsdijk and István Kenesei and the publishing house Amsterdam University Press.